



AIR POWERED CLIPPER & LABEL PRINTER

ITEM NUMBER _____

JOB NAME / NUMBER _____



AIR POWERED CLIPPER

Cleveland Standard Features

- Horizontal Clipper with automatic Clip feeding mechanism
- Seals Casings and trims ends in one quick Operation
- Provides an Air and Water tight Seal
- Unique closing devise assists in gathering Casing Neck
- Capable of clipping up to 40 Casings per Minute
- Adjustable Clip Crimping Control
- Safety shut-off Valve
- Air pressure Gauge

MODEL: Z-4100HL

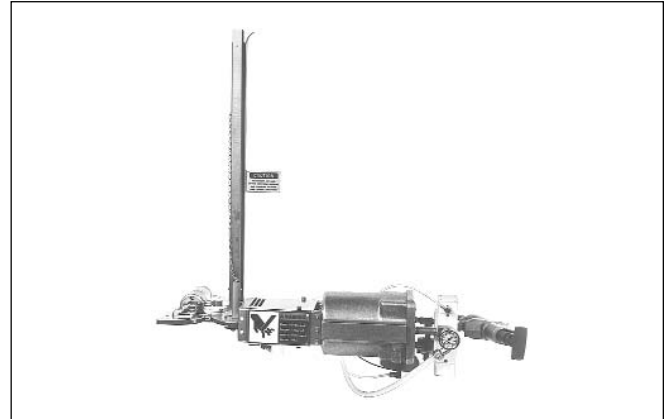

Short Form Specifications

Shall be Cleveland Model Z-4100HL, Air powered Casing Clipper with Automatic Clip feeding mechanism; adjustable Clip crimping Control; Air pressure Gauge and Safety shut-off Valve.

LABEL PRINTER

Cleveland Standard Features

- Manual Type Label Maker for use with Tyvek Label Tape
- Re-inkable, quick change Ink Cartridge
- Baselock Marking Wheel with knurled Steel Drive Tracks
- For maximum Print Height of 2"
- Basic Letter Set and waterproof Ink
- Re-inking Kit

MODEL: T-105



Short Form Specifications

Shall be Cleveland Model T-105, manual Tape, Label Maker, Baselock Marking Wheel, Ink Cartridge, Re-inking Kit and Basic Letter Set.

Options & Accessories

- Tyvek Label Tape (2 1/2" wide)
- Different types of Lettering
- Mounting Bracket for Food Pump

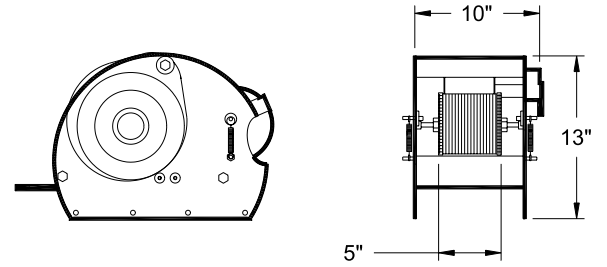
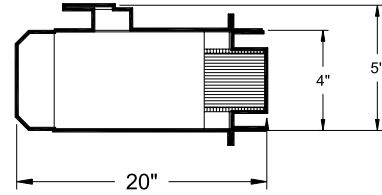
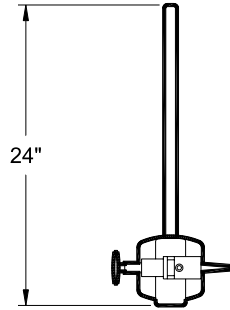
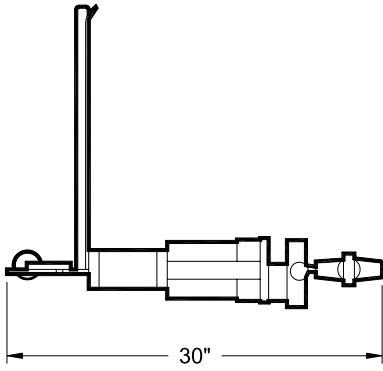
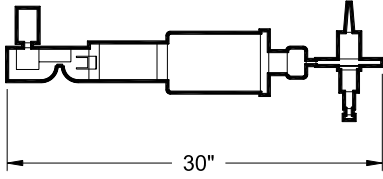

Z-4100HL
CASING CLIPPER

T-105
LABEL PRINTER

CASING CLIPPER

MODEL	AIR	ELECTRICAL
Z-4100HL	10 CFM, 90 to 110 PSI	NONE

LABEL PRINTER

MODEL	DESCRIPTION	UTILITIES
T-105	LABEL PRINTER	NONE



TIPPER TIE®

A **DOVER** INDUSTRIES COMPANY

P.O. BOX 866 LUFKIN ROAD
APEX, N.C. USA 27502-0866
(919) 362-8811 or 1-800-331-2905
FAX: (919) 362-8667

Clipper Manual
Models Z4100HL & HR

Manual No. 80-1255
Revision No. 00
(03/02/2000)

Tipper Tie Models Z4100HL & HR

Table of Contents

Chapter 1: Machine Description and Specifications	
1.1 Description	5
1.2 Applications	5
1.3 Machine specifications	6
Chapter 2: Safety Instructions	
2.1 International Safety signs	7-8
2.2 Safety Instructions	9-10
2.3 Danger Areas	11
2.4 Sound levels	12
Chapter 3: Delivery and Inspection	
3.1 Delivery and inspection	13
3.2 Unpacking equipment	13
Chapter 4: Air Connections and Lubrication	
4.1 Installation of Main Air Supply	14
4.2 Filter / Regulator / Lubricator	14
4.3 Air regulator Assembly	15
4.4 Lubricator Adjustment	16
4.5 Regulator Adjustment	17
Chapter 5: Operating instructions	
5.1 Preparation	18
5.2 Operating machine	18
5.3 Crimp control	19
5.4 Punch Assembly Procedure	20
5.5 Clipper cycle	21
Chapter 6: Cleaning Procedure	
6.1 U.S. Department of Agriculture Guidelines	22-23
6.2 Cleaning Procedure	24
Chapter 7: Maintenance	
7.1 General maintenance Checklist	25
7.2 Lubricator Maintenance	26
7.3 Filter / Regulator Maintenance	26

Chapter 8 Trouble Shooting Guide	27
Chapter 9: Spare Parts List	
9.1 Recommended Spare Parts	28
9.2 Loose Parts List	28
Chapter 10:Assembly drawings	29

Chapter 1: Machine Description and Specifications

1.1 Description

The Tipper Tie Clipper, Models Z4100HL & HR are horizontally mounted clippers designed apply a secure seal on a variety of packaging materials. For each clipper cycle, the machines will do the following:

- * *Gather the neck of the bag*
- * *Apply a secure leak proof seal*
- * *Trim excess bag tail from product*

The clippers are designed to operate with all Tipper Tie Z400 series stick clips. Clip size is determined and selected on the basis of product or closure size. A Tipper Tie representative will gladly assist in determining the correct clip for the given application.

1.2 Applications

The Z4100HL & HR clippers are designed to provide one-step closing for a variety of food products, such as beef, poultry, cheeses, or a wide assortment of non-food products.

1.3 Machine Specifications

- Air Consumption:** 4 cubic feet per cycle at 80 PSI, (113,3 Liters at 5,5 Bar)
- Air Requirements:** 80-100 PSI, (5,5 - 6,9 Bar)
- Clip size:** Z400 series stick clips
- Machine weight:** 35 lbs. (15,9 Kg.)
- Shipping weight:** 42 lbs. (19,0 Kg.)

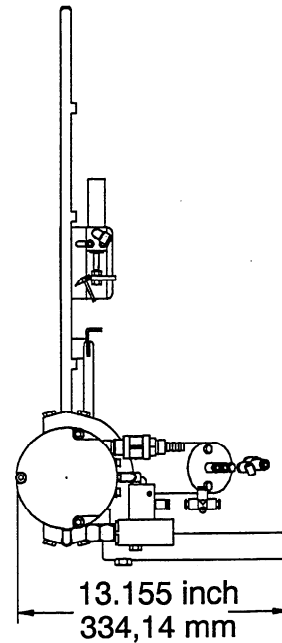
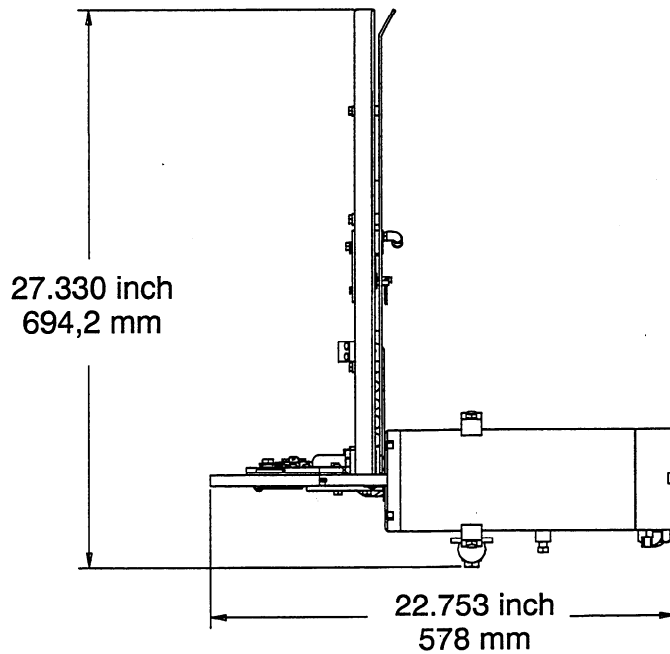
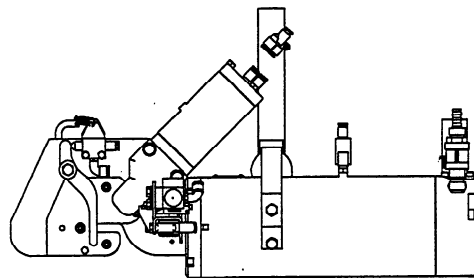

Chapter 2: Safety Instructions

2.1 International Safety Signs

International safety signs are used to communicate hazard information used with appropriate machine functions.

- The yellow triangle signs warn of existing hazardous conditions.
- The blue circular signs define mandatory actions required.

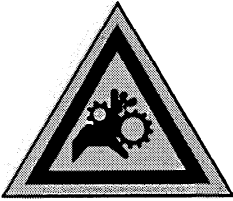

WARNING: DANGER OF CRUSHING

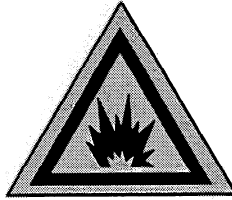

WARNING: EXPLOSIVE ATMOSPHERE

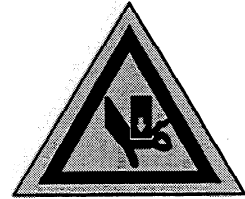

WARNING: KEEP HANDS AWAY FROM PINCH AREA

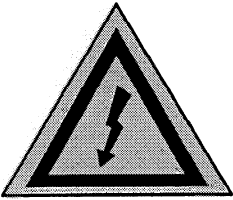

WARNING: DANGEROUS ELECTRICAL CURRENT

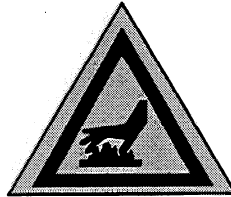

WARNING: HOT SURFACE



WARNING: KEEP HANDS AWAY FROM KNIFE AREA

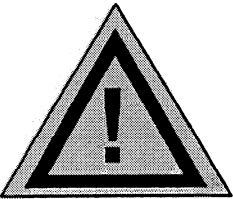

WARNING:

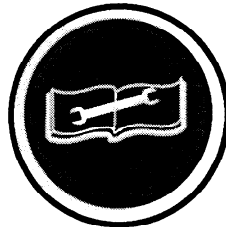

READ MANUAL BEFORE SERVICING

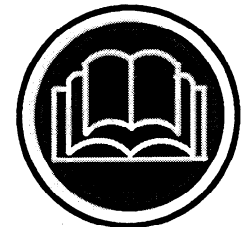

READ MANUAL BEFORE OPERATING



ELECTRICAL LOCKOUT REQUIRED

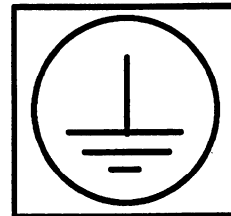

PROTECTIVE EARTH GROUND

2.1 International Safety Signs continued:



WARNING:

When using this machine, all operating instructions, safety instructions and precautions must be followed and strictly adhered!

Do not attempt to install, setup or operate this machine before you have read and understood this manual and any accompanying supplier's manuals.

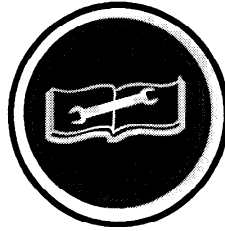
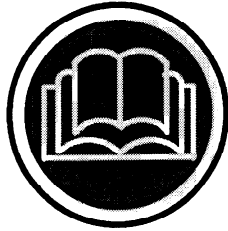

Follow all warnings and safety instructions in this manual. Failure to comply with safety instructions could result in serious injury.

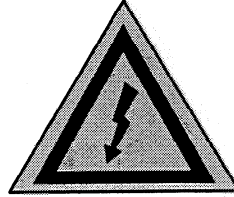
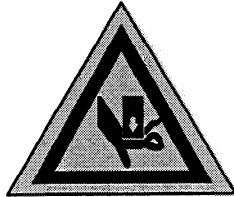

2.2 Safety Instructions

With the use of this machine, the following safety precautions must be obeyed:

- Before installing and first operating the machine, this manual must be read and understood. Follow all operating and safety instructions and exercise extreme care.
- This machine must be installed securely, and permanently attached to a solid surface before starting and operating.
- This machine must be operated only by trained personnel. Training must be repeated at regular intervals.
- Safety devices must be checked each day to ensure proper operation. Safety features should be examined once each year by experts.
- All guards, protective covers and shields must be in place before operating the machine. Do not modify, remove, disable or bypass the guards. Operating this machine with guards, covers and shields removed could result in serious injury. **Never operate this machine without safety devices.**
- **The maximum working pressure for this machine is 100 psi, (6,9 bars)**
Air pressure greater than this could cause an explosive rupture in any of the air lines or pneumatic components. Failure to adhere to this caution could result in personal injury or damage to the machine.
- Keep hands and fingers clear of the punch, die and knife areas at all times. Never touch these areas while the machine is in operation. Do not allow fingers, hands, jewelry or clothes around moving parts during operation of this machine.

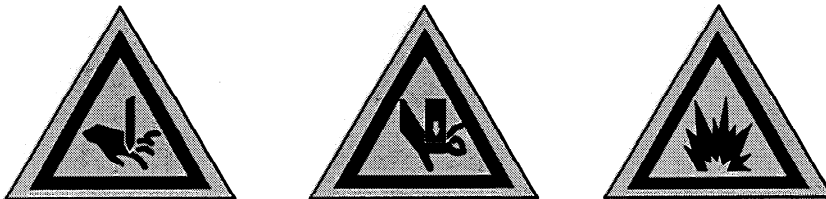

2.2 Safety Instructions continued:

- Immediately report any malfunction to the person in charge
- Stop machine to correct malfunctions.
- Disconnect air supply prior to servicing or moving the machine. The main air supply line must be disconnected from the machine before performing any service operation or maintenance.
- When this machine is not in operation, the air supply must be disconnected at the plant / regulator junction or at the quick disconnect on the machine. Failure to disconnect the air supply from this machine creates serious risk of injury. To prevent unauthorized personnel from operating this machine, rotate the red emergency stop valve 1/4 turn clockwise. Attach a padlock through the holes.
- When moving the machine, keep hands and fingers clear of punch, die and knife areas.
- Use only original spare parts and accessories.
- If the machine is sold, the manual must be supplied to the new owner.

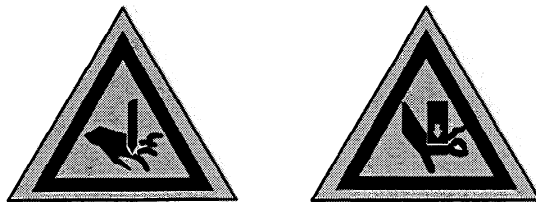

2.3 Danger areas

Warning:
Keep hands and fingers clear of die,
punch, and knife areas.

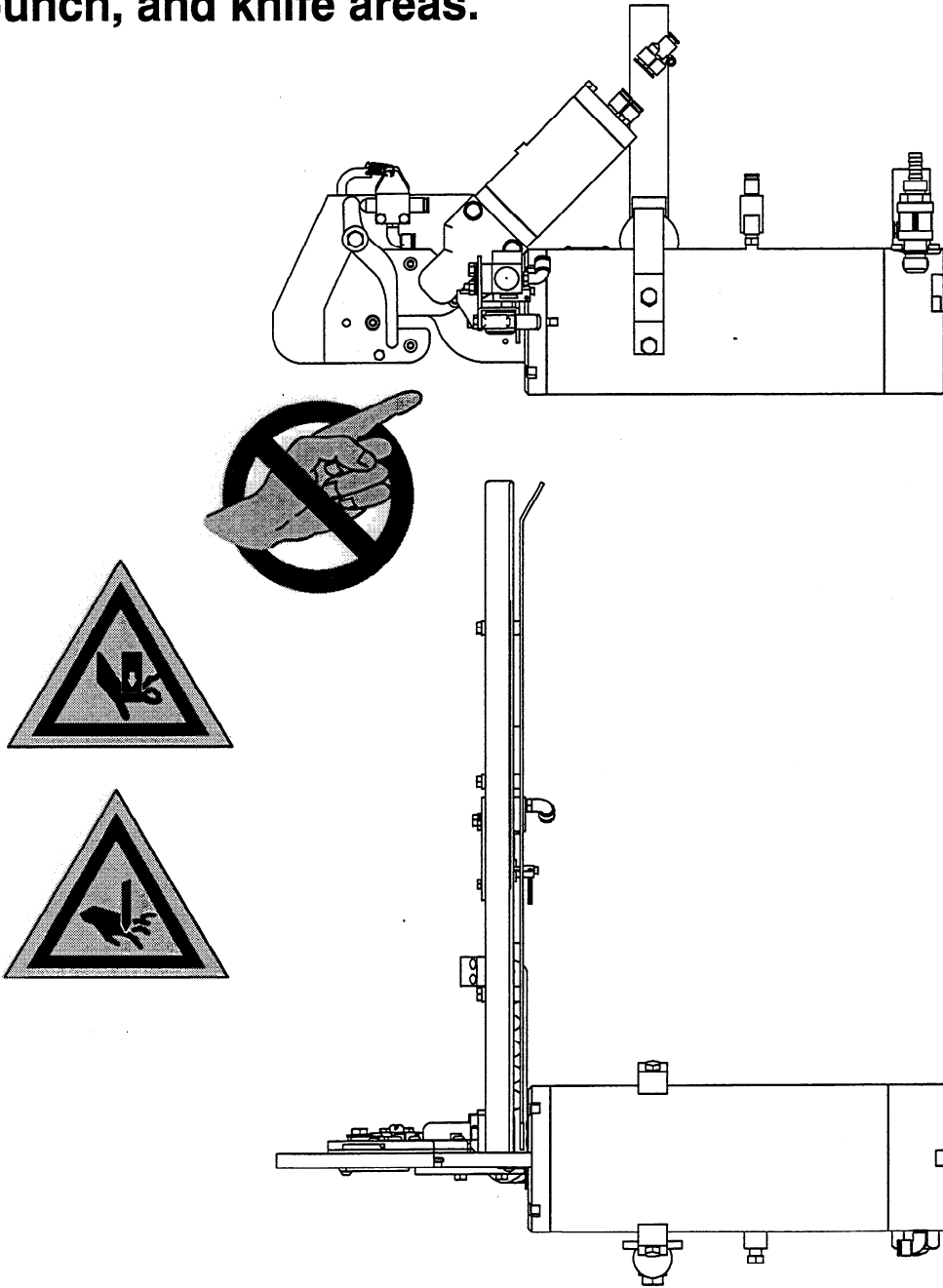

Chapter 2 Continued:

2.4 Sound levels

The sound and noise level tests were conducted under the European Norm Number 31201, Noise Emitted by Machinery & Equipment Standards for Emission of Both Peak & Continuous Sound Levels at a Work Station.

The tests were conducted for both continuous and peak noise levels. The following data are a result of the test:

Continuous sound power level:

“A” Weighted scale

1000 Hertz Frequency Range

Continuous Sound Levels were recorded at dB.

The standard indicated the 8 hours exposure level shall not exceed 85dB without hearing protection.

Peak instantaneous sound pressure value:

“C” Weighted scale

1000 Hertz Frequency Range

Peak instantaneous Sound Pressure Values were recorded at dB.

The standard indicates the Peak Instantaneous Sound Pressure Level Shall not exceed 130dB on the “C” weighted scale without hearing protection.

The sound tests were conducted as specified in the standard, from a height of 1.6 meters from the floor and 1/2 meter from the machine. This test location simulated the distance an operator would be standing in relation to the machine and at the hearing height of an average person.

Chapter 3: Delivery and Inspection

3.1 Delivery

Upon delivery, inspect the shipping container and equipment for damages due to shipping and handling. If damage is found or suspected, contact the shipping agent immediately. In order that the carrier may have an opportunity to inspect goods and thereby properly verify claims, any loss or damage discovered after delivery should be reported to the agent of the delivering line immediately or within 15 days after receipt of goods.

In many instances, the original container is not opened and the contents not examined before reshipment to final destination. Therefore, under (SUBPART C: CLAIMS FOR LOSS OR DAMAGE: SECTION 1226.200 NATIONAL MOTOR FREIGHT CLASSIFICATION), 9 months are allowed for filing claims for loss or damages.

The shipping agent or carrier will help you in processing your claim. Remember to report all suspected damages immediately. If additional assistance is required, TIPPER TIE will gladly help in settling your claim. However, first contact the carrier or his agent involved.

WITH ALL CORRESPONDENCE, INCLUDE THE FOLLOWING:

- * Original bill of lading or copy thereof. *
- * Vendor invoice, or certified copy, when claim is based on weight or valuation of shipment has been improperly described.
- * Catalog pages or product information.
- * Original packing slip or receiving reports.
 - * or copy of electronic bill of lading manifest.

3.2 Unpacking Equipment

For ease of shipping, partial disassembly of the machine sometimes is necessary. Check the shipping list and loose parts list to ensure that all items have been received. Do not discard packing materials until machine is assembled and operation. notify **Tipper Tie** immediately if any component is missing or if additional assistance is required.

Refer to the installation and operating instructions before starting to operate the equipment. Add all required oils and fluids, and make all machine adjustments as instructed before starting machine. Failure to do so may result in equipment damage or personal injury, and voids product warranty.

Chapter 4: Air Connections and Lubrication

4.1 Installation of Main Air Supply

Recommended clipper working pressure setting is 80psi (5,5 bar). Before operating, check clipper air line connections as set at factory. If lines have become disconnected, reassemble as shown per pneumatic schematic. Air pressure can be regulated from the air regulator assembly. The air regulator assembly consists of filter, regulator, and oiler. Please note incoming air direction. (plant air flow)

Assemble the factory air supply to the air regulator assembly by means of the quick-disconnect, connector. This quick-disconnect provides a means of removing the air supply for servicing and clean-up. The quick-disconnect must be attached with the check valve half (female), to the supply side of the air circuit.

4.2 Filter / Regulator / Lubricator

The filter must be kept clean to maintain maximum filtering efficiency. Open drain cock, under the filter periodically and drain off any bowl accumulation before it reaches level of lower baffle. A visible coating of dirt or condensate on the filter element surface or an excessive pressure drop is an indication that cleaning is necessary. To clean, turn-off air supply, and depressurize. Loosen locking collar and remove bowl. Clean all parts with denatured alcohol and blow-out the inside with compressed air.

4.4 Filter, Regulator, Lubricator Assembly, (FRL)

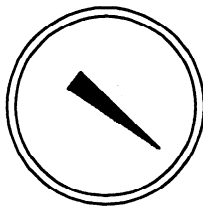
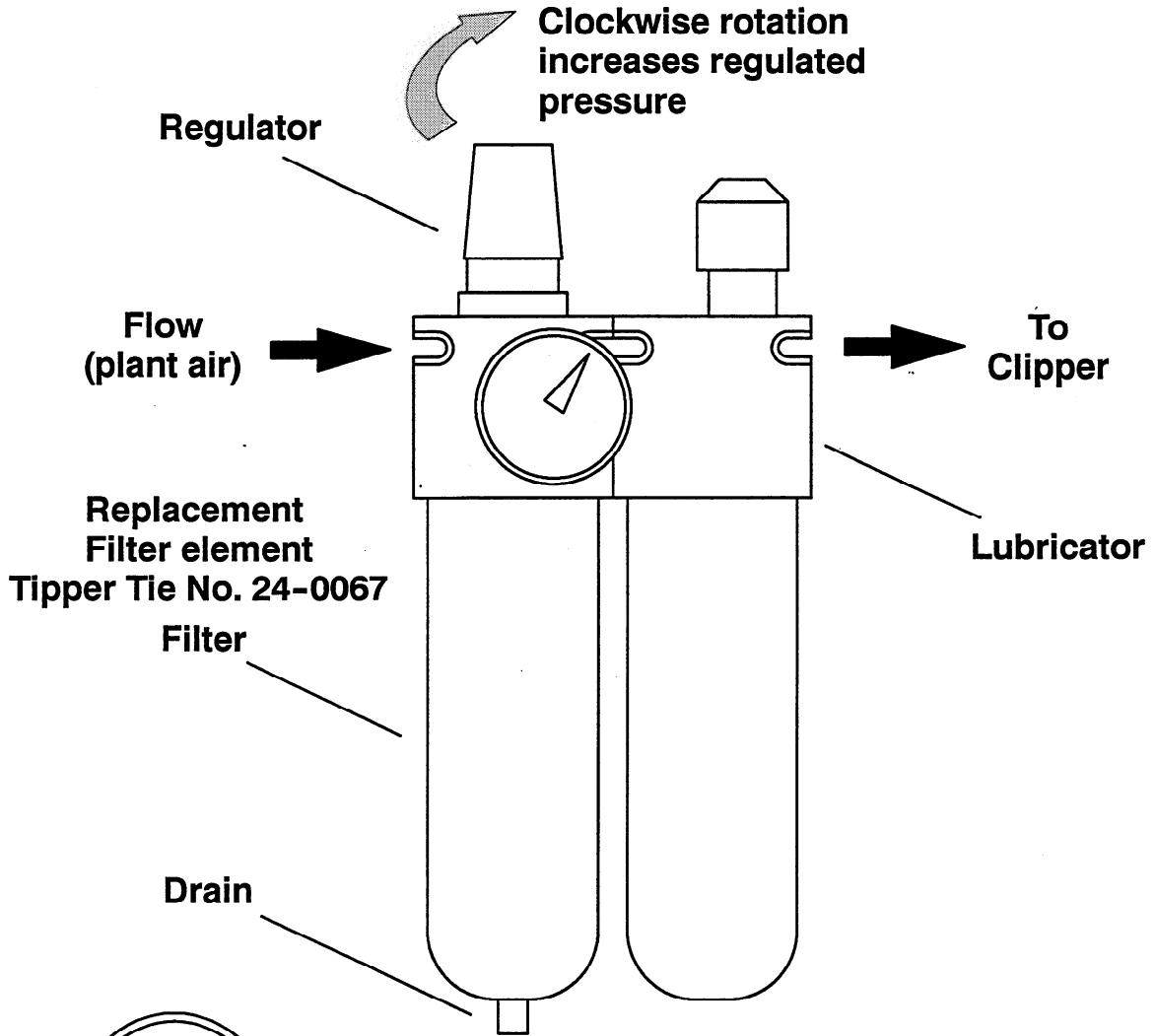

**Recommended Pressure Setting:
80 psi, (5,5 bar)**



**Warning:
Do not set air pressure
above 100 psi, (6,9 bar)**

4.4 Lubricator Adjustment

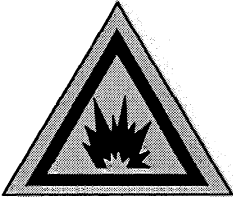

Do not attempt to add oil to the lubricator while under pressure. Disconnect the air pressure supply and purge pressure from the system before filling with lubrication fluids.

The lubricator cannot be filled while under pressure.

LUBRICATION:

For average operating conditions, the use of SAE #10 (SUV > 150-200 SEC @100 degrees F) oil is recommended. Other lubrications may be used if not heavier than SAE #40 (SUV 800 SEC @ 100 degrees F).

FILLING:

Shut down and depressurize before refilling lubricator. Slowly remove the fill plug and fill to 1/4 inch to the top of the bowl using recommended oil.

ADJUSTMENT:

The adjustment knob is calibrated from "0" to "9". At "0" no oil is delivered, the unit is not lubricating. To adjust, first turn on the air. Turn the knob to start oil flow, observing the drip rate visible through the sight glass. One to two drops per minute is suggested, correct lubrication being a matter of experience and demand. *Counter-clockwise rotation of knob increases oil feed rate.*

To check lubrication, hold a mirror of similar material near the equipment exhaust. A heavy film discharge indicates over-lubrication. The oil drop rate should be reduced by turning the knob to a lower setting, decreasing oil drop rate.

If no oil drips through the sight glass with the needle valve open, proceed as follows:

- Make certain there is sufficient oil in the bowl.
- Check to determine whether there is air pressure ahead of the lubricator.
- Check the air flow from the lubricator.

If oil still does not drip through the sight glass, an accumulation of dirt in the lubricator is indicated. The lubricator will need to be cleaned.

4.6 Air regulator adjustment

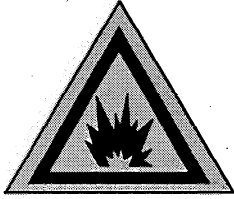

It is recommended that air pressure remain between 80 - 100 PSI (5,5- 6,9 Bar)

Always keep air pressure below 100 PSI (6,9 Bar)

Clockwise turning of the adjusting knob increases the regulated pressure. Erratic regulator operation or loss of regulation is due most often to dirt in the disk area of the regulator, requiring disassembly and cleaning. To clean, turn-off air supply, and depressurize. Remove bottom plug, spring and disc. Clean all parts with denatured alcohol, wipe off seat, and blow-out regulator body with compressed air. Reassemble as a unit. Before tightening plug make sure disk is centered.

Chapter 5: Operating instructions

5.1 Preparation

Before operating check all air connections. If they have become disconnected, reassemble as shown in the pneumatic schematic. Adjust incoming air to the recommended pressure of 80 PSI (5,5 Bar) and check for any air leakage. If leakage is present, correct before continuing. Load clip stick, and push clips down rails and manually reset clip pusher. Check for proper feeding, and for any obstructions at the punch, knife, and die areas.

5.2 Operating the Machine

- Slide the package to be clipped into the slot of the clipper die support. When the package reaches the bottom of the throat, the trigger activates the trigger valve. The clipper goes through its cycle. The trigger valve will reset automatically at the end of the clipping cycle.
- The trigger valve activates the punch cylinder. The punch advances into the die forming a clip onto the product.
- Once the correct pressure is reached, the air pressure continues to the cut-off knife cylinder, extending the knife.
- After the cut-off knife fully extends and cuts off the excess package, start to remove the product. The trigger valve resets, retracting the cut-off knife and clip punch.
- Continue to remove the package out of the clipper by pulling the material away from the bottom of the die support plate.
- System resets, machine is ready for another cycle.

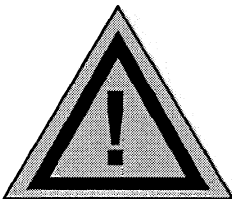

Warning!

If a clip jams in the die area, do not attempt to cycle the machine again until the jam is cleared. Follow all safety procedures! Turn off the air supply, lock-out the emergency stop valve, before attempting to remove the clip or other obstruction from the die area.

5.3 Crimp Control

The pressure sensing valve located on the back of the punch cylinder controls the crimp or tightness of the clip. Turn the adjustment knob clockwise to tighten the clip's crimp (tightness) on the product. To loosen, turn counterclockwise.

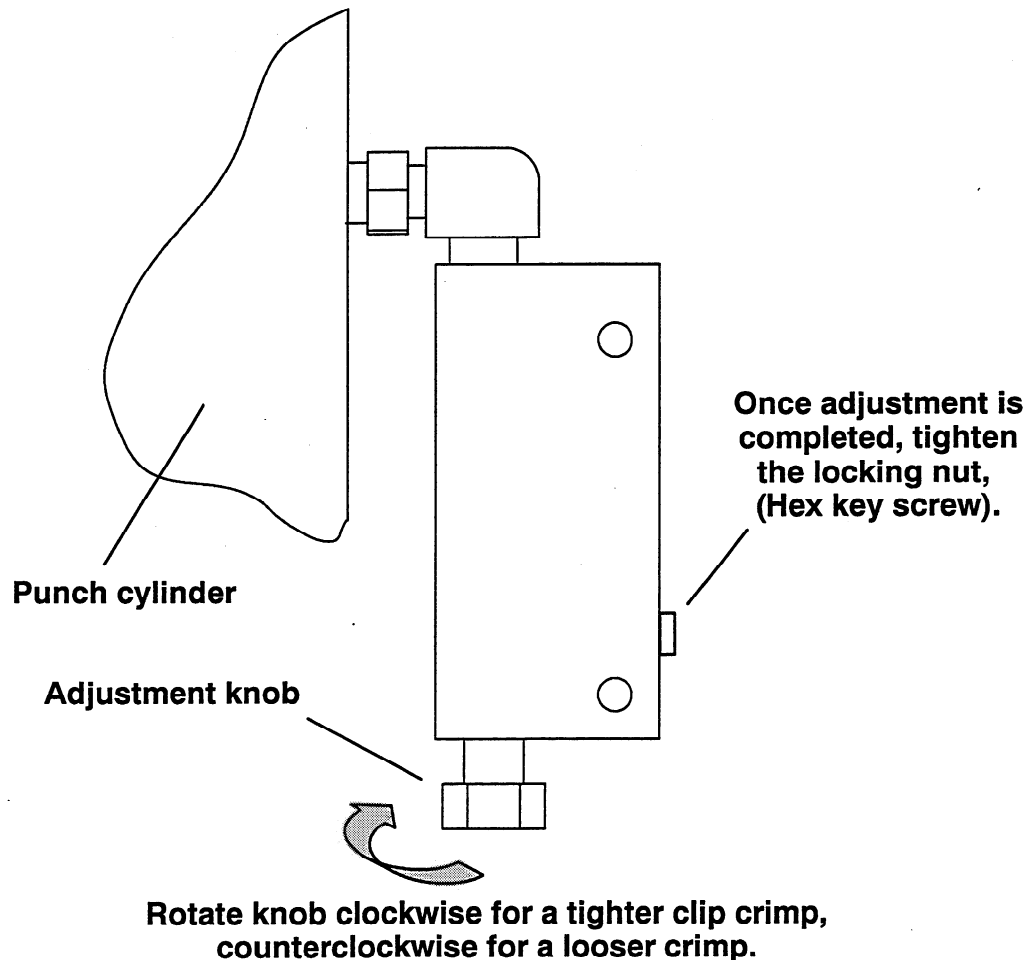

**Pressure sensing valve
on the back of the punch cylinder**

5.4 Punch assembly procedure

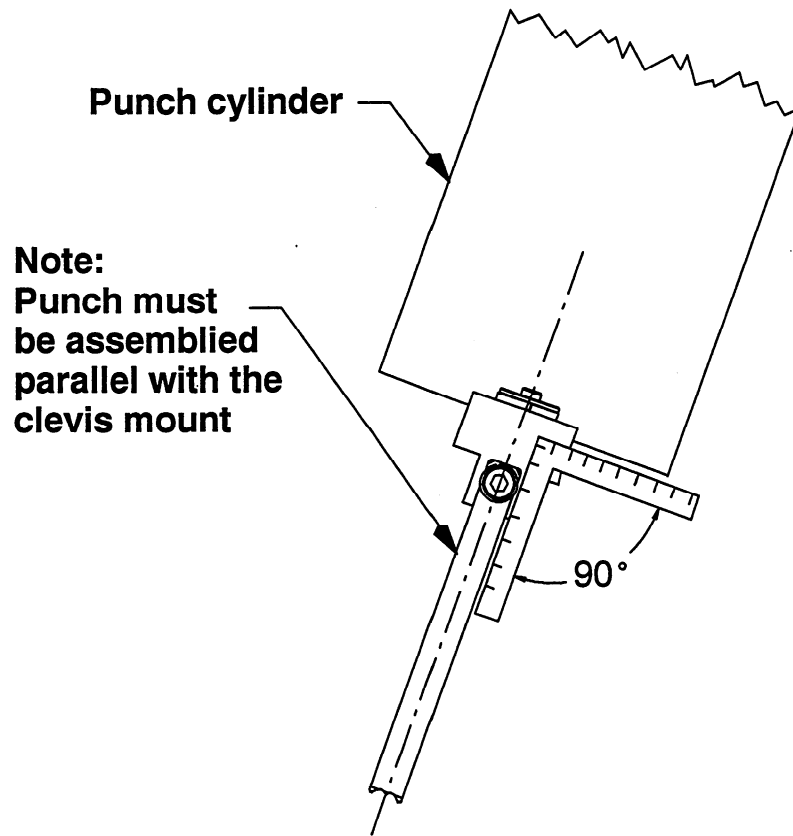

5.5 Clipper Cycle

- A) Push product into slot on the Die plate.
- B) Product activates the punch trigger valve.
- C) Punch assembly starts forward, and a clip is taken from rail. At the end of the stroke, the clip forms onto product in the forming Die.
- D) At end of punch stroke, cut-off knife extends and trims off product tail.
- E) Valve resets system. Knife and punch retract.
- F) Remove product. Machine is ready for another cycle.

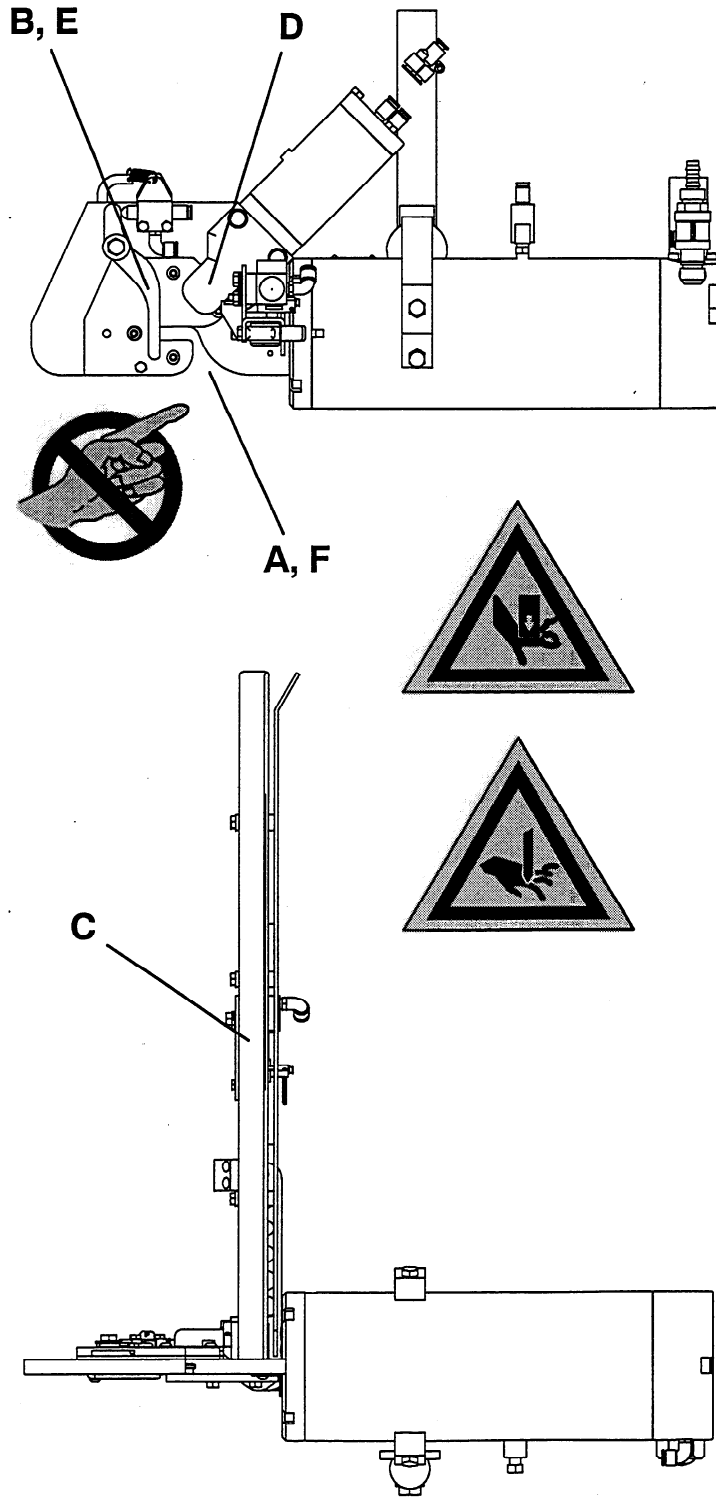

Chapter 6: Cleaning Procedure

6.1 U.S. Department of Agriculture Guidelines

**APPROVED CLEANING COMPOUNDS:
U.S. DEPARTMENT OF AGRICULTURE
FOOD SAFETY AND INSPECTION SERVICE
(REFERENCE AGRICULTURE HANDBOOK NO. 562)**

This publication is intended to assist in applying approved cleaning methods under the USDA meat and inspection program. Cleaning materials used must be in compliance with the USDA. Compliance with the requirements set forth in the publication does not, in itself constitute authorization. Users must submit application with the USDA for consideration of suitability of preparations and their safety for use as directed.

Submit requests for such evaluation to :

Compounds Evaluation Unit, CPS
Product Safety Branch
Food Ingredient Assessment Division, Science, FSQS
U.S. Department of Agriculture
Building 396, Room 300, Barc-East
Beltsville, MD 20705
Tel (301) 344-2566

**U.S. Department of Agriculture Food Safety and Inspection Service
Handbook No. 562 Part 5, Section 5.1 Cleaning Compound**

(A) GENERAL USE CRITERIA

- (1) Neutral or mildly alkaline preparations consisting of any combination of soaps, detergents, wetting agents, emulsifiers, solubilizers, and common inorganic builders may be used on any surface in and department
- (2) Strongly alkaline preparations (those containing in excess of 20 percent caustic soda or other ingredients with the equivalent causticity thereof) may be used only in soak tanks or with steam or mechanical cleaning devices in any department
- (3) Acidic preparations consisting of mineral acids, organic acids, or acidic salts may be used in any department for the removal of rust, corrosion, scale, or other deposits which are not readily removed by alkaline preparations.

(B) RESTRICTIONS OF USE

- (1) Before using any cleaning preparation, food products and packaging materials must be removed from the room or carefully protected. After using such preparations, all surfaces must be thoroughly rinsed with potable water.
- (2) Preparations having a characteristic odor of fragrance as diluted for use may, in the opinion of the USDA, interfere with sanitary inspection of food contact surfaces may not be used on food contact surfaces. They may be authorized for limited use on floors and walls only.
- (3) Preparations containing abrasive materials such as silica, pumice, etc. may be used on food contact surfaces only if care is taken to remove all odors or residues resulting from their use by thorough rinsing with potable water.
- (4) Boric acid and salts thereof, may be used in such preparations only at concentrations up to 90 percent in association with strong acids, strong alkalis, soaps, or synthetic detergents.

6.2 Cleaning procedure

After use of machine, the clipper must be cleaned to remove all residues (food products) from the throat, punch, knife and die areas, (*food contact zone*). Also check all other machine surfaces and surrounding work station for material residues or contamination. All surfaces must be cleaned using the recommended materials and procedures as outlined by the U.S. Department of Agriculture Food and Inspection Service Handbook No. 562. A copy of Part 5, Section 5.1, Titled: Cleaning Compounds: is included with this manual. Cleaning product approval, in writing is required, as outlined in the copy provided.

Remember, before cleaning the clipper, ensure that the air supply has been disconnected from the clipper, and all lock-out procedures have been followed.

Never attempt to clean the clipper while it is attached to the air supply!

- Turn off factory air and disconnect the air line from the clipper with the "Quick disconnect" attached on the rear of the clipper.
- Remove all guards to expose all surfaces for cleaning.
- Clean all surfaces as outlined by the U.S. Department of Agriculture Handbook.
- After cleaning, (FDA food contact approved) light mineral should be applied to all pivot areas. The internal moving parts are lubricated by the filter / regulator / lubricator.
- After cleaning and lubricating, reassemble all guards and check for safe function. Check for and tighten all loose connections and screws before returning machine to operation. Check for and remove all burrs around die pocket.
- While cleaning the clipper, inspect for worn or damaged components needing replacement. For replacement parts refer to the list of recommended spare parts, and assembly drawing.

Chapter 7: Maintenance

7.1 General Maintenance Checklist

- Check regularly for loose screws.
- Check the oil level in the lubricator regularly
- Check the air filter on a regular basis
- Check the knife for signs of chipping
- Check the end of the punch for burrs
- Check guards for safe function

Check for and tighten all loose connections and screws before returning machine to operation. Check for and remove any burrs around die pockets.

While cleaning the clipper, inspect for worn or damaged components needing replacement. For replacement parts refer to the list or recommended spare parts and assembly drawings.

7.2 Lubricator Maintenance

The oil level in the lubricator must never be allowed to drop below the end of the dip tube. To replenish oil, first shut off the air supply, lock-out the system. Remove the slotted filler plug and fill to oil level mark. Replace and tighten plug.

Normally, the lubricator should require only occasional cleaning, provided clean oil is used, and the air supply is kept clean by the filter system. However, if no oil drips through the sight glass, and the oil supply has been replenished, the lubricator requires cleaning.

Check the following before cleaning the lubricator:

- Make sure there is sufficient oil in the bowl.
- Check to determine whether there is air pressure ahead of the lubricator
- Check the air flow from the lubricator

If each of these areas are functioning properly, continue to clean the lubricator.

7.3 Filter / Regulator / Maintenance

The air filter is equipped with an automatic drain that should be cleaned periodically to maintain maximum filter efficiency. Open drain cock under the filter periodically and drain off any bowl accumulation before it reaches level of the lower baffle. A visible coating of dirt on the filter element surface or an excessive pressure drop in an indication that cleaning is necessary.

To clean the filter, turn off air supply, lock out system, and depressurize. Loosen locking collar and remove bowl. Clean all parts with denatured alcohol and blow out the inside with compressed air.

To clean the regulator, turn off air supply, lock out system, and depressurize. Remove the bottom plug, spring, and disk. Clean all parts with denatured alcohol. Wipe off seat and blow out regulator body with compressed air. Reassemble the filter / regulator unit. Before tightening the plug, make certain the disk is centered.

After cleaning and servicing, the air regulator may need adjusting. Adjust the incoming air to the recommended pressure settings of 80-100 psi, (5,5-6,9 bar). Always keep air pressure below 100 psi, (6,9 bar).

Always check the air muffler for oil build up and blockage. A muffler caked with oil or accumulated contamination will restrict the porting of the used air into the atmosphere, and slow down the machine. Always check the mufflers when servicing the filter / regulator unit, and replace as required.

Chapter 8: Trouble Shooting Guide

Symptoms

Solution

Clipper has no power

- Air connection may be loose. Check all air connections.
- or Regulator may be turned off. Check the regulator unit.
 - or Water may be in the system. Drain and change the filter.

Clipper is slow

- Water may be in the system. Drain the water and change the filter.
- or Muffler may be clogged. Replace the muffler.
 - or Pressure to the clipper is low. Check the pressure setting and increase if necessary.
 - or Air lines are pinched. Replace the air lines.
 - or Cylinder is stuck. First check for pinched air line and check the air pressure. If cylinder is still stuck, disconnect air line and check for broken or worn parts. Replace bad parts or air cylinder.

Punch does not retract

Knife blade housing may be jammed with product residue. Disassemble and clean.

Knife does not cut

Check knife for nicks and sharpen as needed.

Malformed clips

- Punch or die may be damaged. Replace as necessary.
- or Air pressure may be too low or too high. Check air pressure and adjust if necessary.

Clips are loose and seal poorly

- Check crimp control and adjust if needed.
- or Air pressure is too low. Check air pressure and adjust if necessary.
 - or Punch and die may be worn down. Check for wear on punch and die, and replace if needed.

Chapter 9: Spare parts List

When ordering replacement or spare parts, always include the following:

Machine model number and date of purchase:

Identifying part numbers stamped on part:

**Part number or numbers on spare parts list,
or identifying item numbers on assembly drawings:**

9.1 Recommended Spare parts

Item	Part No.	Description	Qty.
1	00-1461	Seal kit, knife cylinder	1
2	00-1462	Seal kit, 4" Air return cylinder	1
3	05-0126	Die, Z400	1
4	11-0116	Knife	1
5	13-0107	Punch, Z400	1
6	17-0128	Spring, Die guard	1
7	17-0131	Torsion spring, pawl	2
8	21-0150	Pressure sensing valve	1
9	21-0308	Trigger valve	1
10	29-0858	M3 x 30mm lg. Soc. Hd. sst screw	2
11	99-1242	M3 Lockwasher	2

**The above items may be ordered by individual part numbers
or they may be ordered as a kit: No. 00-1464**

9.2 Loose Parts List

Item	Part No.	Description	Qty.
1	28-4636	3/8 Air hose Assembly	1
2	80-1255	Z4100HL & HR Operators Manual	1

Chapter 10: Assembly Drawings

Z4100HL	Clipper Model Z4100HL
Z4100HR	Clipper Model Z4100HR
00-1337	4" cylinder air return
00-1338	Knife cylinder
00-1349	Rail Assembly 4100HL
00-1350	Rail assembly 4100HR
63-0165	Pneumatic Schematic
28-4636	3/8 inch Hose Assembly

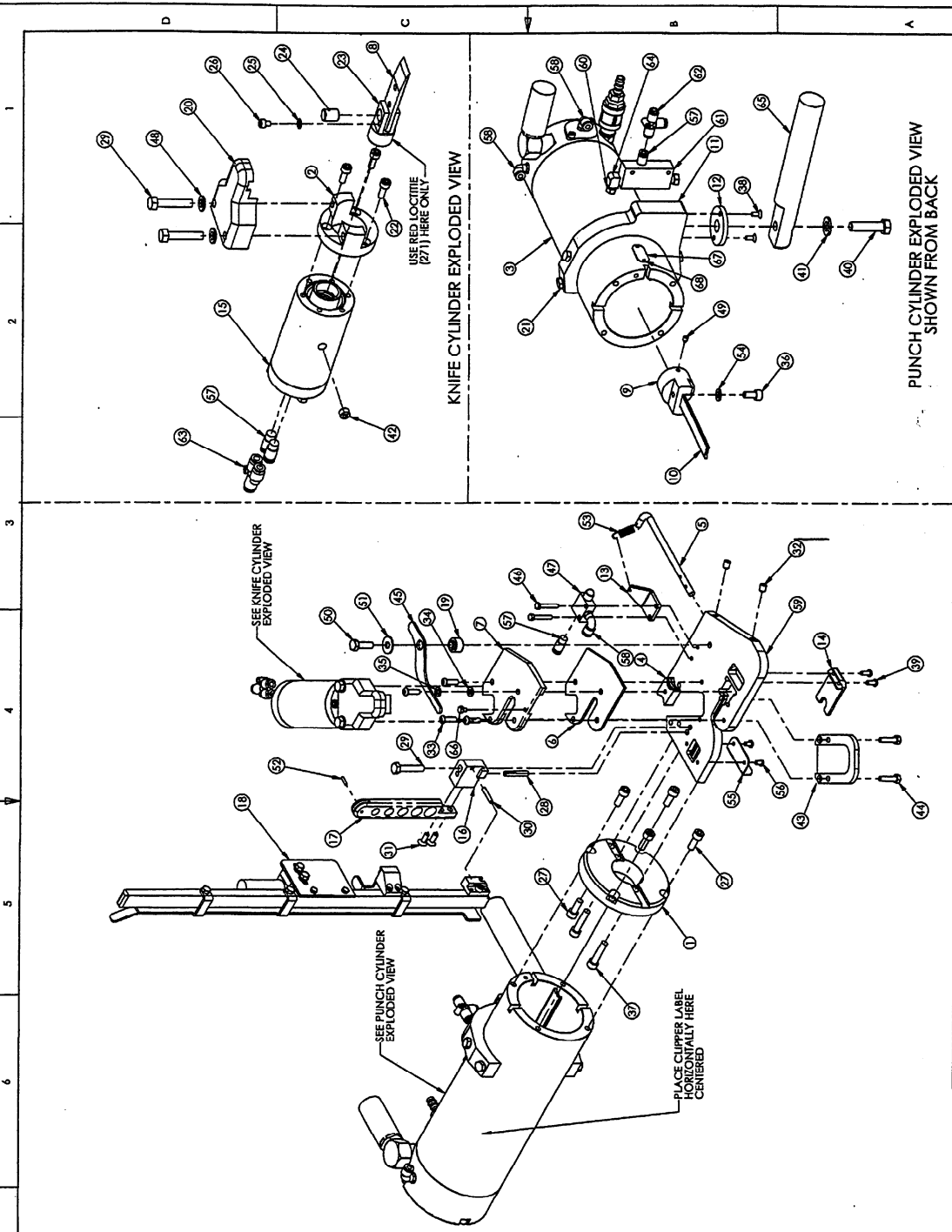

ITEM NO.	QTY.	PART NO.	DESCRIPTION
1		104-0386	PUNCH CYLINDER CAP BOTTOM
2		104-0384	KNIFE CYLINDER HEAD CAP
3		100-1337	4" CYL. AIR RETURN
4		105-0126	DIE-7400 DOUBLE SIDED
5		13-4340	FLAPPER KOD
6		132-1542	KNIFE CYLINDER 74100 SERIES CLIPPER
7		111-0116	KNIFE 74100H
8		199-0613	PUNCH CLEVIS 74100
9		113-0107	PUNCH-74100
10		110-2211	4" CYL. MOUNT - HORIZONTAL
11		110-8167	BALL MOUNTING COVER PLATE
12		132-1537	SPRING MFG. PLATE
13		132-1538	DIE FLAPPER 74100
14		100-1338	KNIFE CYLINDER
15		101-0573	RAIL BLOCK HORIZONTAL R.H.
16		110-2212	RAIL CATCH BLOCK
17		100-1350	RAIL ASSEMBLY - 4100HR
18		116-0491	TRIGGER SPACER - 74100
19		101-1008	KNIFE GUARD
20		429-0690	M8 X 30MM LG. HH
21		429-0936	M6 X 16 MM LG. SH SST
22		429-0612	KNIFE CLEVIS 7290
23		100-1339	KNIFE CYLINDER 74100
24		105-0126	FLAPPER PIN 1/2 DIA. X 3/16" LG. SST
25		129-0882	M5 X 1.6MM LG. SH SST
26		129-0882	M5 X 1.6MM LG. SH SST
27		129-0922	M8 X 30 MM LG. SH SST
28		139-0290	GROOVE PIN 1/4 DIA. X 1 1/2" 2A SST
29		319-0804	M8 X 40 MM LG. HH SST DIN 931
30		139-0513	GROOVE PIN 3/16 X 1 #4
31		219-0564	M6 X 16 MM LG. FH SST
32		219-1014	M8 X 10MM LG. SEFCREW CUPPT SST
33		419-1072	M6 X 20 MM LG. BH SST
34		199-1183	6MM ID FLAT WASHER SST
35		199-1245	6MM ID LOCKWASHER SST
36		219-0410	M8 X 18 MM LG. SH SST NYLOCK
37		219-0925	M8 X 35 MM LG. SH SST
38		219-1544	M5 X 12MM LG. FH SST
39		129-0881	M5 X 1.6MM LG. SH SST
40		129-0881	M5 X 1.6MM LG. SH SST
41		199-1186	1/8 ALUM. PIER PLUG SST
42		128-9135	1/8 ALUM. PIER PLUG SST
43		132-1566	KNIFE PISTON GUARD
44		219-0672	M6 X 25 MM LG. HH SST DIN 933
45		119-0056	TRIGGER
46		219-0765	M5 X 30 MM LG. HH SST DIN 931
47		121-0308	TRIGGER VALVE C040127
48		219-1184	8MM ID FLAT WASHER SST
49		219-1101	M6 X 6MM LG. SEFCREW NYLON TP SST
50		129-0689	M8 X 25 MM LG. HH SST DIN 933
51		199-2609	1/16 FLAT WASHER SST
52		199-2490	DOVEL PIN 1/8 DIA. X 1/2 SST
53		199-1182	8MM ID FLAT WASHER SST
54		109-0448	PUNCH CLEVIS GUARD
55		219-1039	M5 X 8 MM LG. BH SST
56		428-0353	MALE CONNECT. HEX KGS06-015 (M)
57		318-0199	MALE ELBOW KQ104-015 (M)
58		104-0162	DIE SUPPORT - 74100 R.H.
59		128-0990	1/8 HEX NIPPLE #2169-2
60		121-0150	PRESSURE SENSING VALVE RV-1
61		128-0300	UNION TEE KQ106-00 (M)
62		128-0479	UNION TEE KQ106-00
63		128-0479	UNION TEE KQ106-00
64		128-2551	1/8 STREET ELBOW SS-2-SE
65		110-2218	CLIPPER MOUNT
66		199-0757	M5 X 6 MM LG. HH SST
67		199-0694	PART NUMBER TAG
68		219-4683	1/2 X 3/16 LG. RND HEAD U-TYPE SCR

ORDER BY DATE	SG 2-16-00	APPROVAL DATE	DM 2-16-00	RECORD IT DATE	BKD 2-16-00	DATE	REV. NO.	REV. DATE	REV. DESCRIPTION	REV. BY	REV. DATE	REV. DESCRIPTION	REV. BY
CLIPPER MODEL	74100HR	DATE	74100HR-01	DATE	74100HR-01	DATE	1	DATE	1-1	DATE	1-1	DATE	1-1

NOTES *****
 1. USE 6MM BLACK TUBING 28-0435
 2. SHIP HOSE ASSY 28-4636
 3. CLIPPER LABEL 99-0595
 4. USE BLUE LOCTITE (242) EXCEPT WHERE NOTED

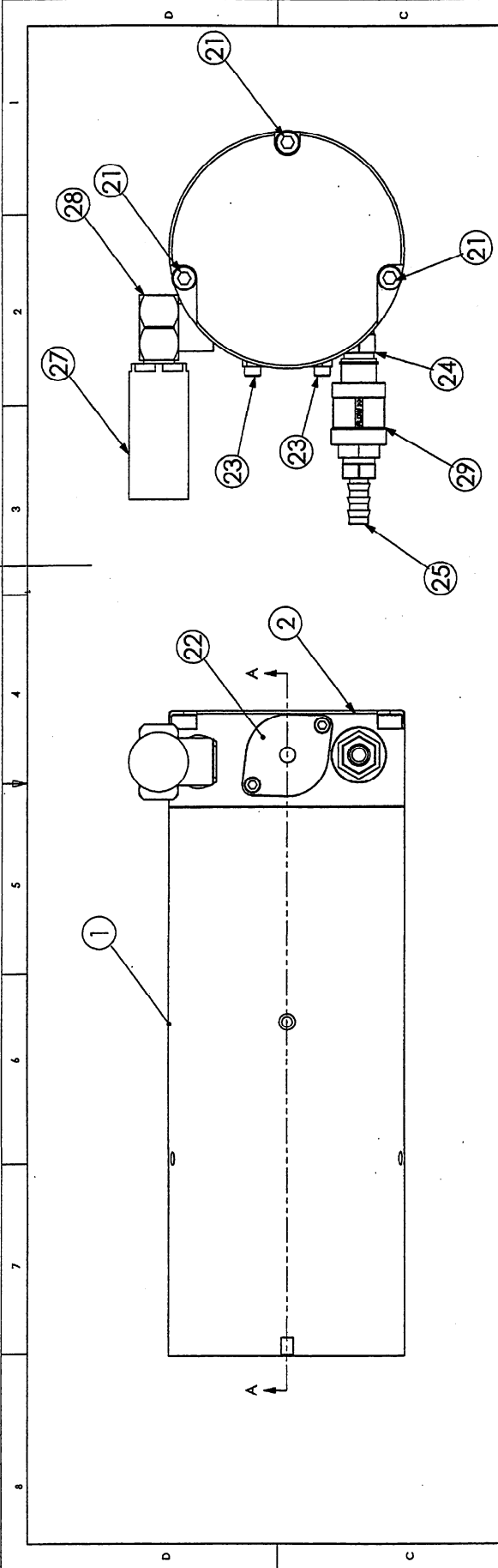

ITEM NO.	QTY.	PART NO.	DESCRIPTION
1	1	104-0382	PUNCH CYLINDER BODY - 4"
2	1	104-0380	PUNCH CYLINDER CAP TOP - 4"
3	1	12-0100	INNER ROD ASSEMBLY
4	1	162-0063	2-115 O-RING 3/32 X 0.880 OD
5	1	12-0101	PUNCH MAIN PISTON
6	1	140-0091	U-CUP #8508-0350
7	1	12-0102	PUNCH PISTON STOP
8	1	140-0092	U-CUP #8404-0075
9	1	140-0090	AURORA WEAR STRIP .062X.187X3.08
10	1	162-2706	2-011 O-RING 1/16 X 0.441 OD
11	1	129-0416	5/16-24 X 3/4 LG FH SST
12	1	12-0114	4" PISTON GLAND
13	1	129-0415	RETAINER RING SMALLLEY#VH-75-S02
14	1	129-0413	RETAINER RING SMALLLEY#VHM-137502
15	1	162-0078	2-028 O-RING 1/16 X 1.504 OD
16	1	162-0078	2-114 O-RING 3/32 X .818 MRS25GS
17	1	138-0351	DURALON BUSHING 5/8X23/32X1/4
18	1	162-2733	2-330 O-RING 3/16 X 2.520 OD
19	1	162-0072	2-028 O-RING 1/16 X 1.629
20	1	162-0408	2-240 O-RING 1/8 X 4.012 OD
21	3	29-0829	M8 X 55 MM LG SH SST
22	1	32-1621	VALVE COVER
23	2	29-0884	M5 X 10 MM LG SH SST
24	1	128-9093	3/8 HEX NIPPLE #219P-6
25	1	128-9066	3/8 QCK DISC NPL 3/8NPT ML #BH2E
26	1	121-0075	Y500 CARTRIDGE VALVE
27	1	128-0579	MUFFLER - 3/8 NPT
28	1	128-0578	MUFFLER FITTING
29	1	121-0330	3/8 NPT LOCKOUT SLIDE VALVE

CONTROL RESOURCES		AURORA # S4916	
VENDOR		VENDOR PART NO.	
VENDOR ADDRESS		bkd T-31-00	
DATE APPROVED		Sigsfiggs T-31-00	
DATE APPROVED		MADE BY DATE	
DATE APPROVED		i. Wojcik T-31-00	
DATE APPROVED		SCALE	
DATE APPROVED		1:1	
DATE APPROVED		REV. NO.	
DATE APPROVED		00-1337-01	
DATE APPROVED		REV. 1 OF 2	

A SUBSTITUTE ITEM SHALL NOT BE USED WITHOUT PRIOR TESTING AND APPROVAL BY ENGINEERING

SOURCE CONTROL DRAWING

4" CYL. AIR RETURN

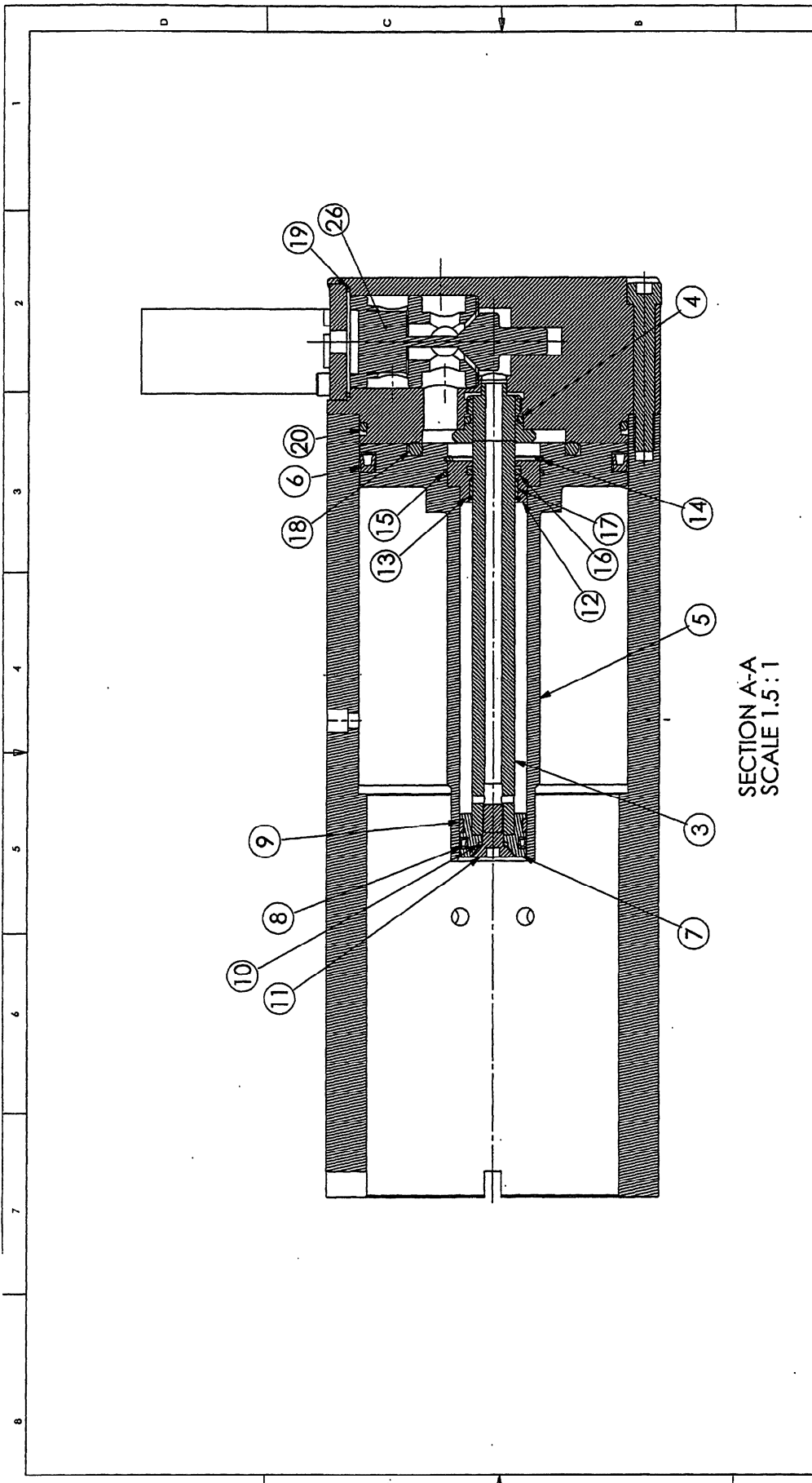

SECTION A-A
SCALE 1.5:1

CONTROL RESOURCES		AURORA # S4916		A SUBSTITUTE ITEM SHALL NOT BE USED WITHOUT PRIOR TESTING AND APPROVAL BY ENGINEERING	
VENDOR		VENDOR PART NO.		SOURCE CONTROL DRAWING	
		SW		4" CYL. AIR RETURN	
		B. Digeso 1-31-00		REV. NO. 00-1337-01	
		TIPPER TIE		DATE 11/11/00	
		Schiffgrs 1-31-00		DATE 11/11/00	
		h. wrojck 1-31-00		DATE 11/11/00	
		RELEASED AT REV 01 2-1-00		DATE 2-1-00	
		NO. 1		DATE	
		APPROVED		DATE	
		DESCRIPTION		REVISIONS	

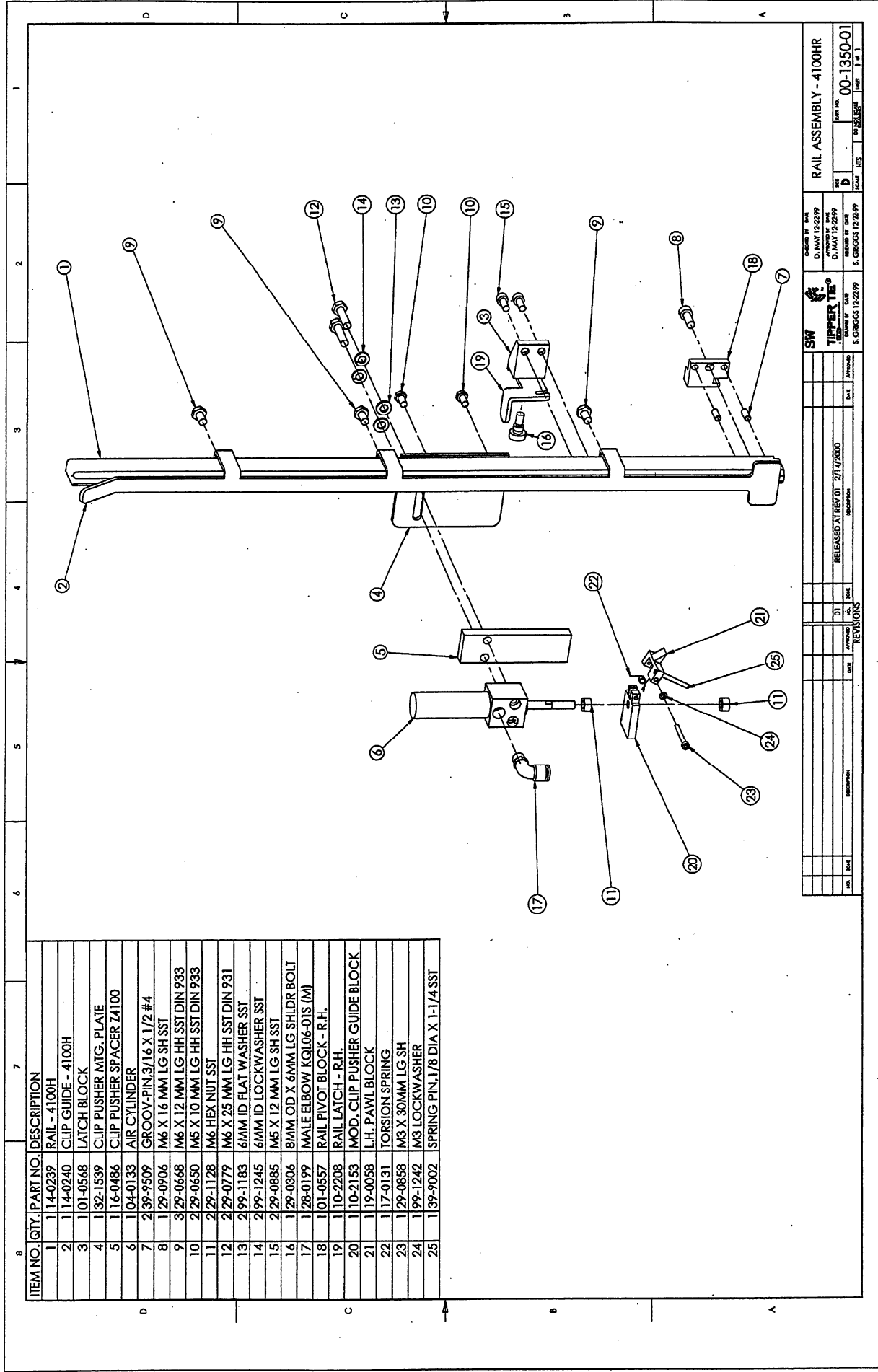

ITEM NO.	QTY.	PART NO.	DESCRIPTION
1	1	14-0239	RAIL - 4100H
2	1	14-0240	CLIP GUIDE - 4100H
3	1	01-0568	LATCH BLOCK
4	1	32-1539	CLIP PUSHER MITG. PLATE
5	1	16-0486	CLIP PUSHER SPACER Z4100
6	1	04-0133	AIR CYLINDER
7	2	39-9509	GROOV. PIN, 3/16 X 1/2 #4
8	1	29-0906	M6 X 16 MM LG SH SST
9	3	29-0668	M6 X 12 MM LG HH SST DIN 933
10	2	29-0650	M5 X 10 MM LG HH SST DIN 933
11	2	29-1128	M6 HEX NUT SST
12	2	29-0779	M6 X 25 MM LG HH SST DIN 931
13	2	99-1183	6MM ID FLAT WASHER SST
14	2	99-1245	6MM ID LOCKWASHER SST
15	2	29-0885	M5 X 12 MM LG SH SST
16	1	29-0306	8MM OD X 6MM LG SHLDR BOLT
17	1	28-0199	MALE ELBOW KQ106-01S (M)
18	1	01-0557	RAIL PIVOT BLOCK - R.H.
19	1	10-2208	RAIL LATCH - R.H.
20	1	10-2153	MOD. CLIP PUSHER GUIDE BLOCK
21	1	19-0058	L.H. PAWL BLOCK
22	1	17-0131	TORSION SPRING
23	1	29-0858	M3 X 30MM LG SH
24	1	99-1242	M3 LOCKWASHER
25	1	39-9002	SPRING PIN, 1/8 DIA X 1-1/4 SST

RAIL ASSEMBLY - 4100HR

DATE	BY	APPROVED	DESCRIPTION
01			RELEASED AT REV 01 2/11/2000

SW

TRIPPER TIE

DATE	BY	APPROVED	DESCRIPTION
D. MAY 192999			
D. MAY 192999			
S. GREGGCS 12-2999			
S. GREGGCS 12-2999			

SCALE: 1:1

USED ON

Z2105

Z2115

Z4135

Z4136

28-9063 1 REQ'D.
3/8 MALE BARB PM-13 BN

28-9969 96" ± 2" REQ'D.
3/8 ID PARKER 801 HOSE

28-9066 1 REQ'D.
3/8 BARB SOCKET 1714 BN

M82

REV. 1

3/8 SUPPLY HOSE x 8 FT
28-4636 5-26-77



Cleveland Range, LLC.

1333 East 179th Street

Cleveland, OH 44110

Phone: (216) 481-4900

Fax: (216) 481-3782

<http://www.clevelandrange.com>

CLIPPER VAC & CLIPPER

Steam Requirements

- Line sizes
- Phase
- Amp. draw

Air Requirements

- Line size
- Pressures
- Check lubricator
- Check for leaks

Clipper Mounting

Model no. _____

Serial no. _____

Comments: