

Installation Instructions

Water Board Replacement for P/N 23198 Using Field Kit Part Number FK23198

The Installation of Cleveland Range Water Board Field Kit should only be performed by Cleveland Range authorized technicians. Read entire installation procedure before beginning. This kit is intended for the replacement of Water Board P/N 23198 with P/N 300821 Water Board Assembly.

23198 Field Kit (P/N FK23198) PARTS LIST

ITEM	QUANTITY	PART NUMBER	DESCRIPTION
1	1	300821	WATER BOARD ASSEMBLY
2	1	300822	LABEL W/D SUPPLEMENTAL
3	1	260BFK	INSTRUCTIONS, INSTALLATION
4	4	20351*	TERMINAL FEM. 0.250" X 0.032"

*NOTE: THESE TERMINALS ARE ONLY TO BE USED IN THE EVENT THAT THE TERMINALS ON THE MACHINE DO NOT FIT THE TERMINALS ON THE WATER BOARD ASSEMBLY'S WIRES.



1333 East 179th Street
Cleveland, Ohio 44110

Phone: 216-481-4900
Fax: 216-481-3782
www.clevelandrange.com

 **Cleveland**

300821 Water-Board Assembly Installation

1. REMOVE THE 23198 WATER BOARD. RETAIN THE FOUR MOUNTING SCREWS.
2. MOUNT THE 300821 WATER BOARD ASSEMBLY USING THE ORIGINAL FOUR MOUNTING SCREWS.
3. TRANSFER WIRES FROM 23198 WATER BOARD TO 300821 WATER BOARD ASSEMBLY AS FOLLOWS:
4. FROM (PROBE-C) ON BOARD 23198 TO (GRN) WIRE SUPPLIED ON BOARD ASSEMBLY 300821.
5. FROM (PROBE-LOW) ON BOARD 23198 TO (YEL) WIRE SUPPLIED ON BOARD ASSEMBLY 300821.
6. FROM (PROBE-HIGH) ON BOARD 23198 TO (BLK) WIRE SUPPLIED ON BOARD ASSEMBLY 300821.
7. FROM (WATER FILL) ON BOARD 23198, CONNECT EXISTING WIRE TO RELAY Y1 N.O. ON BOARD ASSEMBLY 300821.
8. FROM (HEATER) ON BOARD 23198, CONNECT EXISTING WIRE TO RELAY Y2 N.O. ON BOARD ASSEMBLY 300821.
9. FROM (INDICATOR) ON BOARD 23198, CONNECT EXISTING WIRE TO RELAY Y2 N.C. ON BOARD ASSEMBLY 300821.
10. FROM (L1) ON BOARD 23198 TO (RED) WIRE SUPPLIED ON BOARD ASSEMBLY 300821.
11. FROM (L2) ON BOARD 23198, CONNECT EXISTING WIRE TO L2 ON BOARD ASSEMBLY 300821.

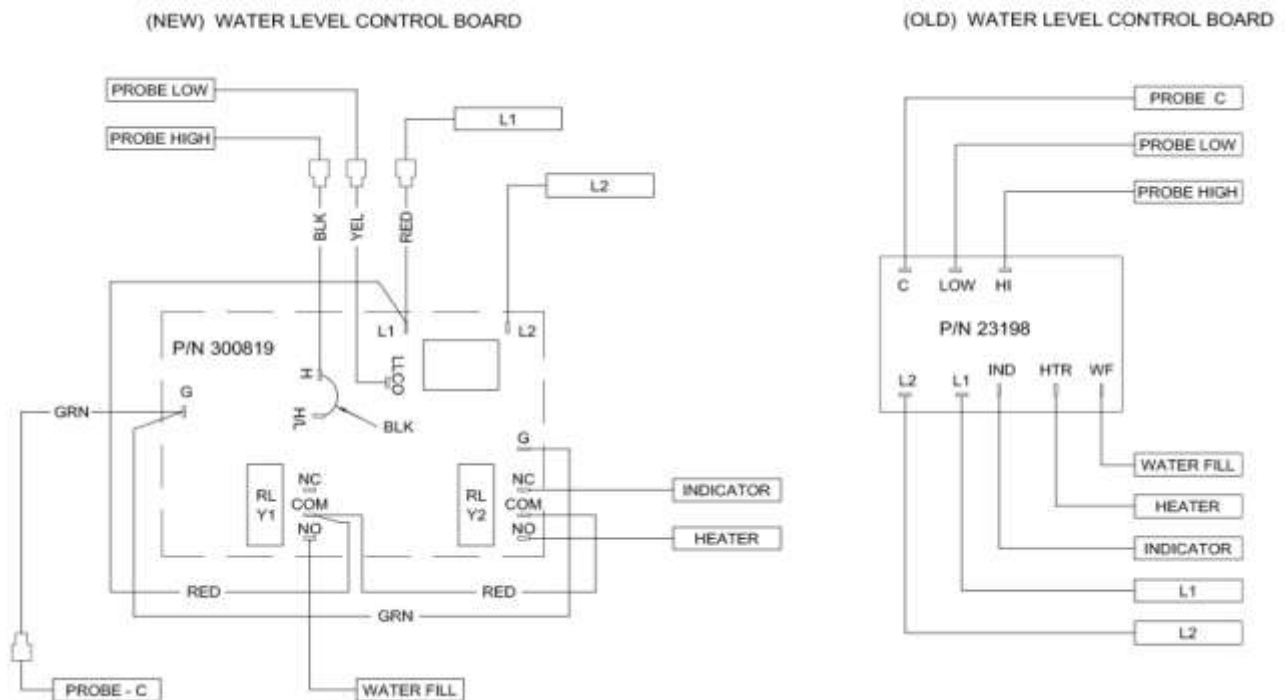

Figure 1
WIRING COMPARISON OF NEW BOARD AND ORIGINAL BOARD

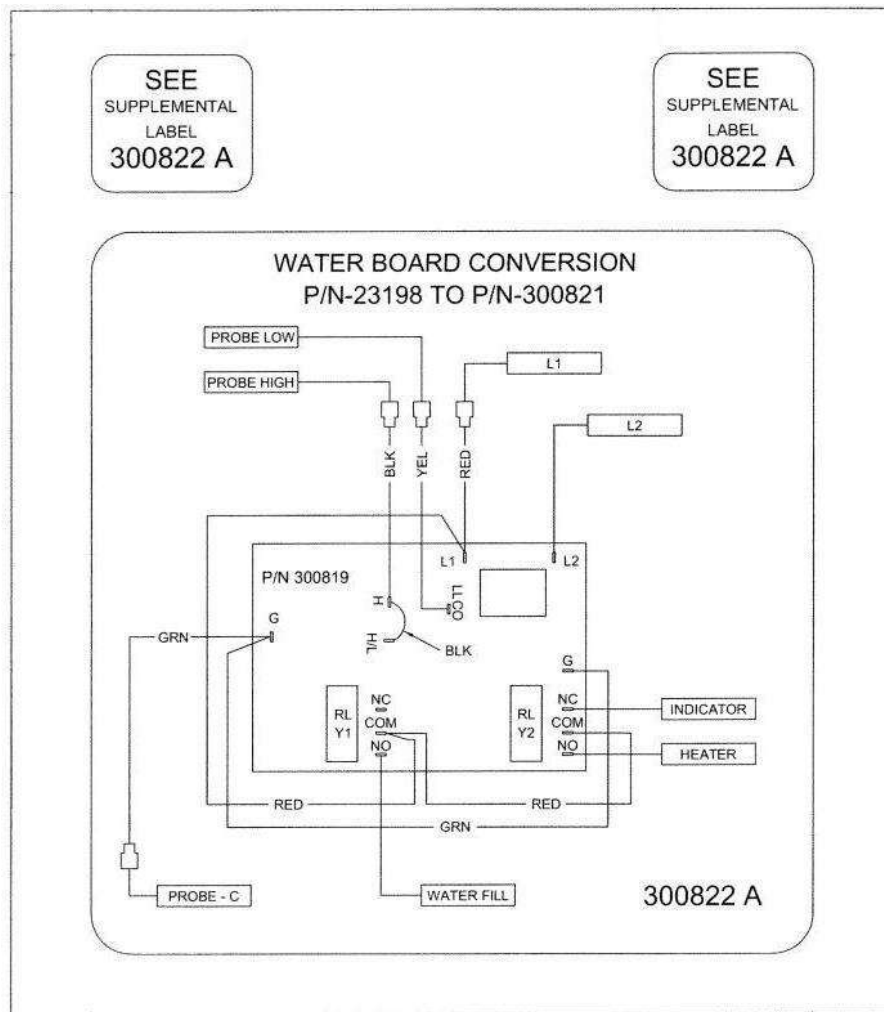

Figure 2
LABELS TO APPLY TO THE MACHINE

12. APPLY THE LARGER LABEL, P/N 300822A MARKED "WATER BOARD CONVERSION" NEAR TO THE MACHINE'S EXISTING WIRING DIAGRAMS.
13. APPLY SMALLER LABELS MARKED "SEE SUPPLEMENTAL LABEL" OVER THE WATER BOARD GRAPHIC ON THE MACHINE'S ORIGINAL LADDER DIAGRAM AND/OR POINT TO POINT WIRING DIAGRAM.

This Page for Internal Record Only, Not for Printing

Cleveland Range, LLC

1333 East 179th St, Cleveland, Ohio 44110

Drawing No. 260BFK

Revision Index Page

LET	REVISION HISTORY	DATE	BY
A	RELEASE PER ECO # 10-313	1/20/2011	MDS