

VACON TO ABB DRIVE REPLACEMENT MANUAL

WIRING CONNECTIONS FOR ABB DRIVE:

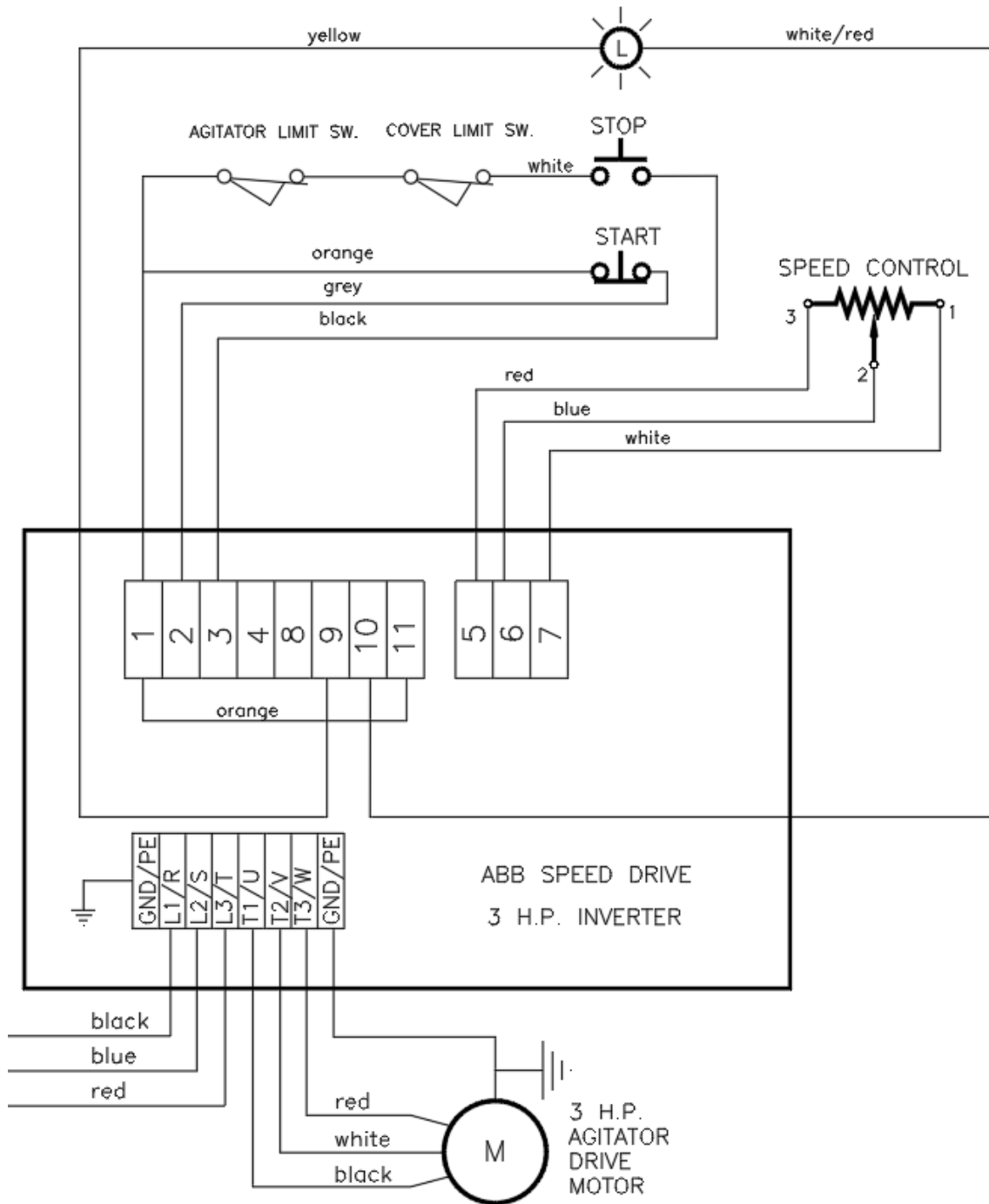

WIRING CONNECTION PICTURES FOR REFERENCE:

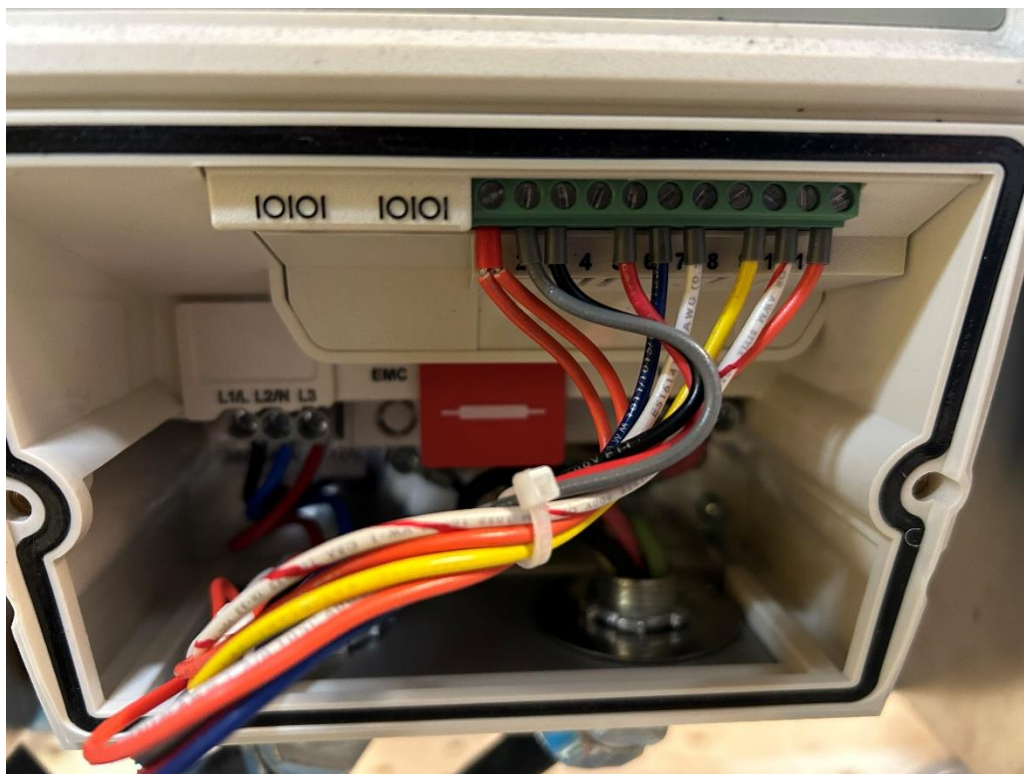
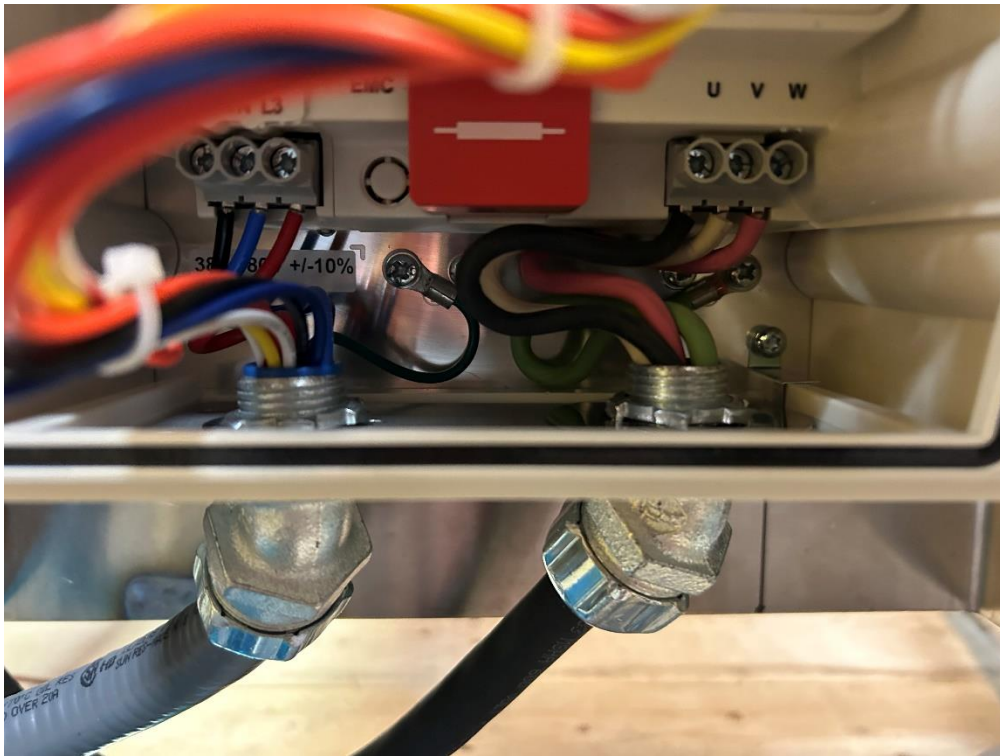

HORIZONTAL MIXER KETTLES - AC INVERTER PROGRAMMING INSTRUCTIONS

1. Parameter Structure

The parameters within the drive are split into 3 groups, group 1 is titled "Short Parameter mode" displayed as "Par S" on the drive display, group 2 is titled "Long Parameter mode" displayed as "Par L" on the drive display and group 3 is titled "Advanced Parameter mode" displayed as "Par A".

- "Par S" group brings together the most commonly used parameters to aid quick setup.
- "Par L" group includes all of the drive parameters (except those in "Par-A" group).
- "Par A" group includes the drives advanced functions.

Group Navigation.

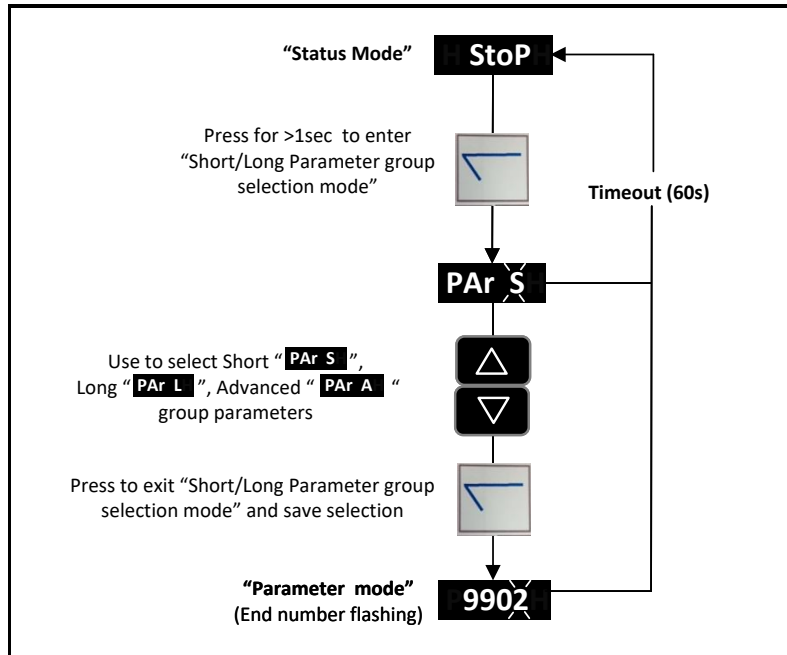

Parameter Structure table.

PAr S	PAr L	PAr A
Parameter No.	Parameter No.	Parameter No.
9902	0000	2017
9905	0401	2105
9906	1100	2106
9907	1103	2301
0401	1202	2605
1103	1203	9903
1202	1204	9910
1203	1205	11201
1204	3400	11203
1301	4001	11206
2008	4002	
2102	4005	
2202	4010	
	4011	
	4016	
	5302	
	9902	
	9905	
	9906	
	9907	
	9908	

10.2. Parameters in the Short parameter mode

The following table describes the parameters that are visible in the Short parameter mode. See page 25 for how to select the parameter mode. All parameters are presented in detail in section 10.4.

Parameters in the Short parameter mode			
No.	Name/Value	Description	Def
99 START-UP DATA			
Application macros.			
9902	DIGITAL INPUTS FUNCTION SELECT	Defines the function of the digital inputs depending on the control mode setting in Parameter 1103 PRIMARY COMMAND SOURCE MODE. See Application macros on page 28.	10
9905	MOTOR RATED VOLTAGE	This parameter should be set to the rated (nameplate) voltage of the motor (Volts).	Drive Rating Dependent
	110V/230V rated drives 0...255V	Voltage	
	400V rated drives 0...500V	Note : The stress on the motor insulation is always dependent on the drive supply voltage. This also applies in the case where the motor voltage rating is lower than the rating of the drive and the supply of the drive.	
9906	MOTOR RATED CURRENT	This parameter should be set to the rated (nameplate) current of the motor.	Drive Rating Dependent
	0.2*drive rated output current...1.0*drive rated output current	Current	
9907	MOTOR RATED FREQUENCY	This parameter should be set to the rated (nameplate) frequency of the motor	60Hz
	25...500Hz	Frequency	
04 FAULT HISTORY			
Fault history (read only)			
0401	TRIP HISTORY LOG	Displays the last four fault codes for the drive. Refer to page 50 for further information.	-
11 REFERENCE SELECT			
The drive can accept a variety of references in addition to the conventional analog input, potentiometer and keypad signals.			
1103	PRIMARY COMMAND SOURCE MODE		0: Terminal Control
	0: TERMINAL CONTROL.	The drive responds directly to signals applied to the control terminals.	
	1: UNI-DIRECTIONAL KEYPAD CONTROL	The drive can be controlled in the forward direction only using an external or remote Keypad	
	2: BI-DIRECTIONAL KEYPAD CONTROL.	The drive can be controlled in the forward and reverse directions using an external or remote Keypad. Pressing the keypad START button toggles between forward and reverse.	
	3: MODBUS NETWORK CONTROL.	Control via Modbus RTU (RS485) using the internal accel / decel ramps	
	4 : MODBUS NETWORK CONTROL.	Control via Modbus RTU (RS485) interface with accel / decel ramps updated via Modbus	
	5 : PI CONTROL	User PI control with external feedback signal	
	6 : PI ANALOG SUMMATION CONTROL.	PI control with external feedback signal and summation with analog input 1	
12 CONSTANT SPEEDS			
Constant speeds. Constant speed activation overrides the external speed reference. Constant speed selections are ignored if the drive is in the local control mode.			
Refer to section 9.1 for how to make constant speed selections from the drive control terminals.			
Preset Speeds / Frequencies selected by digital inputs depending on the setting of Parameter 9902 DIGITAL INPUTS FUNCTION SELECT. If Parameter 9908 MOTOR RATED SPEED = 0, the values are entered as Hz. If Parameter 9908 > 0, the values are entered as Rpm. Setting a negative value will reverse the direction of motor rotation.			
1202	PRESET / JOG FREQUENCY / SPEED 1	Defines constant speed 1 (that is the drive output frequency)	5.0Hz/RPM
	2007...-2008	Output Frequency	
1203	PRESET / JOG FREQUENCY / SPEED 2	Defines constant speed 2 (that is the drive output frequency)	10.0Hz/RPM
	2007...-2008	Output Frequency	
1204	PRESET / JOG FREQUENCY / SPEED 3	Defines constant speed 3 (that is the drive output frequency)	25.0Hz/RPM
	2007...-2008	Output Frequency	

Parameters in the Short parameter mode			
No.	Name/Value	Description	Def
13 ANALOG INPUTS			
1301	ANALOG INPUT 1 OFFSET	Sets an offset, as a percentage of the full scale range of the input, which is applied to the analog input signal	0.0%
	-500...500 %	Value in percent of the full scale range of the input Example: If the analog input signal format is 0-10V, offset = 20% . An analog input signal level of 7 Volts gives the following result :- Analog input level (%) = 7/10 = 70% Result = 70-20 (%) = 50%	
20 LIMITS			
2008	MAXIMUM FREQUENCY / SPEED LIMIT	Maximum output frequency or motor speed limit – Hz or rpm. If parameter 9908 MOTOR RATED SPEED >0, the value entered / displayed is in Rpm	60.0 Hz
	2007 ...500.0 Hz	Maximum frequency	
21 START/STOP			
2102	STOP MODE	Selects the motor stop function	0 = Ramp to stop
	0 : RAMP TO STOP	When the enable signal is removed, the drive will ramp to stop, with the rate controlled by parameter 2203 DECEL RAMP TIME as described above. In this mode, the drive brake transistor is disabled	
	1 : COAST TO STOP	When the enable signal is removed, the drive output is immediately disabled, and the motor will coast (freewheel) to stop. If the load can continue to rotate due to inertia, and the drive may possibly be re-enabled whilst the motor is still rotating, the spin start function (Parameter 2101 SPIN START ENABLE) should be enabled. In this mode, the drive brake transistor is disabled.	
	2 : RAMP TO STOP	When the enable signal is removed, the drive will ramp to stop, with the rate controlled by Parameter 2203 DECEL RAMP TIME as described above. The ACS255 Brake chopper is also enabled in this mode.	
	3 : COAST TO STOP	When the enable signal is removed, the drive output is immediately disabled, and the motor will coast (freewheel) to stop. If the load can continue to rotate due to inertia, and the drive may possibly be re-enabled whilst the motor is still rotating, the spin start function (Parameter 2101 SPIN START ENABLE) should be enabled. The drive brake chopper is enabled in this mode, however it will only activate when required during a change in the drive frequency setpoint, and will not activate when stopping.	
22 ACCEL/DECEL			
2202	ACCELERATION RAMP TIME	Acceleration ramp time from 0 to base speed (Parameter 9907 MOTOR RATED FREQUENCY) in seconds.	5.0 s
	0.00...600.0 s	Time	
2203	DECELERATION RAMP TIME	Deceleration ramp time from base speed (Parameter 9907 MOTOR RATED FREQUENCY) to standstill in seconds. When set to zero, fastest possible ramp time without trip is activated.	1.0 s
	0.00...600.0 s	Time	
14 RELAY OUTPUTS			
1401	OUTPUT RELAY FUNCTION SELECT	Selects the function assigned to the relay output. The relay has two output terminals, Logic 1 indicates the relay is active, and therefore terminals 10 and 11 will be linked together.	0
	0 : DRIVE ENABLED (RUNNING)	Logic 1 when the motor is enabled	
	1 : DRIVE READY	Logic 1 when power is applied to the drive and no fault exists	
	2 : AT TARGET FREQUENCY (SPEED)	Logic 1 when the output frequency matches the setpoint frequency	
	3: DRIVE TRIPPED	Logic 1 when the drive is in a fault condition	
	4 : OUTPUT FREQUENCY >= LIMIT	Logic 1 when the output frequency exceeds the adjustable limit set in 3200 RELAY THRESHOLD LEVEL	
	5 : OUTPUT CURRENT >= LIMIT	Logic 1 when the motor current exceeds the adjustable limit set in 3200 RELAY THRESHOLD LEVEL	
	6 : OUTPUT FREQUENCY < LIMIT	Logic 1 when the output frequency is below the adjustable limit set in 3200 RELAY THRESHOLD LEVEL	
	7 : OUTPUT CURRENT < LIMIT	Logic 1 when the motor current is below the adjustable limit set in 3200 RELAY THRESHOLD LEVEL	