

Installation Instructions

UNISTAND34 Equipment Stand for
SteamCraft®, SteamChef™ Electric kit P/N 111721
SteamCub™ kit P/N 111721CUB
SteamChef™ Gas Steamers kit P/N 111721GCHEF

The Installation of Cleveland Range steamers on this stand should only be performed by Cleveland Range authorized technicians. Read entire installation procedure before beginning.

KIT P/N 111721 for installing a UNISTAND34 with a SteamCraft® models 21CET8, 21CET16, 21CGA5 or a Steamchef Model 22CET3.1, 22CET6.1; PARTS LIST

Item No.	Part No.	Description	Quantity
1	260AZE	Instructions for Installing Steamers on Unistand34	1
2	111765	Unistand34 Equipment Stand Assembly	1
3	107220	Washer, Fender, 13/32" ID, 1½" OD, SST	4
4	WR50167	Washer, Lock, 3/8", SST	4
5	19134	Screw, Hex Head, 3/8-16 x 1" Long, SST	4
6	111013	Washer, Fender, 17/32" ID x 1½" OD, SST	4
7	23153	Washer, Lock, ½, SST	4
8	111012	Screw, Hex Head, ½-13 x 3/4" Long, SST	4

KIT P/N 111721CUB for installing a UNISTAND34 with a SteamCub models 1SCE or 1SCEMCS PARTS LIST

Item No.	Part No.	Description	Quantity
1	260AZE	Instructions for Installing Steamers on Unistand34	1
2	111765	Unistand34 Equipment Stand Assembly	1
3	109189	Nut, Special, Cub Stand Mounting, ¾-10 UNC, SST	4
4	109193	Washer, 1-1/16" ID x 2" OD x 1/8" Thick, SST	4

KIT P/N 111721GCHEF for installing a UNISTAND34 with a Gas SteamChef model 22CGT3.1 or 22CGT6.1 PARTS LIST

Item No.	Part No.	Description	Quantity
1	260AZE	Instructions for Installing Steamers on Unistand34	1
2	111765	Unistand34 Equipment Stand Assembly	1
3	111012	Screw, Hex Head, ½-13 x 3/4" Long, SST	4
4	111013	Washer, Fender, 17/32" ID x 1½" OD, SST	4
5	111892	Adapter, Stand, Gas Chef	4
6	23153	Washer, Lock, ½"	4

See Pages 2 - 3 for Installation of SteamCraft® Steamers

See Pages 4 - 5 for Installation of SteamCub™ Steamers

See Pages 6 - 7 for Installation of SteamChef™ ELECTRIC Steamers

See Pages 8 - 10 for Installation of SteamChef™ GAS Steamers

1333 East 179th Street
Cleveland, Ohio 44110
Phone: (216) 481 - 4900
1-800-338-2204
Fax: (216) 481 - 3782
www.clevelandrange.com



SteamCraft® Steamer Installation (Models 21CET8, 21CET16, 21CGA5 KIT P/N 111721)

In addition to knowledge of this procedure, installer must be familiar with the instructions supplied with each SteamCraft® Steamer. These instructions are Cleveland Range P/N 21CET-INM (Model 21CET8 and Model 21CET16) and 21CGA5-INM (Model 21CGA5).

1. Position stand in selected location so that feet with round mounting pads are at the rear. Use adjustable feet to level stand front-to-back and side-to-side.
2. Set steamer directly on stand as shown in Figure 2 on the next page (4-inch legs provided with steamer are not used when installing SteamCraft® steamers on a stand). Align steamer so that front mounting bolts will come up through holes marked "A" in Figure 1 below.

NOTE: It is especially important when installing a gas fired steamer that the bottom ventilation holes line up with those in the stand (See Figure 1 below). Be sure that these holes line up before securing gas steamer to stand.

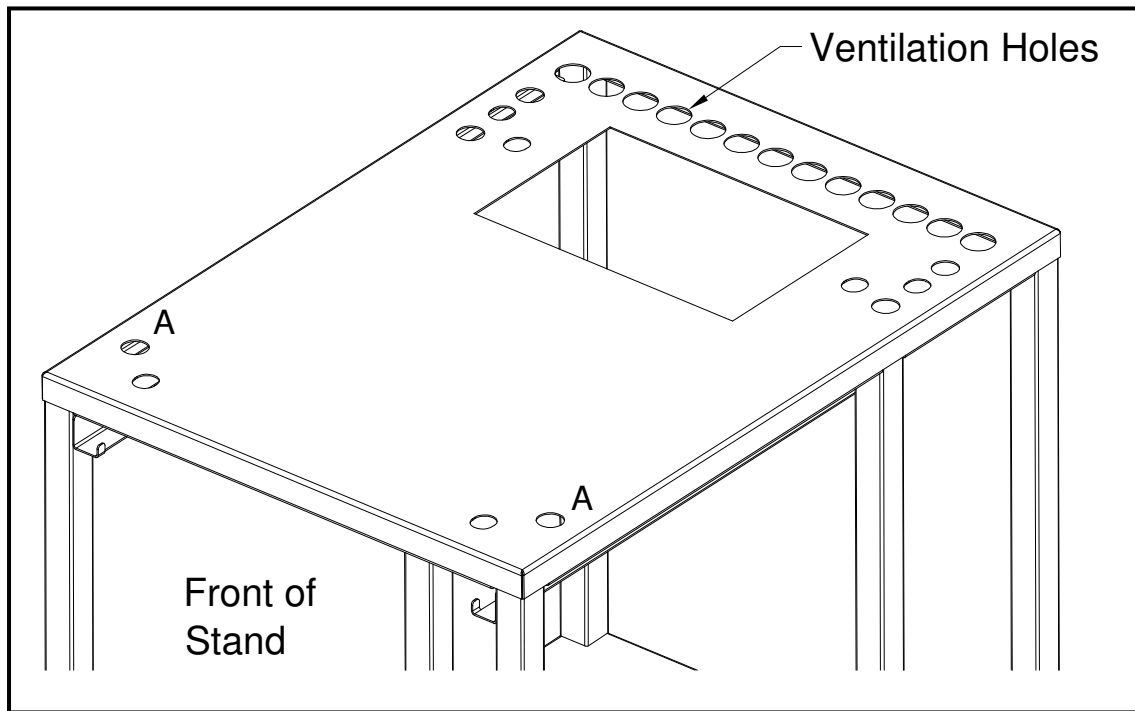

Figure 1
Ventilation Holes for Gas Steamers

3. Secure steamer to stand using 4 sets of bolts and washers provided as shown in Figure 2 (Items 2, 3 and 4) on the following page.
4. Remove the control "side" side panel and seal any gaps between steamer and stand with a suitable RTV Sealant (not provided) as shown in Figure 2. Suitable RTV sealant is a Food Grade silicone sealant rated at least 250°F and Listed or Classified to the ANSI/NSF 51 or 61 Standards. Replace side panel.
5. Complete installation of steamer as outlined in its installation manual.

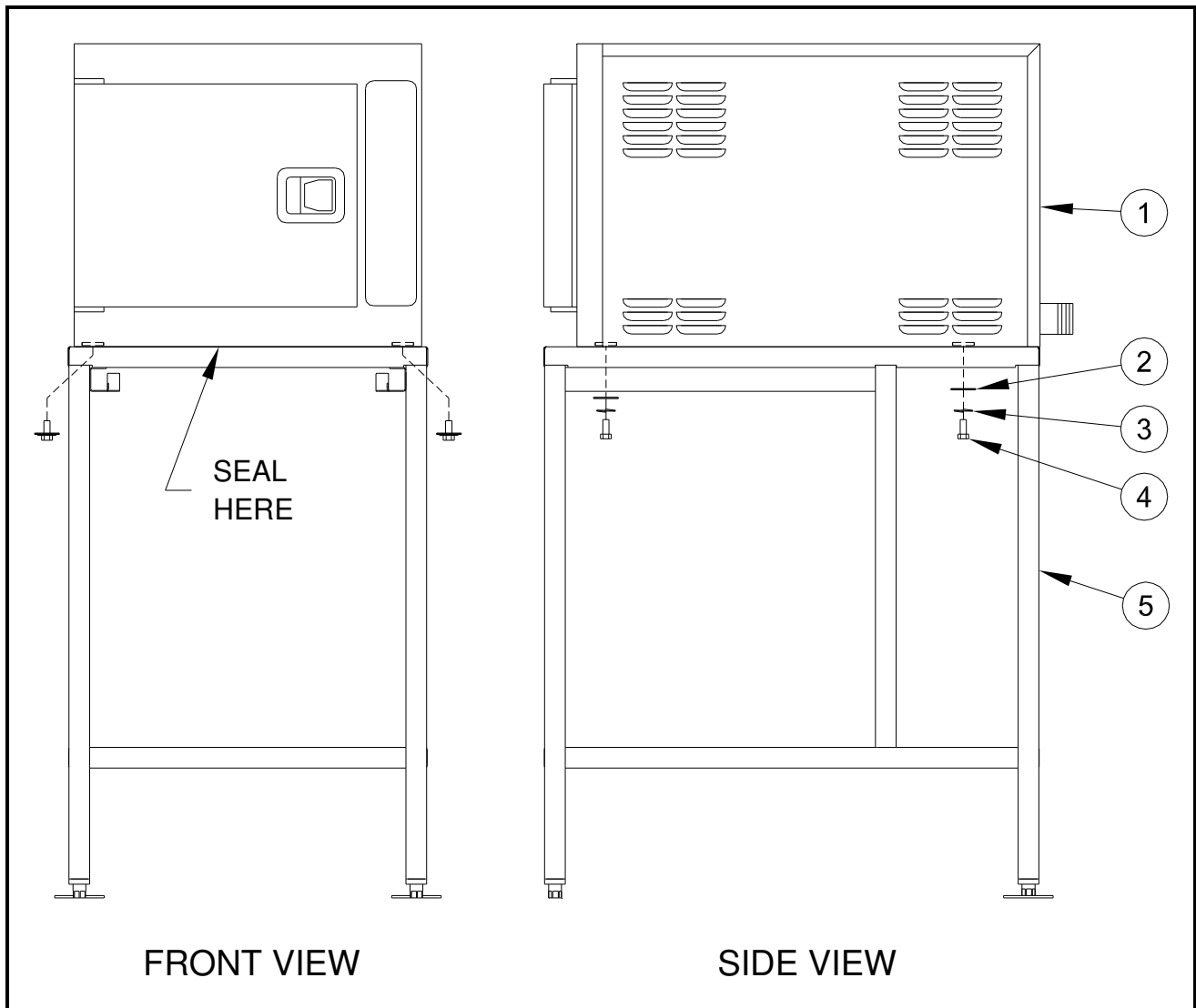

Figure 2
SteamCraft® Mounting Instructions
(Model 21CET8 shown on Unistand34)

1	-	SteamCraft® Steamer (SteamCraft® 21CET8 Shown)	1
2	107220	Washer, Fender, 13/32" ID, 1½" OD, SST	4
3	WR50167	Washer, Lock, 3/8", SST	4
4	19134	Screw, Hex Head, 3/8-16 x 1" Long, SST	4
5	111765	Unistand34 Equipment Stand Assembly	1
Item No.	Part No.	Description	Quantity

SteamCub™ Steamer Installation

(Model 1SCE and 1SCEMCS KIT P/N 111721CUB)

In addition to knowledge of this procedure, installer must be familiar with the instructions supplied with each SteamCub™ steamer. These instructions are part of Cleveland Range P/N 1SCE-INM.

An optional Top Cover Kit, P/N 111728, is available for the stand. If this cover is being used, it must be installed before SteamCub™ is placed on stand.

1. Position stand in selected location so that feet with round mounting pads are at the rear. Use adjustable feet to level stand front-to-back and side-to-side.
2. Place optional top cover, if used, on stand so that four holes in cover line up with holes in stand (See Figure 3). Refer to separate instruction 260AYZ for sealing cover to stand.
3. Place the four washers provided onto stand over the four SteamCub™ mounting holes (See Figure 3).

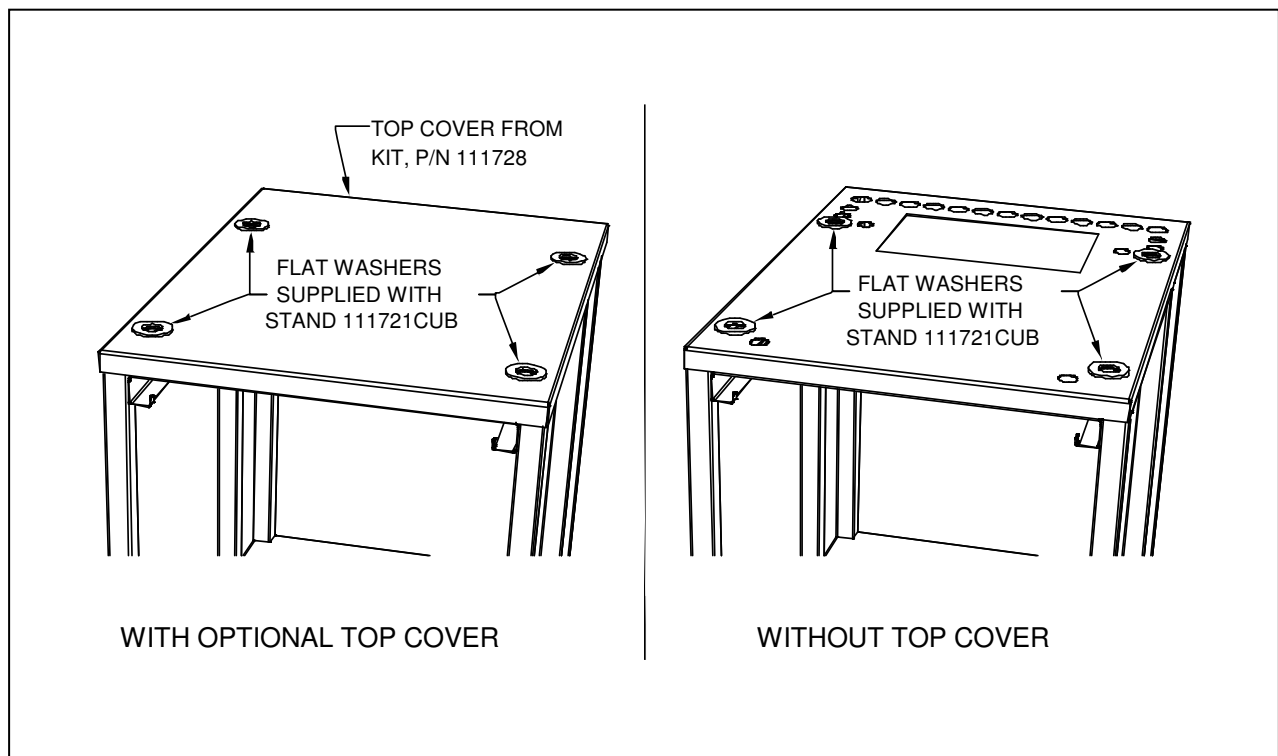
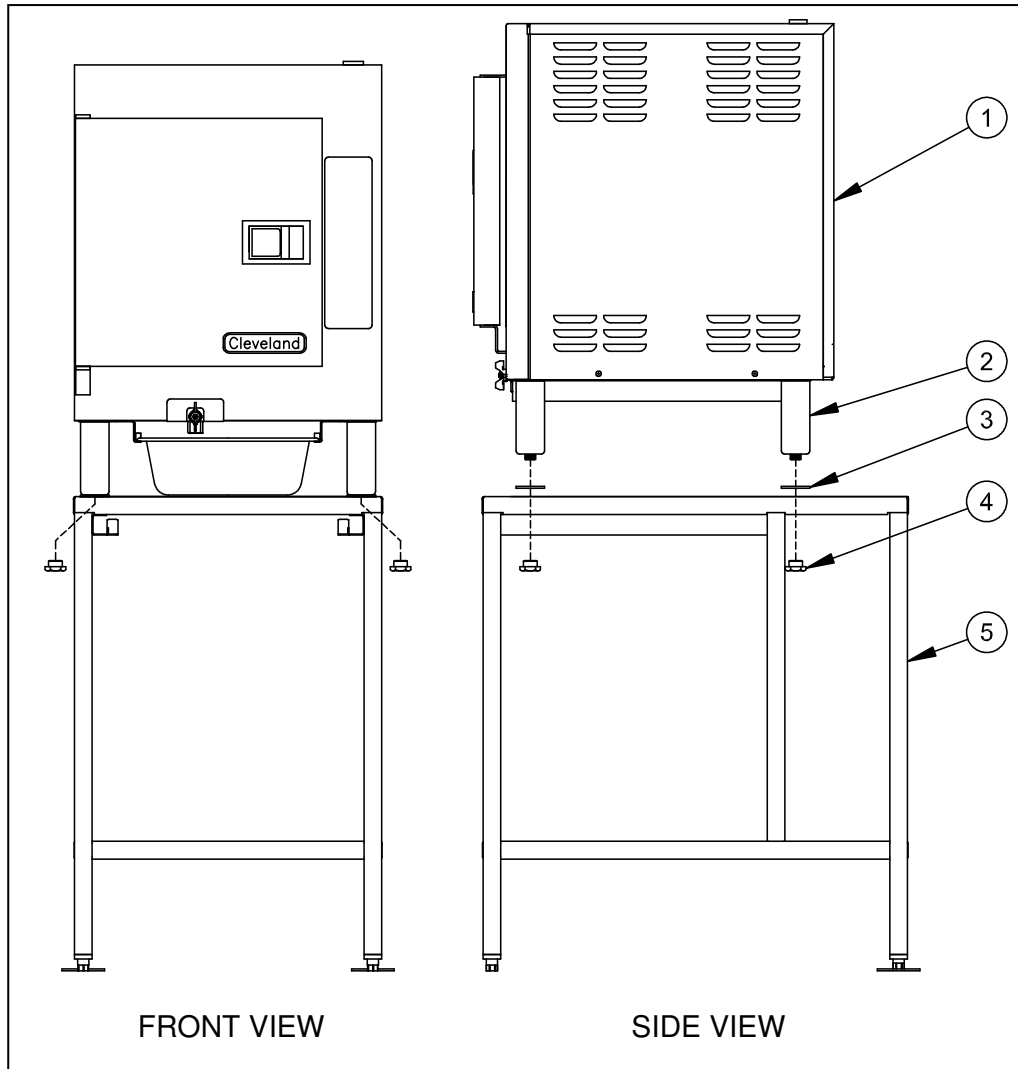

Figure 3
SteamCub™ Mounting Washer Placement

4. Screw four legs provided with SteamCub™ into nuts inside bottom of steamer as shown in Figure 4 (Item 2) on the following page.
5. Completely unscrew the coated flanged foot from each leg and set steamer onto stand so that legs are resting on mounting washers with studs passing through holes in top of stand. See Figure 4.

6. Secure steamer to stand using four special nuts (Item 4) provided in the kit as shown in Figure 4. Tighten special nuts so that they extend through mounting washer and into leg as necessary to secure steamer to stand.
7. Complete installation of steamer as outlined in its installation manual.



*Supplied-with or Part of SteamCub™ Steamer

Figure 4
SteamCub™ Mounting Instructions
(Model 1SCE shown on Unistand34)

1	-	SteamCub™ Steamer (SteamCub™ 1SCE Shown)	1
2	061623*	Leg, 6", with Coated Flanged Foot (foot removed)	4
3	109193	Washer, 1-1/16" ID x 2" OD x 1/8" Thick, SST	4
4	109189	Nut, Special, Cub Stand Mounting, 3/4-10 UNC, SST	4
5	111765	Unistand34 Equipment Stand Assembly	1
Item No.	Part No.	Description	Quantity

SteamChef™ ELECTRIC Steamer Installation (Models 22CET3.1, 22CET6.1 KIT P/N 111721)

In addition to knowledge of this procedure, installer must be familiar with the instructions supplied with each SteamChef™ Steamer. These instructions are Cleveland Range P/N 22CET(ES)-OPM.

1. Position stand in selected location so that feet with round mounting pads are at the rear. Use adjustable feet to level stand front-to-back and side-to-side.
2. Set steamer directly on stand as shown in Figure 6 on the next page (4-inch legs provided with steamer are not used when installing Electric SteamChef™ steamers on a stand). Align steamer so that rear mounting bolts will come up through holes marked “B” in Figure 5 below.

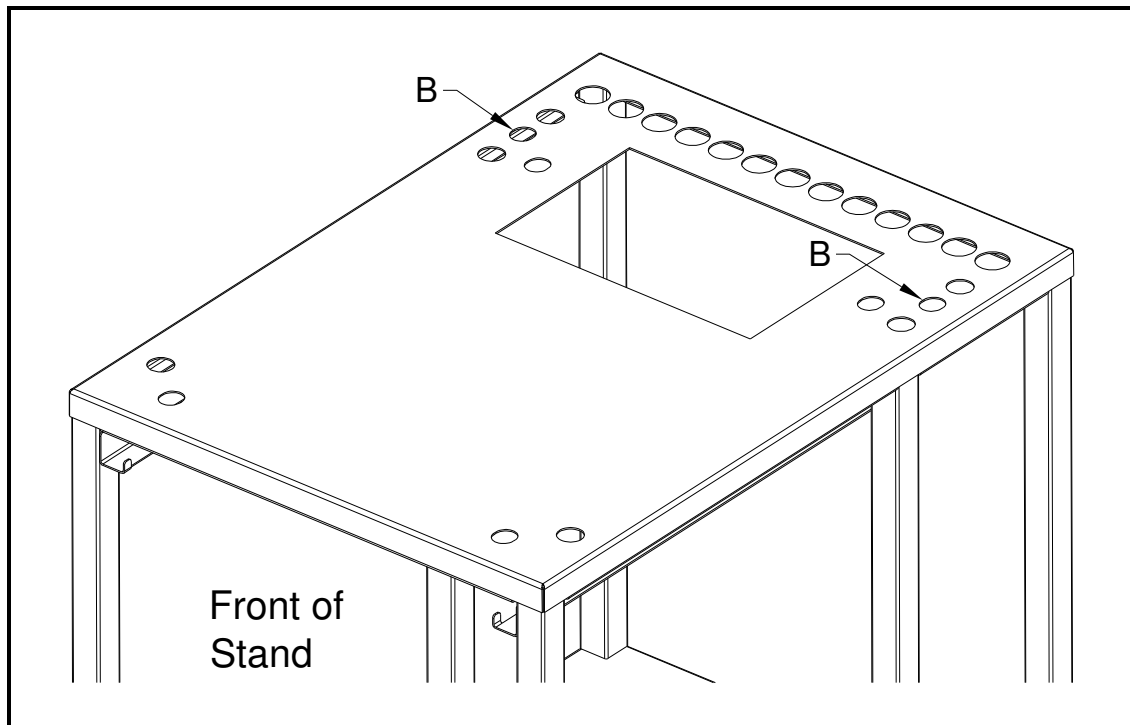

Figure 5
SteamChef™ Mounting Holes

3. Secure steamer to stand using 4 sets of bolts and washers provided as shown in Figure 6 (Items 2, 3 and 4) on the following page.
4. Remove control “side” side panel and seal any gaps between steamer and stand with a suitable RTV Sealant (not provided) as shown in Figure 6. Suitable RTV sealant is a Food Grade silicone sealant rated at least 250°F and Listed or Classified to the ANSI/NSF 51 or 61 Standards. Replace side panel.
5. Complete installation of steamer as outlined in its installation manual.

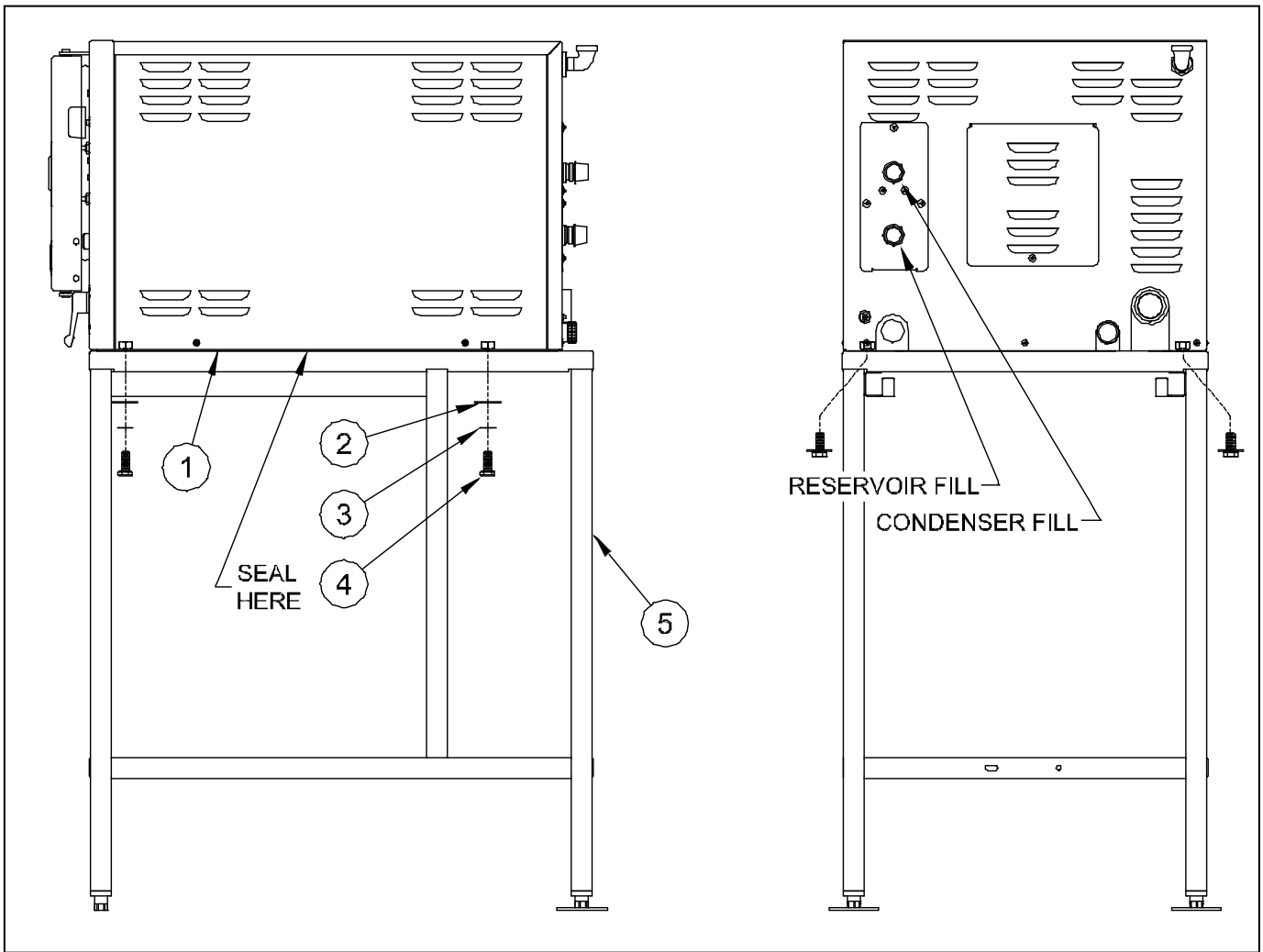

Figure 6
SteamChef™ Mounting Instructions
(Model 22CET3.1 shown on Unistand34)

1	-	SteamChef™ Steamer (SteamChef™ 22CET3.1 shown)	1
2	111013	Washer, Fender, 17/32" ID x 1½" OD, SST	4
3	23153	Washer, Lock, ½", SST	4
4	111012	Screw, Hex Head, ½-13 x ¾" Long, SST	4
5	111765	Unistand34 Equipment Stand Assembly	1
Item No.	Part No.	Description	Qty.

SteamChef™ GAS Steamer Installation (Models 22CGT3.1 and 22CGT6.1 Kit P/N 111721GCHEF)

In addition to knowledge of this procedure, installer must be familiar with the instructions supplied with each SteamChef™ Steamer. These instructions are Cleveland Range P/N's 22CGT3.1&6.1-OPM and 22CGT3.1&6.1-INM.

An optional Top Cover Kit, P/N 111894, is available for the stand. If this cover is being used, it must be installed before SteamChef™ is placed on stand.

1. Position stand in selected location so that feet with round mounting pads are at the rear. Use the adjustable feet to level the stand front-to-back and side-to-side.
2. Place optional top cover, if used, on stand so that the four holes in cover line up with their corresponding holes in stand (See Figure 8).
3. Set the steamer directly on stand as shown in Figure 8 on the next page.
4. Remove lower flanged foot from each leg and install Stand Adaptors P/N 111892.
5. Align steamer so that mounting bolts come up through holes marked "B" in Figure 7 below.

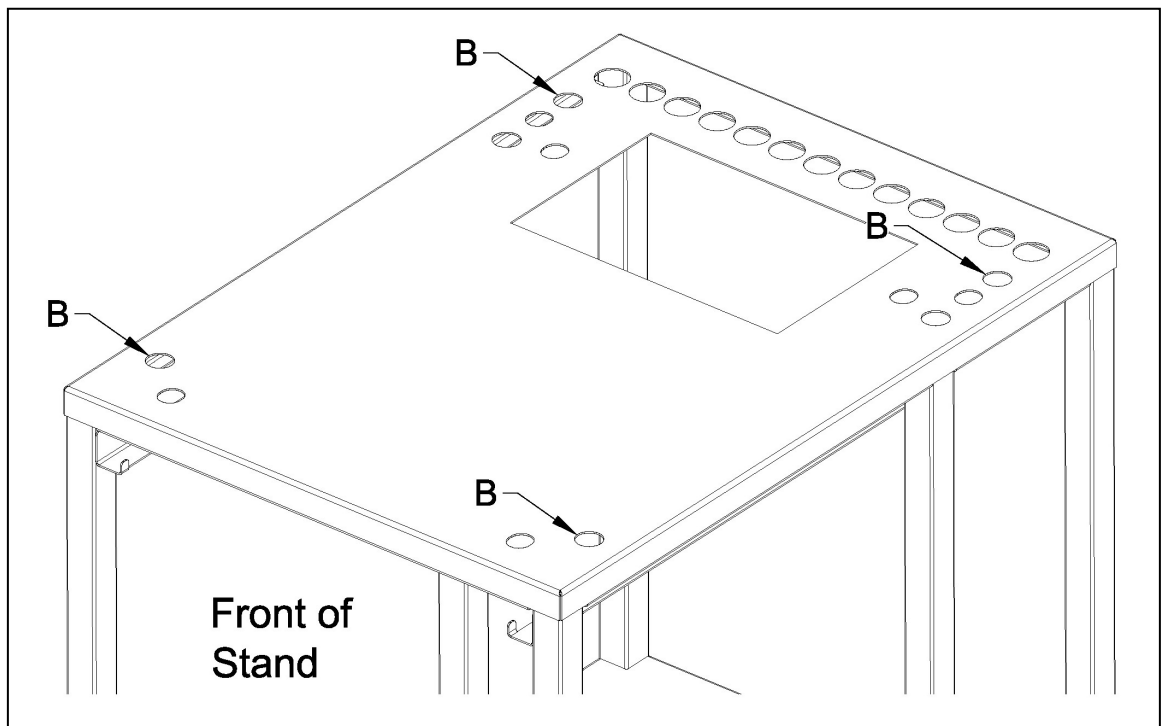

Figure 7
SteamChef™ Gas Mounting Holes

6. Secure steamer to stand according to the instructions in Figure 9 on Page 10.
 - If Optional Top Cover is used, see Figure 8 on Page 9.

SteamChef™ GAS Steamer Installation (Models 22CGT3.1 and 22CGT6.1)

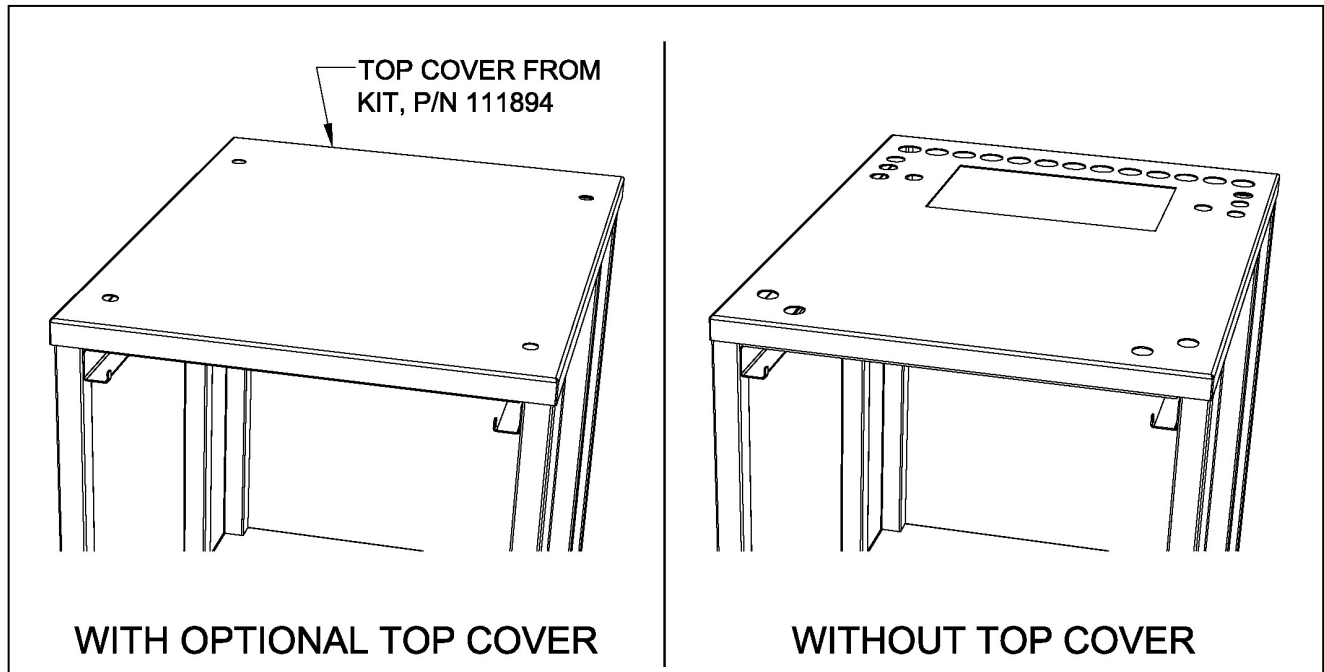

Figure 8
Stand With and Without Optional Top Cover

7. Complete installation of steamer as outlined in its installation manual.
 - If Optional Top Cover is used, refer to separate instruction 260AZN for sealing cover to stand.

SteamChef™ GAS Steamer Installation

(Models 22CGT3.1 and 22CGT6.1)

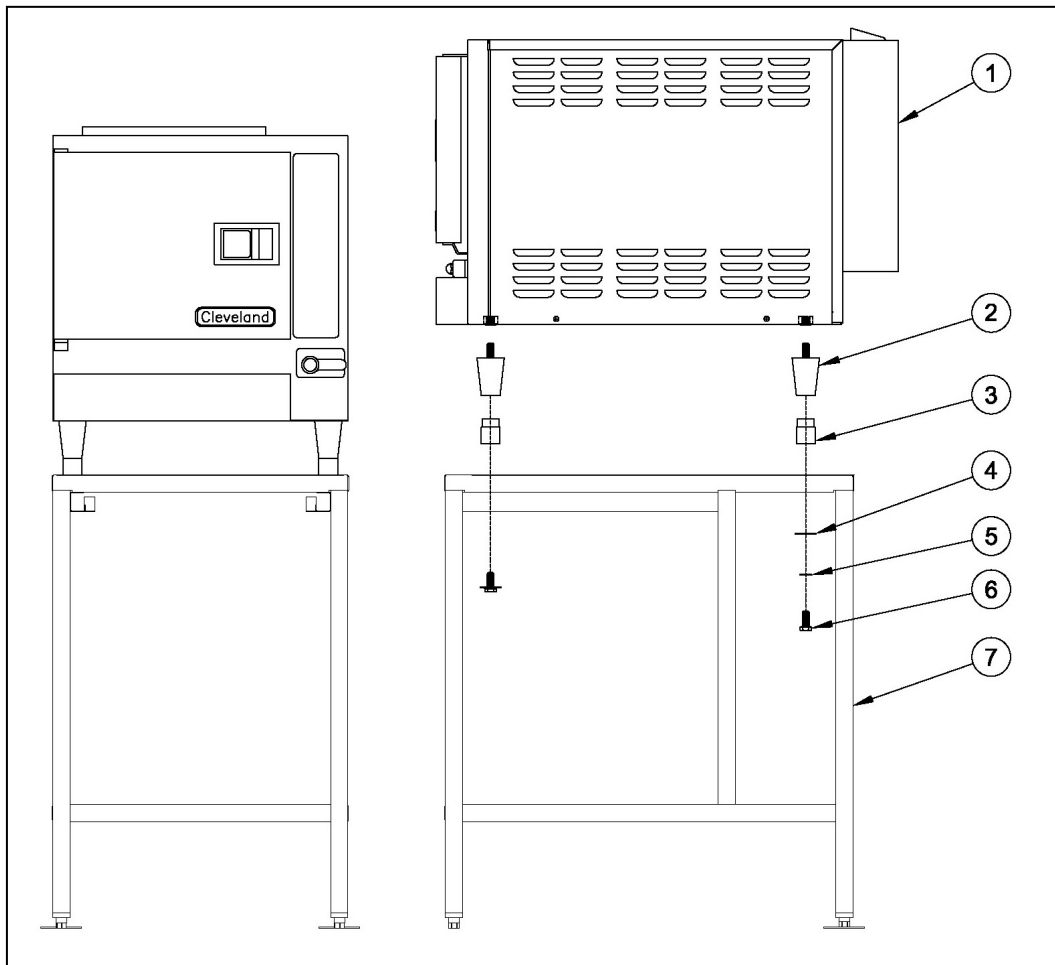

Figure 9
SteamChef™ GAS Mounting Instructions
(Model 22CGT3.1 shown on Unistand34)

*Supplied-with or Part-of SteamChef™ Steamer

1	-	SteamChef™ GAS Steamer (22CGT3.1 shown)	1
2*	111002	Foot, 4.00" Adjustable, Less Flange	4
3	111892	Adapter, Stand	4
4	111013	Washer, Fender	4
5	23153	Washer, Lock	4
6	111012	Screw, Hex Head, ½ -13	4
7	111765	Unistand34	1
Item No.	Part No.	Description	Qty.