

Installation Instructions

UNISTAND25 Equipment Stand for Directly Stacking SteamCraft® and SteamChef™ Steamers

The Installation of Cleveland Range steamers on this stand should only be performed by Cleveland Range authorized technicians. Read entire installation procedure before beginning.

This stand is intended for directly stacking (2) SteamCraft® model 21CET8 steamers* or (2) SteamChef™ model 22CET3A steamers*.

UNISTAND25 (P/N 111717) PARTS LIST

Item No.	Part No.	Description	Quantity
1	260AZF	Instructions for Installing Steamers on Unistand25	1
2	111764	Unistand25 Equipment Stand Assembly	1

***Important:** To directly stack (2) SteamCraft® model 21CET8 Steamers, an additional SteamCraft® Direct Stack Mounting Kit, P/N 107166, will be needed.

To directly stack (2) SteamChef™ model 22CET3A steamers, an additional SteamChef™ Direct Stack Mounting Kit, P/N 111771, will be needed.

The above kits include all the required spacers, brackets, fasteners, hose, and fittings necessary to properly stack these steamers.

Each kit includes its own set of Installation Instructions. These are P/N 260ALA (direct stacked 21CET8 steamers) and 260AZG (direct stacked 22CET3A steamers). Refer to these instructions to complete the direct stacked steamer installation.

1333 East 179th Street
Cleveland, Ohio
44110

Phone: (800) 338-2204
Fax: (216) 481-3782



Installation Instructions

SteamCraft® Direct Stack Mounting Kit for two SteamCraft® 21CET8 Steamers Mounted on a Unistand25 Equipment Stand

The Installation of Cleveland Range steamers on the Unistand25 Equipment Stand should only be performed by Cleveland Range authorized technicians. Read entire installation procedure before beginning.

This kit is intended for mounting (2) SteamCraft® 21CET8 steamers on a Unistand25 Equipment Stand. Do not mount SteamChef™ 22CET3A steamers with this kit. Use kit P/N 111771 to mount SteamChef™ 22CET3A steamers.

SteamCraft® Mounting Kit (P/N 107166) PARTS LIST

Item No.	Part	Description	Q
1	260ALA	Instructions for SteamCraft® direct stack on Unistand25	1
2	19134	Screw, Hex Head, 3/8-16 x 1" Long, SST	4
3	WR5016	Washer, Lock, 3/8", SST	4
4	107220	Washer, Fender, 13/32" ID x 1½" OD, SST	4
5	107090	Bracket, Rear Corner, Stacked SteamCraft® 21CET8	2
6	19288	Screw, Hex Head, ¼-20 x ¾" Long, Plated	4
7	14665	Nut, Hex, Nylock, ¼-20, SST	4
8	02579	Bushing, Hex, 1½" NPT x 1-1/4" NPT, Black	1
9	20221	Tee, 1½" NPT, Black	1
10	05239	Elbow, Reducing, 1½" NPT x 1-1/4" NPT, 90°, Black	1
11	110985	Fitting, 1½" NPT (M) x 1½" Hose, Plated	2
12	1109841	Hose, EPDM, Black, 1½" ID x 2" OD, 11" Long	1
13	102018	Clamp, Hose, Worm Drive, 1½" to 2"	2
14	110817	Elbow, Street, ¼" NPT, 45°, Brass	1
15	14304	Nipple, ¼" NPT x Close, Brass, TBE	2
16	110852	Tee, Reducing, ½" NPT x ¼" NPT x ½" NPT, Brass	2
17	02623	Bushing, Hex, ½" NPT x ¼" NPT, Brass	2
18	109866	Fitting, Hose Barb, Radius Tip, ¼" NPT x ¼" Hose, Brass	4
19	1058501	Hose, Reinforced, Silicone, ¼" ID x 9/16" OD, 19" Long	2
20	1073121	Clamp, Hose, Metal Tension Band, 0.60" to 0.73"	4
21	111704	Fitting, ½" NPT (M) x ¾" GHT (M), Brass	2
22	110987	Strainer Washer, Garden Hose	2
23	107219	Plate, Side Support, Stacked SteamCraft® 21CET8	2

1333 East 179th Street
Cleveland, Ohio 44110

Phone: 216-481-4900
Fax: 216-481-3782
www.clevelandrange.com



SteamCraft® Steamer Direct Stack Installation (Two Model 21CET8 Steamers on Unistand25 Equipment Stand)

In addition to knowledge of this procedure, installer must be familiar with the instructions supplied with each SteamCraft® Steamer. These instructions are Cleveland Range P/N 260API.

1. Position stand in selected location so that feet with round mounting pads are at the rear. Use adjustable feet to level stand front-to-back and side-to-side.
2. Set lower steamer (has 2" hole in top panel) directly on stand as shown in Figure 4 on page 5 (4-inch legs provided with steamer are not used when installing SteamCraft® steamers on a stand). Align steamer so that front mounting bolts will come up through holes marked "A" in Figure 1 below.

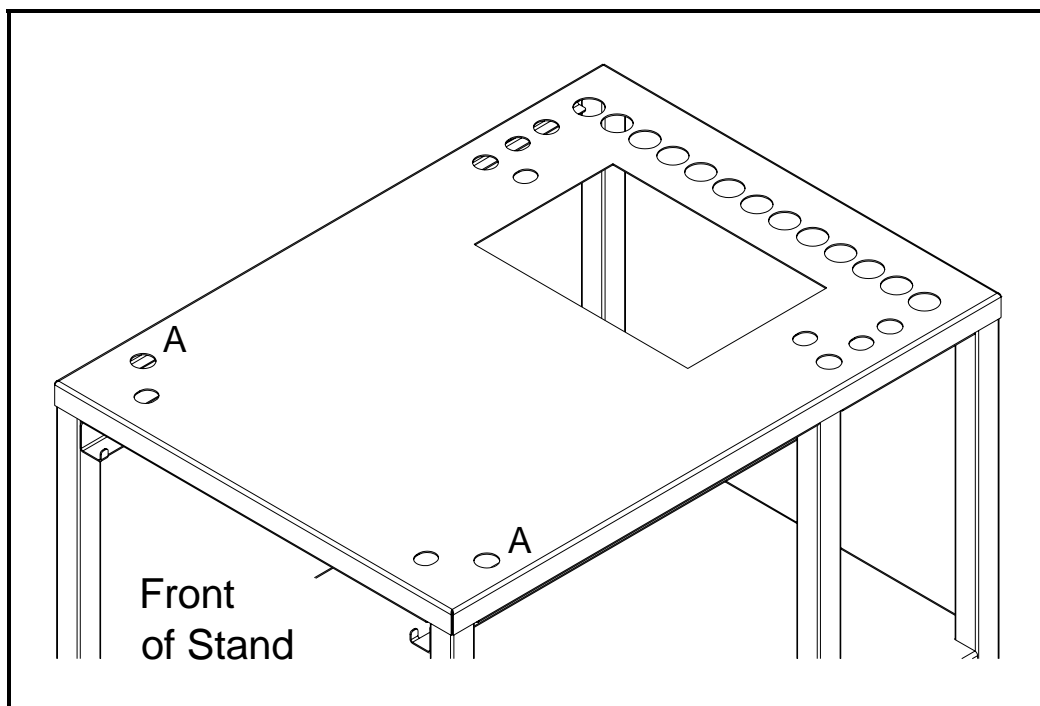

Figure 1
SteamCraft® Mounting Holes

3. Secure lower steamer to stand using 4 sets of bolts and washers provided as shown in Figure 4 (Items 3, 4, and 5) on page 5.
4. Remove right side panel and seal any gaps between steamer and stand with a suitable RTV Sealant (not provided) as shown in Figure 2 on page 3.
5. Remove side panels from upper steamer (has two descale ports in top panel). Do not screw 4" legs into steamer. Place upper steamer directly on top of lower steamer and align it with lower steamer.
6. Route lower steamer descale hose (Item 6, Figure 4) into upper steamer and attach it to open descale port (Item 7, Figure 4) on upper steamer. Secure with clamp provided.

7. Attach rear corner supports as shown in Figure 4 (Item 8) with four sets of screws and nuts (Items 9 and 10, Figure 4).
8. Seal any gaps between upper and lower steamers with RTV sealant (see Figure 2).

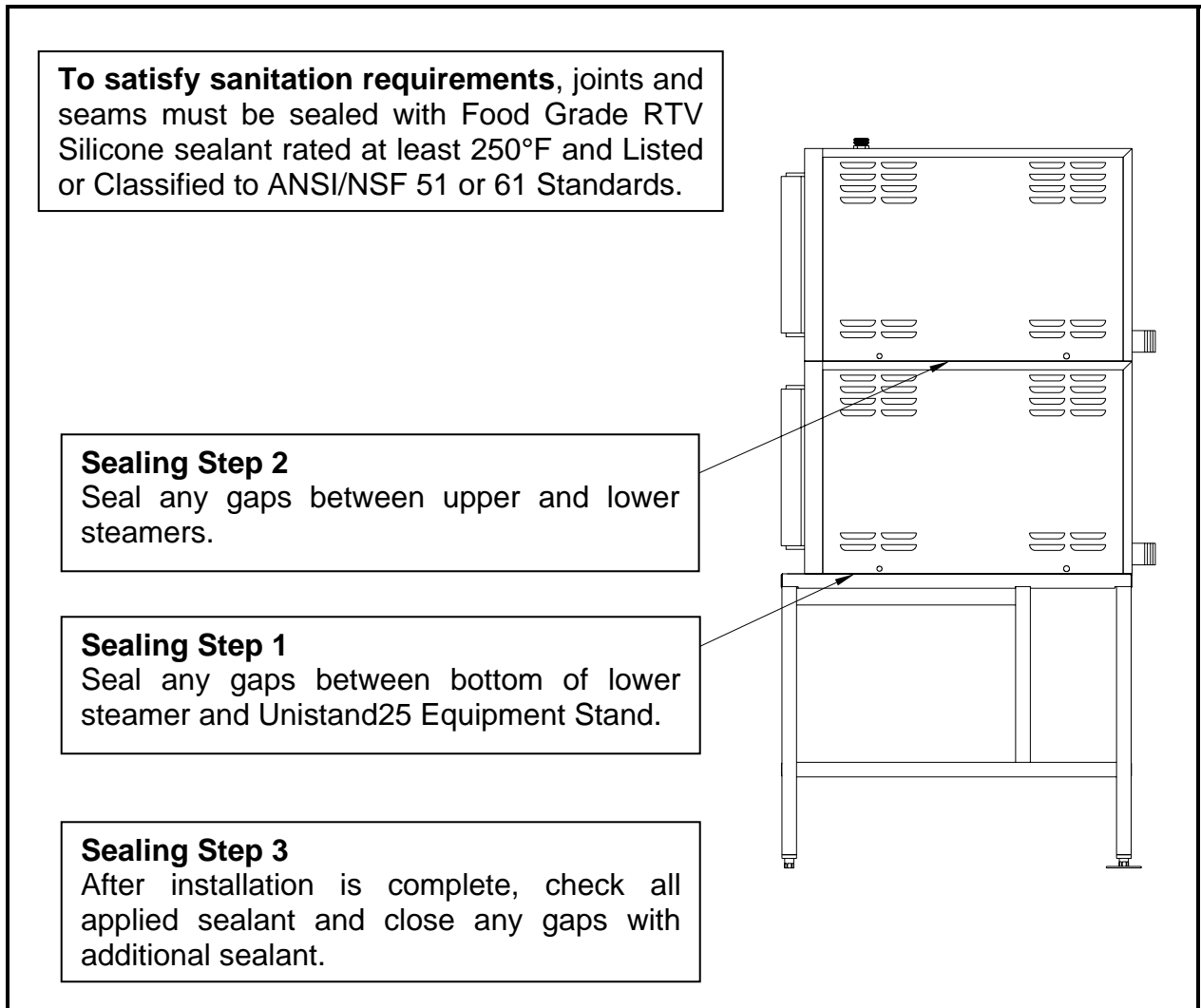

Figure 2
Sealing Requirements

9. Attach drain fittings as shown in Figure 4 (Items 11 - 14) on page 5. Use a suitable pipe thread sealant or Teflon tape (not provided) on all threaded connections.
10. Check length of drain hose (Figure 4, Item 15) and shorten if necessary. Place worm drive clamps (Figure 4, Item 16) over hose and push hose onto upper hose fitting. Slightly rotate lower tee and hose fitting counter-clockwise until lower end of hose can start onto fitting. Slide hose fully onto fitting by rotating tee and fitting back to their original vertical position. Secure hose to fittings with worm drive clamps.

11. Attach inlet water trains for reservoir and condenser as shown in Figure 4 (Items 17 – 25) on page 5. Use a suitable pipe thread sealant or Teflon tape on all NPT threaded connections. Use a suitable plain washer or strainer washer at all Garden Hose threaded connections (DO NOT USE PIPE THREAD SEALANT OR TEFLON TAPE ON GARDEN HOSE THREADED CONNECTIONS).

Note: Strainer washers (Figure 4, Item 25) are supplied for use on the water inlets. THESE STRAINER WASHERS MUST BE USED ON THE STEAMER WATER INLET CONNECTIONS.

12. After RTV sealant has set, replace side panels removed in Steps 4 and 5. Use the upper side panel retaining screws to hold the side supports in place (Item 26, Figure 4 Parts List) as shown below in Figure 3. Do not seal right side support and right side panels to unit. Right side panels must be easily removable for future service access.

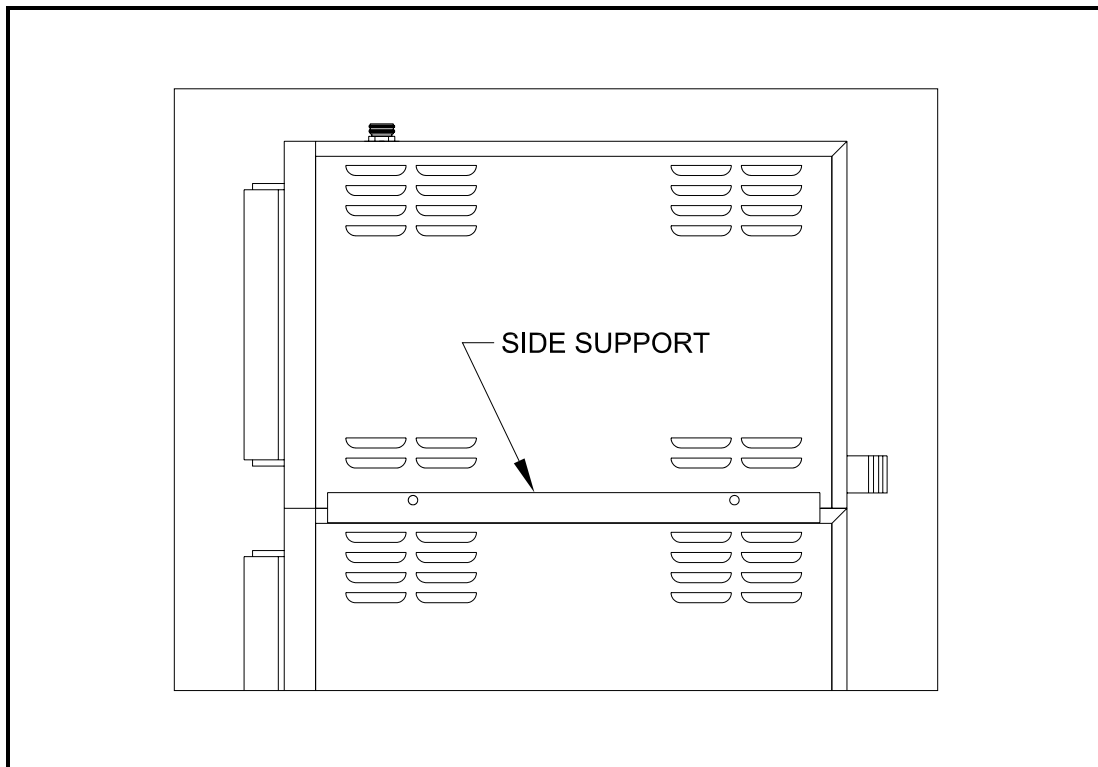
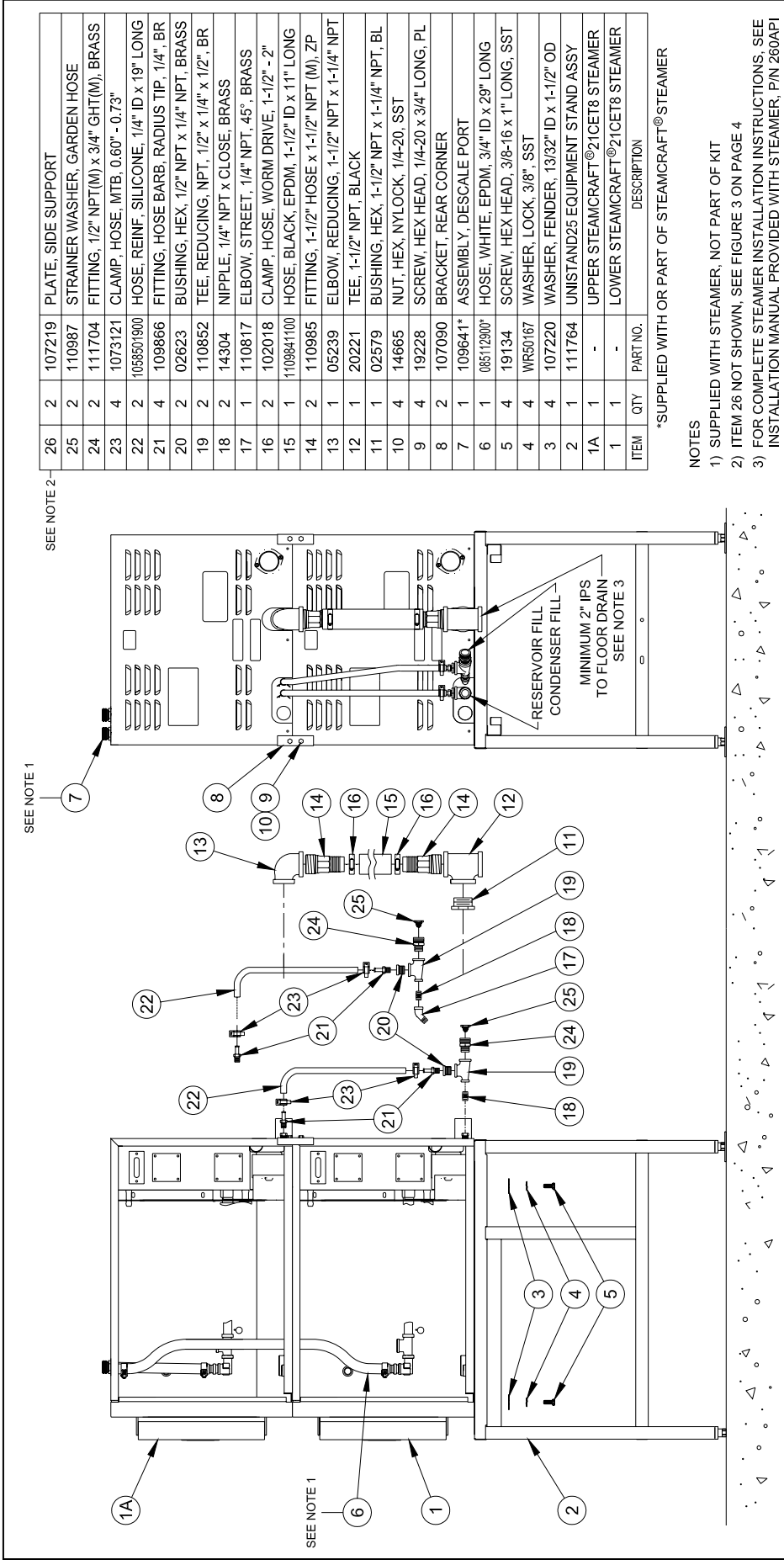

Figure 3
Side Support Attachment

13. Complete installation of steamers as outlined in SteamCraft® Installation Manual, P/N 260API. The stand must be anchored to floor through holes in round mounting pads on rear feet.



ITEM	QTY	PART NO.	DESCRIPTION
26	2	107219	PLATE, SIDE SUPPORT
25	2	110987	STRAINER WASHER, GARDEN HOSE
24	2	111704	FITTING, 1/2" NPT(M) x 3/4" GHT(M), BRASS
23	4	1073121	CLAMP, HOSE, MTB, 0.60" - 0.73"
22	2	1058501900	HOSE, REINF, SILICONE, 1/4" ID x 19" LONG
21	4	109866	FITTING, HOSE BARB, RADIUS TIP, 1/4", BR
20	2	02623	BUSHING, HEX, 1/2" NPT x 1/4" NPT, BRASS
19	2	110852	TEE, REDUCING, NPT, 1/2" x 1/4" x 1/2", BR
18	2	14304	NIPPLE, 1/4" NPT x CLOSE, BRASS
17	1	110817	ELBOW, STREET, 1/4" NPT, 45°, BRASS
16	2	102018	CLAMP, HOSE, WORM DRIVE, 1-1/2" - 2"
15	1	10984100	HOSE, BLACK, EPDM, 1-1/2" ID x 11" LONG
14	2	110985	FITTING, 1-1/2" HOSE x 1-1/2" NPT (M), ZP
13	1	05239	ELBOW, REDUCING, 1-1/2" NPT x 1-1/4" NPT
12	1	20221	TEE, 1-1/2" NPT, BLACK
11	1	02579	BUSHING, HEX, 1-1/2" NPT x 1-1/4" NPT, BL
10	4	14665	NUT, HEX, NYLOCK, 1/4-20, SST
9	4	19228	SCREW, HEX HEAD, 1/4-20 x 3/4" LONG, PL
8	2	107090	BRACKET, REAR CORNER
7	1	109641*	ASSEMBLY, DESCALC PORT
6	1	08512300*	HOSE, WHITE, EPDM, 3/4" ID x 29" LONG
5	4	19134	SCREW, HEX HEAD, 3/8-16 x 1" LONG, SST
4	4	WR50167	WASHER, LOCK, 3/8", SST
3	4	107220	WASHER, FENDER, 13/32" ID x 1-1/2" OD
2	1	111764	UNISTAND25 EQUIPMENT STAND ASSY
1A	1	-	UPPER STEAMCRAFT®21CET8 STEAMER
1	1	-	LOWER STEAMCRAFT®21CET8 STEAMER

*SUPPLIED WITH OR PART OF STEAMCRAFT® STEAMER

NOTES

- 1) SUPPLIED WITH STEAMER, NOT PART OF KIT
- 2) ITEM 26 NOT SHOWN, SEE FIGURE 3 ON PAGE 4
- 3) FOR COMPLETE STEAMER INSTALLATION INSTRUCTIONS, SEE INSTALLATION MANUAL PROVIDED WITH STEAMER, P/N 260API

FIGURE 4
ASSEMBLY DIAGRAM FOR TWO STEAMCRAFT® 21CET8 STEAMERS
MOUNTED ON A UNISTAND25 EQUIPMENT STAND

Installation Instructions

SteamChef™ Direct Stack Mounting Kit for two SteamChef™ 22CET3.1 Steamers mounted on a Unistand25 Equipment Stand

The installation of Cleveland Range steamers on the Unistand25 Equipment Stand should only be performed by Cleveland Range authorized technicians. Read the entire installation procedure before beginning.

This kit is intended for mounting (2) SteamChef™ 22CET3.1 steamers on a Unistand25 Equipment Stand. Do not mount SteamCraft® 21CET8 steamers with this kit. Use kit P/N 107166 to mount SteamCraft® 21CET8 steamers.

SteamChef™ Mounting Kit (P/N 111771 Parts List)

ITEM ON FIGURE 5	QUANTITY	PART NUMBER	DESCRIPTION
26	2	05253*	ELBOW, STREET, 90, 1/2", BRASS
25	1	085111800	HOSE, WHITE, EPDM, 3/4" ID X 18" LONG
24	1	14324	NIPPLE, CLOSE, 1/2" NPT, BRASS
23	2	110998	HOSE ASSEMBLY, GHT(F) X 2' LONG, NSF
22	4	111704	FITTING, 1/2" NPT(M) X 3/4" GHT(M) BRASS
21	3	20229	TEE, 1/2" NPT, BRASS
20	2	110997	FITTING, 1/2" NPT(M) X 3/4" GHT(F) BRASS
19	4	110987*	STRAINER WASHER, GARDEN HOSE
18	2	102018	CLAMP, HOSE, WORM DRIVE, 1-1/2" – 2"
17	1	1109841300	HOSE, BLACK, EPDM, 1-1/2" ID X 13" LONG
16	2	110985	FITTING, 1-1/2" HOSE X 1-1/2" NPT(M), ZP
15	2	03204	CLAMP, HOSE, WORM DRIVE, .812-1.50 DIA
14	2	06241	FTG, HOSE BARB, 3/4" X 1/2" NPT, BRASS
13	1	05238	ELBOW, 1-1/2" NPT, BLACK
12	1	20221	TEE, 1-1/2" NPT, BLACK
11	2	02579	BUSHING, HEX, 1-1/4" NPT X 1-1/2" NPT BLK
10	2	14496	NIPPLE, 1-1/4" NPT X 2-1/2" LONG, BLK, TBE
9	2	14665	NUT, HEX, UNLOCK, 1/4-20, SST
8	2	23116	WASHER, FLAT, 9/32" ID X 5/8" OD, SST
7	1	110849	RETAINER, STACKING SPACER
6	2	110843	SIDE SUPPORT, STACKING SPACER
5	2	111012	SCREW, HEX HEAD, 1/2-13 X 3/4" LONG, SST
4	2	23153	WASHER, LOCK, 1/2", SST
3	2	111013	WASHER, FENDER, 17/32" ID X 1.50" OD
2	1	111764	UNISTAND25 EQUIPMENT STAND ASSY
1	2	-	STEAMCHEF™ 22CET3A STEAMER

*Supplied with or part of SteamChef™ steamer.

1333 East 179th Street
Cleveland, Ohio 44110
Phone: (216) - 481 - 4900
Fax: (216) - 481 - 3782
www.clevelandrange.com



In addition to knowledge of this procedure, the installer must be familiar with the instructions supplied with each SteamChef™ Steamer. These instructions are Cleveland Range P/N 22CET-OPM.

IMPORTANT: Use a suitable pipe thread sealant or Teflon tape on all NPT threaded connections.

IMPORTANT: Use a suitable plain washer or strainer washer at all Garden Hose threaded connections.

IMPORTANT: DO NOT USE PIPE THREAD SEALANT OR TEFLON TAPE ON GARDEN HOSE THREADED CONNECTIONS.

1. Position the stand in the selected location so that the feet with round mounting pads are at the rear.
2. Level the stand front-to-back and side-to-side with the adjustable feet.
3. Set lower steamer directly on stand as shown in Figure 5 on page 5.
 - The 4-inch legs provided with steamer are not used when installing SteamChef™ steamers on a stand.
4. Align the steamer so that the rear mounting bolts will come up through the holes marked "A" in Figure 1.

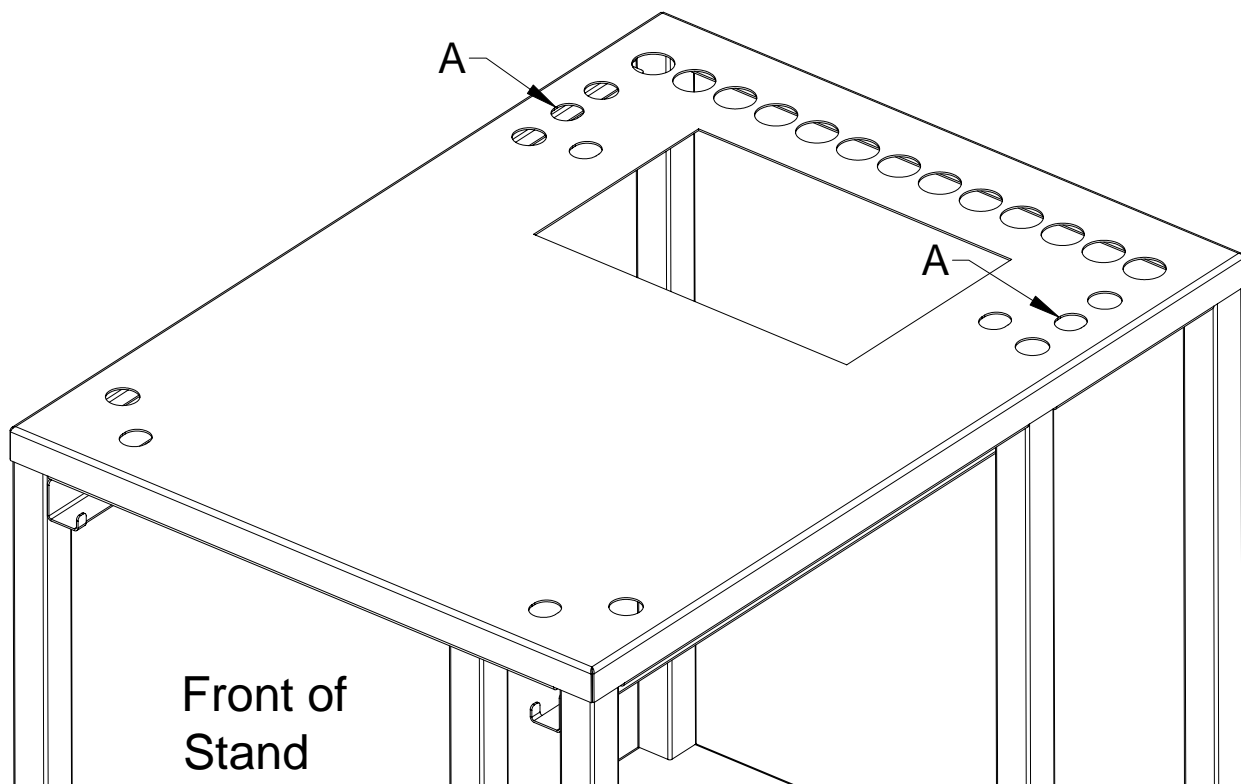

Figure 1 SteamChef™ Mounting Holes

5. Secure the lower steamer to the stand using the two (2) sets of bolts and washers provided as shown in Figure 5 (Items 3, 4, and 5).
6. Remove the right side panel and seal any gaps between steamer and stand with a suitable RTV Sealant (not provided) as shown in Figure 4.
7. Install the stacking spacer side supports and retainer.
 - a. Set studded side supports (Figure 5, Item 6) on top of lower unit. (See Figure 2.)
 - b. The end of the support with nearer stud must be toward front of steamer.
 - c. Set the retainer (Figure 5, Item 7) over the side supports.
 - The side support studs will come up through the corresponding holes in the retainer
 - The lower edges of the retainer will extend over the top of the steamer. (See Figure 3.)

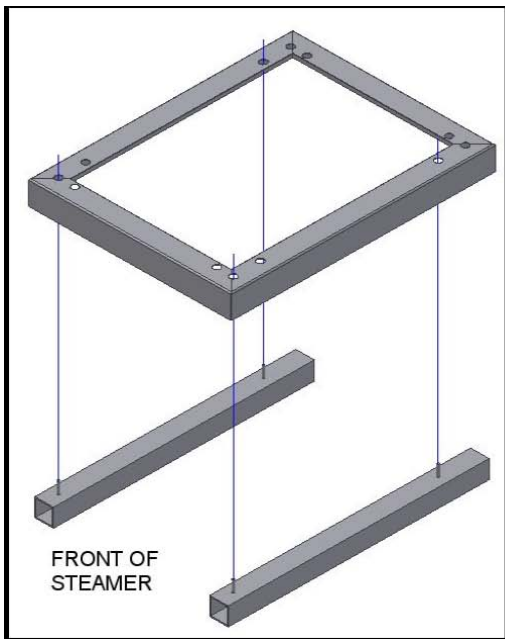

Figure 2

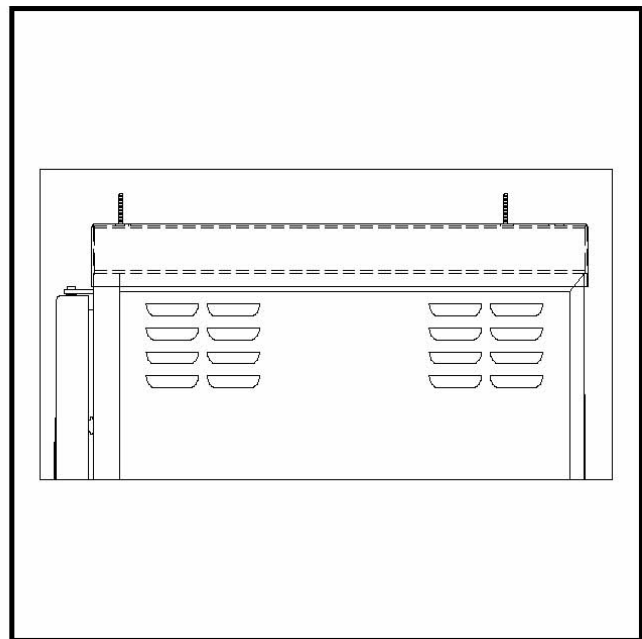

Figure 3

Positioning the Stacking Spacer Installed Stacking Spacer

8. Do NOT screw the 4" legs into the upper steamer.
9. Remove the side panels from the upper steamer.
10. Apply a bead of RTV sealant around the entire top perimeter of the stacking spacer retainer. (See Figure 4.)
11. Place upper steamer on top of retainer so that the 1/4-20 studs go through the 1/2" nuts that legs would have screwed into.

12. Secure the upper steamer to the stacking spacer using two sets of the 1/4" flat washers and locknuts (Items 8 and 9 in Figure 5) installed on the front studs.
13. Attach drain fittings as shown in Figure 5 (Items 10 -16).
 - Use a suitable pipe thread sealant or Teflon tape (not provided) on all threaded connections.
 - Use a suitable plain washer or strainer washer at all Garden Hose threaded connections.
 - **DO NOT USE PIPE THREAD SEALANT OR TEFLON TAPE ON GARDEN HOSE THREADED CONNECTIONS!**
14. Check the length of the drain hose (Figure 5, Item 17) and shorten if necessary.
15. Place the worm drive clamps (Figure 5, Item 18) over the hose and push the hose onto the upper hose fitting.
16. Slightly rotate the lower tee and hose fitting counter-clockwise until the lower end of the hose can start onto the fitting.
17. Slide the hose fully onto the fitting by rotating the tee and fitting back to their original vertical position.
18. Secure the hose to the fittings with the worm drive clamps.
19. Attach the inlet water trains for the reservoir and the condenser as shown in Figure 5 (Items 19 – 23).
 - Each SteamChef™ steamer is supplied with strainer washers (Figure 5, Item 19) for use on the water inlets. **THESE STRAINER WASHERS MUST BE USED ON THE STEAMER WATER INLET CONNECTIONS.**
 - Use a suitable pipe thread sealant or Teflon tape (not provided) on all NPT threaded connections.
 - Use a suitable plain washer or strainer washer at all Garden Hose threaded connections.
 - **DO NOT USE PIPE THREAD SEALANT OR TEFLON TAPE ON GARDEN HOSE THREADED CONNECTIONS!**
20. After the RTV sealant has set, replace the side panels.
 - Do not seal the right side panels to the steamers or the stand.
 - The right side panels must be easily removable for service access.
21. The stand must be anchored to the floor through the holes in the round mounting pads on the rear feet.
22. Complete installation of the steamers as outlined in the SteamChef™ Operators Manual, P/N 22CET-OPM.

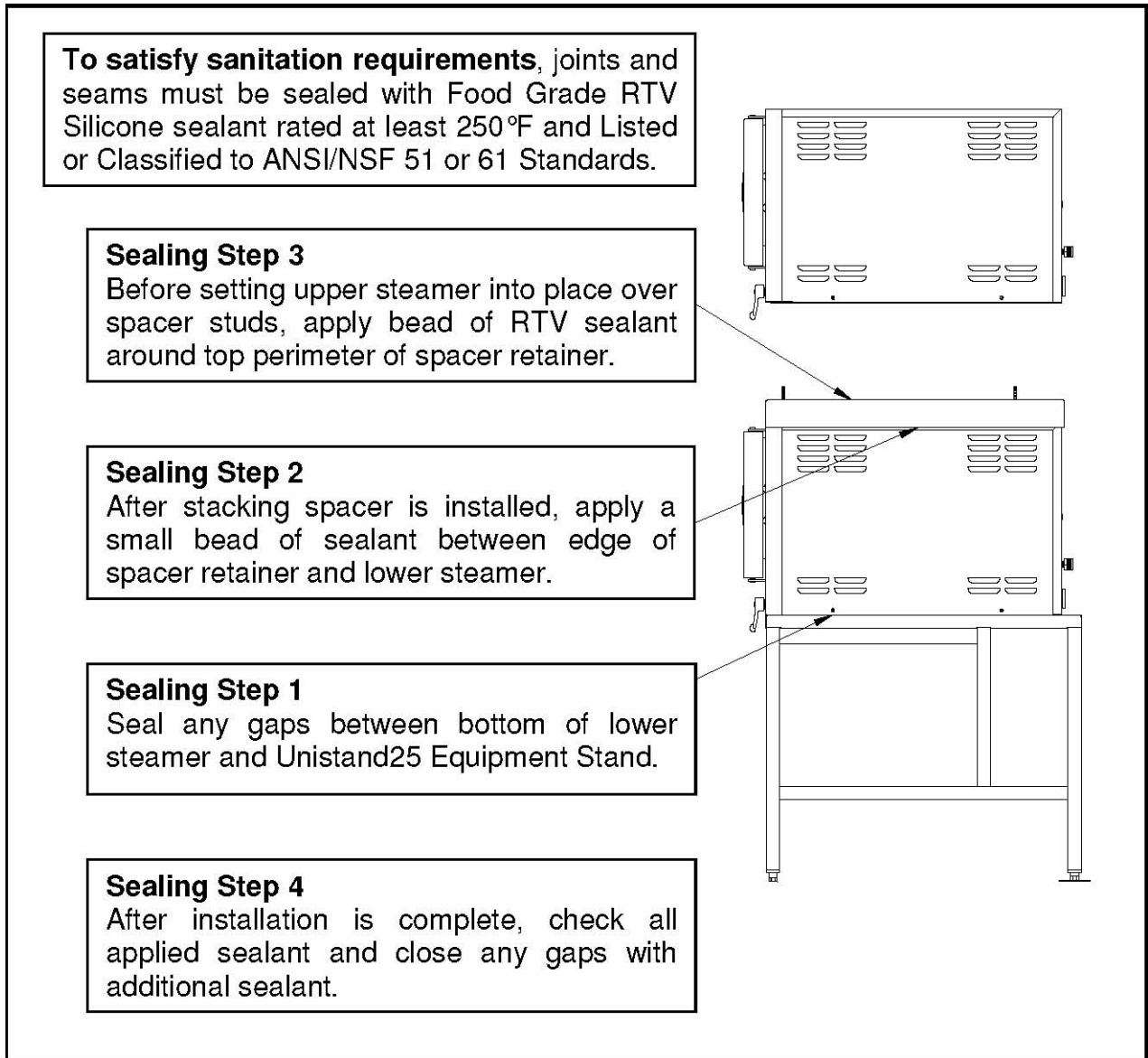
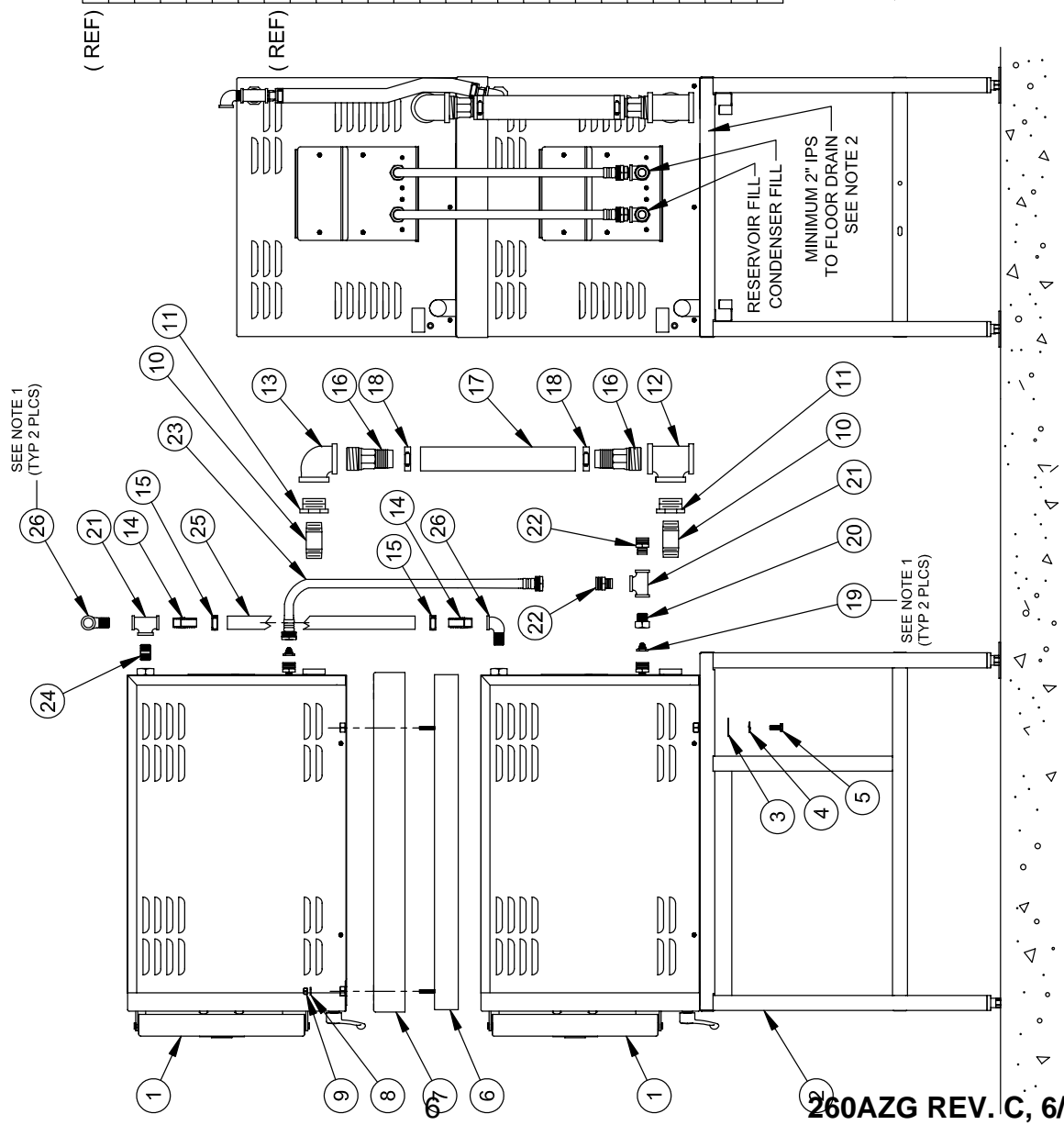

Figure 4
Sealing Requirements



ITEM	QTY	PART NO.	DESCRIPTION
26	2	05253*	ELBOW, STREET 90, 1/2", BRASS
25	1	08511800	HOSE, WHITE, EPDM, 3/4" ID x 18" LONG
24	1	14324	NIPPLE, CLOSE, 1/2" NPT, BRASS
23	2	110998	HOSE ASSEMBLY, GHT (F) x 2' LONG, NSF
22	4	111704	FITTING, 1/2" NPT(M) x 3/4" GHT(M), BRASS
21	3	20229	TEE, 1/2" NPT, BRASS
20	2	110997	FITTING, 1/2" NPT (M) x 3/4" GHT (F), BRASS
19	4	110987*	STRAINER WASHER, GARDEN HOSE
18	2	102018	CLAMP, HOSE, WORM DRIVE, 1-1/2" - 2"
17	1	1109841300	HOSE, BLACK, EPDM, 1-1/2" ID x 13" LONG
16	2	110985	FITTING, 1-1/2" HOSE x 1-1/2" NPT (M), ZP
15	2	03204	CLAMP, HOSE, WORM DRIVE, .812-1.50 DIA
14	2	06241	FTG. HOSE BARB, 3/4" X 1/2" NPT, BRASS
13	1	05238	ELBOW, 1-1/2" NPT, BLACK
12	1	20221	TEE, 1-1/2" NPT, BLACK
11	2	02579	BUSHING, HEX, 1-1/4" NPT x 1-1/2" NPT, BLK
10	2	14496	NIPPLE, 1-1/4" NPT x 2-1/2" LONG, BLK, TBE
9	2	14665	NUT, HEX, NYLOCK, 1/4-20, SST
8	2	23116	WASHER, FLAT, 9/32" ID x 5/8" OD, SST
7	1	110849	RETAINER, STACKING SPACER
6	2	110843	SIDE SUPPORT, STACKING SPACER
5	2	111012	SCREW, HEX HEAD, 1/2-13 x 3/4" LONG, SST
4	2	23153	WASHER, LOCK, 1/2", SST
3	2	111013	WASHER, FENDER, 17/32" ID x 1.50" OD
2	1	111764	UNISTAND25 EQUIPMENT STAND ASSY
1	2	-	STEAMCHEF™ 22CET3A STEAMER

*SUPPLIED WITH OR PART OF STEAMCHEF™ STEAMER

NOTES

- 1) SUPPLIED WITH STEAMER, NOT PART OF KIT
- 2) FOR COMPLETE STEAMER INSTALLATION INSTRUCTIONS, SEE MANUAL PROVIDED WITH STEAMER, P/N 22CET-OPM

FIGURE 5

ASSEMBLY DIAGRAM FOR TWO STEAMCHEF™ 22CET3.1A STEAMERS MOUNTED ON A UNISTAND25 EQUIPMENT STAND