

TURBOJET II CHILL TANK

Project _____
 Item _____
 Quantity _____
 FCSI Section 11400 _____
 Approved _____
 Date _____

Models

- HBC200



Model shown HBC200

Standard Features

- Rated capacities for 200 gallons or up to 1700 lbs. of product
- Solid state controls mounted in stainless steel 4X rated enclosures
- Heavy duty stainless steel tank, type 304 construction with adjustable legs
- Rounded internal tank corners for efficient cooling and easy cleaning
- Fully insulated tank with heavy duty stainless steel removable panels
- Automatic water fill and water level controls with over flow protection
- Built-in 5 Hp circulating pump for optimum rapid cooling.
- High efficiency shell and tube heat-exchanger for faster product cooling
- All plumbing connection supplied with line strainers
- Heavy duty stainless steel gas spring assisted lockable cover.
- Accepted for use in U.S.D.A. Inspected Facilities
- NSF/ANSI Standard 169 approved

Short Form Specifications

Shall be Cleveland Model HBC200 Chill Tank, rated capacity of up to 1,700 lbs., fully insulated, Stainless steel tank and circulation pump for optimum water distribution, Solid state controls enclosed in UL rated, Stainless steel type NEMA 4X enclosure with automatic adjustable temperature control, Lockable gas spring assist cover, Direct expansion refrigerant in-line heat exchanger for efficient cooling.

Options & Accessories

- Basket set and dolly
- Hoists for loading and unloading product baskets
- Air Power Vacuum Clipper
- Remote mounted 30 Hp Air-cooled condensing unit
- Remote mounted 30 Hp water cooled condensing unit
- Digital Time/Temperature Recorder with USB Port (DDR)

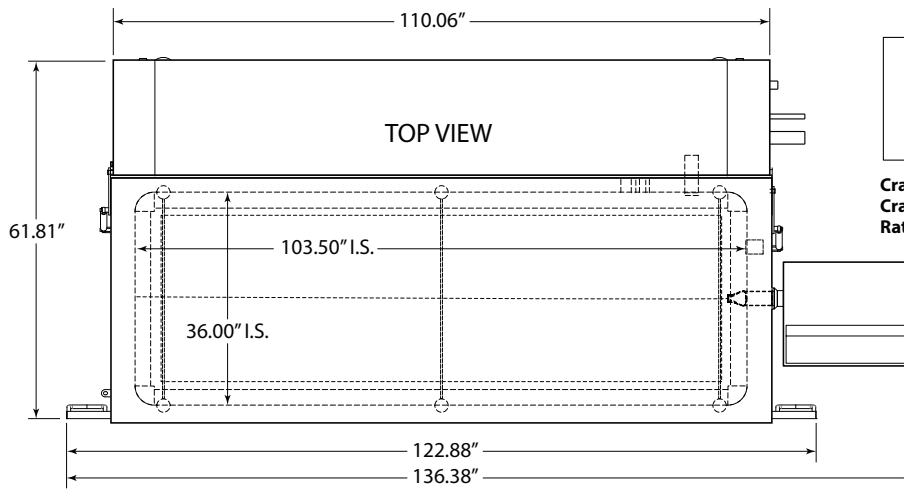

MINIMUM CLEARANCE	
REAR	24"
RIGHT SIDE	12"
LEFT SIDE	8"

Crate Size: 143"L x 67"W x 66"H
Crate Weight: 3,200 lbs
Rate of Class: 85

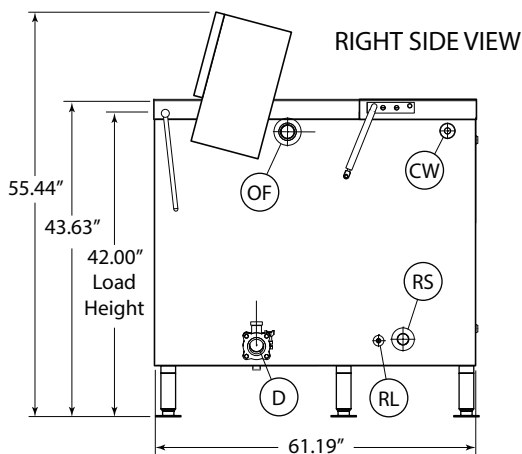
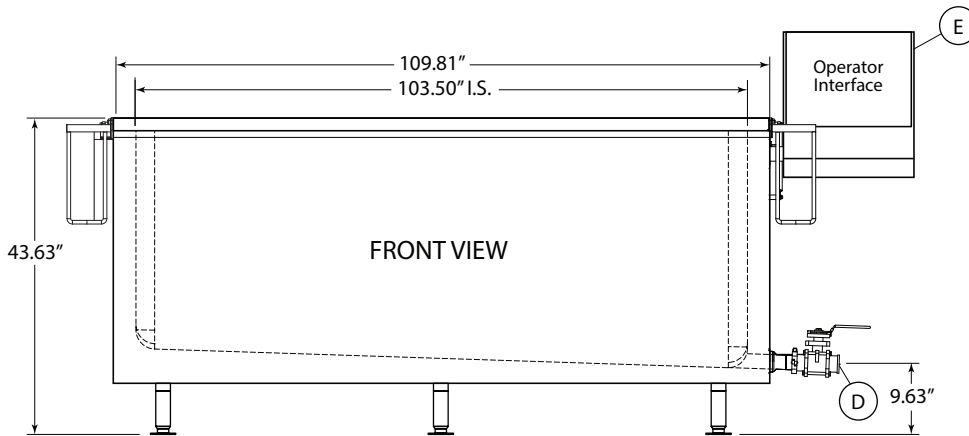

- (CW)** Cold Potable Water: 3/4" NPT, 180 Gal. Capacity
- (D)** Drain: 2" T-C, 75 GPM
- (P)** Pump: 5 HP, 3 Phase, 3450 RPM
- (RL)** Refrigerant Liquid Line: 1 1/8" ODF
- (RS)** Refrigerant Suction Line: 2 1/8" ODF, 210,000 BTU/HR @+25° FSST, @95°F Ambient
- (OF)** Overflow: 1 1/2" FPT
- (E)** Electrical: 3PH, 60CYC, 208V, 25 Full Load Amps
 3PH, 60CYC, 230V, 22 Full Load Amps
 3PH, 60CYC, 480V, 11 Full Load Amps
 Connections per Local Codes.
 Disconnect supplied by others
 (customer to specify requirements)

Cleveland Range reserves right of design improvement or modification, as warranted.

(NOT TO SCALE)