

#	DESCRIPTION	DATE	APPROVED
U	MATERIAL WAS ES15, NOW ES40 OR EI63	07/18/2019	SZOHORI
U	FA05002-55 MAN. PART# 2-322V708-FDA WAS ASS598-322	07/30/2019	FGUIRGUIS
U	FA05002-56 MAN. PART# 2-332V708-FDA WAS ASS598-332		

PART #	REV.	MATERIAL	MANUFACTURER #	I.D.	O.D.	W.	TOL. ±
FA05002-1	A	VITON	A-214	1"	1 1/4"	1/8"	.010
FA05002-2	A	FDA BUNA-N	2-164	6 1/4"	6 7/16"	7/64"	.040
FA05002-3	A	FDA BUNA-N	A-222	1 1/2"	1 3/4"	1/8"	.015
FA05002-4	A	BUNA-N	A-116	3/4"	15/16"	3/32"	.009
FA05002-5	A	FDA BUNA-N	A-434	5 5/8"	6 1/8"	1/4"	.037
FA05002-6	A	VITON	A-218	1 1/4"	1 1/2"	1/8"	.012
FA05002-7	A	BUNA-N	A-128	1 1/2"	1 11/16"	3/32"	.012
FA05002-8**	B	BUNA-N	4-325	1 1/2"	1 7/8"	3/16"	.015
FA05002-9	A	EPDM-ES0	A-115	1 1/16"	7/8"	3/32"	.009
FA05002-10	A	EPDM-ES0	A-215	1 1/16"	1 5/16"	1/8"	.010
FA05002-11	A	EPDM-ES0	A-358	5 5/8"	6"	3/16"	.037
FA05002-12	A	EPDM-ES0	A-110	3/8"	9/16"	3/32"	.005
FA05002-13	A	EPDM-ES0	A-136	2"	2 3/16"	3/32"	.005
FA05002-14	A	EPDM-ES0	A-004	5/64"	13/64"	1/16"	.070
FA05002-15	A	EPDM-ES0	A-112	1/2"	11/16"	3/32"	.017
FA05002-16	A	EPDM-ES15	A-113	7/16"	3/4"	3/32"	.005
FA05002-17	A	EPDM-ES15	A-019	13/16"	15/16"	1/16"	.009
FA05002-18	A	EPDM-ES0	A-011	5/16"	7/16"	1/16"	.005
FA05002-19	B	EPDM-ES40 OR EI63	A-016	5/8"	3/4"	1/16"	.009
FA05002-20	A	BUNA-N	A-029	1 1/2"	1 5/8"	1/16"	.013
FA05002-21	A	BUNA-N	A-225	1 7/8"	2 1/8"	1/8"	.018
FA05002-22	A	BUNA-N	A-152	3 1/4"	3 7/16"	3/32"	.024
FA05002-23	B	BEYOND BACKSULATED SILICONE	2-120T/ES	1"	1 3/16"	3/32"	.010
FA05002-24	A	BUNA-N	A-111	7/16"	5/8"	3/32"	.005
FA05002-25	A	VITON	A-226	2"	2 1/4"	1/8"	.018
FA05002-26	B	VITON	A-434	5 5/8"	6 1/8"	1/4"	.037
FA05002-27	A	VITON	A-224	1 3/4"	2"	1/8"	.015
FA05002-28	A	EPDM-ES0	A-008	3/16"	5/16"	1/16"	.005
FA05002-29	B	EPDM-ES40 OR EI63	A-114	5/8"	13/16"	3/32"	.009
FA05002-30	A	EPDM-ES0	A-033	2"	2 1/8"	1/16"	.018
FA05002-31	A	BUNA-N	A-427	4 3/4"	5 1/4"	1/4"	.033
FA05002-32	A	BUNA-N	A-425	4 1/2"	5"	1/4"	.033
FA05002-33	B	EPDM-ES40 OR EI63	A-021	15/16"	1 1/16"	1/16"	.009
FA05002-34	A	EPDM-ES0	A-012	3/8"	1/2"	1/16"	.005
FA05002-35	A	VITON	A-018	3/4"	7/8"	1/16"	.009
FA05002-36	A	EPDM-ES40	A-017	11/16"	13/16"	1/16"	.009
FA05002-37	A	VITON	A-117	13/16"	1"	3/32"	.010
FA05002-38	A	BUNA-N	A-210	3/4"	1"	1/8"	.010
FA05002-39	A	BUNA-N	A-006	1/8"	1/4"	1/16"	.0005
FA05002-40	A	VITON	A-123	1 3/16"	1 3/8"	3/32"	.012
FA05002-41	A	VITON	A-316	7/8"	1 1/4"	3/16"	.010
FA05002-42	A	EPDM-ES609-70	2-212	7/8"	1 1/8"	1/8"	.010
FA05002-43	A	VITON	2-216	1 1/8"	1 3/8"	1/8"	.0004
FA05002-44	A	EPDM-ES92-75	2-349	4 1/2"	4 7/8"	3/16"	.0005
FA05002-45	A	VITON	A-228	2 1/4"	2 1/2"	1/8"	.018
FA05002-46	B	EPDM-ES40 OR EI63	A-123	1 3/16"	1 3/8"	3/32"	.012

THIS DRAWING IS THE PROPERTY OF CLEVELAND RANGE LTD. IT IS TO BE USED ONLY FOR THE PURPOSES SPECIFIED HEREIN. ANY REUSE OR MODIFICATION WITHOUT THE WRITTEN PERMISSION OF CLEVELAND RANGE LTD. IS STRICTLY PROHIBITED.

CLEVELAND RANGE LTD.
8251 KEELE STREET, CONCORD, ONTARIO, CANADA

O-RING
FA05002

DO NOT SCALE PRINTED DRAWING

DATE: 2/7/2007

SIZE: B

DRAWING NO.: FA05002

SHEET 1 OF 1

REV: U

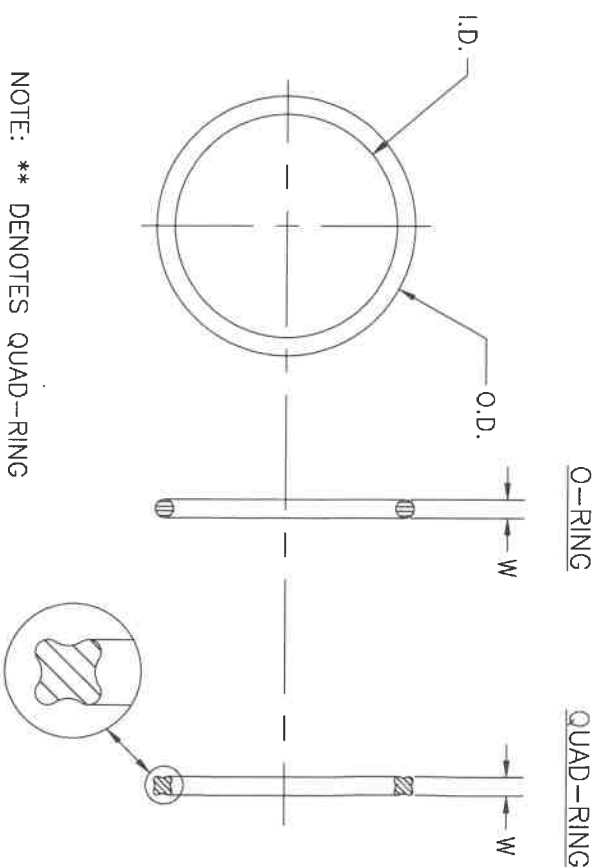

PART #	REV.	MATERIAL	MANUFACTURER #	I.D.	O.D.	W.	TOL. ±
FA05002-47	A	BUNA-N	2-136	2"	2 3/16"	3/32"	.017
FA05002-48	A	REF. J.C. PARDO, PART # SE30RINGS00046	2-010	REF. 2 1/2"	REF. 2 7/8"	0.210	.010
FA05002-50	A	BUNA-N	2-010	1/4"	3/8"	1/16"	.005
FA05002-51	A	FDA BUNA-N	A-331	2 1/4"	2 5/8"	3/16"	.018
FA05002-52	A	FDA BUNA-N	A-038	2 5/8"	2 3/4"	1/16"	.020
FA05002-53	A	FDA BUNA-N	A-151	3	3 3/16"	3/32"	.024
FA05002-54	A	BUNA-N	2-020	7/8"	1	1/16"	.009
FA05002-55	B	FDA VITON FLUOROELASTOMER	2-332V708-FDA	1 1/4"	1 5/8"	3/16"	.012
FA05002-56	B	FDA VITON FLUOROELASTOMER	2-332V708-FDA	2 3/8"	2 3/4"	3/16"	.012
FA05002-57	A	FDA BUNA-N	9555K14	27/64"	9/16"	1/16"	.012