

BASKETS AND BASKET SYSTEMS

USED TO COOK PASTA AND OTHER ITEMS
IN CLEVELAND KETTLES

Project _____
Item _____
Quantity _____
FCSI Section 11400 _____
Approved _____
Date _____

Models

- SEE BACK PAGE FOR MODEL #S

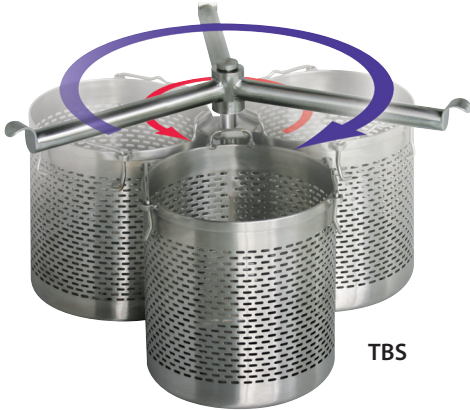

Standard Features

- Perforated Baskets and Tri Basket Support are made of 18 gauge, 304 grade stainless steel, #4 finish
- Baskets come with retractable handles for ease of use
- TBS Basket Systems come complete with three baskets and one Tri Basket Support
- Baskets rotate around Tri Basket Support allowing each Basket to be accessed from the front of kettle

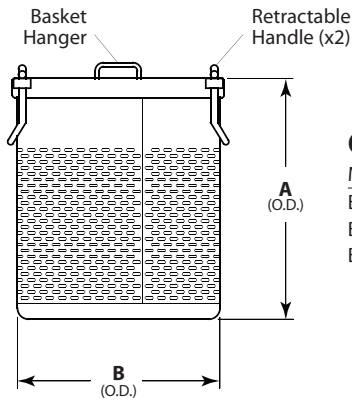

Cooking Baskets

Model #	Kettle Type	A	B
BS3	Cleveland 3 Gallon	9.38" (238mm)	8.50" (216mm)
BS6	Cleveland 6 Gallon	9.25" (235mm)	11.00" (279mm)
BS12	Cleveland 12 Gallon	11.50" (292mm)	14.50" (364mm)

Basket Systems

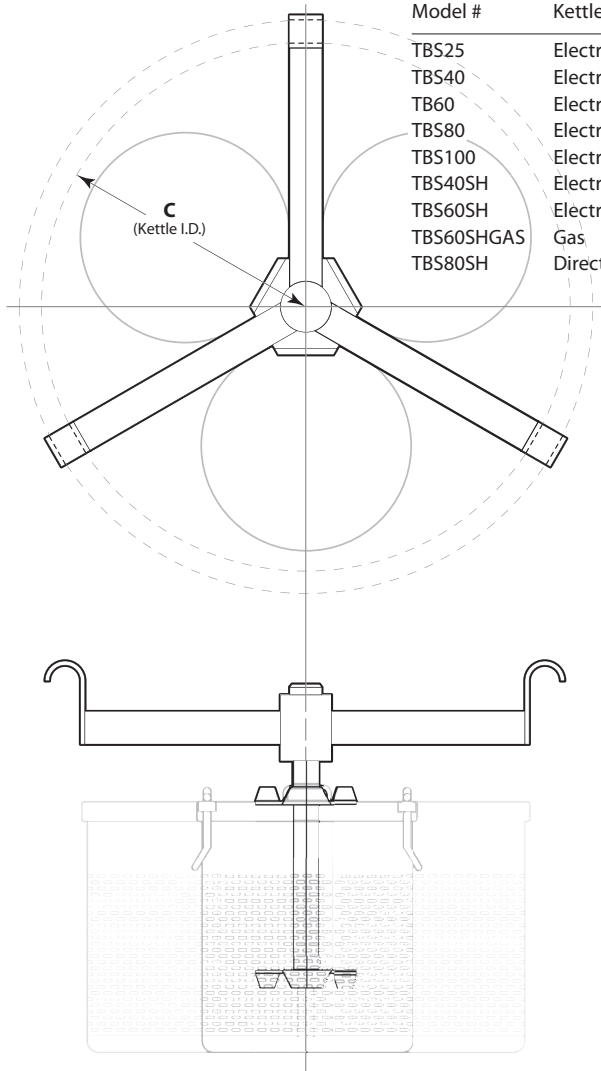

Model #	Kettle Type	US gallons	Baskets Included	C (Kettle I.D.)
TBS25	Electric & Direct Steam	20 & 25	3 x BS3	21.00" (534mm)
TBS40	Electric, Direct Steam & Gas	40	3 x BS6	26.00" (661mm)
TB60	Electric, Direct Steam & Gas	60	3 x BS6	29.50" (750mm)
TBS80	Electric, Direct Steam & Gas	80	3 x BS6	33.00" (839mm)
TBS100	Electric, Direct Steam & Gas	100	3 x BS12	35.50" (902mm)
TBS40SH	Electric, Direct Steam & Gas	40SH	3 x BS6	29.50" (750mm)
TBS60SH	Electric & Direct Steam	60SH	3 x BS6	33.00" (839mm)
TBS60SHGAS	Gas	60SH	3 x BS6	35.50" (902mm)
TBS80SH	Direct Steam	80SH	3 x BS6	35.50" (902mm)

NOTES:

Cleveland Range reserves right of design improvement or modification, as warranted.
 Many regional, state and local codes exist and it is the responsibility of the owner and installer to comply with the codes.
 Installation of backflow preventers, vacuum breakers and other specific code requirements is the responsibility of the owner and installer.
 Cleveland Range equipment is built to comply with applicable standards for manufacturers. Included among those approval agencies are U.L., A.G.A., NSF, ASME/N.Bd., CSA, CGA, ETL and others.

(NOT TO SCALE)