

**COOK/CHILL  
COMBINATION 120 Gal. TUMBLE  
CHILLER COOK TANK, 200 Gal GLYCOL  
RESERVOIR, AND 30 TON WATER  
COOLED CHILLER**

**INSTALLATION, OPERATION, MAINTENANCE,  
AND REPLACEMENT PARTS MANUAL**

**MODEL# TCCT-120-CC  
SERIAL# WWWW  
MODEL# TJ-100-GHEP  
SERIAL# XXXX  
MODEL# TJ-100-30HP/WC  
SERIAL# ZZZZ**

**By:**

**Manitowoc Ovens & Advanced Cooking  
(Americas) Cleveland Operations**

1333 East 179<sup>th</sup> Street  
Cleveland, Ohio, USA 44110  
Web: [www.ClevelandRange.com](http://www.ClevelandRange.com)  
Email: [Steam@ClevelandRange.com](mailto:Steam@ClevelandRange.com)

## TABLE OF CONTENTS

<b>IMPORTANT SERVICE INFORMATION</b> .....	4
<b>SPECIFICATION SHEETS</b> .....	5
<b>SAFETY PRECAUTIONS</b> .....	6
<b>INSTALLATION</b> .....	7
<b>TCCT-120-CC Utility &amp; Clearance:</b> .....	8
<b>TJ-100-30HP/WC Utility &amp; Clearance:</b> .....	10
<b>Interconnecting/Flow Diagram</b> .....	11
<b>TCCT-120-CC Floor Flange Adjustment:</b> .....	13
<b>OPERATING INSTRUCTIONS:</b> .....	14
<b>DAILY PRE-START UP</b> .....	14
<b>Production Mode</b> .....	15
<b>A. Chiller for Kettle Cooked Foods:</b> .....	15
<b>B. Overnight Cooking Using Meat Probe.</b> .....	17
<b>C. Overnight Cooking To Time and Temperature Without Meat Probe:</b> .....	19
<b>D. Rethermalizing/Cooking In Casing, Such as Eggs &amp; Flaked Potatoes:</b> .....	20
<b>E. Use Soak Cycle with Cook Tank Overnight Cooking:</b> .....	20
<b>POST PRODUCTION &amp; SHUT DOWN</b> .....	22
<b>EMERGENCY OPERATIONS</b> .....	22
<b>CLEANING:</b> .....	23
<b>NAFEM STAINLESS STEEL EQUIPMENT CARE AND CLEANING MANUAL:</b> .....	25
<b>RECOMMENDED PREVENTIVE MAINTENANCE:</b> .....	28
<b>1. TESTING SAFETY RELIEF VALVE</b> .....	28
<b>2. GLYCOL RESERVOIR FLUID:</b> .....	28
<b>3. GENERAL TUMBLE CHILLER COOK TANK COMPONENTS:</b> .....	29
<b>1.2. AIR PRESSURE</b> .....	29
<b>1.3. LEAKS</b> .....	29
<b>1.4. CONTROL PANEL</b> .....	29
<b>4. MONTHLY INSPECTIONS</b> .....	29
<b>MAINTENANCE AND INSPECTION:</b> .....	31
<b>1. See Component Manuals for Maintenance Instructions for pump &amp; motor.</b> 31	
<b>2. See Component Manuals for Maintenance Instructions on these items</b> .....	31
<b>1. Cover Actuator Adjustment and Maintenance</b> .....	32
<b>2. ASCO SOLENOID VALVE</b> .....	33
<b>ELECTRICAL SCHEMATICS:</b> .....	34
<b>Tumble Chiller Cook Tank (208V-3PH-60HZ)</b> .....	34
<b>Tumble Chiller Cook Tank – (continued)</b> .....	35
<b>Tumble Chiller Cook Tank – (continued)</b> .....	36
<b>Tumble Chiller Cook Tank – (continued)</b> .....	37
<b>Fuse Charts, Tumble Chiller Cook Tank</b> .....	38
<b>Glycol Reservoir Schematics (208V-3PH-60HZ)</b> .....	39
<b>Fuse Chart, Glycol Reservoir</b> .....	40
<b>Settings Label, Aquasnap 20 Ton Air Chiller</b> .....	41

<b>REPLACEMENT PARTS DRAWINGS:</b> .....	42
<b>Basic Tumble Chiller Cook Tank (208V)</b> .....	42
<b>Basic Tumble Chiller Cook Tank (208V) – (continued)</b> .....	43
<b>Tumble Chiller Cook Tank, Plumbing (208V)</b> .....	44
<b>Tumble Chiller Cook Tank, Plumbing – (continued)</b> .....	45
<b>Tumble Chiller Cook Tank, Shaft Seal and Bearing</b> .....	46
<b>Tumble Chiller Cook Tank, Control Box, External</b> .....	47
<b>Tumble Chiller Cook Tank, Control Box, Internal (208V)</b> .....	48
<b>Glycol Reservoir - (208V-3PH-60HZ)</b> .....	49
<b>Glycol Reservoir - (208V-3PH-60HZ) – (continued)</b> .....	50
<b>Appendices</b> .....	51
<b>Appendix A: Basic Trouble Shooting Tumble Chiller Cook Tank</b> .....	51
<b>Appendix B: Basic Trouble Shooting Glycol Reservoir</b> .....	52
<b>Appendix C: Basic Trouble Shooting 20 Ton Air Chiller</b> .....	52
<b>Appendix D: Component Data Sheets</b> .....	53
<b>1. Watts Electric Motor Valve</b> .....	53
<b>2. Dwyer Series 673 Pressure Switch</b> .....	59
<b>Appendix E: Component Manuals Supplied in addition to this manual</b> .....	60
<b>Appendix F: Component Programs</b> .....	61
<b>1. Partlow 8000 Dual Pen Chart Recorder Program</b> .....	61
<b>2. C48T Redlion Timer Program</b> .....	63
<b>3. Redlion Temperature Controller Program</b> .....	64
<b>Appendix G: ASME Code Compliance Documents</b> .....	66
<b>Appendix H: SEW Eurodrive Drive Unit</b> .....	67
<b>Appendix I: Factory Inspection and Test Paperwork</b> .....	68

## IMPORTANT SERVICE INFORMATION

### A. MODEL NUMBERS AND SERIAL NUMBERS

CLEVELAND RANGE, LLC ASSIGNS TWO PRODUCT IDENTIFICATION NUMBERS TO EACH UNIT: A MODEL NUMBER AND A SERIAL NUMBER. THE MODEL NUMBER IDENTIFIES THE PRODUCT CHARACTERISTICS. THE SERIAL NUMBER IDENTIFIES THE INDIVIDUAL UNIT.

### B. SERIAL NUMBER RECORD

PLEASE PROVIDE THE MODEL NUMBER AND SERIAL NUMBER WHEN YOU CONTACT CLEVELAND RANGE OR A QUALIFIED CLEVELAND RANGE AUTHORIZED SERVICE REPRESENTATIVE:

SERIAL NUMBER \_\_\_\_\_  
(WRITE THE SERIAL NUMBER OF YOUR TUMBLE CHILLER COOK TANK AND RESERVOIR HERE.)

MODEL NUMBER \_\_\_\_\_  
(WRITE THE MODEL NUMBER OF YOUR TUMBLE CHILLER COOK TANK AND RESERVOIR HERE.)

### C. TECHNICAL ASSISTANCE AND SPARE PARTS

WHEN CALLING CLEVELAND RANGE FOR TECHNICAL ASSISTANCE OR ORDERING OF SPARE PARTS PLEASE INSURE THAT YOU HAVE AT A MINIMUM THE EQUIPMENT SERIAL NUMBER AND PREFERABLE THE MODEL AND WORK SITE THE PIECE OF EQUIPMENT IS LOCATED. THIS INFORMATION WILL REDUCE THE LEAD TIME IN ANSWERING QUESTIONS AND INSURING THAT THE END-USER RECEIVES THE PROPER INFORMATION AND PARTS.

#### NOTE:

- IT IS RECOMMENDED TO HAVE ALL TEMPERATURE SENSORS AND CHART RECORDERS CALIBRATED BY A QUALIFIED THIRD PARTY AT LEAST YEARLY OR WHEN ANY SERVICE/PART REPLACEMENT WORK IS PREFORMED.
- ALL SERVICE MUST BE PERFORMED BY A QUALIFIED CLEVELAND RANGE AUTHORIZED TECHNICIAN.

## SPECIFICATION SHEETS

# COMBINATION TUMBLE CHILLER/ COOK TANK

MODEL:  TCCT-120-CC

### Cleveland Standard Features

- Load capacity for up to; 120 gallons of pumpable product, 750 lbs. of meat
- Combination System greatly reduces valuable kitchen floor space used
- Two pen Chart Recorder for permanent record of time and temperature for both Water Bath and Product
- Selector Switch for Timed or Meat Probe operation
- Programmable Time/Temperature Controls
- Digital Temperature Displays
- Thaw Timer for thawing frozen products before cooking
- Preprogrammed Power Failure Controls for Food Safety
- Steam heated Tank with 50 psi Steam Jacket pressure rating
- Electric driven, perforated, Product Cylinder
- Hinged Cover totally encloses Rotating Inner Cylinder
- Safety Interlock Switch stops cylinder rotation when cover is even slightly lifted
- Two Wire Divider Shelves and one Top Hold-down Rack to keep product in place
- Preset water levels for cooking and cooling
- Shell and Tube Heat Exchanger for fast cooling of products
- Meat Probe for automatic cooking and cooling
- Water Circulating Pump for even Water Bath Temperature
- Manual Override "start/stop" Button
- All electrical and plumbing enclosed in a Stainless Steel Housing
- Accepted for use in U.S.D.A. Inspected Facilities

### Options & Accessories

- Vacuum Packaging unit (Clipper Vac)
- Ice Builders
- Condensing units for Ice Builders
- Ice Water Control Panel
- Steam Boilers
- Spare Meat Probe
- Flow Meter for chilled water loop
- Air Power Vacuum Clipper.



### **Short Form Specifications**

Shall be CLEVELAND, Model: TCCT-120-CC, Combination TUMBLE CHILLER/COOK TANK; 750 lbs. or 120 gallons of product capacity; electric driven perforated Product Cylinder; preset water levels; Meat Probe; Water Circulating Pump; two pen Chart Recorder; programmable Time/Temperature Controls; Digital Temperature Displays; All electrical and plumbing enclosed in a Stainless Steel Housing.

**SAFETY PRECAUTIONS**

***For your safety***

**DANGER**



Keep hands away from moving parts and pinch points.

**IMPORTANT**



Inspect unit daily for proper operation.

**CAUTION**



Surfaces may be extremely hot! Use protective equipment.



Wear protective equipment when discharging hot product.

**SERVICING**



Shut off power at main fuse disconnect prior to servicing.



Ensure kettle is at room temperature and pressure gauge is showing zero or less prior to removing any fittings.

## **INSTALLATION**

### **General**

Installation of the unit must be accomplished by qualified installation personnel working to all applicable local and national codes. Improper installation of product could cause injury or damage. This unit is built to comply with applicable standards for manufacturers. Included among those approval agencies are: UL, NSF, and ASME/National Board. Many local codes exist, and it is the responsibility of the owner/installer to comply with these codes.

### **Inspection**

Before uncrating, visually inspect the unit for evidence of damage during shipping. If damage is noticed, do not unpack the unit, follow shipping damage instructions.

### **Shipping Damage Instructions**

If shipping damage to the unit is discovered or suspected, observe the following guidelines in preparing a shipping damage claim.

- 1.** Write down a description of the damage or the reason for suspecting damage as soon as it is discovered. This will help in filling out the claim forms later. If possible, take a digital picture.
- 2.** As soon as damage is discovered or suspected, notify the carrier that delivered the shipment.
- 3.** Arrange for the carrier's representative to examine the damage.
- 4.** Fill out all carrier claims forms and have the examining carrier sign and date each form.

**TCCT-120-CC Utility & Clearance:**

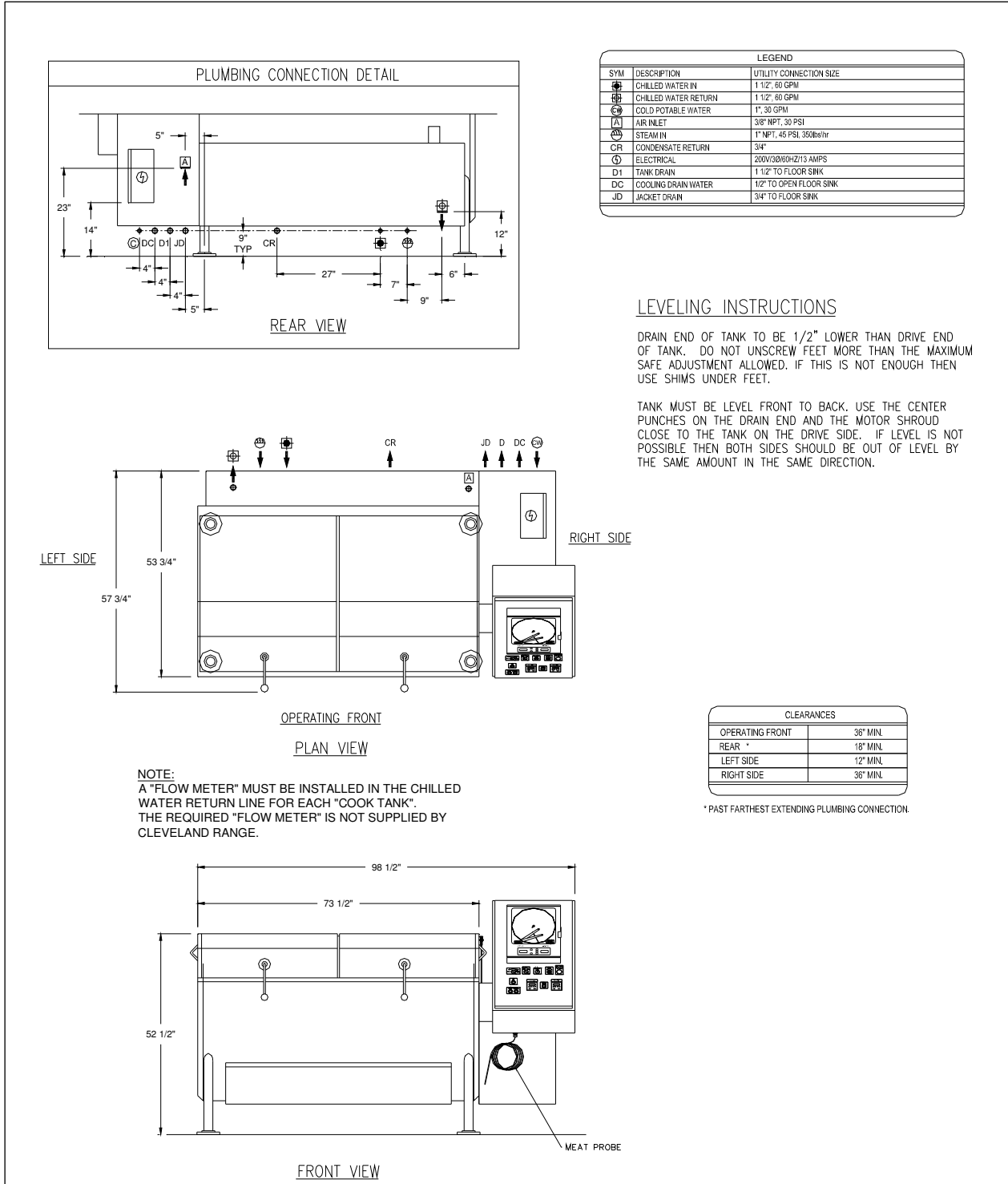

**ITEM# , QTY: 1**  
**TCCT-120-CC, 100 GAL. TUMBLE CHILLER COOK TANK**  
**SERIAL# WWWW**

### TJ-100-GHEP Utility & Clearance:

**INSTALLATION NOTES:**  
 THE GLYCOL RESERVOIR SHOULD BE CLOSE TO LEVEL BEFORE BOLTING TO THE FLOOR. THERE IS NO ADJUSTMENT ON THE FEET.

MOST FLOORS HAVE A PITCH FOR DRAINING. IF THERE IS ANY VOID BETWEEN THE FLANGE AND THE FLOOR; SHIMS MUST BE USED TO FILL THE SPACE

AFTER THE GLYCOL RESERVOIR IS LEVEL, ANCHOR ALL FOOT FLANGES TO THE FLOOR BY USING S.S. OR NON-RUSTING ANCHOR BOLTS

**PIPE SIZING NOTE:**  
 UNIT CONNECTION SIZES ARE NOT TO BE USED AS INTERCONNECTING PIPE SIZES. INTERCONNECTING PIPE SIZES TO BE DETERMINED BY FLOW REQ'S.

**ELECTRICAL NOTES:**  
 1) ELECTRICIAN TO PUNCH HOLE IN JUNCTION BOX AS PER LOCAL CODE FOR POWER CONNECTIONS.

2) CUSTOMER TO SUPPLY IN LINE DISCONNECT FOR CIRCULATING PUMP AS PER LOCAL CODE.

**CIRCULATING PUMP INFORMATION:**  
 1) 3HP 208/460V-3PH-60HZ PUMP.  
 2) 110 FEET HEAD (MAX.) WITH 35 GPM (MIN.) AT TURBOJET.

LEGEND		
SYM	DESCRIPTION	UTILITY CONNECTION SIZE
⊕	GLYCOL SUPPLY	1 1/2" NPT
⊖	GLYCOL RETURN	1 1/2" NPT
⊕	GLYCOL BYPASS	1 1/2" NPT
Ⓢ	ELECTRICAL	208V/3PH/60HZ, MAIN POWER IN

**GLYCOL FLUID USED:  
 30% DOWFROST HD  
 (AN INHIBITED PROPYLENE  
 GLYCOL HEAT TRANSFER  
 FLUID) OR EQUAL**

**FAILURE TO USE THIS FLUID  
 MAY DAMAGE THE SYSTEM**

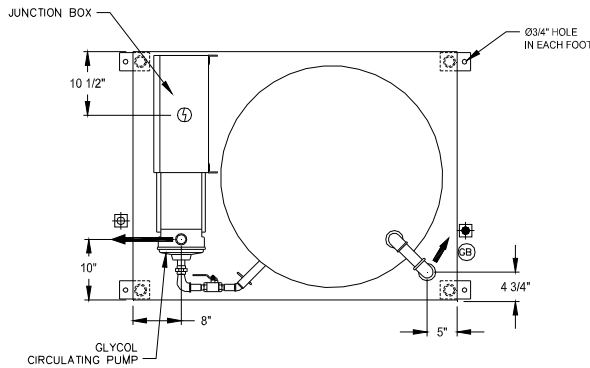

CLEARANCES	
JUNCTION BOX SIDE	36" MIN.
SHUT OT VALVE SIDE	20" MIN.
BLIND SIDES	6" MIN.

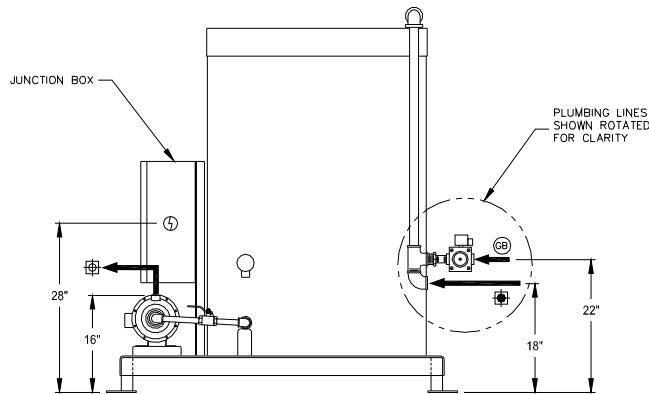
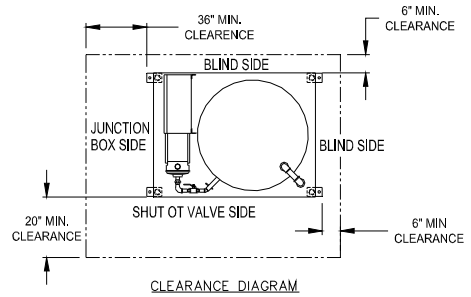

**ITEM# , QTY: 1  
 TJ-100-GHEP, 200 GAL. GLYCOL RESERVOIR HEAT EXCHANGE TANK  
 SERIAL# XXXX**

### TJ-100-30HP/WC Utility & Clearance:

**INSTALLATION NOTES:**  
 CUSTOMER TO SUPPLY AND WIRE DISCONNECT TO UNIT JUNCTION BOX AS PER LOCAL CODE.

DISCONNECT TO BE WALL MOUNTED NEAR UNIT.

WATER COOLED CHILLER CONSIST OF 30TON WATER COOLED CONDENSER WITH HEAT-EXCHANGER.

**PIPE SIZING NOTE:**  
 UNIT CONNECTION SIZES ARE NOT TO BE USED AS INTERCONNECTING PIPE SIZES. INTERCONNECTING PIPE SIZES TO BE DETERMINED BY FLOW REQ'S.

**ELECTRICAL NOTES:**  
 1) ELECTRICIAN TO PUNCH HOLE IN JUNCTION BOX AS PER LOCAL CODE FOR POWER CONNECTIONS.

LEGEND		
SYM	DESCRIPTION	UTILITY CONNECTION SIZE
WC1	GLYCOL TO CR2 ON CHILLER RESERVOIR	2 1/2" NPT
WC2	GLYCOL FROM CR3 ON CHILLER RESERVOIR	2 1/2" NPT
WC3	COOLING WATER SUPPLY	2" NPT
WC4	COOLING WATER RETURN	2" NPT
Ⓧ	ELECTRICAL	208V/3PH/60HZ, MAIN POWER IN

CLEARANCES	
FRONT	12" MIN.
SIDES	36" MIN.
REAR	12" MIN.

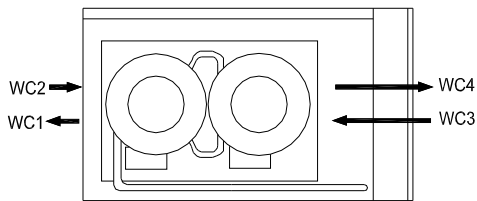

PLAN VIEW

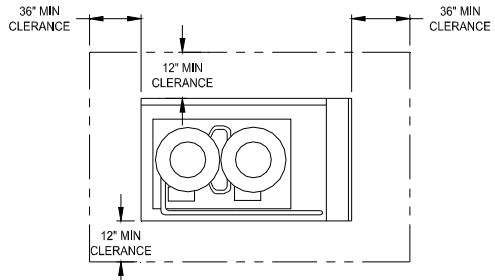

CLEARANCE DIAGRAM

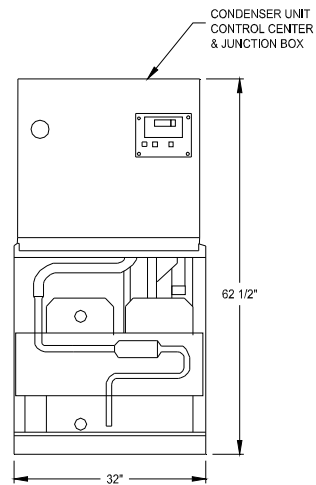
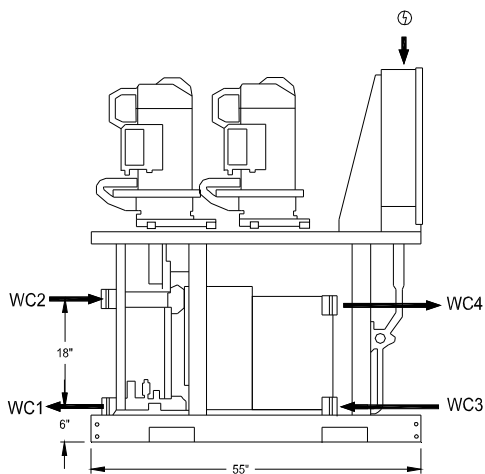

**ITEM# , QTY: 1**  
**TJ-100-C20HP/WC, 30 TON WATER COOLED CONDENSING UNIT**  
**SERIAL# ZZZZ**

## Interconnecting/Flow Diagram

**INSTALLATION NOTES:**  
 CUSTOMER TO SUPPLY AND WIRE DISCONNECT TO UNIT JUNCTION BOX AS PER LOCAL CODE.

DISCONNECT TO BE WALL MOUNTED NEAR UNIT.

**PIPE SIZING NOTE:**  
 UNIT CONNECTION SIZES ARE NOT TO BE USED AS INTERCONNECTING PIPE SIZES. INTERCONNECTING PIPE SIZES TO BE DETERMINED BY FLOW REQ'S.

**ELECTRICAL NOTES:**  
 1) ELECTRICIAN TO PUNCH HOLE IN JUNCTION BOX AS PER LOCAL CODE FOR POWER CONNECTIONS.

LEGEND		
SYM	DESCRIPTION	UTILITY CONNECTION SIZE
⊕	GLYCOL RETURN	SEE UNIT SPEC. SHEET
⊕	GLYCOL SUPPLY	SEE UNIT SPEC. SHEET
⊕	GLYCOL BYPASS	SEE UNIT SPEC. SHEET

**GLYCOL FLUID USED:  
 30% DOWFROST HD  
 (AN INHIBITED PROPYLENE  
 GLYCOL HEAT TRANSFER  
 FLUID) OR EQUAL**

**FAILURE TO USE THIS FLUID  
 MAY DAMAGE THE SYSTEM**

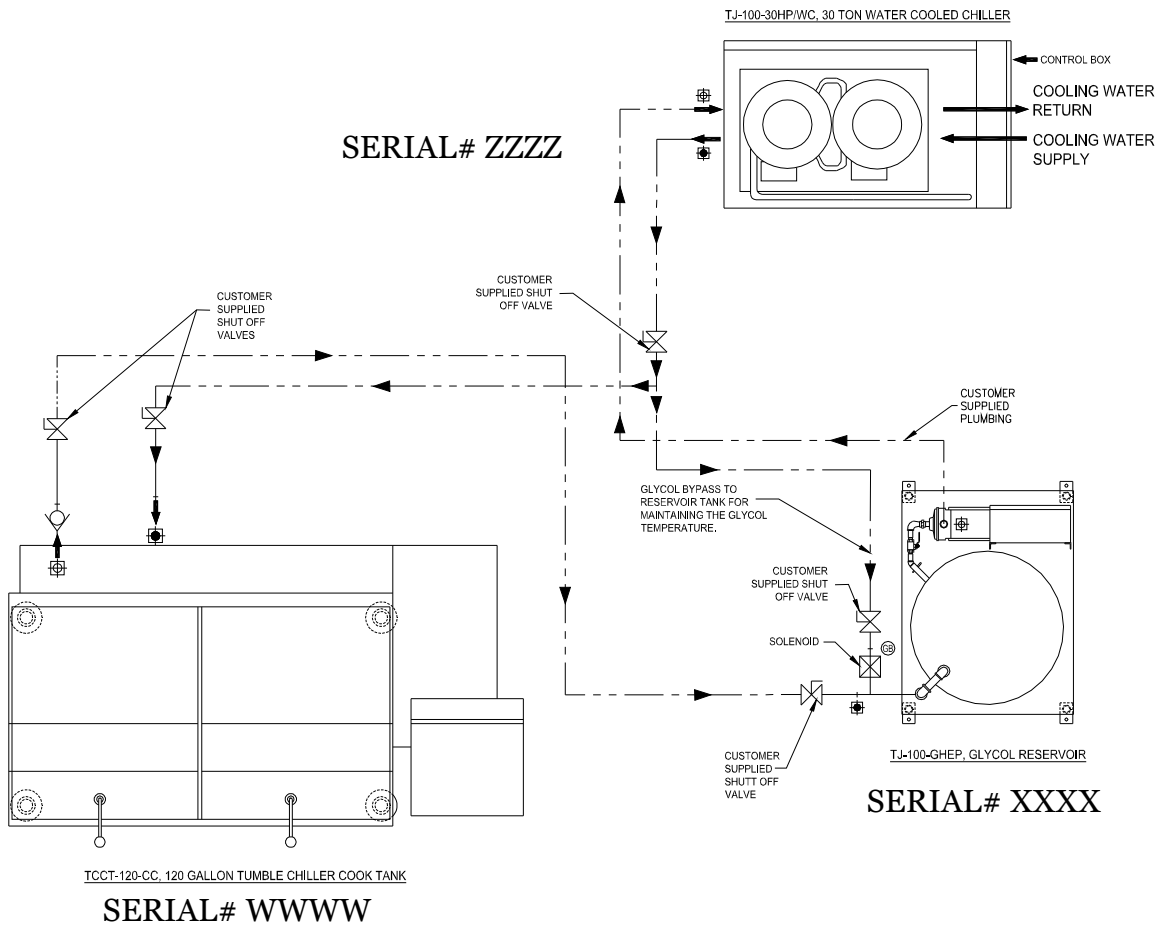

**TCCT-120-CC, TJ-100-GHWP, and TJ-100-C20HP/AC: 20  
 INNER CONNECTING FLOW DIAGRAM**

**WARNING** – IT IS **IMPERATIVE** THAT THE TUMBLE CHILLER/COOK TANK BE LEVEL FRONT TO BACK AND THAT THE DRIVE MOTOR END OF THE TANK IS 1/2” LOWER THAN THE IDLER END BEFORE BOLTING TO THE FLOOR. THIS WILL PREVENT ANY MISALIGNMENT OF THE TUMBLE CHILLER/COOK TANK BASKET, PREVENT DEFLECTION OF THE DRIVE SHAFT DURING OPERATION, AND INSURE THE TANK WILL DRAIN PROPERLY.

1. WHEN REMOVING THE TUMBLE CHILLER/COOK TANK FROM THE SKID, HANDLE WITH CARE TO PREVENT SCRATCHING OR ANY OTHER DAMAGE TO THE EQUIPMENT.
2. LEVELING INSTRUCTIONS:
  - a. FIRST – RAISE THE FLANGES ON ALL 4 LEGS OF THE TUMBLE CHILLER/COOK TANK.
  - b. SECOND – LOWER THE TUMBLE CHILLER/COOK TANK TO THE FLOOR AND START THE LEVELING PROCESS. (SEE STEPS “C & D” FOR INSTRUCTIONS) THE FLOOR FLANGES ONLY ADJUST 1”-1 1/4” DOWN MAXIMUM (SEE 2.2 BELOW), THEREFORE IF ANY GAP EXIST SHIMS MUST BE PLACED BETWEEN THE FLOOR FLANGE AND FLOOR TO PROPERLY LEVEL AND SECURE THE UNIT.
  - c. TO LEVEL THE TUMBLE CHILLER/COOK TANK FRONT TO BACK PLACE A LEVEL ON THE SHROUD AGAINST THE TANK ON THE DRIVE SIDE AND USING A 4’ LEVEL USE THE (2) LEVELING CENTER PUNCHES ON THE IDLER SIDE OF THE TANK.
  - d. TO LEVEL THE TUMBLE CHILLER/COOK TANK 1/2” OUT OF LEVEL ON THE DRIVE SIDE OPEN BOTH COVERS. PLACE A 4’ LEVEL ON THE TANK FLANGE WITH A 1/2” SPACER UNDER THE RIGHT END OF THE LEVEL. NOW ADJUST THE LEGS UNTIL THE LEVEL SHOWS LEVEL. THIS WILL PUT THE TANK APPROX 1/2” OFF LEVEL. LOW ON THE DRIVE END WHERE THE TANK DRAIN IS.
  - e. THIRD – ONCE ALL FLANGES ARE SET AND THE TUMBLE CHILLER IS LEVEL FRONT TO BACK AND THE DRIVE END IS 1/2” LOWER THEN THE IDLER END, THE UNIT IS READY TO BE BOLTED TO THE FLOOR.

### TCCT-120-CC Floor Flange Adjustment:

**NOTES:**

AFTER UNIT IS LEVEL, ANCHOR ALL FLOOR FLANGES TO THE FLOOR BY USING AN ANCHOR BOLT IN EACH HOLE OF THE FLANGES.

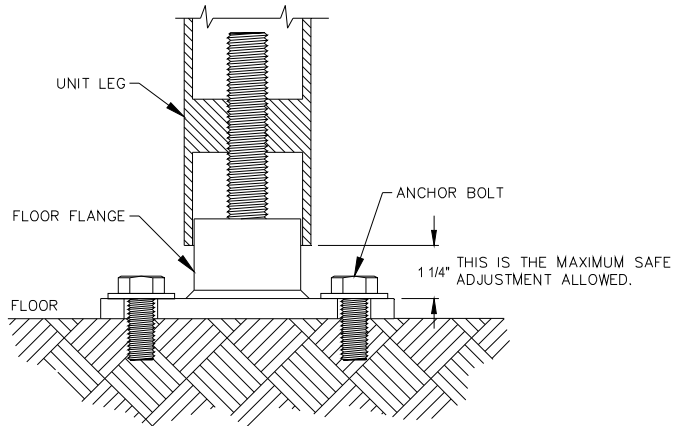

CORRECT ADJUSTMENT OF FLOOR FLANGE

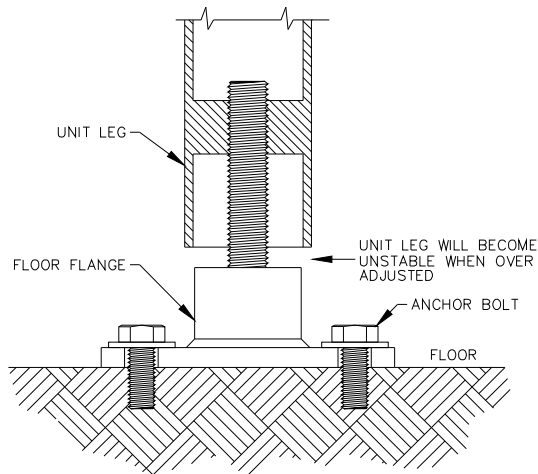

INCORRECT ADJUSTMENT OF FLOOR FLANGE

**OPERATING INSTRUCTIONS:  
DAILY PRE-START UP**

1. The operator must check that the basket door is closed, latched and that the tank cover/covers are completely closed before turning power on.
2. All panels must be in place and secured before turning power on.
3. Make sure the basket racks are properly installed and filled for cooking or removed for cooling before filling tank.

**Note:**

- The pressure drop is 12 to 15 PSI for chilled water passing through the heat exchanger.
- Compressed Air must be dry, clean and free of oil to prevent any damage to components and/or reduce the life of parts used in processing.

## Production Mode

### A. Chiller for Kettle Cooked Foods:

1. Open outer cover with Tumble Chiller/Cook Tank-120 – lift right hand cover first.
2. Loosen large clamps at front of inner rotating drum and raise door of drum to the open position.
3. Start each operation with the CONTROL POWER and SELECT switch “OFF”

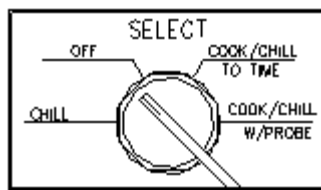
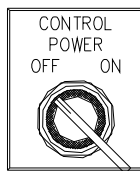

4. To Start: Turn CONTROL POWER switch “ON” and pull out Red Emergency Stop Button.
5. Begin chilling cycle by:
  - A. Set Select switch to chill
  - B. Push green button marked Tank Run:  
This begins the filling of the Cook/Chill Tank with water up to chill water low level probe.
  - C. After tap water rises past the lower water level probe the water pumps come on – circulating pump moves the water from the chill tank through the heat exchanger while the chilled water pump moves water from the ice builder to the shell side of the heat exchanger.
6. Load in up to 120 gallons of hot pumped kettle cooked product in casings. Close the inner perforated drum cover by releasing the latch located on the right hand side of the cover. Secure all large clamps at front edge of the inner rotating drum.
7. Close outer tank cover beginning with the left hand cover.
8. To start rotation of inner drum push green cylinder rotation button to ROTATE. Green light will turn on.

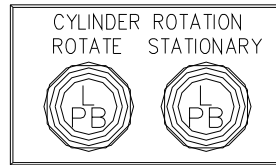

9. A. Observe actual tank water temperature by digital readout located lower right hand on the Chart Recorder.

NOTE: Water temperature set control is by passed.

- B. The water in tank is constantly recorded by the green pen in the Temperature Recorder.

- C. Depending on product viscosity, it will take from 30-75 minutes to cool down the product from 165° to 40°F once the drum has started rotating. The red light will come on to show the tank cooling water is at 40°F. This usually means the product is 2-3° higher in temperature, but it is best to check several casings in each batch to establish a base line for this type of temperature correlation.

- D. The chill cycle will continue until it is turned off.

IMPORTANT: A safety interlock is built into the system. Opening the cover will stop functions at once. Close the cover and rotation resumes. No other functions are effected by this safety interlock.

10. To stop the chill cycle and remove chilled casings to refrigerate storage:

- A. Stop drum rotation – Push Yellow STATIONARY Button. The drum will continue to the proper horizontal open point.

Yellow STATIONARY Light goes on when the drum is in the proper position to open.

- B. Terminate chill cycle (pumps stop) by one of two methods:

- 1.If more food is going to be chilled – stop pumps by pushing in the Tumble Chiller Emergency Stop button. This will save chilled water for the next batch.

2. To empty water from the tank, if there is no more food to chill, turn select switch to OFF.

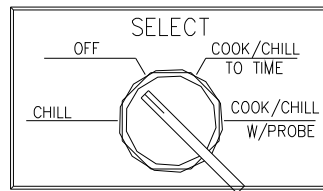

### B. Overnight Cooking Using Meat Probe.

1. Open outer cover beginning with right hand cover first .
2. Loosen large clamps at front of inner rotating drum and raise door of drum to the open position, will lock into place with a right hand catch.
3. Start each operation with “SELECT” switch OFF

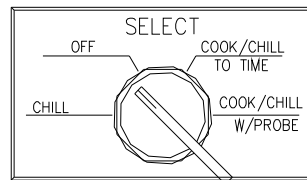

4. To load cook tank:
  - A. Place single narrow rack in center of drum bottom – the prongs will fit into the drum holes.  
Place 1-2 rows of vacuum bagged product along each side of the divider.
  - B. Place larger rack with risers (risers facing upward) as the next row and load product on rack.  
NOTE: Do not overlap the product. It should be a single layer.
  - C. Place the next rack and load product.
  - D. Place hold -down rack slightly above the last load of product. Hold -down rack has locking pins. Push pin through drum perforations to secure in place.

5. To put meat probe in product:
- A. Wash probe with alcohol swab.
  - B. Insert meat probe through large hole in cook tank and through hole in drum.
  - C. Before putting last rack in place, put a second bag around the largest roast.
  - D. Puncture the vacuumed bag of the largest roast with the probe. The tip of the probe must be in the center of the muscle.
- NOTE: Avoid getting the probe near a bone or fat clod.
- E. Gather the second bag around the meat probe wire. Secure tightly with a wire tie or string. Place the bag through the opening of the two grids so the opening of the bag extends above the water line. This prevents meat juices from getting into the water bath.

6. Check the Main Control Power is “ON”.

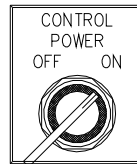

**WARNING: Be sure the yellow STATIONARY light is on. DO NOT push ROTATE.**



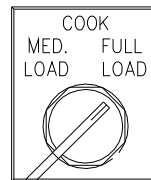

7. Set water level switch to MEDIUM or FULL LOAD.

IMPORTANT: The water level must completely cover the cook-in-casing products or incomplete cooking will occur.







8. Check to be sure the red emergency stop button is pulled out on the control panel.
9. To set cooking cycle: Set select switch to COOK/CHILL WITH PROBE.
10. Set required process time

NOTE: Maximum timer setting is 99 hours 59 minutes.

- A. Press P1 to bring up “0000” on display.
  - B. Press button under each “0” to display a number for that digit.
  - C. Press (E) for Enter.
  - D. Press (R) for Recall to display set time. Timer will clock down to 0000.
11. Set probe temperature set point. Push  or  buttons to change temperature setting.
  12. Set cook tank water temperature: Push  or  buttons to change/set temperature setting approximately 5-7°F higher than probe temperature set point.
  13. Start cooking cycle by pressing green button marked “**RUN**”. After cook cycle is finished, the chill cycle starts. The hot water is dumped for 5 minutes, cold tap water refills to high water level, and cooling cycle begins and runs until operator shuts down system.
  14. To drain tank, turn Select switch to off.

### **C. Overnight Cooking To Time and Temperature Without Meat Probe:**

1. Follow instructions for Step B
2. Set cook tank water temperature set point: Push  or  buttons to set temperature approximately 5-7°F higher than the required product temperature. Push until  display Control, Push  to lock temperature in place.
3. Start cooking cycle by pressing green button marked “**RUN**”.
4. Observe green pen for water temperature in tank. When water temperature is reached, timer will clock down to “0”; the unit will automatically go into the chill cycle and continue until the unit is turned off the unload.

**NOTE:** Put finished product into food bank as soon as possible after unloading.

**D. Rethermalizing/Cooking In Casing, Such as Eggs & Flaked Potatoes:**

1. Determine if drum shall rotate or stay stationary and press green or yellow push button.

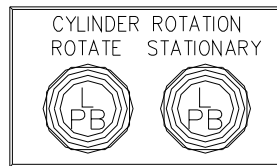

**IMPORTANT** – If in “**ROTATE**” remove all hold down grids before loading.

Disregard Step 4, Section C.

2. Set controls as listed in steps 1-12, Section B

**E. Use Soak Cycle with Cook Tank Overnight Cooking:**

1. This function is provided when partially frozen meat or poultry products are to be cooked overnight. A soak or thaw period is provided by circulating tap water for a fixed time period before the cook cycle begins.
2. Set up the tank and controls by following:

**SECTION C:** Cook tank for overnight cooking to time and water bath temperature without meat probe.

1. Start soak cycle with yellow push button marked “**SOAK TIMER**”.

**REMEMBER:** Time does not begin until water level reaches set point.

2. Set soak time by putting in time (hours and minutes) at timer marked “**SOAK TIMER**”.

A. Press P1 to bring up 0000 on display.

B. Press button under each 0 to display a number for that digit.

C. Press (E) for Enter.

D. Press (R) for Recall to display set time. Timer will clock down to 0000.

When the soak cycle times out the cook cycle will begin.

**Soak Timer Settings:**

- Small (up to 2” thick) – 1 hour soak.
- Medium (2” to 5” maximum thickness) – 2 hours soak.
- Large Roasts (5” to 9” thick) – 3 hours soak.

3. See steps 9-14

## **POST PRODUCTION & SHUT DOWN**

WHEN SHUTTING THE TUMBLE CHILLER DOWN FOR AN EXTENDED PERIOD OF TIME IT IS IMPORTANT TO:

- DRAIN ALL WATER FROM THE TANK.
- DO NOT LEAVE PRODUCT IN THE RACKS OR TANK.
- THE UNIT SHOULD BE TURNED OFF.
- IF UNIT IS TO BE OUT OF OPERATION FOR MORE THAN A FEW DAYS, THE MAIN POWER SHOULD BE DISCONNECTED (VIA CUSTOMER SUPPLIED MAIN DISCONNECT), ALL UTILITIES SHOULD BE TURNED OFF AT THE UNIT.

## **EMERGENCY OPERATIONS**

**CAUTION:** improper sequencing or activation of manual controls could cause personal injury or damage to the unit.

- Never run either of the pump motors without water, damage will occur when run dry.
- Do not run the Main Agitation Pump without the rear screen in place. Large objects, tools, ect could be pulled in to the inlet and damage the pump. Personal injury is possible as well.
- Special care should be taken if running the unit with the covers open.
- In the event of a fire or explosion, the main power should immediately be shut off via the main disconnect.

**CLEANING:**



**Care and Cleaning**

Cooking equipment must be cleaned regularly to maintain its fast, efficient cooking performance and to ensure its continued safe, reliable operation. The best time to clean is shortly after each use. (allow unit to cool to a safe temperature).

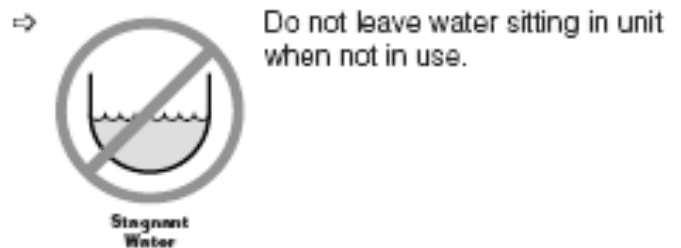
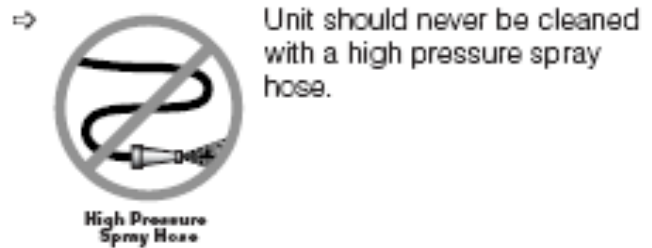
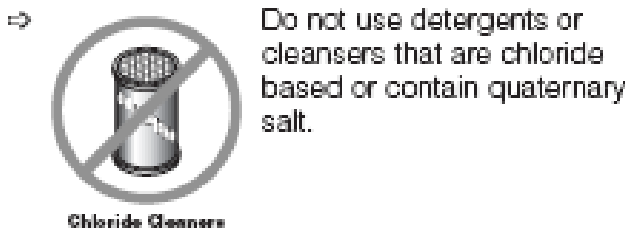

### **Tumble Chiller Cook Tank Cleaning Instructions**

- The tank drain inlet on the inside of the tank has a screen covering. Clean the screen using a power washer or high pressure hose. Only use high pressure water on the drain screen no other part of the Tumble Chiller Cook Tank.
- With a non-metallic scraper or brush remove all food particles/patches that are on the rotating basket inside and outside as well as the inside of the tank.
- Remove the racks from inside the rotating basket and clean in a sink.
- Wash inside and outside of basket, then inside of tank and rinse completely.

### **To remove Tumble Chiller Cook Tank Inner Drum**

- For removal of inner drum on tumble chiller make sure it is the “UP” position.
- Remove the two (two) bolts on the right-hand side, push center knob of the pin,
- remove pin, and carefully lift the basket out of the tank.

When reinstalling basket, line up holes on the basket shaft and the stub shaft. Push center knob of pin and insert pin into holes.

**NOTE:** If the pin does not go in easily, the holes are not properly aligned.

**DO NOT FORCE.**

Install the bolts and make sure they are tight.

#### **Notes:**

1. For more difficult cleaning applications one of the following can be used: alcohol, baking soda, vinegar, or a solution of ammonia in water.
2. For more detailed instructions refer to the Nafem Stainless Steel Equipment Care and Cleaning manual.

**NAFEM STAINLESS STEEL EQUIPMENT CARE AND CLEANING MANUAL:**

(Supplied courtesy of Nafem. For more information visit their web site at [www.nafem.org](http://www.nafem.org))

**Contrary to popular belief, stainless steels ARE susceptible to rusting.**

Corrosion on metals is everywhere. It is recognized quickly on iron and steel as unsightly yellow/orange rust. Such metals are called “active” because they actively corrode in a natural environment when their atoms combine with oxygen to form rust.

Stainless steels are passive metals because they contain other metals, like chromium, nickel and manganese that stabilize the atoms. 400 series stainless steels are called ferritic, contain chromium, and are magnetic; 300 series stainless steels are called austenitic, contain chromium and nickel; and 200 series stainless, also austenitic, contains manganese, nitrogen and carbon. Austenitic types of stainless are not magnetic, and generally provide greater resistance to corrosion than ferritic types.

With 12-30 percent chromium, an invisible passive film covers the steel’s surface acting as a shield against corrosion. As long as the film is intact and not broken or contaminated, the metal is passive and stain-less. If the passive film of stainless steel has been broken, equipment starts to corrode. At its end, it rusts.

**Enemies of Stainless Steel**

There are three basic things which can break down stainless steels passivity layer and allow corrosion to occur.

1. Mechanical abrasion
2. Deposits and water
3. Chlorides

**Mechanical abrasion** means those things that will scratch a steel surface. Steel pads, wire brushes and scrapers are prime examples.

**Water** comes out of the faucet in varying degrees of hardness. Depending on what part of the country you live in, you may have hard or soft water. Hard water may leave spots, and when heated leave deposits behind that if left to sit, will break down the passive layer and rust stainless steel. Other deposits from food preparation and service must be properly removed.

**Chlorides** are found nearly everywhere. They are in water, food and table salt. One of the worst chloride perpetrators can come from household and industrial cleaners.

## **So what does all this mean? Don't Despair!**

Here are a few steps that can help prevent stainless steel rust.

### **1. Use the proper tools:**

When cleaning stainless steel products, use non-abrasive tools. Soft cloths and plastic scouring pads will not harm steel's passive layer. Stainless steel pads also can be used but the scrubbing motion must be in the direction of the manufacturers' polishing marks.

### **2. Clean with the polish lines:**

Some stainless steel comes with visible polishing lines or "grain." When visible lines are present, always scrub in a motion parallel to the lines. When the grain cannot be seen, play it safe and use a soft cloth or plastic scouring pad.

### **3. Use alkaline, alkaline chlorinated or non-chloride cleaners.**

While many traditional cleaners are loaded with chlorides, the industry is providing an ever-increasing choice of non-chloride cleaners. If you are not sure of chloride content in the cleaner used, contact your cleaner supplier. If your present cleaner contains chlorides, ask your supplier if they have an alternative. Avoid cleaners containing quaternary salts; it also can attack stainless steel and cause pitting and rusting.

### **4. Treat your water:**

Though this is not always practical, softening hard water can do much to reduce deposits. There are certain filters that can be installed to remove distasteful and corrosive elements. To insure proper water treatment, call a treatment specialist.

### **5. Keep your food equipment clean:**

Use alkaline, alkaline chlorinated or non-chloride cleaners at recommended strength. Clean frequently to avoid build-up of hard, stubborn stains. If you boil water in stainless steel equipment, remember the single most likely cause of damage is chlorides in the water. Heating cleaners that contain chlorides have a similar effect.

### **6. Rinse, rinse, rinse:**

If chlorinated cleaners are used, rinse and wipe equipment and supplies dry immediately. The sooner you wipe off standing water, especially when it contains cleaning agents, the better. After wiping equipment down, allow it to air dry; oxygen helps maintain the stainless steels passivity film.

### **7. Never use hydrochloric acid (muriatic acid) on stainless steel.**

### **8. Regularly restore/passivate stainless steel.**

**Recommended cleaners for specific situations:**Routine cleaning:

Use soap, ammonia, detergent, Medallion.  
Apply with cloth or sponge

Fingerprints & smears:

Use Arcal 20, Lac-O-Nu Ecoshine.  
Provides barrier film

Stubborn stains & discoloration:

Cameo, Talc, Zud, First Impression  
Rub in direction of polish lines

Grease & fatty acids, blood, burnt-on-foods:

Easy-off, De-Grease It Oven Aid  
Excellent removal on all finishes

Grease & oil:

Any good commercial detergent  
Apply with sponge or cloth

Restoration/Passivation:

Benefit, Super Sheen

## RECOMMENDED PREVENTIVE MAINTENANCE:

### 1. TESTING SAFETY RELIEF VALVE

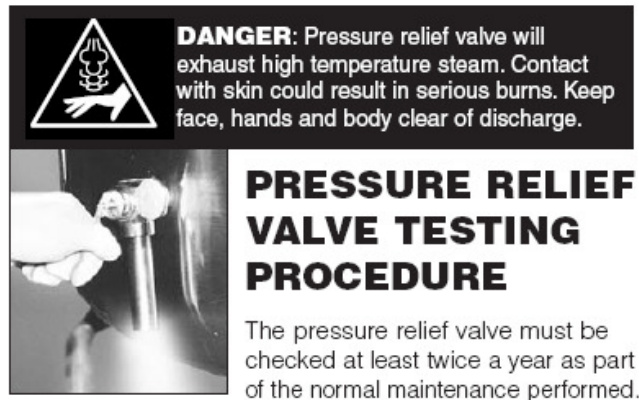

1. With the tank empty, fully open the steam valve and allow the tank to preheat.
  2. Stand to the side of the pressure relief valve discharge and pull valve open for a maximum of one second. Repeat test three to four times. Each time the mechanism should move freely and be accompanied by a rapid escape of steam.
- If valve appears to be sticking replace pressure relief valve.
  - If foreign material is discharged then drain tank and replace pressure relief valve.

### **WARNING:**

Improper refilling of tank jacket will result in irreversible damage to unit.

### 2. GLYCOL RESERVOIR FLUID:

#### **WARNING:**

**ONLY USE 30% DOWFROST HD OR EQUAL WHEN FILLING THE GLYCOL RESERVOIR TO INSURE PROPER OPERATION AND PROTECT THE SYSTEM.**

#### **GLYCOL FLUID USED:**

**30% DOWFROST HD (AN INHIBITED PROPYLENE GLYCOL HEAT TRANSFER FLUID) OR EQUAL**  
**FAILURE TO USE THIS FLUID MAY DAMAGE THE SYSTEM**

### 3. GENERAL TUMBLE CHILLER COOK TANK COMPONENTS:

#### 1.2. AIR PRESSURE

##### 1.2.1. WEEKLY

- 30 Psi Air Supply
- Check Air Filter Regulator For Moisture, and Dirt
- Air Must Be Clean And Dry
- Check All Air Lines & Fittings for Leaks

#### 1.3. LEAKS

##### 1.3.1. WEEKLY

- Check For Leaks Of Any Type ( Water - Air ) **WARNING -Leaks Take Away From Performance And Will Lead To Costly Repair .**

#### 1.4. CONTROL PANEL

##### 1.4.1. WEEKLY

- Signs Of Water Damage
- Check Operation Of Controls (switches, pushbuttons, counters)
- Check Operation Of Partlow Chart Recorder
- Check Chart Recorder Parts (pens, pen arms, paper, door gasket & window)
- Temperature Read Outs
- RTD Adjustments on Water Temperature Sensor and the Meat Probe
- Basket Rotation & Stopping in correct position

### 4. MONTHLY INSPECTIONS

- MAKE SURE TUMBLE CHILLER COOK TANK IS BOLTED SECURELY TO FLOOR, BOLTS MAY LOOSEN AFTER TIME.
- INSPECT THE FOLLOWING:
  - Incoming power and amp draws compare to name plate
  - Incoming air pressure (line 1cfm @ 65psi.)
  - Air filter regulator for moisture and/or dirt (Must be clean & dry)
  - Shaft Hub for signs of leaking
  - All air lines for leaks and signs of wear
  - Open all inline strainers, flush out. Remove and clean strainer screens if necessary.
  - The proper clearance where drive shaft penetrates the shaft seal
  - Make sure temperature sensor & meat probe are properly installed

- Chill water supply and return lines for leaks
- The control box and junction box for any signs of corrosion/moisture
- The complete operation of all controls
- Water level pressure switch operation and accuracy
- The cooling operation
- The cooking operation
- The operation of THE circulating pump
- Cover Support Arms (both covers)for wear or damage
- Grease the flange face bearing
- Grease the idler bearing
- Hoses and clamp for leaks and that clamps are tight
- Basket door safety latch for proper operation
- Check the racks for damages, broken wires that might puncture product bags or injure someone
- All proximity sensors for proper adjustment and operation
- Visually check the fluid level in the Glycol Reservoir and fill if necessary  
Use only the specified fluid type when filling the Glycol Reservoir.

**GLYCOL FLUID USED:  
30% DOWFROST HD  
(AN INHIBITED PROPYLENE  
GLYCOL HEAT TRANSFER  
FLUID) OR EQUAL**

**FAILURE TO USE THIS FLUID  
MAY DAMAGE THE SYSTEM**

**MAINTENANCE AND INSPECTION:****All Service Must Be Performed By A Qualified Service Technician.**

The tumble chiller cook tank requires very little preventative maintenance other than daily cleaning.

**1. See Component Manuals for Maintenance Instructions for pump & motor**

- Circulating pump
- Basket Rotation Motor

**2. See Component Manuals for Maintenance Instructions on these items**

- Heat Exchanger
- PLC Programmable Controller & Modules
- Chart Recorder

## 1. Cover Actuator Adjustment and Maintenance

### PROCEDURE TO TIGHTEN SPRING IN LID ACTUATOR

1. Make sure the cover is in the up position.
2. Hold tension on the allen wrench, remove the allen screws #4.
3. Pull down on allen wrench until the 2nd set of holes appears in line. Reinstall allen screws. Note the allen wrench should travel 1/4 turn (90°-100°).

### PROCEDURE FOR REPLACING SPRING IN LID ACTUATOR

1. Make sure the cover is in the up position and properly supported before removing any allen screws.
2. Using that allen wrench hold tension on the spring when removing the allen screws item #4 using the allen wrench unload the spring.
3. Carefully remove the allen screws #3 and remove the end plate.
4. Remove the old spring and centering rod.
5. Grease new spring and centering rod before installing them into housing, note use Chesterton 622 USDA approved or equal grease.
6. Replace the end plate and replace the allen screws item #3.
7. Using the allen wrench tighten the spring and align the holes.
8. Replace the allen screws item #4

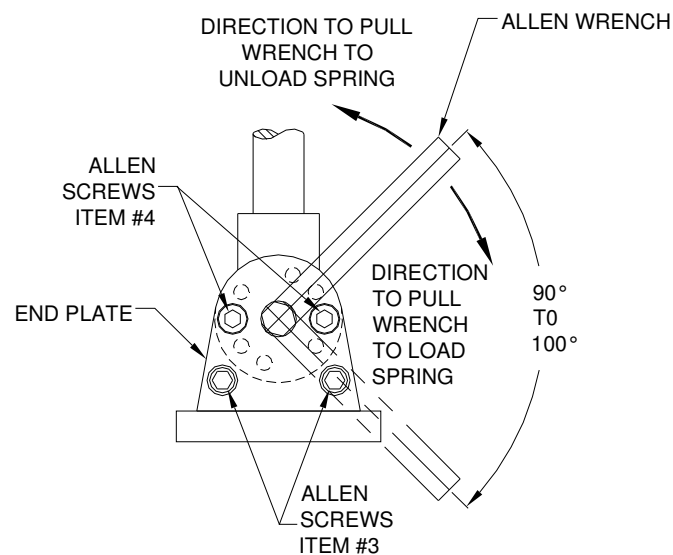

## 2. ASCO SOLENOID VALVE

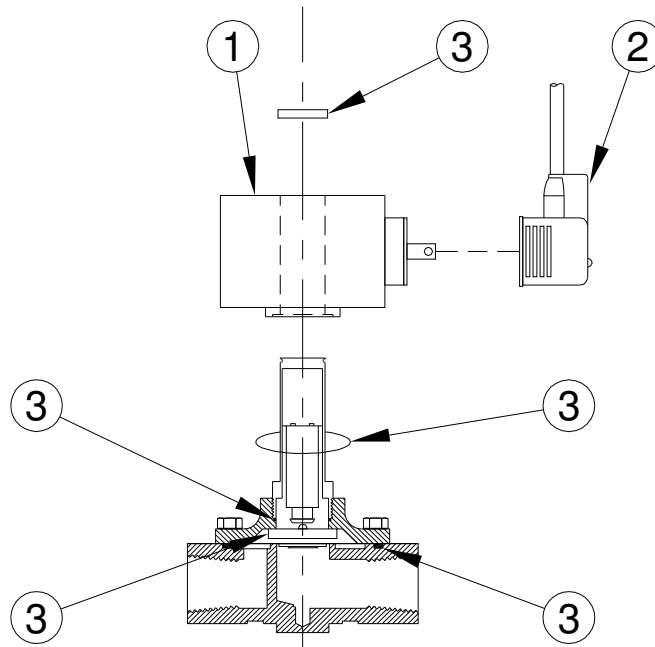

### BASIC ASCO SOLENOID CONSTRUCTION

1. COIL
2. DIN CONNECTOR
3. REPAIR KIT PARTS:
  - a. ALL INTERNAL GASKETS, SPRINGS, DIAPHRAGM, COIL POST, PLUNGER & CAP

**ELECTRICAL SCHEMATICS:  
 Tumble Chiller Cook Tank (208V-3PH-60HZ)**

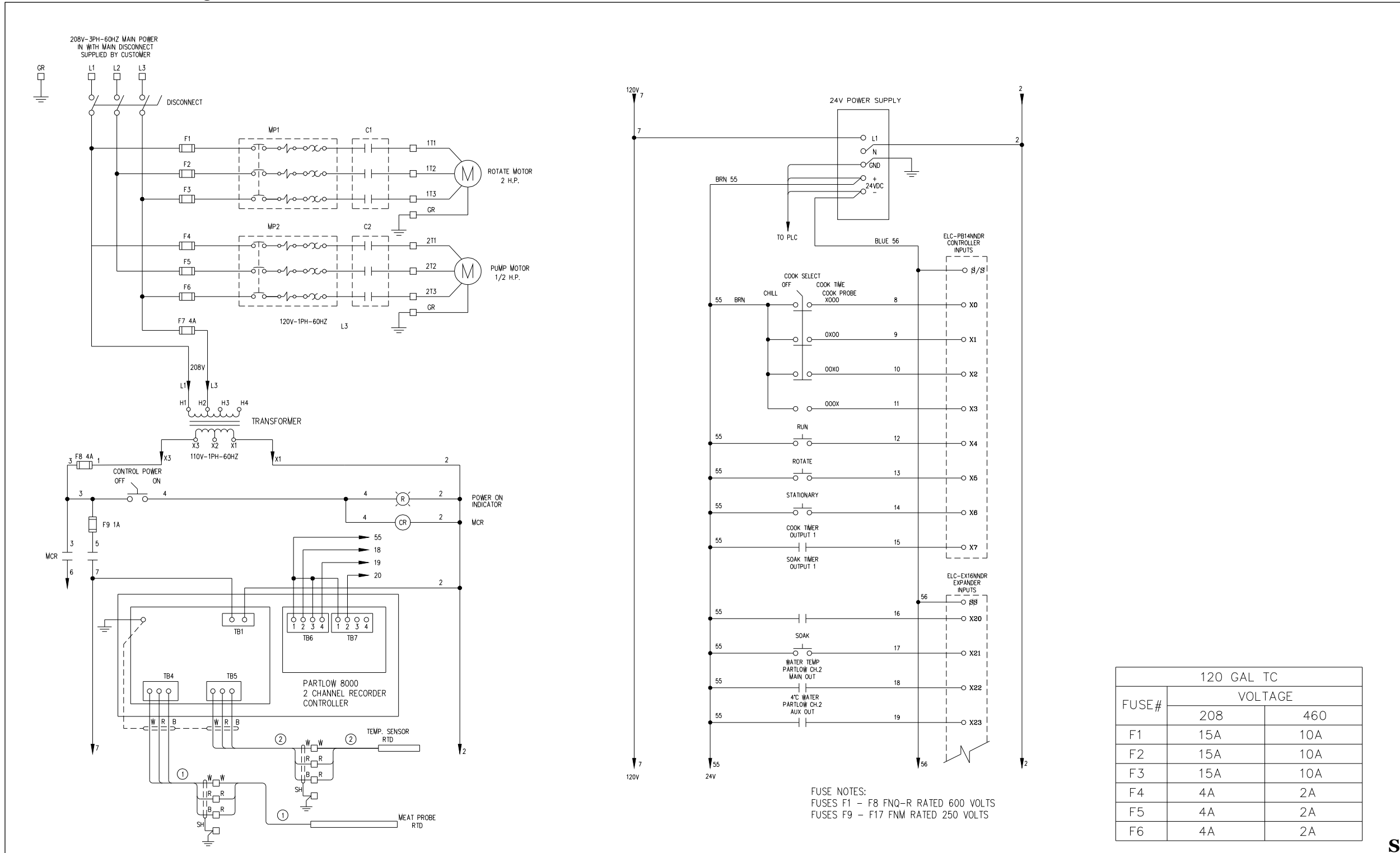

**SERIAL# WWWW  
 Drawing# B300025**

**Tumble Chiller Cook Tank – (continued)**

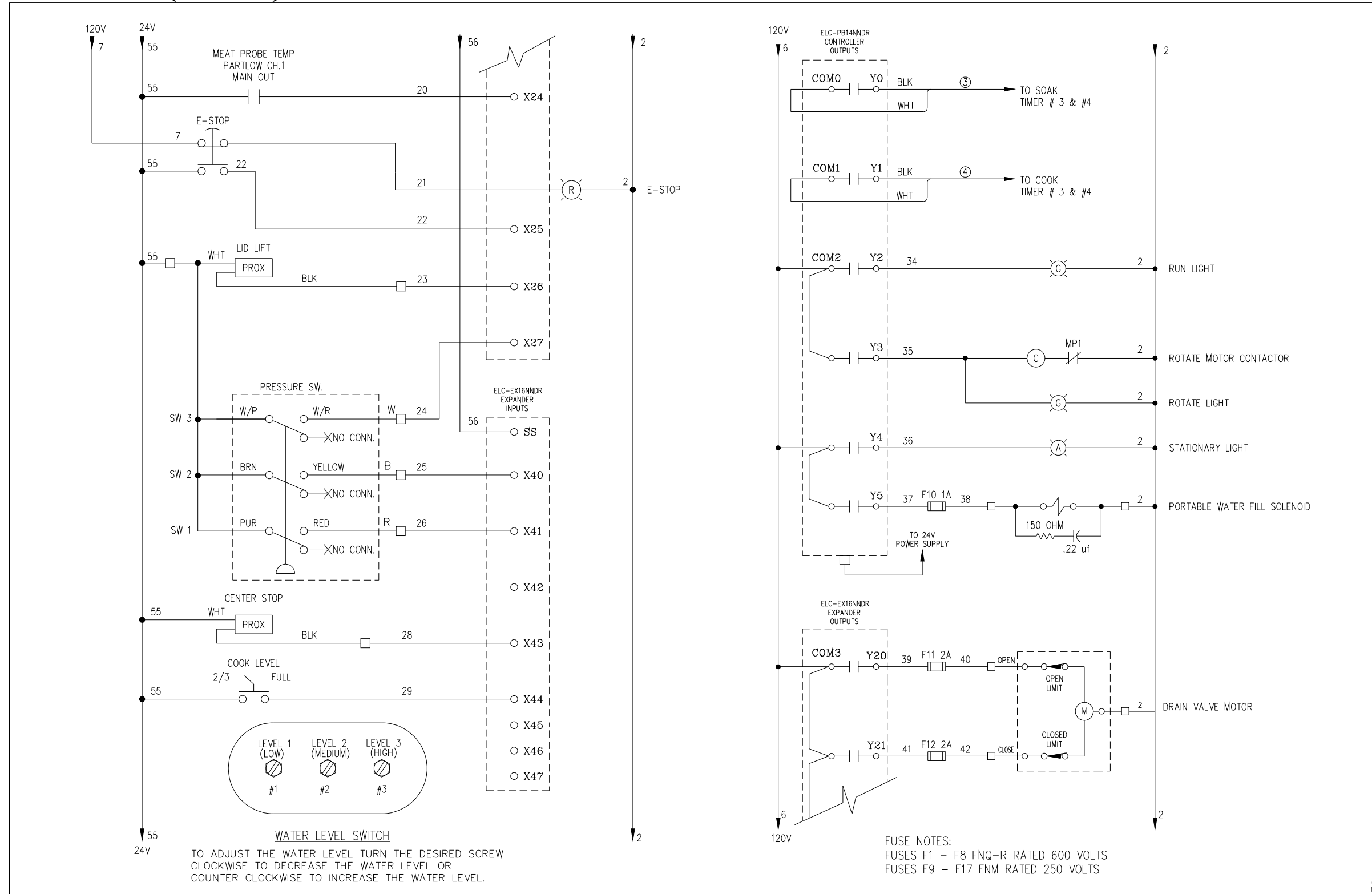

**SERIAL# WWWW**  
**Drawing# B300025**

**Tumble Chiller Cook Tank – (continued)**

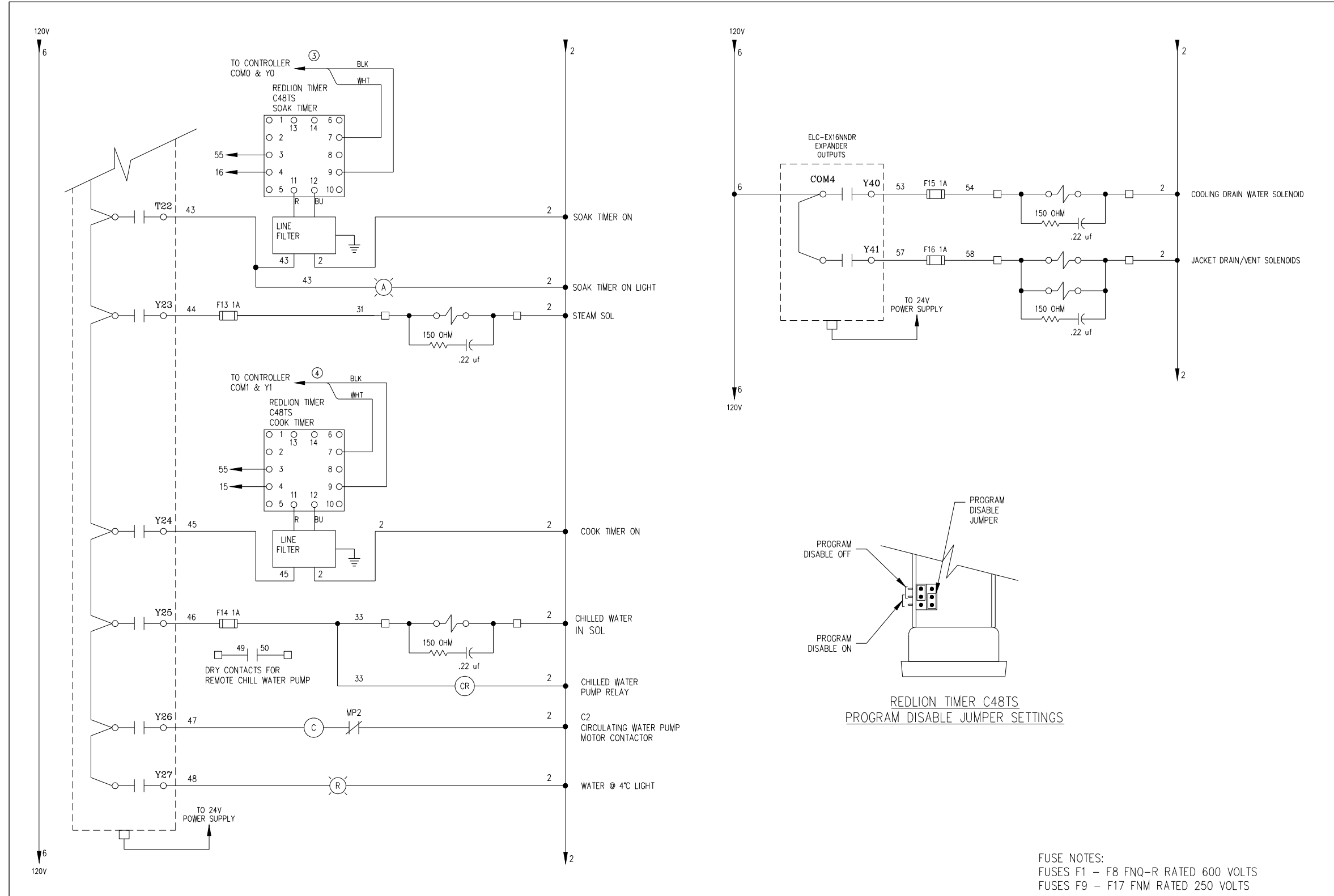

**SERIAL# WWWW**  
**Drawing# B300025**

**Tumble Chiller Cook Tank – (continued)**

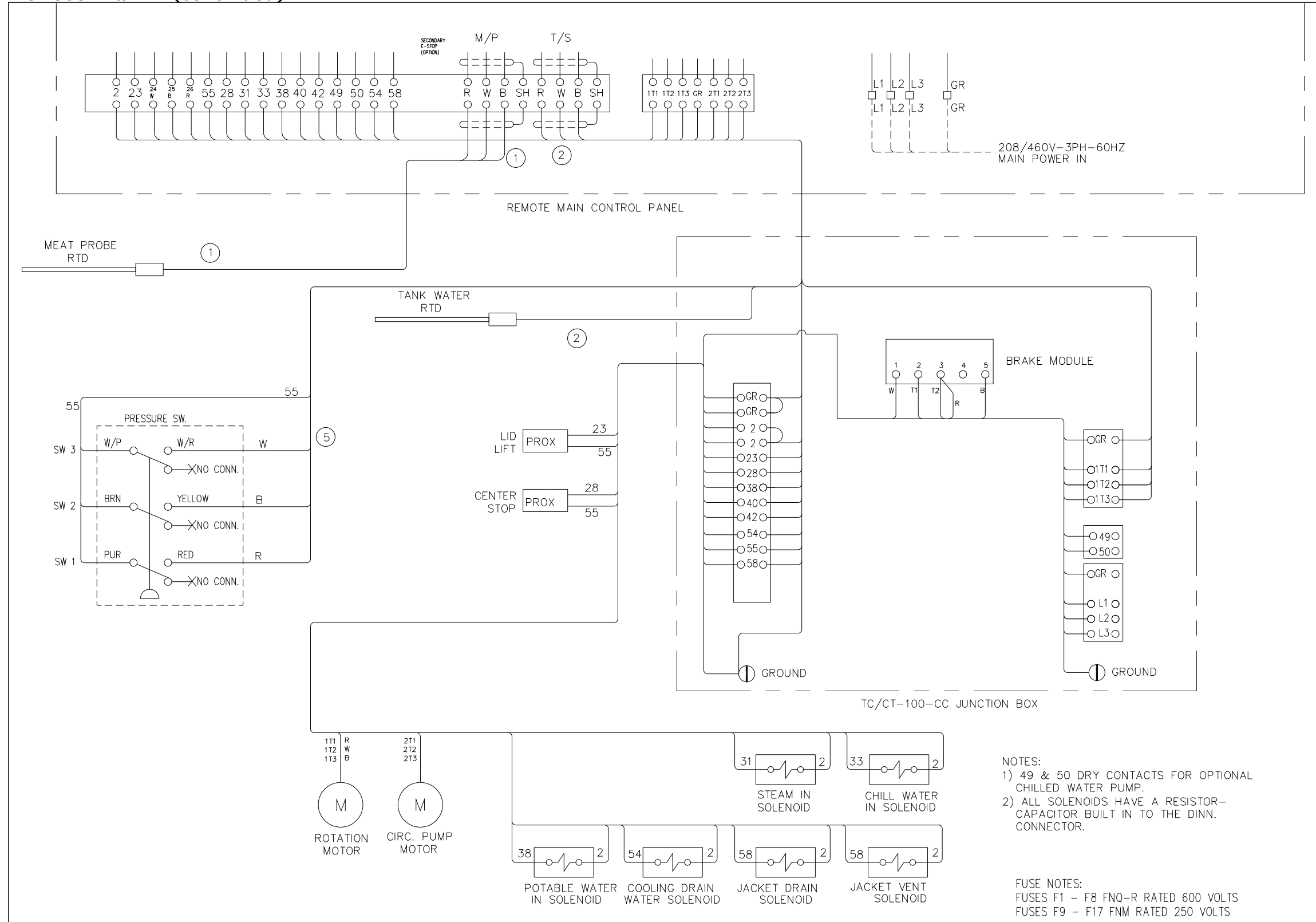

- NOTES:  
 1) 49 & 50 DRY CONTACTS FOR OPTIONAL CHILLED WATER PUMP.  
 2) ALL SOLENOIDS HAVE A RESISTOR-CAPACITOR BUILT IN TO THE DINN. CONNECTOR.

FUSE NOTES:  
 FUSES F1 – F8 FNQ-R RATED 600 VOLTS  
 FUSES F9 – F17 FNM RATED 250 VOLTS

**SERIAL# WWWW**  
**Drawing# B300025**

**Fuse Charts, Tumble Chiller Cook Tank**  
**SERIAL# WWWW**

FUSE CHART			
FUSE NO	TYPE	VOLT	AMP
F1	FNQ-R	600	15 AMP
F2	FNQ-R	600	15 AMP
F3	FNQ-R	600	15 AMP
F4	FNQ-R	600	4 AMP
F5	FNQ-R	600	4 AMP
F6	FNQ-R	600	4 AMP
F7	FNQ-R	600	4 AMP
F8	FNM	250	4 AMP
F9	FNM	250	1 AMP
F10	FNM	250	1 AMP
F11	FNM	250	2 AMP
F12	FNM	250	2 AMP
F13	FNM	250	1 AMP
F14	FNM	250	1 AMP
F15	FNM	250	1 AMP
F16	FNM	250	1 AMP

FIELD WIRING MUST ENTER/EXIT  
 ENCLOSURE THROUGH UL APPROVED FITTING  
 TYPE 4 OR 4X AND MUST BE RATED FOR 60° C  
 OR HIGHER USE COPPER CONDUCTORS ONLY.

Type 4 Enclosure

CLEVELAND RANGE, LLC

MODEL NO.: TCCT-120-CC  
 SERIAL NO.: 9400  
 LARGEST MOTOR RATING: 2 H.P.  
 RATED VOLTAGE: 208 V.A.C.  
 PHASE: 3 PH  
 CYCLES: 60 HZ  
 FULL LOAD CURRENT: 18 AMPS  
 MINIMUM CIR. AMPACITY: 20 AMPS  
 MAXIMUM OVERCURRENT DEVICE: 30 AMPS

SHORT CIRCUIT CURRENT:  
 rms SYMMETRICAL: 2 kA  
 MAXIMUM VOLTAGE: 208 V

### Glycol Reservoir Schematics (208V-3PH-60HZ)

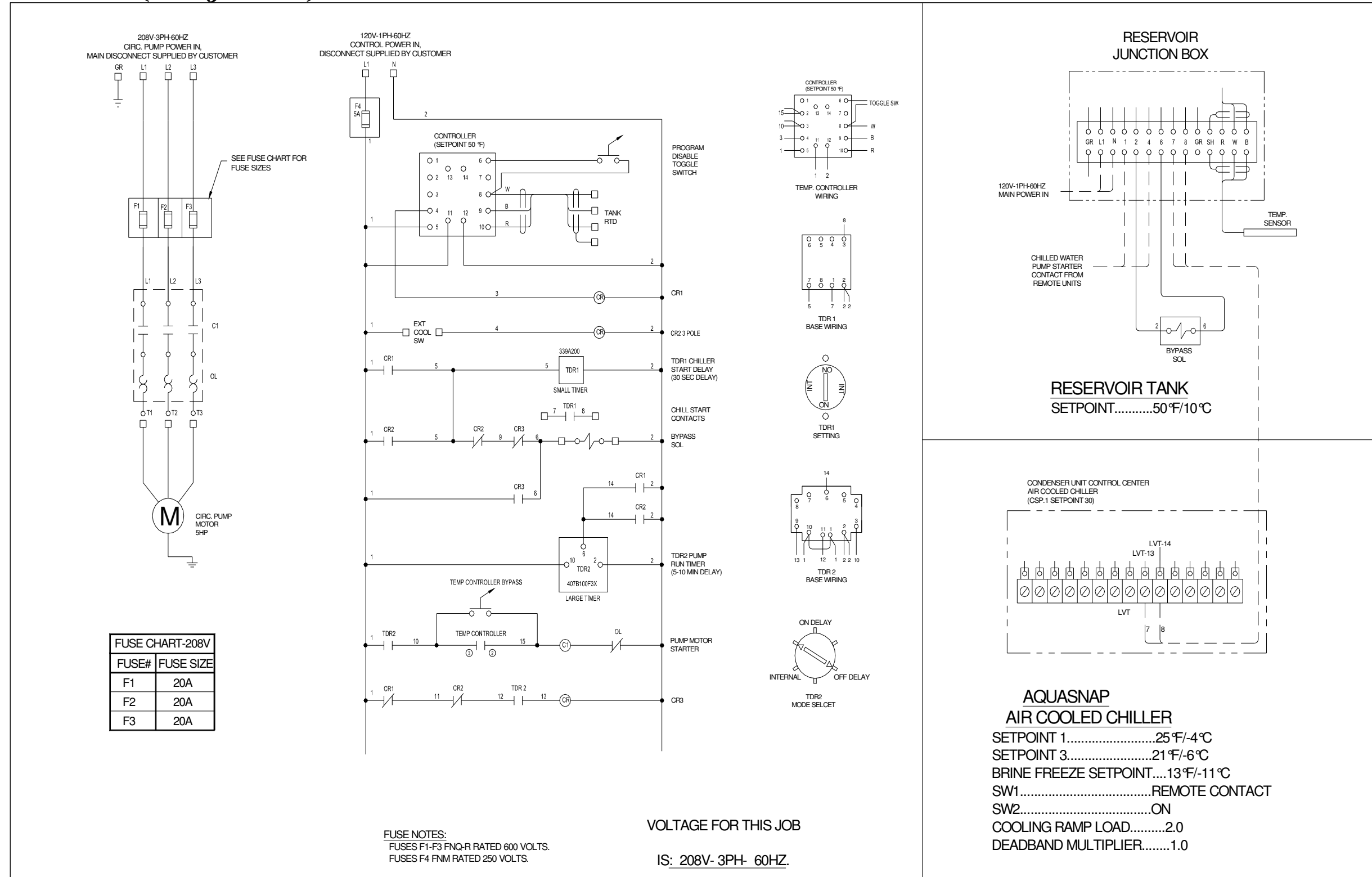

FUSE CHART-208V	
FUSE#	FUSE SIZE
F1	20A
F2	20A
F3	20A

FUSE NOTES:  
 FUSES F1-F3 FNQ-R RATED 600 VOLTS.  
 FUSES F4 FNM RATED 250 VOLTS.

VOLTAGE FOR THIS JOB  
 IS: 208V- 3PH- 60HZ.

**SERIAL# XXXX**  
**Drawing# B300009**

**Fuse Chart, Glycol Reservoir**  
**SERIAL# XXXX**

<b>FUSE CHART</b>			
FUSE NO	TYPE	VOLT	AMP
F1	FNQ-R	600	20 AMP
F2	FNQ-R	600	20 AMP
F3	FNQ-R	600	20 AMP
F4	FNQ-R	600	5 AMP

FIELD WIRING MUST ENTER/EXIT  
 ENCLOSURE THROUGH UL APPROVED FITTING.  
 TYPE 4 OR 4X AND MUST BE RATED FOR 60°C OR HIGHER  
 USE COPPER CONDUCTORS ONLY.

## TYPE 4 ENCLOSURE

**CLEVELAND RANGE, LLC**

MODEL NO.: TJ-100-CC  
 SERIAL NO.: 9411  
 LARGEST MOTOR RATING: 5 H.P.  
 RATED VOLTAGE: 208 V.A.C.  
 PHASE: 3 PH  
 CYCLES: 60 HZ  
 FULL LOAD CURRENT: 14 AMPS  
 MINIMUM CIR. AMPACITY: 15 AMPS  
 MAXIMUM OVERCURRENT DEVICE: 20 AMPS

RATED VOLTAGE: 120 V.A.C.  
 PHASE: 1 PH  
 CYCLES: 60 HZ  
 LARGEST MOTOR RATING: N/A  
 FULL LOAD CURRENT: 3 AMPS  
 MINIMUM CIR. AMPACITY: 4 AMPS  
 MAXIMUM OVERCURRENT DEVICE: 5 AMPS

SHORT CIRCUIT CURRENT:  
 rms SYMMETRICAL: 5 kA  
 MAXIMUM VOLTAGE: 208 V

**Settings Label, Aquasnap 20 Ton Air Chiller**  
**SERIAL# ZZZZ**

THE AQUASNAP UNIT REQUIRES  
THE FOLLOWING SETTINGS TO  
OPERATE AS REQ'D.. THE SETTINGS  
LISTED BELOW ARE TO BE SET BY  
A CERTIFIED CARRIER REP. AT TIME  
OF INSTALLATION/STARTUP.

AQUASNAP

AIR COOLED CHILLER

SETPOINT 1.....25 °F  
SETPOINT 3.....21 °F  
BRINE FREEZE SETPOINT....13 °F  
SW1.....REMOTE CONTACT  
SW2.....ON  
COOLING RAMP LOAD.....2.0  
DEADBAND MULTIPLIER.....1.0

**REPLACEMENT PARTS DRAWINGS:  
 Basic Tumble Chiller Cook Tank (208V)**

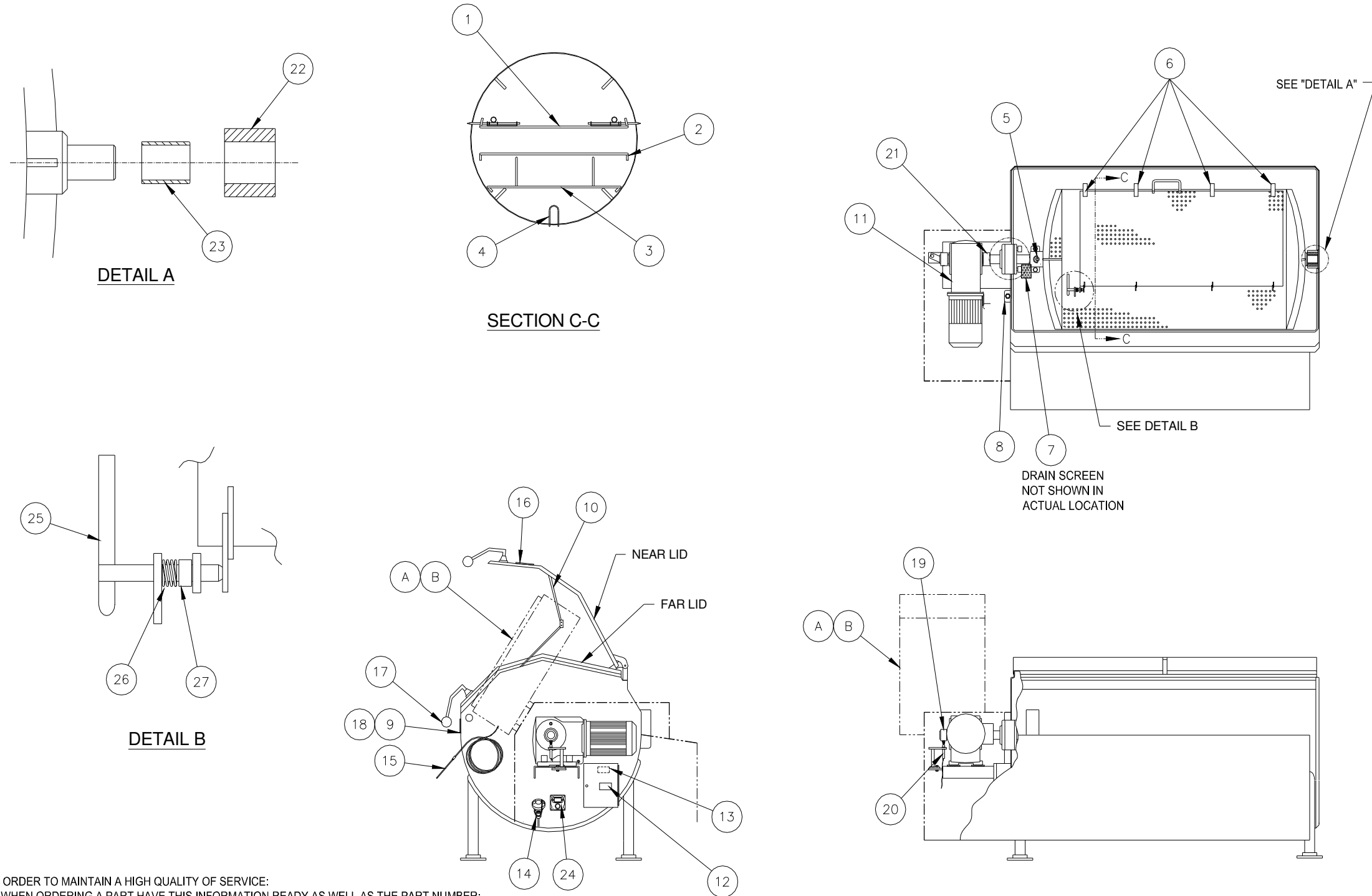

IN ORDER TO MAINTAIN A HIGH QUALITY OF SERVICE:  
 1. WHEN ORDERING A PART HAVE THIS INFORMATION READY AS WELL AS THE PART NUMBER:  
 SITE NAME/LOCATION, UNIT SERIAL NUMBER AND UNIT VOLTAGE.  
 2. CLEVELAND RANGE RESERVES THE RIGHT TO CHANGE ANY PART NUMBER WITHOUT NOTICE.

**SERIAL# WWWW  
 DRAWING# B600173**

**Basic Tumble Chiller Cook Tank (208V) – (continued)**

REPLACEMENT PARTS LIST		
ITEM	PART NO.	DESCRIPTION
1	2BSCREEN00001	TOP BASKET RACK (2 PER SET)
2	2BSCREEN00002	MIDDLE BASKET RACK (2 PER SET)
3	2BSCREEN00003	BOTTOM BASKET RACK (2 PER SET)
4	2BSCREEN00004	BOTTOM DIVIDER RACK
5	MSS00-3700001	QUICK RELEASE PIN
6	HWS00-3100002	BASKET LID LATCHES
7	2BSCREEN00005	DRAIN SCREEN
8	ELSWITCH00015	LID LIFT SENSOR
9	NPRED00000016	FUNCTION TAG
10	HWS01-0000002	LID SUPPORT ARM
11	DUH02-0000006	208V DRIVE ASSEMBLY
-	DU902-3800006	REPLACEMENT GEARBOX
-	DU902-0000007	REPLACEMENT 208V MOTOR
-	ELV02-0800001	REPLACEMENT 208V BRAKE

REPLACEMENT PARTS LIST		
ITEM	PART NO.	DESCRIPTION
12	NPRED000000006	WARNING TAG
13	SPRELAY000013	BRAKE MODULE
14	TSENSOR000006	TEMPERATURE SENSOR
15	TSENSOR000005	MEAT PROBE
16	NPRED000000010	WARNING TAG
17	MSP02-0000001	RED BALL
18	NPRED000000017	FUNCTION TAG
19	1FS00-0000057	SET COLLAR & INDICATOR
20	ELSWITCH00017	ROTATION STOP SENSOR
21	MSC02-0000001	SET COLLAR
22	FAA03-0000001	ACETAL IDLER BUSHING
-	HWS00-1300001	GREASE FITTING
23	FAS02-0000001	IDLER PIN SLEEVE
24	EL8SW-0000004	WATER LEVEL SWITCH
25	1FS00-5000003	HOLDING LATCH BASKET LID
26	MSSPRING00015	SPRING
27	HWS00-5000021	SET COLLAR

**IN ORDER TO MAINTAIN A HIGH QUALITY OF SERVICE:**

1. WHEN ORDERING A PART HAVE THIS INFORMATION READY AS WELL AS THE PART NUMBER:  
 SITE NAME/LOCATION, UNIT SERIAL NUMBER AND UNIT VOLTAGE.
2. CLEVELAND RANGE RESERVES THE RIGHT TO CHANGE ANY PART NUMBER WITHOUT NOTICE.

DRAWING LIST		
ITEM	DRAWING NO.	DESCRIPTION
A	B600175	CONTROL PANEL, EXTERIOR PARTS
B	B600176	CONTROL PANEL, INTERIOUR PARTS

**SERIAL#WWWW**  
**DRAWING# B600173**

**Tumble Chiller Cook Tank, Plumbing (208V)**

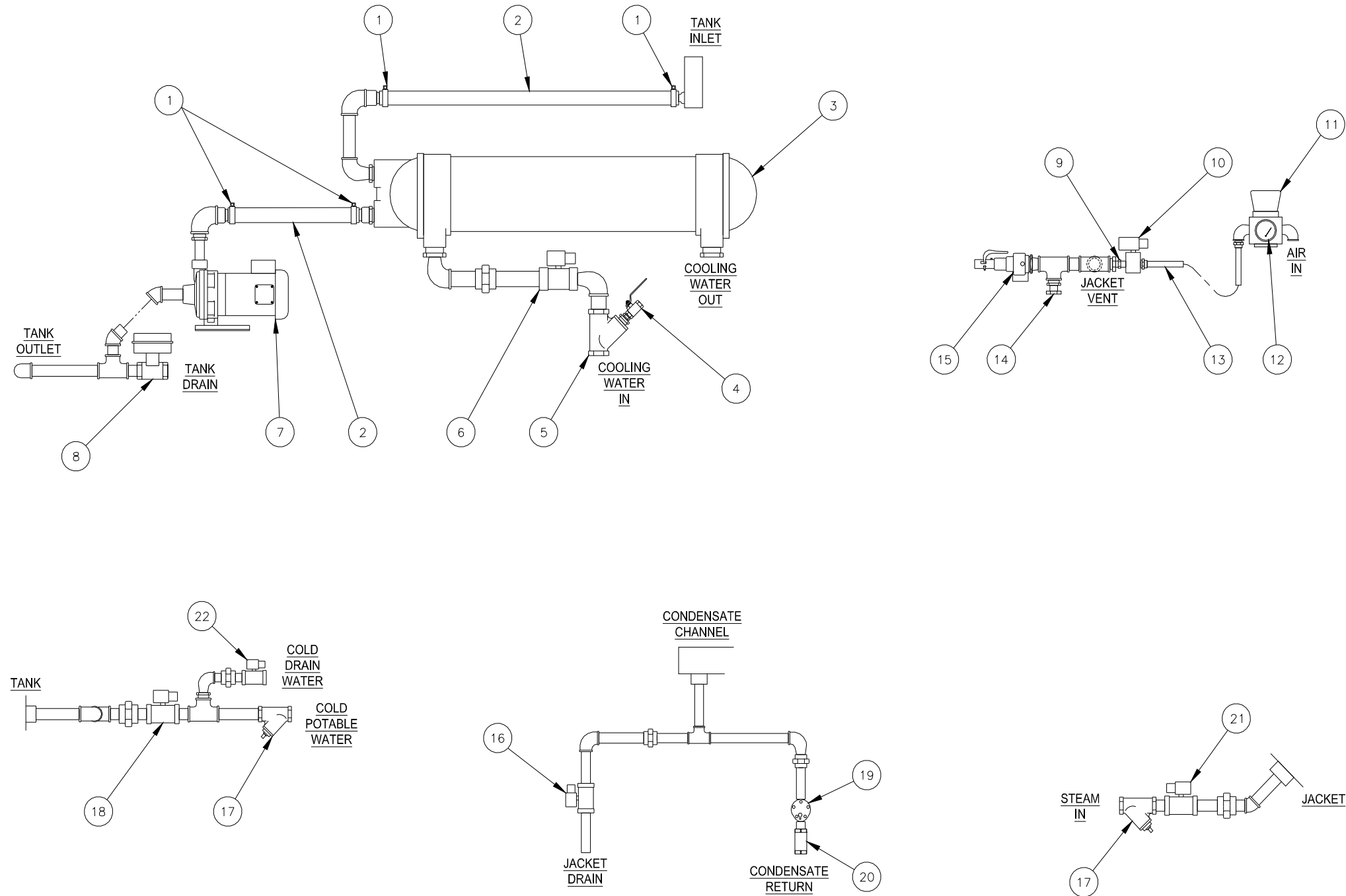

IN ORDER TO MAINTAIN A HIGH QUALITY OF SERVICE:  
 1. WHEN ORDERING A PART HAVE THIS INFORMATION READY AS WELL AS THE PART NUMBER:  
 SITE NAME/LOCATION, UNIT SERIAL NUMBER AND UNIT VOLTAGE.  
 2. CLEVELAND RANGE RESERVES THE RIGHT TO CHANGE ANY PART NUMBER WITHOUT NOTICE.

**SERIAL# WWWW**  
**DRAWING# B600174**

**Tumble Chiller Cook Tank, Plumbing – (continued)**

REPLACEMENT PARTS LIST		
ITEM	PART NO.	DESCRIPTION
1	HWS02-0000006	HOSE CLAMPS
* 2	PBD01-5000005	CIRCULATING WATER HOSE
3	MSC00-0000002	HEAT EXCHANGER
4	MSB00-5000004	BALL VALVE
5	MSB01-5000001	STRAINER
-	MSB01-5000003	REPLACEMENT SCREEN
6	ELB01-5000006	COOLING WATER IN SOLENOID
-	SP999-9900014	REPAIR KIT
-	SP988-8800002	REPLACEMENT COIL
-	ELP00-0000000	REPLACEMENT CONN.
7	MOMOTORS00002	CIRCULATING PUMP 208/230/460V
8	ELS01-5000001	DRAIN VALVE ASSY., 120V
-	ELMISC0000001	REPLACEMENT ACTUATOR 120V
-	ELS01-2500001	REPLACEMENT BALL VALVE
9	VAB00-2500001	NO LEAK CHECK VALVE
10	ELB00-2500013	VENT SOLENOID
-	SP999-9900064	REPAIR KIT
-	SP988-8800002	REPLACEMENT COIL
-	ELP00-0000000	REPLACEMENT CONN.
11	AR800-3700002	AIR REGULATOR
12	AR800-2500004	REPLACEMENT GAUGE
13	AR700-3700001	AIR HOSE
14	VAB00-5000003	VACUUM BREAKER

\* CUSTOMER TO SPECIFY LENGTH

REPLACEMENT PARTS LIST		
ITEM	PART NO.	DESCRIPTION
15	VAB00-7500005	50 PSI SAFETY VALVE
16	ELB00-7500015	JACKET DRAIN SOLENOID
-	SP999-9900004	REPAIR KIT
-	SP988-8800002	REPLACEMENT COIL
-	ELP00-0000000	REPLACEMENT CONN.
17	MSB01-0000001	STRAINER
-	MSB01-0000004	REPLACEMENT SCREEN
18	ELB01-0000012	POTABLE WATER IN SOLENOID
-	SP999-9900001	REPAIR KIT
-	SP988-8800001	REPLACEMENT COIL
-	ELP00-0000000	REPLACEMENT CONN.
-	ELP00-0000000	REPLACEMENT CONN.
19	MSC00-7500010	STEAM TRAP
-	SP999-9900075	REPAIR KIT
-	SP999-9900076	REPLACEMENT SCREEN
20	MSB00-7500004	BALL CONE CHECK VALVE
21	ELB01-0000013	STEAM IN SOLENOID
-	SP999-9900005	REPAIR KIT
-	SP988-8800002	REPLACEMENT COIL
-	ELP00-0000000	REPLACEMENT CONN.
22	ELB00-0500015	COLD DRAIN WATER SOLENOID
-	SP999-9900002	REPAIR KIT
-	SP988-8800002	REPLACEMENT COIL
-	ELP00-0000000	REPLACEMENT CONN.

IN ORDER TO MAINTAIN A HIGH QUALITY OF SERVICE:

1. WHEN ORDERING A PART HAVE THIS INFORMATION READY AS WELL AS THE PART NUMBER:  
 SITE NAME/LOCATION, UNIT SERIAL NUMBER AND UNIT VOLTAGE.
2. CLEVELAND RANGE RESERVES THE RIGHT TO CHANGE ANY PART NUMBER WITHOUT NOTICE.

**SERIAL# WWWW**  
**DRAWING# B600174**

**Tumble Chiller Cook Tank, Shaft Seal and Bearing**

REPLACEMENT PARTS LIST		
ITEM	PART NO.	DESCRIPTION
1	BGC02-0000001	FLANGE BEARING
2	SEDSEALS00001	OIL SEAL
3	SE3QRING00001	QUAD RING
4	1FS05-0000002	SEAL RETAINER PLATE
5	1HS00-3800001	RETAINER KNOB
6	1FS02-3800003	DRIVE SHAFT

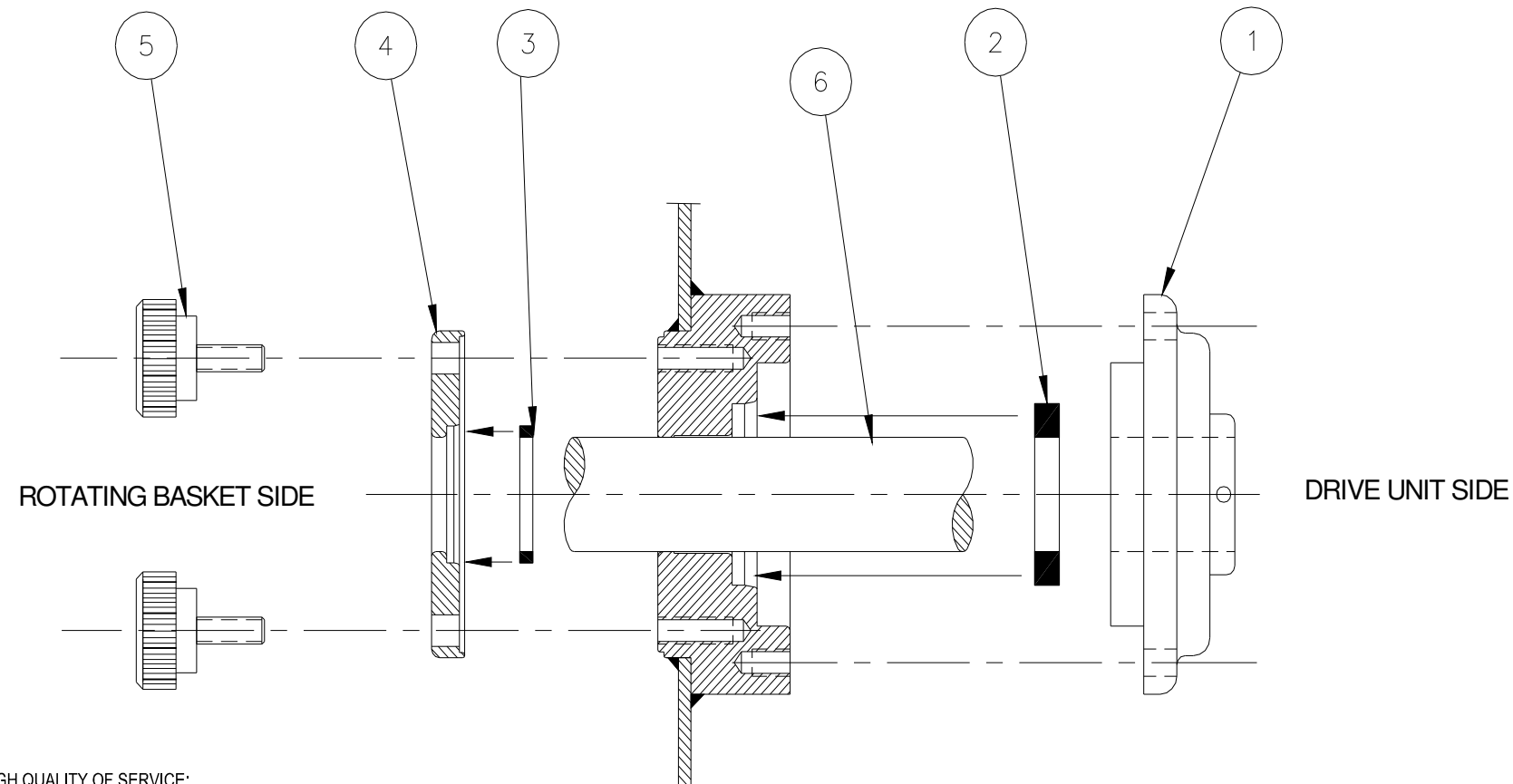

IN ORDER TO MAINTAIN A HIGH QUALITY OF SERVICE:  
 1. WHEN ORDERING A PART HAVE THIS INFORMATION READY AS WELL AS THE PART NUMBER:  
 SITE NAME/LOCATION, UNIT SERIAL NUMBER AND UNIT VOLTAGE.  
 2. CLEVELAND RANGE RESERVES THE RIGHT TO CHANGE ANY PART NUMBER WITHOUT NOTICE.

**SERIAL# WWWW**  
**DRAWING# B600177**

### Tumble Chiller Cook Tank, Control Box, External

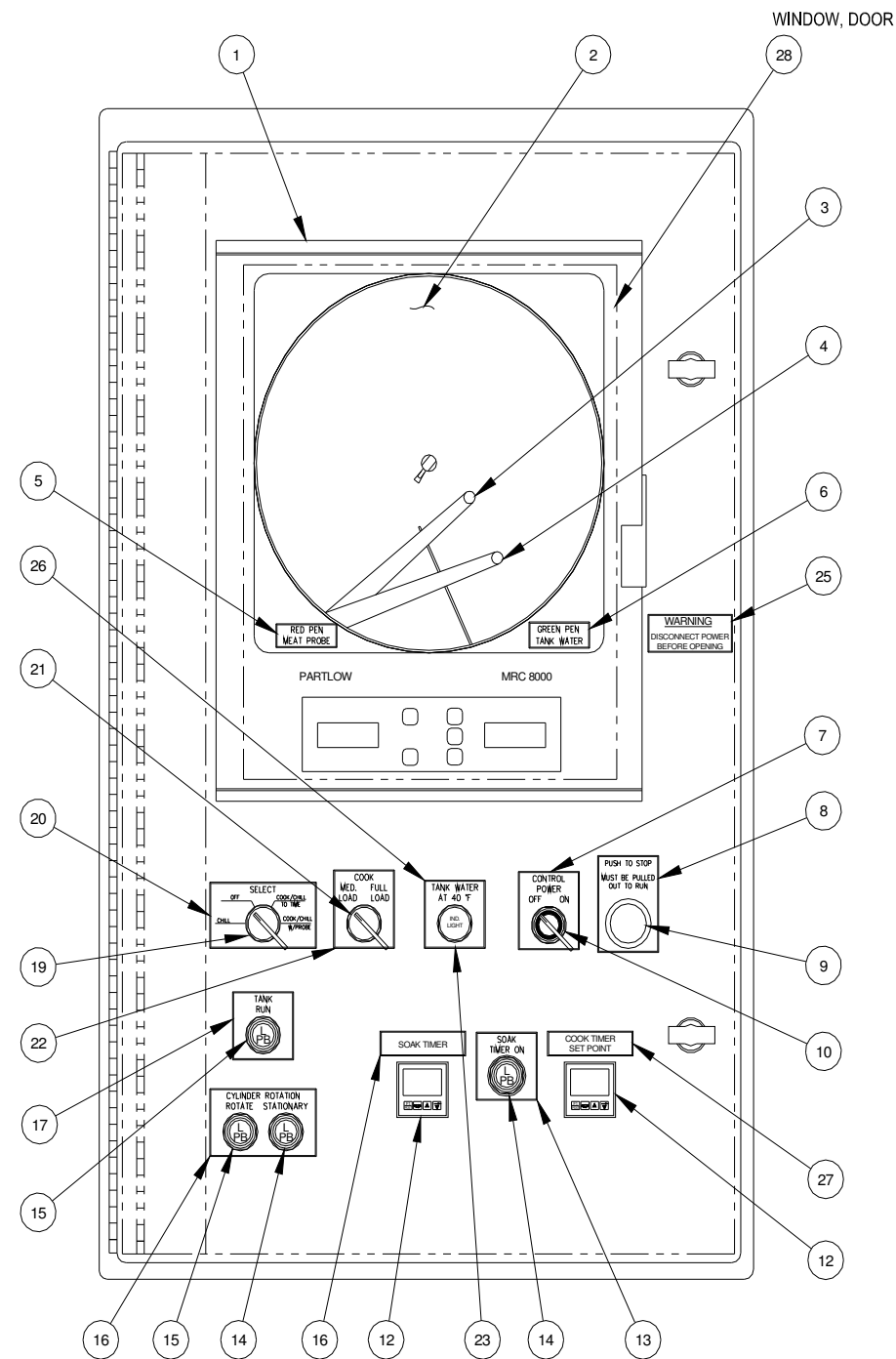

REPLACEMENT PARTS		
ITEM	PART NO.	DESCRIPTION
1	EL8CO-0000043	DUAL PEN PARTLOW 8000
-	EL977-7700018	CHART MOTOR FOR ITEM #1
-	EL977-7700019	PEN MOTOR FOR ITEM #1
-	EL977-7700022	MEMBRANE COVER FOR ITEM #1
2	MSJ00-0000005	24 HOUR CHART PAPER IN °F
3	MSP00-0000002	RED REPLACEMENT PEN
4	MSP00-0000001	GREEN REPLACEMENT PEN
5	NPYELLOW00142	NAMEPLATE
6	NPYELLOW00143	NAMEPLATE
7	NPYELLOW00110	NAMEPLATE
8	NPRED0000021	NAMEPLATE
9	2EP01-2500007	RED LIGHTED PUSH/PULL BUTTON
-	ELV00-0600001	REPLACEMENT LIGHT BULB FOR BUTTON #9
10	2EP00-8800025	RED LIGHTED TURN SWITCH
-	ELV00-6000001	REPLACEMENT LIGHT BULB FOR SWITCH #10
12	EL8CO-0000027	TIMER
-	ELV00-0000032	LINE FILTER, ITEM #12, ON BACK OF DOOR
13	NPYELLOW00145	NAMEPLATE
14	2EP00-8800021	AMBER LIGHTED PUSHBUTTON
-	ELV00-6000001	REPLACEMENT LIGHT BULB FOR BUTTON #14
15	2EP00-8800008	GREEN LIGHTED PUSHBUTTON
-	ELV00-6000001	REPLACEMENT LIGHT BULB FOR BUTTON #15
16	NPYELLOW00139	NAMEPLATE
17	NPYELLOW00140	NAMEPLATE
19	ELP00-8800001	4 POSITION TURN SWITCH
20	NPYELLOW00137	NAMEPLATE
21	2EP00-8800006	2 POSITION TURN SWITCH
22	NPYELLOW00138	NAMEPLATE
23	ELP00-8800006	RED INDICATOR LIGHT
-	ELV01-2000002	REPLACEMENT LIGHT BULB FOR LIGHT #23
24	NPYELLOW00136	NAMEPLATE
25	NPRED0000019	NAMEPLATE
26	NPYELLOW00144	NAMEPLATE
27	NPRED00000141	NAMEPLATE
28	JCP07-00002	WINDOW, CONTROL COVER DOOR

IN ORDER TO MAINTAIN A HIGH QUALITY OF SERVICE:  
 1. WHEN ORDERING A PART HAVE THIS INFORMATION READY AS WELL AS THE PART NUMBER:  
 SITE NAME/LOCATION, UNIT SERIAL NUMBER AND UNIT VOLTAGE.  
 2. CLEVELAND RANGE RESERVES THE RIGHT TO CHANGE ANY PART NUMBER WITHOUT NOTICE.

**SERIAL# WWWW**  
**DRAWING# B600175**

**Tumble Chiller Cook Tank, Control Box, Internal (208V)**

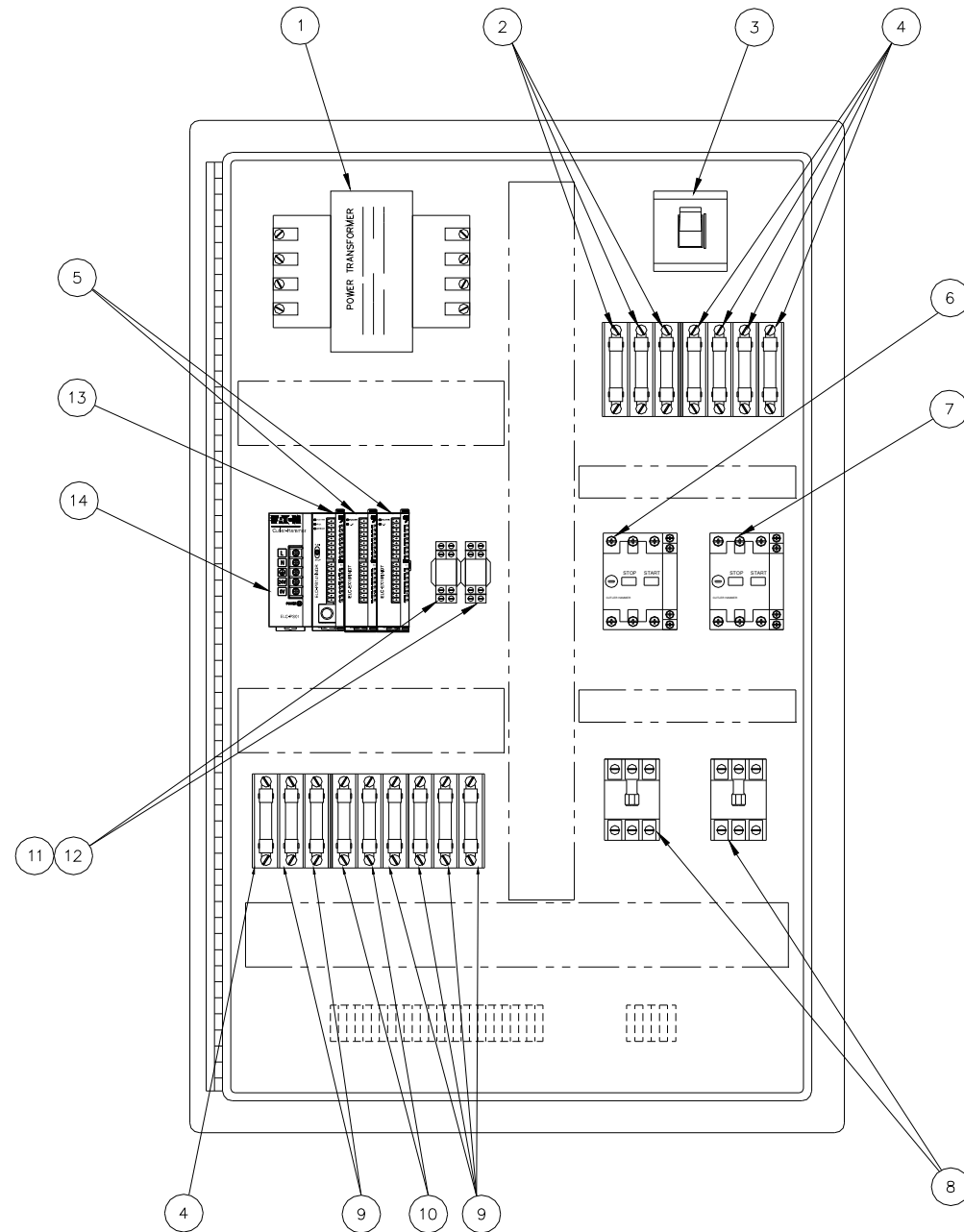

REPLACEMENT PARTS		
ITEM	PART NO.	DESCRIPTION
1	ELV05-000003	TRANSFORMER, 500VA
2	ELV06-000016	15 AMP FUSE
3	ELPSW-0000083	3 POLE SWITCH
4	ELV06-0000008	4 AMP FUSE
5	EL8CO-0000090	EXPANDER MODULE
6	ELPSW-0000096	MOTOR PROTECTOR
7	ELPSW-0000097	MOTOR PROTECTOR
8	ELPSW-0000095	MOTOR CONTACTOR
10	ELV02-5000015	2 AMP FUSE
9	ELV02-5000002	1 AMP FUSE
11	ELSPW-0000002	RELAY
12	ELPSW-0000003	RELAY HOLDER
13	EL8CO-0000085	PROGRAMMABLE CONTROLLER
14	EL8CO-0000089	POWER SUPPLY, 24V

IN ORDER TO MAINTAIN A HIGH QUALITY OF SERVICE:  
 1. WHEN ORDERING A PART HAVE THIS INFORMATION READY AS WELL AS THE PART NUMBER:  
 SITE NAME/LOCATION, UNIT SERIAL NUMBER AND UNIT VOLTAGE.  
 2. CLEVELAND RANGE RESERVES THE RIGHT TO CHANGE ANY PART NUMBER WITHOUT NOTICE.

**SERIAL# WWWW**  
**DRAWING# B600176**

**Glycol Reservoir - (208V-3PH-60HZ)**

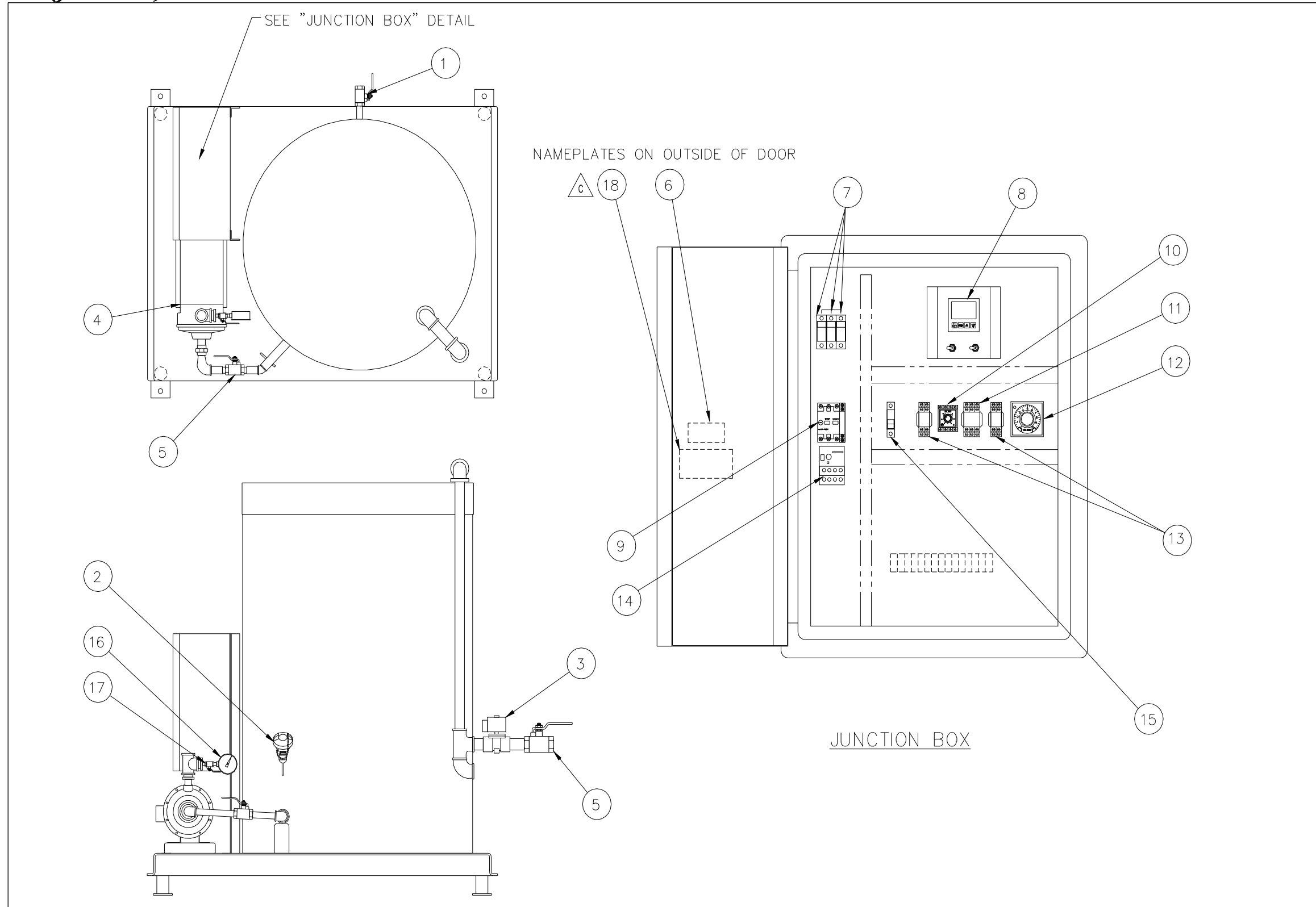

**SERIAL# XXXX**  
**Drawing# B6000013**

**Glycol Reservoir - (208V-3PH-60HZ) – (continued)**

**GLYCOL FLUID USED:  
 30% DOWFROST HD  
 (AN INHIBITED PROPYLENE  
 GLYCOL HEAT TRANSFER  
 FLUID) OR EQUAL**

**FAILURE TO USE THIS FLUID  
 MAY DAMAGE THE SYSTEM**

REPLACEMENT PARTS			
ITEM	PART NO.	DESCRIPTION	
	1	MSB01-0000002	MANUAL BALL VALVE
	2	TSENSOR00015	TEMPERATURE SENSOR
	-	MSFLUIDS00003	HEAT SINC. COMPOUND
	-	TSENSOR00016	THERMOWELL, REPLACEMENT
△ B	3	ELB01-5000001	SOLENOID
	-	SP999-9900003	REPAIR KIT
△ B	-	SP988-8800001	REPLACEMENT COIL
	4	ELH05-0000021	PUMP, CIRCULATING, 208/460V
	-	ELH05-0000022	MOTOR, 208V, REPLACEMENT
	-	SP999-9900090	REPAIR KIT, SEAL
	5	MSB01-5000007	BALL VALVE
	6	NPRED0000019	WARNING TAG
△ B	7	ELV06-0000022	FUSE, FNQR 20A, (208 VOLTS)
	8	EL8CO-0000088	TEMPERATURE CONTROLLER
	9	ELPSW-0000085	PUMP CONTACTOR
	10	EL8CO-0000017	TIMER
	-	ELP00-0000006	BASE
	11	ELPSW-0000014	RELAY
	-	ELPSW-0000015	BASE
	12	EL8CO-0000065	TIMER
	-	ELP00-0000042	BASE
	13	ELPSW-0000002	RELAY
	-	ELPSW-0000003	BASE
△ C	14	ELPSW-0000098	MOTOR OVERLOAD
	15	ELV06-0000019	FUSE, FNQR 5A
	16	AR800-2500019	GAUGE
△ C	17	MSB00-2500001	BALL VALVE
	18	NPRED0000039	WARNING TAG, DUAL VOLTAGES

- IN ORDER TO MAINTAIN A HIGH QUALITY OF SERVICE:
1. WHEN ORDERING A PART HAVE THIS INFORMATION READY AS WELL AS THE PART NUMBER:  
 SITE NAME/LOCATION, UNIT SERIAL NUMBER AND UNIT VOLTAGE.
  2. CLEVELAND RANGE RESERVES THE RIGHT TO CHANGE ANY PART NUMBER WITHOUT NOTICE.
  3. **OBsolete items are available as replacement parts but are no longer used in current production models.**

**SERIAL# XXXX**  
**Drawing# B6000013**

## Appendices

### Appendix A: Basic Trouble Shooting Tumble Chiller Cook Tank Serial #WWWW

Problem	Possible Cause	Remedy
Will not Power ON	1. No input power	1. Check main power disconnect and/or breakers.
	2. Blown Fuses	2. Check fusing and replace accordingly
Will not fill with water	1. No water pressure	1. Ensure the water source is turned on
	2. Valve not opening	2. Check indicator light on solenoid valve, also check corresponding output light on PLC, rebuild or replace if necessary
	3. Level sensor fouled	3. Check/clean/replace level sensor.
Rotating Basket/Drum will not turn (Note: Lid must be closed)	1. Lid Sensor	1. Check proximity sensor, adjustment might be required.
	2. Blown Fuses	2. Check for blown fuses
	3. Bad Contactor	3. Check and replace if necessary
Will not heat	1. No Steam	1. Check steam supply
	2. Valve not opening	2. Check indicator light on solenoid valve, also check corresponding output light on PLC, rebuild or replace if necessary.
Will not Cool	1. No Cooling water	1. Check cooling water supply
	2. Valves not opening	2. Check indicator light on solenoid valve, also check corresponding output light on PLC, rebuild or replace if necessary.
	3. Circulating pump not running	3. Check fusing and replace accordingly
	4. Clog in cooling lines or heat exchanger	4. Check inline strainer screens and heat exchanger for clogs. Back flush if needed.
Basket stops in non-top dead center position	1. Proximity sensor out of adjustment	1. Adjust the sensor position.
Chart Recorder	1. Not documenting	1a. Check Pens for Ink
		1b. Check temperature probe conductivity
		1c. Check for damage caused by water
Tank Water @40°F	1. Not lighting	1. Check Bulb
Emergency Stop switch	1. Not lighting	1. Check Bulb

**Appendix B: Basic Trouble Shooting Glycol Reservoir**  
**Serial# XXXX**

Problem	Possible Cause	Remedy
Will not Power ON	1. No input power	1. Check main power disconnect and/or breakers.
	2. Blown Fuses	2. Check fusing and replace accordingly
Circulating Pump not running	1. Bad contactor or fuses	1. Check Contactor and Fuses
	2. Temperature sensor not working	2. Check temperature sensor for conductivity-check wires and connection points-check for adequate heat transfer paste in thermo well, replace if necessary
	3. Bad/incorrectly adjusted timer	3. Check timer setting and operation.
	4. Temperature controller error	4. Check temperature controller setting and program parameters
Will not maintain glycol temperature at set point in reservoir	1. Glycol level to low	1. Check glycol level, fill to within 4" of top if necessary with appropriate glycol mix.
		1.1. Check for leaks in the system and supply/return lines.
	2. Temperature controller error	2. Check temperature controller setting and program parameters
	3. Temperature sensor not working	3. Check temperature sensor for conductivity-check wires and connection points-check for adequate heat transfer paste in thermo well, replace if necessary
4. Bypass solenoid not opening	4. Check for proper solenoid operation, check din connector, and wire connections	

**Appendix C: Basic Trouble Shooting 20 Ton Air Chiller**  
**Ser# ZZZZ**

Problem	Possible Cause	Remedy
For all problems	See Operations Manual for Air Chiller	See Operations Manual for Air Chiller

## Appendix D: Component Data Sheets

### 1. Watts Electric Motor Valve

# Series EMVII-6400SS

## Sizes: 1/4" - 1 1/2" (8-40mm) Electric Motor Valves

### Installation, Operation and Maintenance Manual

#### Description:

The Watts EMVII-6400SS motor valve is an electrically actuated standard port bronze ball valve with 316 stainless steel ball and stem.

For 1/4" - 1 1/2" (8-40mm) the actuator utilized is a unidirectional type with a NEMA 4 enclosure, featuring a shaded pole motor with a 25% duty cycle rating, hardened steel gear train and an extended male output shaft for manual override. The installation section of this manual is broken into two parts 1-valve and 2-electrical.

Prior to installation it is important to familiarize yourself with both sections so that the unit is properly installed.

#### Valve Installation

- A.** The stem seals on your EMVII-6400SS valve may require periodic adjustment during its' normal service life, therefore installations that prevent access to the valve for maintenance must be avoided. Further, it is important to understand that no valve's stem seals will function indefinitely. Eventually stem seals will require adjustments. At this point the external leakage would start off as a slight seepage and if left unattended could become significant.
- B.** All Watts EMVII-6400SS's utilize bidirectional valves and as such, can be installed to shut off flow in either direction.
- C.** When piping up the valve be sure that the threads on the mating pipe are free of excessive grit, dirt or burrs. Take care to assure that any pipe sealants used are not so excessively applied to the pipe threads that the valve cavity becomes fouled.
- D.** The unit can be installed with the actuator portion in either the vertical or horizontal plane, however for steam or high temperature applications see Section E.
- E.** For installations for steam or other high temperature services your Watts EMVII-6400SS features an electric actuator with a maximum ambient temperature rating of 150°F. (65.6°C) Higher temperatures will result in a significant reduction of the duty cycle rating and/or damage to electrical components.

Some steam or other high temperature applications may require that the actuator be installed horizontal to the pipe (on horizontal piping) to protect the unit from radiant heat. All piping in which units are installed and any adjacent piping must be insulated to further reduce the effects of piping radiant heat.

#### Electrical Installation

NOTE: Prior to making wiring connections, be sure that all external wiring and electrical components have been properly selected to suit the power consumption levels of your particular unit.

**Table 1 - Power Consumption**

VALVE SIZE		VOLTAGE AND CYCLE TIME	MAX AMPERAGE DRAW
in.	mm		
1/4 - 1 1/2	8 - 40	115 VAC-8 Second	1.6
1/4 - 1 1/2	8 - 40	115 VAC-35 Second	0.5
1/4 - 1 1/2	8 - 40	24 VAC-40 Second**	2.2

\*\* Requires min 40 VA Transformer.

**Note:** Not all voltage/cycle time combinations are available for every valve size. For specific model combinations consult your Watts distributor or representative.

#### Sizes: 1/4" - 1 1/2" (8 - 40mm)

- 1.** Your Watts EMVII-6400SS is provided with a total of six (6) functional terminal connections within the unit. Terminal numbers 1, 2, and 3 are connections for the internal SPDT auxiliary switch, while terminal numbers 4, 5, and 6 are provided for the operation of the valve.
- 2.** As shipped from the factory the actuator has been mounted in a mode that makes circuit 4 and 5 the "open valve" circuit and circuit 5 and 6 the "closed valve" circuit. Note that terminal 4 feeds the open limit switch, terminal 5 is the motor common and terminal 6 feeds the close limit switch.

**Warning:** Inadvertent application of power between terminals 4 and 6 will burn out the switches. Before application of power always recheck your terminal connections.

- 3.** To test the actuator:
  - a. Replace actuator cover before application of power.
  - b. Apply power to terminals 4 and 5 and observe for a "**Fully Open**" valve.
  - c. Apply power to terminals 5 and 6 and observe for a "**Fully Closed**" valve.
  - d. If valve operation is out of phase to your command signal; meaning if your external control wiring issues an "**Open Valve**" command and the unit closes, simply reverse your terminal 4 and 6 connection.
  - e. If your unit fails to fully open and/or fully close, check switch setting and, if required, reset switches per the instructions contained in subsequent sections of this manual.

## Maintenance

During its' normal service life the only maintenance that may be required by your EMVII-6400SS should be periodic stem seal adjustment. It is important that stem seal leaks to not go unattended as failure to adjust stem packing could significantly reduce seal life.

To adjust stem seals, simply tighten the stem gland nut. **Do not Over Tighten**, as in doing so you may over-compress stem seals which could result in excessive stem seal loading and reduction of seal life.

## IV. Switch Setting (Travel Limits)

### A. 1/4" - 1 1/2" (8 - 40mm)

1. As stated earlier in this manual, your unit is supplied with 6 functional terminal connections. Terminals 4, 5, and 6 are provided for rotational travel limits of the actuator. Terminal 5 is common. Application of power between terminal 4 and 5 will open the valve, while powering between terminal 5 and 6 will close the valve.
2. On all 1/4"-1 1/2" (8 - 40mm) models the actuator utilizes a one piece camshaft, therefore, setting one switch will set all three.
3. Viewing the actuator from the top, note that the **Top** switch (aux) ties into terminals 1, 2, and 3, the **Middle** switch ties into terminals 4 and 5 (open circuit) and the **Bottom** switch ties into terminals 5 and 6 (close circuit).
4. To set all 3 circuits:
  - a. Disconnect power supply
  - b. Remove actuator cover
  - c. Place valve in its' fully open position
  - d. Loosen camshaft retaining screw
  - e. Using the middle switch detent, rotate the camshaft until the middle switch arm drops into the middle cam detent
  - f. Retighten the camshaft retaining screw
  - g. Reinstall cover
  - h. Recheck all wiring connections prior to testing the unit.

## Operational Characteristics and Ratings

1. Valve type - Quarter turn ball valve, bronze body, 316SS ball and stem, reinforced Teflon® seats, standard port.
2. **Valve Ratings:** 1/4"-1 1/2" (8 - 40mm) 600psi WOG (41.9 bar); 100psi (6.9 bar) WSP
3. **Valve end connections:** All sizes NPTF.
4. **Max. actuator ambient temperature rating:** 150°F (65.6°C).
5. **Max. amperage rating of aux. switch:** 10 AMPS @ 115 VAC.

**Table 2**

VALVE SIZE		
in.	mm	Cv
1/4 - 3/8	8, 10	6.3
1/2	15	9.0
3/4	20	24.5
1	25	33.5
1 1/4	32	45.5
1 1/2	40	73.0

**Table 3 - Steam Flow (#hr) - Full Open Valve**

VALVE SIZE		10 psi INITIAL		15 psi INITIAL		25 psi INITIAL	
		1psi ΔP	10psi ΔP	1psi ΔP	15psi ΔP	1psi ΔP	25psi ΔP
1/4 - 3/8	8, 10	92	197	142	218	255	349
1/2	15	131	282	203	311	365	498
3/4	20	358	767	551	848	992	1355
1	25	358	767	754	1159	1357	1853
1 1/4	32	358	767	1024	1574	1843	2516
1 1/2	40	358	767	1643	2526	2957	4037

### Sample Installation #1

Use of Watts Electric Motor Valve as a zone control for hot water or steam space heating. Valve opens upon temperature drop. Closes when demand for heat is satisfied.

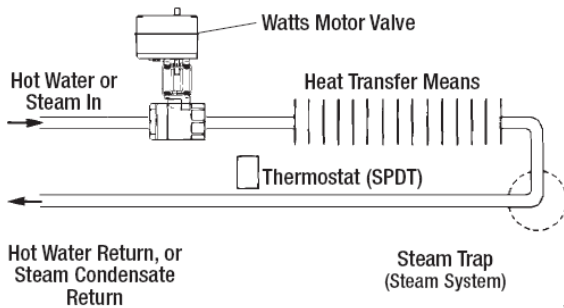

### Wiring Diagram #1

1/4" - 1 1/2" (8 - 40mm)

Electrical diagram with 24V control circuit, 24V Motor Valve, SPDT thermostat.

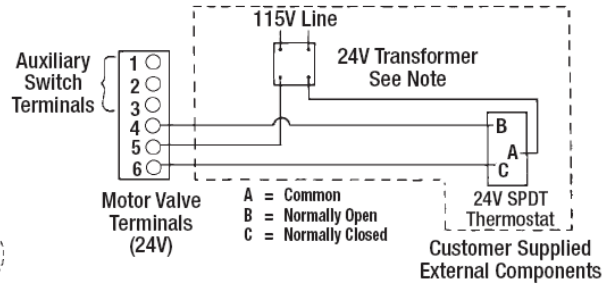

**Note:** 1/4"-1 1/2" (8 - 40mm) EMVII-6400SS-24-45 will operate with a 40 VAC transformer. Thermostat must be capable of handling amp rating at stall (see page 2 - Operating Data) or relay must be added to circuit.

### Sample Installation #2

Cooling with refrigerated water and operating forced air fan with auxiliary switch. Motor Valve opens and starts blower upon temperature rise. Shuts off blower and closes when temperature drops to thermostat setting.

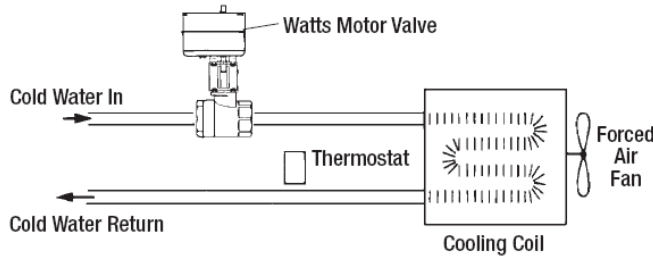

### Wiring Diagram #2

1/4" - 1 1/2" (8 - 40mm)

Electrical diagram with 115V control circuit, 115V Motor Valve, line voltage SPDT cooling thermostat, 115V blower.

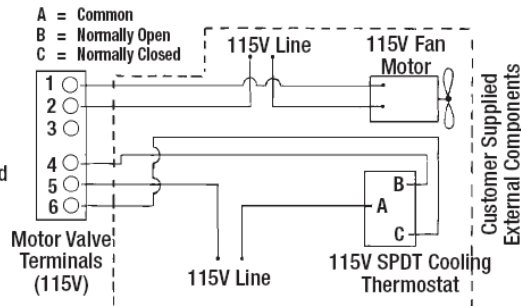

### Terminal Function 1/4" - 1 1/2" (8 - 40mm)

1/4"-1 1/2" (8 - 40mm) motor valves are supplied with wiring terminal strips having six terminals. Terminals 4, 5 and 6 operate the motor valve, while terminals 1, 2 and 3 are connected to an internal SPDT auxiliary switch.

**Note:** 24 VAC or 115 VAC models, the following terminal explanation will always apply.

Terminal No.	Function
Operating Terminal #4	When power is applied, valve will open
Operating Terminal #5	Common
Operating Terminal #6	When power is applied valve will Close
Auxiliary Switch Terminal #1	Makes when valve opens
Auxiliary Switch Terminal #2	Common
Auxiliary Switch Terminal #3	Makes when valve closes

**CALIFORNIA PROPOSITION 65 WARNING**

**WARNING:** This product contains chemicals known to the State of California to cause cancer and birth defects or other reproductive harm. (California law requires this warning to be given to customers in the State of California.)

For more information: [www.watts.com/prop65](http://www.watts.com/prop65)

**Limited Warranty:** Watts Regulator Co. (the "Company") warrants each product to be free from defects in material and workmanship under normal usage for a period of one year from the date of original shipment. In the event of such defects within the warranty period, the Company will, at its option, replace or recondition the product without charge.

**THE WARRANTY SET FORTH HEREIN IS GIVEN EXPRESSLY AND IS THE ONLY WARRANTY GIVEN BY THE COMPANY WITH RESPECT TO THE PRODUCT. THE COMPANY MAKES NO OTHER WARRANTIES, EXPRESS OR IMPLIED. THE COMPANY HEREBY SPECIFICALLY DISCLAIMS ALL OTHER WARRANTIES, EXPRESS OR IMPLIED, INCLUDING BUT NOT LIMITED TO THE IMPLIED WARRANTIES OF MERCHANTABILITY AND FITNESS FOR A PARTICULAR PURPOSE.**

The remedy described in the first paragraph of this warranty shall constitute the sole and exclusive remedy for breach of warranty, and the Company shall not be responsible for any incidental, special or consequential damages, including without limitation, lost profits or the cost of repairing or replacing other property which is damaged if this product does not work properly, other costs resulting from labor charges, delays, vandalism, negligence, fouling caused by foreign material, damage from adverse water conditions, chemical, or any other circumstances over which the Company has no control. This warranty shall be invalidated by any abuse, misuse, misapplication, improper installation or improper maintenance or alteration of the product.

Some States do not allow limitations on how long an implied warranty lasts, and some States do not allow the exclusion or limitation of incidental or consequential damages. Therefore the above limitations may not apply to you. This Limited Warranty gives you specific legal rights, and you may have other rights that vary from State to State. You should consult applicable state laws to determine your rights. **SO FAR AS IS CONSISTENT WITH APPLICABLE STATE LAW, ANY IMPLIED WARRANTIES THAT MAY NOT BE DISCLAIMED, INCLUDING THE IMPLIED WARRANTIES OF MERCHANTABILITY AND FITNESS FOR A PARTICULAR PURPOSE, ARE LIMITED IN DURATION TO ONE YEAR FROM THE DATE OF ORIGINAL SHIPMENT.**

**WATTS®**

Water Safety &amp; Flow Control Products

**ISO 9001-2000  
CERTIFIED**USA: 815 Chestnut St., No. Andover, MA 01845-6098; [www.watts.com](http://www.watts.com)Canada: 5435 North Service Rd., Burlington, ONT. L7L 5H7; [www.wattscanada.ca](http://www.wattscanada.ca)

IS-EMV-II 1/4"-1 1/2" 0845

EDP# 1921336

© Watts, 2008

## Series B6800 INSTALLATION, OPERATION and REPAIR MANUAL

IS-B6800

### A. INSTALLATION

#### I. Threaded-end (B6800):

1. The above listed standard valves are bidirectional and as such, can be installed for flow in either direction.
2. When installing threaded-end valves, be sure that the threads on the mating pipe are free from excessive grit, dirt or burrs. Take care to assure that any pipe sealants used are not so excessively applied to the pipe threads that the valve cavity becomes fouled.

#### II. Sweat-end (B6801, B6802): To protect seats and seals from high temperatures encountered while soldering, these valves must be disassembled prior to soldering.

#### B6800 Series

1. Remove body center section from adapters by removing one body bolt and loosening others.
2. Solder end adapters onto copper tubing system, orienting adapters to required valve position. One of the two adapter/ tubing assemblies must allow rotation to match alternate adapter bolt pattern.
3. After soldering and cool-down, install body assembly using new body seals provided and re-torque bolts as follows: (Use sequence shown on back page).

**TABLE 1**

**Series B-6800**

Valve Size	Body Bolt Torque (in.-lbs.)
1/4", 3/8", 1/2"	30 ± 5
3/4"	100
1"	200
1 1/4"	200
1 1/2"	300
2"	400

### B. VALVE OPERATION

1. All series Watts ball valves feature 1/4 turn operation. Turning the valve handle 90° clockwise will fully close the valve while a 90° counterclockwise rotation will fully open the valve. The valve handle also serves as a ball orifice position indicator. When the valve handle is parallel to the pipe, the valve is open, when perpendicular to the pipe, the valve is closed.
2. All series Watts ball valves are designed to provide optimum bubble-tight performance when properly selected in accordance with the valve's pressure/temperature rating, unless otherwise noted in seat material selection chart.
3. To provide the longest possible service-life, a hand-operated ball valve should be operated in either its' fully open or fully closed position. If an intermediate operating position is to be utilized, consult your Watts agent. Excessive pressure drops could adversely affect service life of the valve.
4. All Watts valves are factory assembled using an F.D.A. approved lubricant. Valves can be ordered from the factory without lubricant. The standard factory lubricant can be removed, if objectionable, by disassembling the valve and solvent washing.
5. The below listed torques are the normal expected maximum break-away torques. These values represent the force required to begin to open the valve. Typically, this break-away value is the maximum torque requirement of the valve during a closed to open, opened to closed cycle. Bear in mind that these values have been confirmed by laboratory testing of each valve while pressurized with water to the valve's maximum pressure rating. Certain highly viscous or abrasive services could cause an increase in torque requirements.

### C. MAINTENANCE

During its' service life, the only maintenance that may be required by your Watts ball valve should be periodic stem seal adjustment. If leakage at the stem is noted, simply tighten the valve stem gland nut until leakage subsides. It is impractical to predict frequency of stem adjustment as it is influenced by such factors as frequency of cycling and service media.

**IMPORTANT:** As is the case with any valve on the market today, it is important that stem leaks do not go unattended. Lack of maintenance of stem leakage could cause a premature need to replace stem seals. **NOTE:** If operating temperature of system is substantially lower or higher than 80°F, initial stem packing adjustment may be required to prevent leakage.

### D. REBUILDING

**WARNING:** Most standard bidirectional ball valves available on the market today, regardless of manufacturer, can trap fluids in the valve cavity when closed. If your Watts ball valve has been used to conduct hazardous media, the following steps should be taken **prior** to removal from line and disassembly.

**D. REBUILDING (cont'd)**

1. Relieve line pressure.
  2. Place the valve in a half-open position and flush the line to remove hazardous material from the cavity. The valve can now be removed from the line.
- NOTE:** Always advise maintenance personnel when they are maintaining or rebuilding a valve that has been conducting hazardous material. Proper protective clothing and eye protection should always be utilized.
3. To replace seats and seals:
    - a. For 6800 series, remove 1 top bolt, loosen other 3 body bolts, slide body center section out.
    - b. Once the center section has been removed, close the valve and remove the seats, ball and body seals. **NOTE:** If condition of the ball surface allows for its reuse, be careful to handle and store the ball in such a manner so as to prevent subsequent damage to the ball's critical surfaces.
    - c. Remove valve handle nut, handle, gland packing nut and remove the valve stem through the body cavity.
    - d. Remove the stem thrust-washer from the stem or the valve body cavity, if the washer did not come free from the cavity with the stem. Remove stem seal.
    - e. Examine all metallic sealing surfaces such as ball, stem shank and pipe-ends for damage such as scratches or nicks. In some cases, slight scratches across the sealing surface of pipe ends can be removed using a light emery cloth. If pipe end damage is excessive, the **valve** must be replaced. If the ball or stem is excessively damaged, ball and stem kits can be ordered. Consult your Watts agent.
    - f. Having assured that all critical surfaces have been inspected, cleaned and/or replaced, reassembly can begin.
    - g. Place new thrust-washer on stem and install stem through body cavity. Place new stem seal in position. Reinstall gland nut and tighten to the torque listed on Table 2.
    - h. Lightly lubricate seats and body seals using a lubricant that is compatible for the service media.
    - i. Reinstall ball, seats and body seals.
    - j. Reinstall center section between pipe-ends and retighten bolts in torquing sequence shown to the values listed on Table 1.
    - k. Reinstall handle and secure with handle nut.

**TABLE 2**  
**Packing Nut Torques**

**Series B-6800**

Valve Size	Torque (in.-lbs.)
1/4", 3/8", 1/2"	25-60
3/4"	30-60
1"	180-300
1 1/4"	200-300
2"	300-350

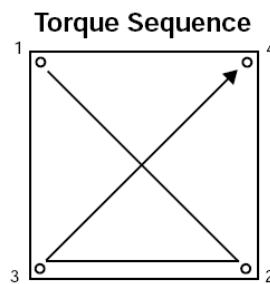

**MATERIALS**

- Handle Nut:** Plated carbon steel
- Handle:** Plated carbon steel with vinyl insulator
- Packing Nut:** Brass
- Stem Packing:** Glass reinforced TFE
- Thrust Washer:** Glass reinforced TFE
- Stem:** Brass
- Body:** Bronze
- Seats:** Glass reinforced TFE with Durafill
- Ball:** Hard chrome plated brass
- Adapters:** Bronze
- Body, Nuts, Bolts:** Cadmium plated carbon steel

**CALIFORNIA PROPOSITION 65 WARNING**

**WARNING:** This product contains chemicals known to the State of California to cause cancer and birth defects or other reproductive harm. (Installer: California law requires that this warning be given to the consumer.)

For more information: [www.wattsind.com/prop65](http://www.wattsind.com/prop65)



USA: 815 Chestnut St., No. Andover, MA 01845-6098; [www.wattsreg.com](http://www.wattsreg.com)  
 Canada: 5435 North Service Rd., Burlington, ONT, L7L 5H7; [www.wattscda.com](http://www.wattscda.com)



IS-B6800 0223

EDP# 1910641

**LIMITED WARRANTY:** Watts Regulator Company warrants each product against defects in material and workmanship for a period of one year from the date of original shipment. In the event of such defects within the warranty period, the Company will, at its option, replace or recondition the product without charge. This shall constitute the exclusive remedy for breach of warranty, and the Company shall not be responsible for any incidental or consequential damages, including without limitation, damages or other costs resulting from labor charges, delays, vandalism, negligence, fouling caused by foreign material, damage from adverse water conditions, chemicals, or any other circumstances over which the Company has no control. This warranty shall be invalidated by any abuse, misuse, misapplication or improper installation of the product. THE COMPANY MAKES NO OTHER WARRANTIES EXPRESS OR IMPLIED EXCEPT AS PROVIDED IN THIS LIMITED WARRANTY.

© Watts Regulator Co., 1996

Printed in U.S.A.

## 2. Dwyer Series 673 Pressure Switch



### SERIES 673 Pressure Transmitter

#### Specifications – Installation and Operating Instructions

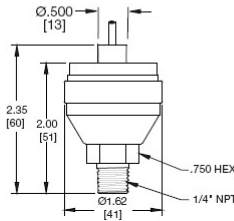

#### DESCRIPTION

The low cost Series 673 Pressure Transmitter is a fixed range transmitter designed for harsh environments and suitable for high shock and vibration applications. Constructed of stainless steel, the Series 673 provides a 4 to 20 mA output signal with 0.25% accuracy. Use the Series 673 in industrial OEM equipment, hydraulic systems, HVAC equipment, industrial engines and compressor control.

#### INSTALLATION

##### Electrical Connections

The Series 673 Pressure Transmitter is a true 2-wire, 4-20 mA current output device and delivers rated current into any external load of 0-800 ohms. The transmitter has a two wire cable where red is positive and black is negative. Connect shield to system or earth ground.

The 4-20 mA current output units are designed to have current flow in one direction only - please observe polarity. We suggest that the electrical cable shield be connected to the system's loop circuit ground to improve electrical noise rejection.

##### Media Compatibility

These transmitters are designed to be used with any gas or liquid compatible with 17-4 PH stainless steel.

##### Pressure Fitting

Typically, standard pipe fittings and procedures should be used. However, for pressure ranges in excess of 500 psig, we suggest the use of a sealant such as Loctite Hydraulic Sealant. Excessive torquing of metal fittings may cause a slight zero shift. The use of plastic fittings typically results in no noticeable zero shift. Torquing does not appreciably affect linearity or sensitivity.

#### MAINTENANCE/REPAIR

No routine maintenance is required on the Series 673 Pressure Transmitter. These units are not field repairable and should be returned to the factory if service is required. After first obtaining a Returned Goods Authorization (RGA) number, send the unit, freight prepaid to the following address. Please include a clear description of the problem plus any application information available.

Dwyer Instruments, INC.  
 Attn: Repair Department  
 102 Highway 212  
 Michigan City, IN 46360

#### PHYSICAL DATA

**Media Compatibility:** Liquid, gas or vapor.

**Accuracy:**  $\pm 0.25\%$  FS (RSS), (includes non-linearity, hysteresis and non-repeatability).

**Maximum Overpressure:**  $2 \times$  maximum range.

**Output:** 4-20 mA, 2-wire.

**Supply Voltage:** 9-30 VDC.

**Loop Resistance:** 0 to 800 $\Omega$ .

**Minimum Supply Voltage (VDC):**  $9 + 0.02 \times$  (Resistance of receiver plus line).

**Maximum Supply Voltage (VDC):**  $30 + 0.004 \times$  (Resistance of receiver plus line).

**Response Time:** <60 msec.

**Stability:** 0.5% FS/year.

**Shock (Mil-Std. 202, Method 213B, Cond. C):** 200g.

**Vibration (Mil-Std. 202, Method 204, Cond. C):** 20g.

**Operating Temperature Range:** -40 to 260°F (-40 to 125°C).

**Storage Temperature Range:** -40 to 260°F (-40 to 125°C).

**Compensated Temperature Range:** 4 to 212°F (-20 to 100°C).

**Thermal Error:** Zero:  $\pm 2.0\%$ FS/100°F (100°C); Span:  $\pm 1.5\%$ FS/100°F (100°C).

**Zero & Span Adjustment:** Fixed.

**Wetted Parts:** 17-4 PH Stainless Steel.

**Enclosure:** Stainless Steel and Valox.

**Electrical Connections:** 2 ft (61 cm) multiconductor cable.

**Pressure Connection:** 1/4" NPT(M).

**Weight:** 2.3 oz (65 g).

#### SERIES 673 PRESSURE TRANSMITTER MODELS

Model Number	Range	Model Number	Range
673-1	0 to 1 psi	673-6	0 to 50 psi
673-2	0 to 2 psi	673-7	0 to 100 psi
673-3	0 to 5 psi	673-8	0 to 200 psi
673-4	0 to 10 psi	673-9	0 to 500 psi
673-5	0 to 25 psi	673-10	0 to 1000 psi

**Appendix E: Component Manuals Supplied in addition to this manual**  
**Serial# WWWW**

1. MRC 8000 Installation, Wiring, Operation Manual.
2. Red Lion C48T Timer Instruction Manual (green).
3. Goulds Pumps, G&L Series, Model NPE/NPE-F, Installation, Operation and maintenance Instructions.
4. EATON, ELC-PS01, ELC-PS02 Power Supply Module, Instruction Sheet.
5. EATON, ELC-EX08NNDR/T, ELC-EX16NNDR/T, ELC-EX08NNDN, ELC-EX08NNAN, ELC-EX08NNNR/T, ELC-EX06NNNI, Digital Input Digital Output Module, Instruction Sheet.
6. EATON, ELC-PB14NNDR/T, Logic Controller with Slim, Multiple commands, Instruction Sheet.

**Serial# XXXX**

1. Goulds Pumps, G&L Series, Model NPE/NPE-F, Installation, Operation and maintenance Instructions.
2. Redlion, Models T48 & P48 Instruction Manual (White Book)
3. ATC, AT8 and AT11 Timers, Installation Instructions
4. Bulletin 193 E1 PLUS Overload Relay Application and Installation

**Appendix F: Component Programs**  
**1. Partlow 8000 Dual Pen Chart Recorder Program**  
**SERIAL# WWWW**

		<b>PROGRAM MODE</b>		
<b>STEP</b>	<b>DESCRIPTION</b>	<b>DISPLAY CODE</b>	<b>*C SETTING</b>	<b>*F SETTING</b>
1	Input Select	inPS	20 - 20	21 - 21
3	Output 1	out1	1 - 1	1 - 1
9	Alarm 1-Alarm point selected in Tune mode.	AL1	0 - 2	0 - 2
10	Alarm 2	AL2	0 - 0	0 - 0
11	Display Select	diSP	2 - 2	2 - 2
12	Decimal Position	dPoS	0 - 0	0 - 0
15	Hysteresis for Control Outputs	HyCo	1 - 1	1 - 1
16	Hysteresis for Alarm Outputs	HyAo	1 - 1	1 - 1
20	Setpoint Upper Limit	SPuL	110 - 110	230 - 230
21	Setpoint Lower Limit	SPLL	0 - 0	30 - 30
23	Process Rounding of Display & recorded value	Prnd	0 - 0	0 - 0
29	Chart Range Upper Value	Cru	150 - 150	230 - 230
30	Chart Range Lower Value	CrL	0 - 0	30 - 30
34	Relay A Assignment	rLyA	7	7
35	Relay B Assignment	rLyb	3	3
36	Relay C Assignment	rLyC	5	5
37	Relay D Assignment	rLyd	0	0
50	Chart Rotation Time	Crt	24	24

**TUNE MODE**

<b>STEP</b>	<b>DESCRIPTION</b>	<b>DISPLAY CODE</b>	<b>*C SETTING</b>	<b>*F SETTING</b>
2	Process alarm 1 (The Alarm setting seen will depend upon the Alarm selected in the Program Mode)	PAL1	4	40

**ENABLE MODE**

SEE PARTLOW 8000 MANUAL FOR DIRECTIONS ON HOW TO ACCESS THE ENABLE MODE AND HOW TO SET JUMPER TO ACCESS & LOCK ENABLE MODE.

<b>STEP</b>	<b>DESCRIPTION</b>	<b>DISPLAY CODE</b>	<b>*C SETTING</b>	<b>*F SETTING</b>
1	Test Mode	EtSt	oFF	oFF
2	Calibration	ECAL	oFF	oFF
3	Program Mode	EPro	oFF	oFF
4	Tune Mode	Etun	oFF	oFF
5	Manual (Stby) Mode	ESby	oFF	oFF
7	Setpoint Change	ESPC	on	on

**PROGRAMMING/CALIBRATION NOTES:**

1. SEE PARTLOW 8000 MANUAL FOR DIRECTIONS ON HOW TO PROGRAM THE UNIT.
2. TO PROGRAM THE UNIT THE PROGRAM MODE “EPro” MUST BE SET TO “ON” UNDER ENABLE MODE
3. INTERNAL JUMPERS MUST BE SET FOR “RTD” BEFORE PROGRAMMING UNIT.
4. TO CALABRATE THE PENS THE CALIBRATION “ECAL” MUST BE SET TO “ON” UNDER ENABLE MODE.
5. SET “ECAL” AND “EPro” TO “oFF” WHEN FINISHED PROGRAMMING/CALIBRATING.

**2. C48T Redlion Timer Program**  
**SERIAL# WWWW**

**60 & 100-TCCT MODEL C48T TIMER**

**USER SETTINGS CHART**

Entry	Numerica Value Entry Method	AutoSc
trAngE	Timer Range	h.n
OPeR	Timer Operating Mode	11
rStPuP	Timer Reset At Power- Up	no

<b>PRESETS</b>		<b>2 1</b>
Ac Prs	Access Preset Value	Y Not
PrESEt	Preset 1 Value	Used Not
PrESEt	Preset 2 Value (Dual Preset Only)	Used Not
PltrAc	P1 Track P2 (Dual Preset Only)	Used

<b>OUTPUTS</b>		
Ac Out	Access Output Time Values	L
OutrES	Output Resolution	0.1 sec Not
OutPut	Output 1 Time	Used Not
OutPut	Output 2 Time (Dual Preset Only)	Used
rEUOut	Reserse Relay/ Output Logic	N
rEURnu	Reverse Annunciator Logic	N
OutPuP	Output Power- up state	F

<b>USER INPUTS</b>		
USr In1	User Input 1	Not Used
USr In2	User Input 2	Not Used
USr In3	User Input 3	Not Used
USr F 1	User F1 Key	Not Used
CodE	Programming Code Value	0
ScroLL	Scroll Display	NO

**3. Redlion Temperature Controller Program**  
**SERIAL# XXXX**

**RESERVOIR TEMP CONTROLLER T48 FAHRENHEIT**

**UNIT NUMBER**

**CONFIGURE OUTPUT (2-OP)**

MNEMONIC	PARAMETER	USER SETTINGS	MNEMONIC	PARAMETER	USER SETTINGS
SP	Temperature Set point	50	CYct	Cycle Time	2
OPOF	Output Power Offset	N/A	OPAC	Control Action	drct
OP	Output Power	N/A	OPLO	Output Power Lower Limit Range	0
ProP	Proportional Band	0	OPHI	Output Power Upper Limit Range	100
Intt	Integral Time	N/A	OPFL	Sensor Fail Power Preset	0
dErt	Derivative Time	N/A	OPdP	Output Power Dampening ON/ OFF Control	3
AL -1	Alarm 1	95	CHYS	Hysteresis	16
AL -2	Alarm 2	N/A		Auto- Tune Dampening	
			tcod	Code	0
			ANtP	Linear Output Range	N/A
			ANAS	Linear Output Source	N/A
			ANUt	Linear Output Update Time	N/A
				Linear Output Scale Point	
			ANLO	Low	N/A
				Linear Output Scale Point	
			ANHI	High	N/A

**CONFIGURE INPUT (1-IN)**

**CONFIGURE LOCKOUTS (3-LC)**

MNEMONIC	PARAMETER	USER SETTINGS	MNEMONIC	PARAMETER	USER SETTINGS
tYPE	Input Sensor Type	r392	SP	Access Set point	LOCK
SCAL	Temperature Scale Units	F	OP	Access Output Power	LOCK
dCPt	Resolution	0	dEv	Access Deviation Display	LOCK
FLtr	Digital Filtering	1	Hcur	Access Heater Current	LOCK
SHFt	Input Offset	0	UdSP	Access Display Units	READ
SPLO	Set point Lower Limit	0	CodE	Access Code Number	0
SPHI	Set point Upper Limit	9999	PId	Access PIC Values	LOCK
SPrP	Ramp Rate	N/A	AL	Access Alarm(s) Valvues	LOCK
InPt	User Input	PLOC	ALrS	Enable Reset Alarm(s)	LOCK
				Enable Remote/ Local	
			SPSL	Transfer	LOCK
			turnF	Enable Auto/ Man Transfer	LOCK
			tUNE	Enable Auto- tune	LOCK

**CONFIGURE ALARMS (4-AL)**

**CONFIGURE REMOTE SETPOINT**

(NOT AVAILABLE)

**CONFIGURE HEATER CURRENT INPUT  
 (NOT AVAILABLE)**

MNEMONIC	PARAMETER	USER SETTINGS
Act1	Alarm 1 Operation Mode	A-LOW
rSt1	Alarm 1 Reset Mode	AUTO
Stb1	Alarm 1 Standby Enabled	NO
AL - 1	Alarm 1 Value	95
Act2	Alarm 2 Operation Mode	N/A
rSt2	Alarm 2 Reset Mode	N/A
Stb2	Alarm 2 Standby Enabled	N/A
AL - 2	Alarm 2 Value	N/A
AHYS	Alarm Hysteresis Value	15

**CONFIGURE COOLING  
 (NOT AVAILABLE)**

**CONTROLLER OPERATIN MODE  
 (NOT AVAILABLE)**

**RESERVOIR TEMP CONTROLLER T48 FAHRENHEIT  
PROGRAMMING INSTRUCTIONS**

1. FLIP THE SWITCH ON THE SIDE OF THE MOUNTING BRACKET UNTIL "SP, PROP, AL-1 & CNFP" APPEAR WHEN YOU PRESS THE "P" BUTTON.
2. THE SETTINGS FOR "SP" (TEMPREATURE SETPOINT), "PROP" (PROPORTIONAL BAND), AND AL-1 (ALARM 1) CAN BE SET FROM THIS AREA BY USING THE UP AND DOWN ARROW BUTTONS.
3. TO ACCESS THE NEXT FOUR (4) MENU AREAS PRESS THE "P" BUTTON UNTIL "CNFP" IS DISPLAYED. IT'S SETTING IS "NO"
4. USING THE "UP" ARROW BUTTON SCROLL TO "1-IN" THEN PRESS THE "P" BUTTON. "tYPE" SHOULD BE DISPLAYED WITH IT'S SETTING BELOW IT.
5. TO CHANGE IT'S SETTING USE THE UP AND DOWN ARROW BUTTONS. TO EXIT THIS OPTION AND ADVANCE TO THE NEXT SETTING PRESS THE "P" BUTTON. REPEAT THIS FOR EACH OPTION UNDER "1-IN". WHEN YOU HAVE SET THE LAST PARAMATER IN THIS SECTION CNFP" WILL APPEAR AGAIN FLASHING TO "NO" AND BACK.
6. USING THE "UP" ARROW BUTTON SCROLL TO "2-OP" THEN PRESS THE "P" BUTTON. "CYCt" SHOULD BE DISPLAYED WITH IT'S SETTING BELOW IT. SEE STEP 5 TO SET THE PARAMATERS IN THIS SECTION.
7. USING THE "UP" ARROW BUTTON SCROLL TO "3-LC" THEN PRESS THE "P" BUTTON. "SP" SHOULD BE DISPLAYED WITH its SETTING BELOW IT. SEE STEP 5 TO SET THE PARAMATERS IN THIS SECTION.
8. USING THE "UP" ARROW BUTTON SCROLL TO "4-AL" THEN PRESS THE "P" BUTTON. "Act1" SHOULD BE DISPLAYED WITH its SETTING BELOW IT. SEE STEP 5 TO SET THE PARAMATERS IN THIS SECTION.
9. AFTER SETTING THE PARAMATERS IN THESE 4 AREAS FLIP THE SWITCH BACK TO LOCKOUT THE PROGRAMMING MODE AGAIN. PRESSING THE "P" BUTTON A FEW TIMES WILL CLEAR THE PROGRAM OPTIONS AND DISPLAY THE CURRENT SETPOINT AND "F" OR "C". BELOW IT.

**Appendix G: ASME Code Compliance Documents**  
**SERIAL# WWWW**



American Society of Mechanical Engineers

**SEE FOLLOWING PAGES FOR ASME FORM U-1A**  
**(MANUFACTURE'S DATA REPORT FOR PRESSURE VESSELS)**



**Appendix H: SEW Eurodrive Drive Unit  
SERIAL# WWWW**

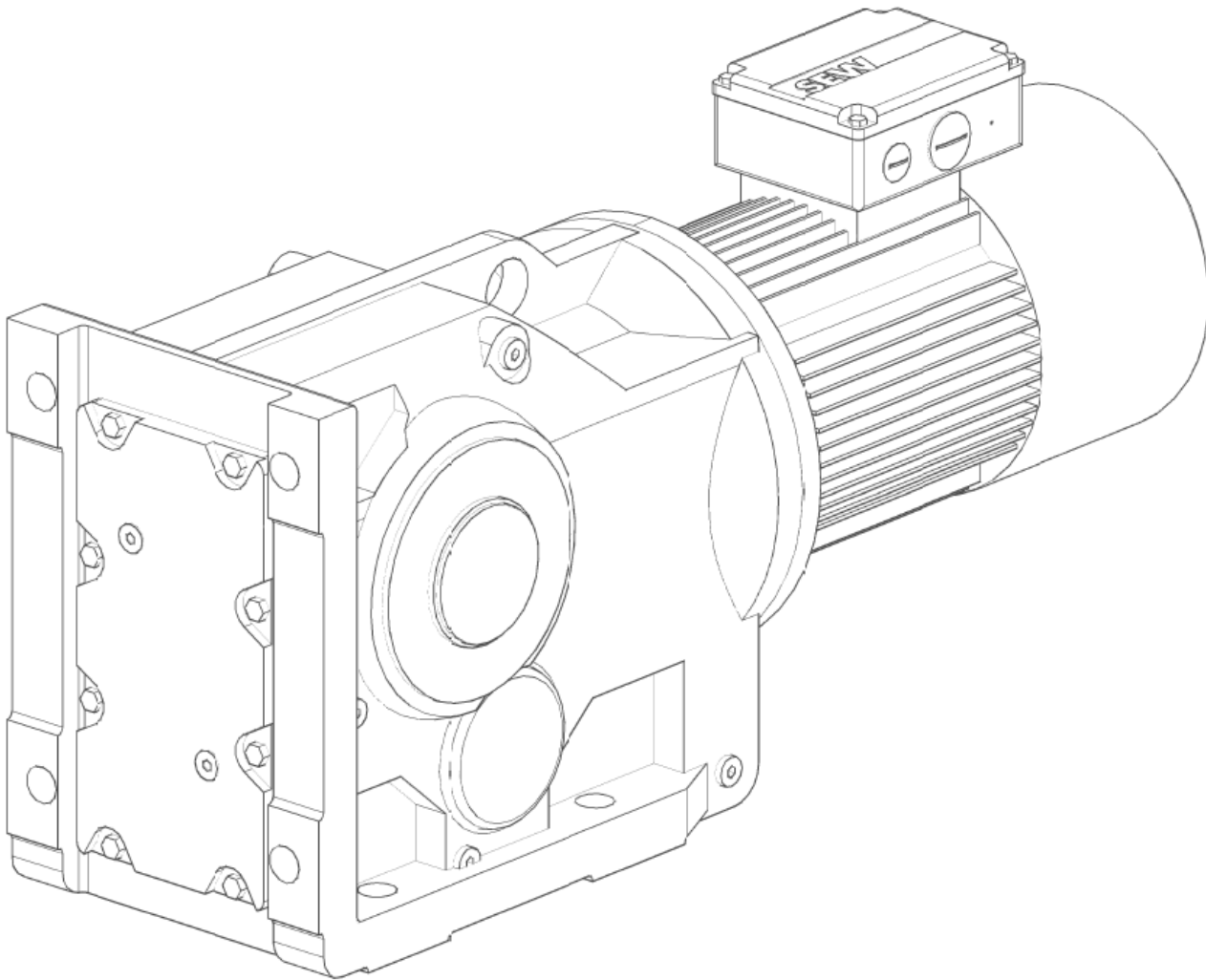

**SEE FOLLOWING PAGES FOR SEW EURODRIVE GENERAL SPECS/LUBRICATION  
DATA, ELECTRIC MOTOR, GEAR REDUCER, GEAR BOX SPEC SHEETS AND  
REPLACEMENT PARTS.**

**Appendix I: Factory Inspection and Test Paperwork**

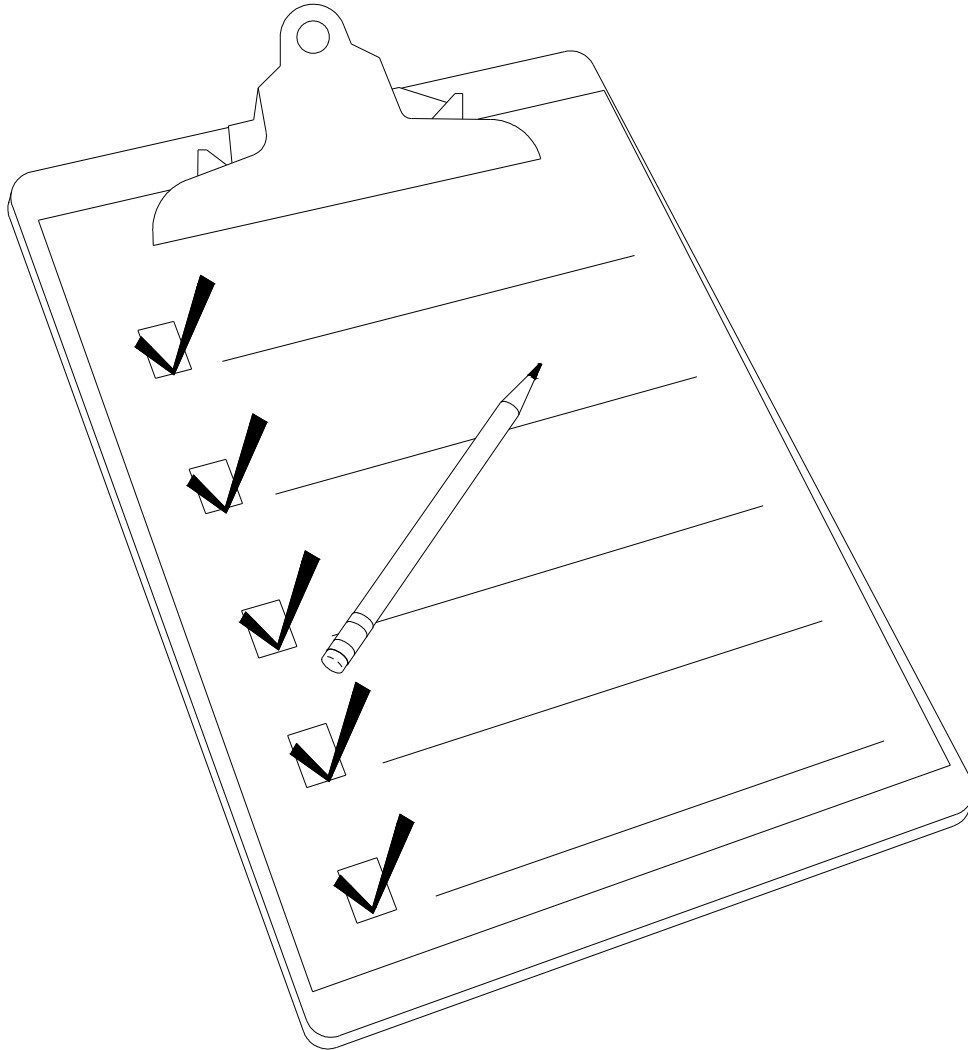

**SEE FOLLOWING PAGES FOR FACTORY  
TEST AND INSPECTION SHEETS**