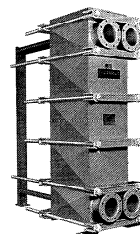
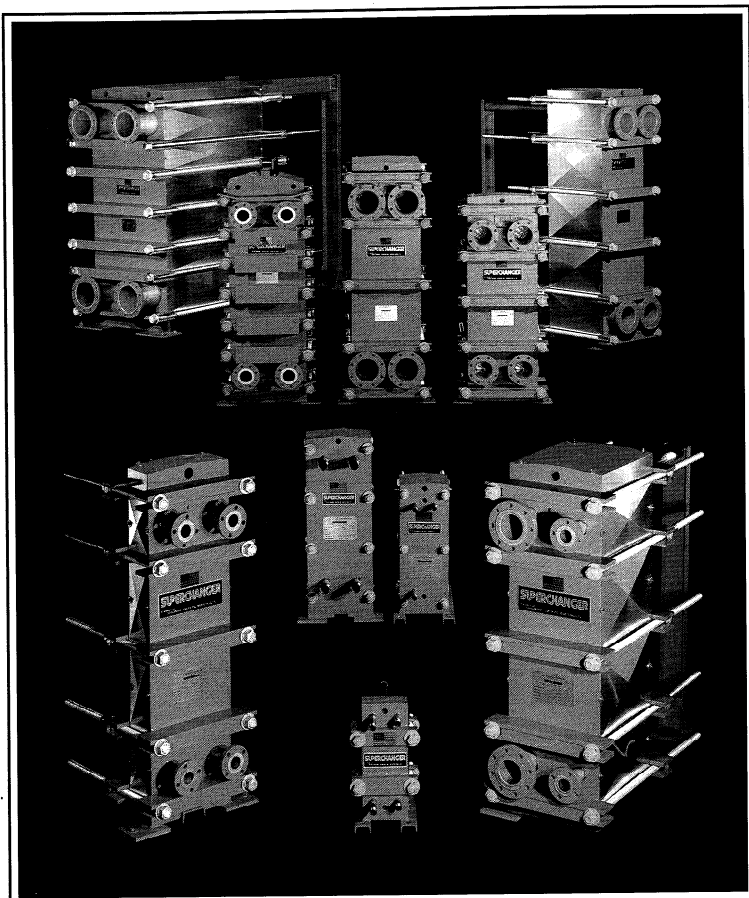


# Installation and Operation Manual



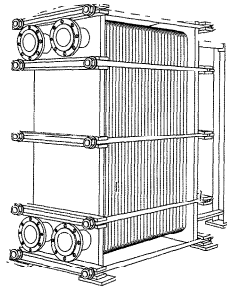
**SUPERCHANGER<sup>®</sup>**

P L A T E

&

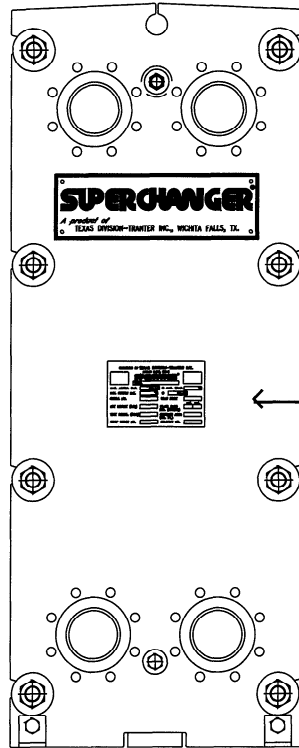
F R A M E

# Index




<b>General Description</b> . . . . .	1	<b>Installation</b> . . . . .	25	<b>Trouble-Shooting</b> . . . . .	40
<b>Identifying Your Superchanger Unit</b> . . . . .	1	Tightening the Plate Pack . . . . .	26	Leakage Between the Plate	
<b>Plate Description and Construction</b> . . . . .	2	Tightening Sequence . . . . .	27	Pack and the Frame . . . . .	41
Plate Details . . . . .	3	<b>Start-Up Procedures</b> . . . . .	27	Leakage Between the Nozzle	
Frame Pressure Ratings . . . . .	4	Precautions Prior to Start-Up . . . . .	27	and the End Frame . . . . .	41
Mixed Plate Units . . . . .	4	<b>Servicing</b> . . . . .	28	Leakage Between the Plates	
Plate Data . . . . .	5	Shutting Down the Unit . . . . .	28	to the Outside of the Unit . . . . .	42
Frame Dimensions . . . . .	6	Disassembly Procedures . . . . .	28	Mixing of Fluids . . . . .	42
Plate Pack Widths . . . . .	7	Removal of Plates . . . . .	29	Increase in Pressure Drop or a	
Plate Material and Date of		Replacing Plates . . . . .	29	Reduction in Temperature Readings . . . . .	43
Manufacture Data . . . . .	9	Replacing Gaskets . . . . .	30	<b>Storage Procedures</b> . . . . .	44
Plate Designations . . . . .	10	Continuous-Glued Gaskets . . . . .	31	<b>Miscellaneous Instructions</b> . . . . .	45
Element Composition Diagram . . . . .	11	Spot-Glued Gaskets . . . . .	32	General Maintenance . . . . .	45
<b>Pass and Flow Arrangement</b> . . . . .	13	Superlock Snap-In Gaskets . . . . .	34	Ordering Parts . . . . .	45
Plate Pass Arrangement . . . . .	13	Teflon Encapsulated Gaskets . . . . .	34	Returned Material . . . . .	46
Flow Arrangement . . . . .	14	<b>Cleaning</b> . . . . .	35	Damaged Shipments . . . . .	46
Drains . . . . .	14	Steps for Manual Cleaning of Plates . . . . .	36	Additional Information . . . . .	46
Connecting "C" Frames . . . . .	16	<b>Plate Cleaning Tips</b> . . . . .	37		
UFX Plate Design . . . . .	17	Cleaning-in-Place (CIP) . . . . .	37		
Plate Order . . . . .	21	Back Flushing and Strainers . . . . .	39		
<b>Gasket Data</b> . . . . .	22	Cleaning Guidelines . . . . .	39		
Gaskets—Glued . . . . .	22				
Gaskets—Glueless . . . . .	23				
Gasket Storage Procedures . . . . .	23				
Mixed Gasket Materials . . . . .	23				

# IDENTIFYING YOUR SUPERCHANGER<sup>®</sup> UNIT



A data plate like the one shown on the picture below is fixed to the stationary frame of the unit and provides the following information. This information is helpful when contacting the factory.

CERTIFIED BY TEXAS DIVISION-TRANTRER INC. WICHITA FALLS, TEXAS							
							
MODEL <input type="text"/>							
MAX. ALLOW. W.P.	<input type="text"/> P.S.I.G.	⊙ MAX. TEMP.	<input type="text"/> °F				
MIN. DESIGN M.T.	<input type="text"/> °F	⊙	<input type="text"/> P.S.I.G.				
SERIAL NO.	<input type="text"/>	YEAR BUILT	<input type="text"/>				
NET WEIGHT (LBS)	<input type="text"/>	PLATE PACK DIM. (INCHES)	<table border="1" style="display: inline-table;"> <tr> <td style="text-align: center;">MIN.</td> <td style="text-align: center;">MAX.</td> </tr> <tr> <td><input type="text"/></td> <td><input type="text"/></td> </tr> </table>	MIN.	MAX.	<input type="text"/>	<input type="text"/>
MIN.	MAX.						
<input type="text"/>	<input type="text"/>						
TEST PRESS. (PSIG)	<input type="text"/>	SURFACE AREA (SQ. FT.)	<input type="text"/>				
SHOP ORDER NO.	<input type="text"/>	DRAWING NO.	<input type="text"/>				

DATA PLATE

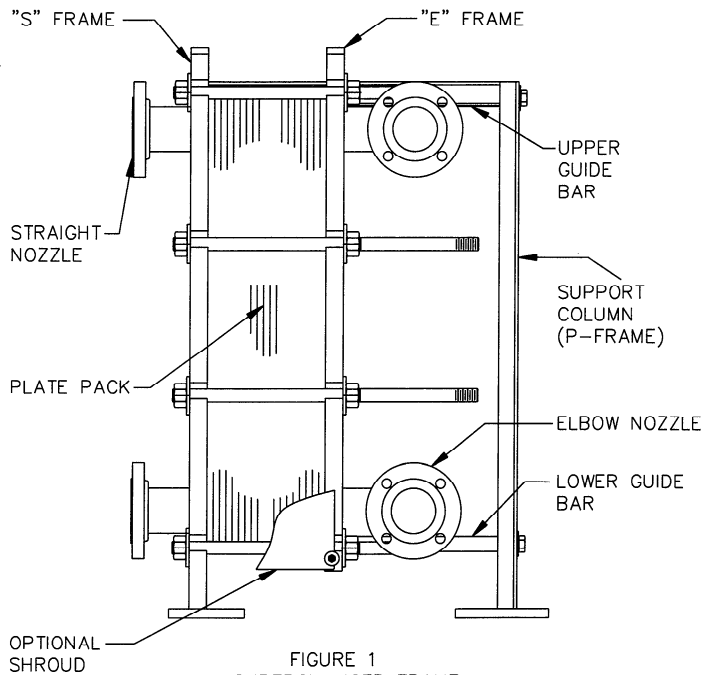


FIGURE 1  
SUPERCHANGER FRAME  
MODELS HP, UP, SP, MP, FP

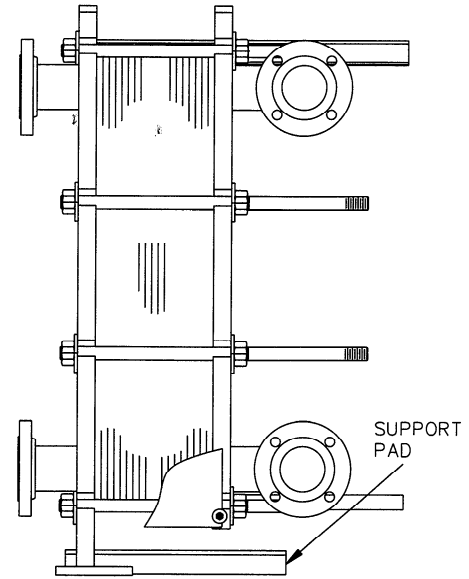


FIGURE 2  
SUPERCHANGER FRAME  
MODELS HJ, UJ, SJ, MJ

## PLATE DESCRIPTION AND CONSTRUCTION

SUPERCHANGER plate corrugations are available in four patterns. Depending on the applications, the S, UX, SX, M, GC, V, T, UFX, and TW series plates are used to achieve maximum heat transfer.

**S series plates:** Parallel (washboard) pattern is used in applications involving viscous type liquids and solutions.

**UX, SX, V, M, GC, and T series plates:** Herringbone (chevron) pattern is ideally suited for handling aqueous solutions.

**TW series:** Wide gap pattern is designed for applications where there are high viscosity fluids or fluids containing fibers or coarse particles.

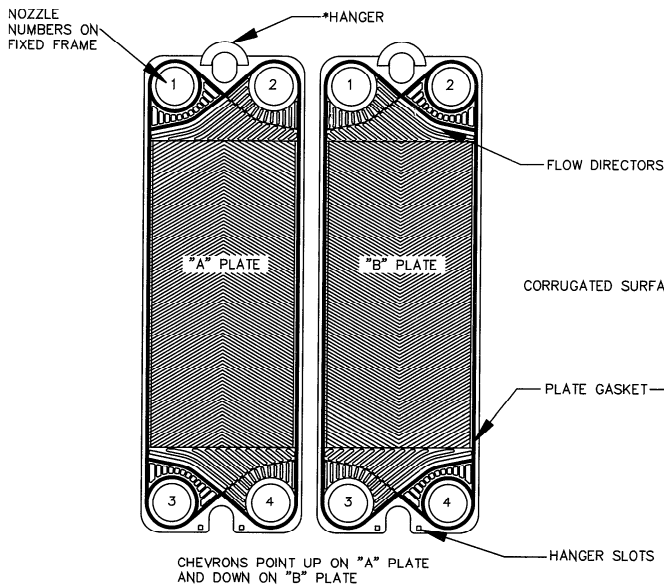
**UFX series:** An asymmetrical four quadrant plate suited for low viscosity and close temperature approach applications or processes involving two vastly different flow rates.

All plates are manufactured from die-formed sheet metal in virtually any material that can be cold worked, such as stainless steel, titanium, Alloy C-276, Alloy-20, etc. There are grooves around the circumference of the plates which accept the sealing gasket and also add reinforcement because of the ribbed edges. Fluid passage holes are pierced at the corners of each plate. The number and location of the holes is dependent upon the design conditions.

The gaskets are single piece, molded construction, and generally bonded to the plates with Pliobond 30 adhesive. The gasket material is selected for compatibility with the fluids being processed and the operating temperatures.

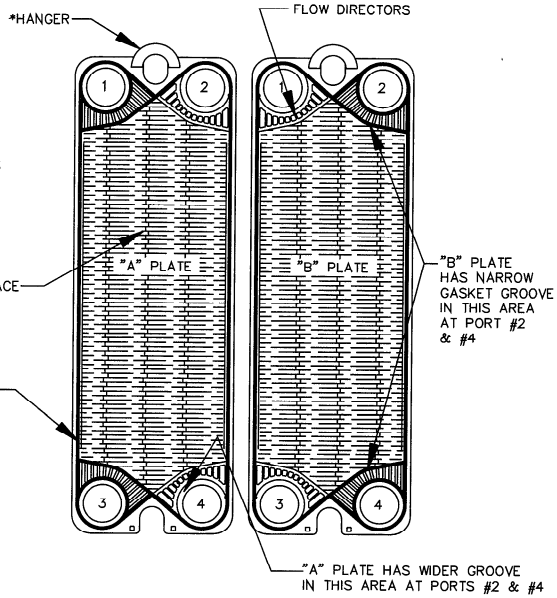
Each plate also contains flow directors at the top and bottom of the heat transfer surface in the port hole areas which evenly distribute the fluids. Some plates require a hanger which attaches the plate to the upper guide bar. For most models, the upper guide bar is the plate's sole support member in the frame, while the lower guide bar serves as an alignment member in all plates except the UX-05 and the UX-01 which are supported by the lower guide bar. See Figures 3, 4, 5, 6 & Tables 3 through 6 for specific models.

# PLATE DETAILS



**FIGURE 3**

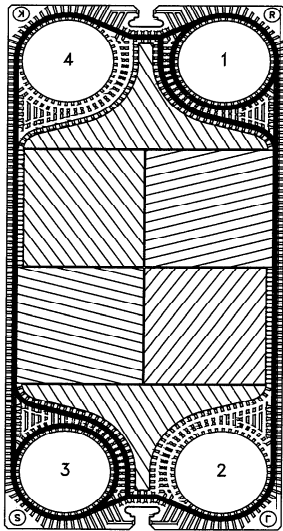
TYPICAL UX, SX, GC, T, OR V SERIES (HERRINGBONE) PLATE WITH GASKET AND HANGER. Note that the chevron angle for the herringbone plate can differ on various models.



**FIGURE 4**

TYPICAL S-SERIES (WASHBOARD) PLATE WITH GASKET AND HANGER

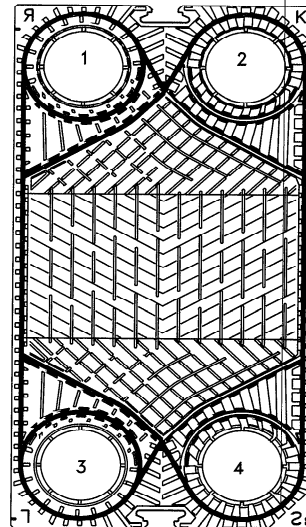
\*External hanger not required on some models (see Table 4)



**FIGURE 5**

TYPICAL UFX PLATE WITH GASKET

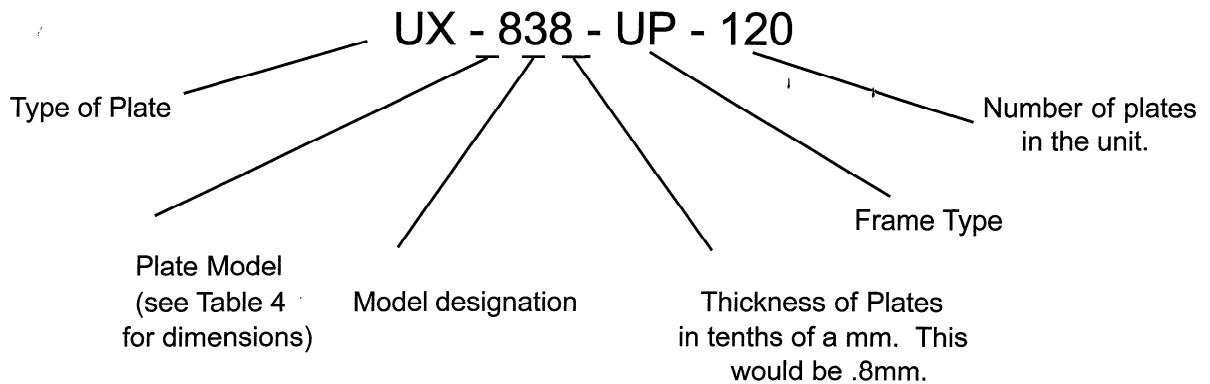
Note that the chevron angle for the herringbone plate can differ on various models.



**FIGURE 6**

TYPICAL TW PLATE WITH GASKET

## PART NUMBER



## FRAME PRESSURE RATINGS

Table 1

FRAME TYPE	NOMINAL ASME CODE PRESSURE RATINGS, PSIG	
	Design Pressure	Test Pressure
HJ/HP	100	150
UJ/UP	150	225
SJ/MJ/SP/MP	300	450
FP	350	525

## MIXED PLATE UNITS

Some SUPERCHANGER units combine plate models. Certain mixed plate units will feature UX-41 plates combined with UX-42 plates. Other units combine Model UX-81 plates with Model UX-82 plates, or Model UX-83 plates with Model UX-84 plates. Plate designations, arrangement and order are the same for these mixed plate units as for units with single plate models. Listed below are the unit model numbers for mixed plate SUPERCHANGER units currently available.

Table 2

Basic Model	Unit Model Designation	Plate Combination
05	UX-07	05 + 06
01	UX-09	01 + 02
10	UX-19	11 + 12
20, 04-V	UX-29, 04-V09	21 + 22, V1 + V2
06-T, 06-V	06-T9, 06-V09	06-T1 + 06-T2, V1 + V2
40, 08-V	UX-49, 08-V09	41 + 42, V1 + V2
11-T, 11-V	11-T9, 11-V09	11-T1 + 11-T2, V1 + V2
80, 18V	UX-89, 18-V09	81 + 82, V1 + V2
80, 18V	UX-88, 18-V08	83 + 84, V3 + V4

**Table 3 Plate Data UFX Series Plates**

Plate Data\Models	UFX-6	UFX-12	UFX-18	UFX-26	UFX-42	UFX-51
Heat Transfer Surface Area (ft <sup>2</sup> .)	0.753	1.292	1.937	2.906	4.736	5.920
Plate Width (in)	4-15/16	9-13/16	9-13/16	15-3/16	15-3/16	19-7/8
Plate Length (in)	27-3/4	27-3/4	37	37	53-1/4	53-1/4
Maximum connection Size (in)	1	2	2	4	4	6
Maximum Flow (gpm)	75	292	292	1171	1171	2264
Channel Volume Between Plates (gal)	0.0423	0.0872	0.124	0.227	0.351	0.444

**Table 3 Plate Data UFX Series Plates (cont.)**

Plate Data\Models	UFX-37	UFX-64	UFX-91	UFX-118	UFX-60	UFX-100
Heat Transfer Surface Area (ft <sup>2</sup> .)	3.983	6.889	9.795	12.701	6.028	10.872
Plate Width (in)	19-7/8	19-7/8	19-7/8	19-7/8	27-3/4	27-3/4
Plate Length (in)	42-3/16	61-1/16	80	98-7/8	47-1/8	69-15/16
Maximum connection Size (in)	6	6	6	6	8	8
Maximum Flow (gpm)	2769	2769	2769	2769	4755	4755
Channel Volume Between Plates (gal)	0.246	0.423	0.6	0.777	0.502	0.845

**Table 3 Plate Data UFX Series Plates (cont.)**

Plate Data\Models	UFX-140	UFX-180	UFX-85	UFX-145	UFX-205	UFX-265	UFX-325
Heat Transfer Surface Area (ft <sup>2</sup> .)	15.72	20.559	9.795	16.469	23.035	29.708	36.274
Plate Width (in)	27-3/4	27-3/4	37	37	37	37	37
Plate Length (in)	92-3/4	115-5/8	60-1/8	82-15/16	105-3/4	128-5/8	151-7/16
Maximum connection Size (in)	8	8	14	14	14	12	12
Maximum Flow (gpm)	4755	4755	10471	10471	10471	9183	9183
Channel Volume Between Plates (gal)	1.162	1.479	0.88	1.334	1.788	2.243	2.695

**Table 4 UX, SX, S Series Plates**

Plate Data\Models	UX-05	UX-01	UX-10	S3*	UX-20* 04-V	06-T* 06-V
Heat Transfer Surface Area (ft <sup>2</sup> .)	0.64	0.94	2.15	3.40	4.04	6.10
Plate Width (in)	8	8	11-13/16	16-3/4	16-1/2	24
Plate Length (in)	18-7/8	24-9/16	34-11/16	46-1/4	49-5/8	57-11/16
Maximum Connection Size (in)	2	2	3	4	4	8
Maximum Flow (gpm)	265	265	520	1060	1060	3825
Channel Volume Between Plates (gal)	0.06	0.08	0.13	0.40	0.34	0.67

**Table 4 UX, SX, S Series Plates (cont.)**

Plate Data\Models	07-S 07-V	S-8*	UX-40* 08-V	SX-40 10-V	11-T* 11-V	14-S 14-V	UX-80 18-V
Heat Transfer Surface Area (ft <sup>2</sup> .)	7.24	7.60	8.20	9.70	11.80	13.69	18.30
Plate Width (in)	26-5/16	24-1/4	24	26-5/16	24	26-5/16	40-13/16
Plate Length (in)	56-5/8	68-3/8	69-11/16	68-3/4	89-13/16	88-9/16	89-1/4
Maximum Connection Size (in)	8	8	8	8	8	8	14
Maximum Flow (gpm)	4754	3450	3825	4754	3825	4754	11200
Channel Volume Between Plates (gal)	0.52	0.90	0.87	0.63	1.21	0.81	2.40

\*External Hanger Required

**Table 5 Wide Gap Plates**

Plate Data\Model	TW-05	TW-10	TW-18	
Heat Transfer Surface Area (ft <sup>2</sup> .)	5.3	9.0	16.8	
Plate Width (in)	27.75	27.75	27.75	
Plate Length (in)	54	72	110	
Max Connection Size (in)	8	8	8	
Max Flow (gpm)	4755	4755	4755	
Channel Volume (U.S. gal)	Wide	2.36	3.23	5.08
	Medium	2.00	2.61	3.92
	Narrow	1.63	1.99	2.76

**Table 6 Minex & GC Series Plates**

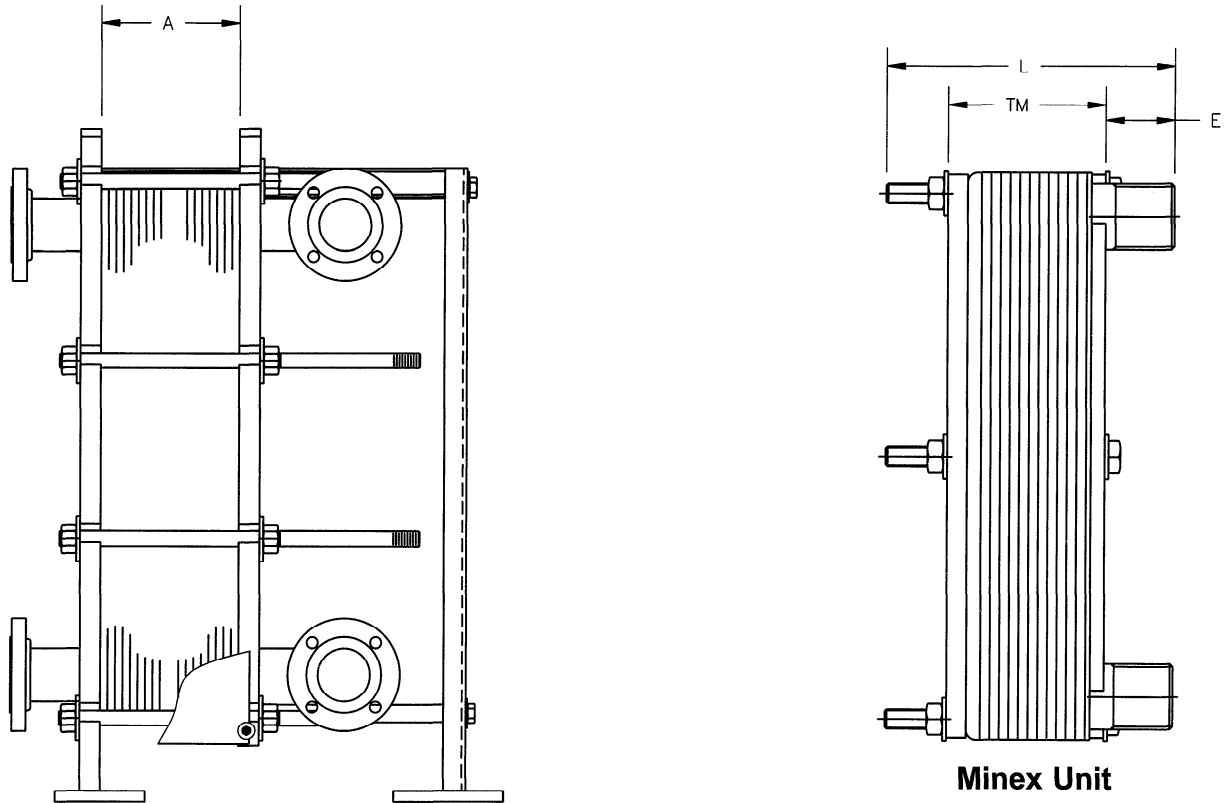
Plate Data\Model	M-4	M-10	GC-26	GC-28	GC-51	GC-60
Heat Transfer Surface Area (ft <sup>2</sup> .)	0.10	0.26	2.80	0.86	5.81	5.92
Plate Width (in)	2.9	4.5	15.16	4.92	19.88	27.75
Plate Length (in)	5.5	8.5	37	29.33	53.27	47.12
Max Connection Size	0.5	1	4	1	6	8
Max Flow (gpm)	10	56	1171	75	2324	4755
Channel Volume (U.S. gal)	0.0056	0.013	0.2642	0.040	0.55	0.783

**Table 7 Frame Dimensions, Inches**

Model	Height	Width	Connection Size (in)	Model	Height	Width	Connection Size (in)
UFX-6	37	8-1/4	1	S-3	58	22	2, 3, 4
UFX-12	39	14	2	UX-20 (04-V)	62	24	2, 3, 4
UFX-18	48	14	2	06-T (06-V)	74	32	4, 6, 8
UFX-26	54	22	2, 4	07-S (07-V)	71	36	4, 6, 8
UFX-42	71	22	2, 4	S-8	85	30	4, 6, 8
UFX-51	72	27	4, 6	UX-40 (08-V)	85	32	4, 6, 8
UFX-37	60	27	4, 6	SX-40 (10-V)	83	36	4, 6, 8
UFX-64	79	27	4, 6	11-T (11-V)	106	32	4, 6, 8
UFX-91	98	27	4, 6	14-S (14-V)	103	36	4, 6, 8
UFX-118	117	27	4, 6	UX-80 (18-V)	105	54	10, 12, 14
UFX-60	69	38	4, 6, 8	M-4	7-1/2	3	1/2
UFX-100	92	38	4, 6, 8	M-10	11-1/2	4	1
UFX-140	115	38	4, 6, 8	GC-26	54	22	2,3,4
UFX-180	138	38	4, 6, 8	GC-28	31	7	1
UFX-85	81	50	10, 12, 14	GC-51	72	27	4,6
UFX-145	104	50	10, 12, 14	GC-60	69	38	4,6,8
UFX-205	127	50	10, 12, 14	TW-05	71	35	4,6,8
UFX-265	149	50	10, 12, 14	TW-10	88	35	4,6,8
UFX-325	172	50	10, 12, 14	TW-18	126	35	4,6,8
UX-05	24	12	1, 2				
UX-01	31	12	1, 2				
UX-10	45	17	2, 3				

## PLATE PACK WIDTHS “A” DIMENSION FOR STANDARD THICKNESS MATERIALS

Calculating the “A” dimension (Plate Pack Width in Inches) for various SUPERCHANGER Models can be accomplished using the formulas indicated in Table 8 (page 8). N= Number of Plates.



**Figure 7**

PLATE DESIGNATION, p	PLATE THICKNESS, t
5	0.019685
6	0.023622
7	0.027559
8	0.031396
0	0.039370

N = Number of Plates  
p = Plate Thickness Designation  
t = Plate Thickness in Inches

Please contact the Texas Division for the “A” Dimension when other Plate thicknesses are involved.

**TABLE 8 - Plate Pack Tightening Dimensions**

<b>PLATE TYPE</b>	<b>A MAX* (Inches)</b>	<b>A MIN* (Inches)</b>
UX-05p, -06p, -07p	(t+.102362)N	(t+.094488)N
UX-01p, -02p, -09p	(t+.102362)N	(t+.094488)N
UX-11p, -12p, -19p	(t+.090551)N	(t+.082677)N
UX-21p, -22p, -29p	(t+.108268)N	(t+.102362)N
04-V1p, -V2p, -V9p	(t+.108268)N	(t+.102362)N
06-T1p, -T2p, -T9p	(t+.141732)N	(t+.133858)N
06-V1p, -V2p, -V9p	(t+.141732)N	(t+.133858)N
UX-41p, -42p, -49p	(t+.141732)N	(t+.133858)N
08-V1p, -V2p, -V9p	(t+.141732)N	(t+.133858)N
11-T1p, -T2p, -T9p	(t+.141732)N	(t+.133858)N
11-V1p, -V2p, -V9p	(t+.141732)N	(t+.133858)N
07-S1p, SX-41p, 14-S1p	(t+.102362)N	(t+.094488)N
07-V1p, 10-V1p, 14-V1p	(t+.102362)N	(t+.094488)N
UX-81p, -82p, -89p	(t+.181102)N	(t+.173228)N
18V1p, -V2p, -V9p	(t+.181102)N	(t+.173228)N
UX-83p, -84p, -88p	(t+.181102)N	(t+.173228)N
18-V3p, -V4p, -V8p	(t+.181102)N	(t+.173228)N
S-3	(0.196850N) + 0.07874	(0.192913N) + 0.07874
S-8	(0.192913N) + 0.07874	(0.188976N) + 0.07874
UFX-6	(t+0.10191)N	(t+0.09491)N
UFX-12, -18	(t+0.11321)N	(t+0.11021)N
UFX-26, -42	(t+0.13441)N	(t+0.12541)N
UFX-37, -64, -91, -118	(t+0.11821)N	(t+0.11021)N
UFX-51	(t+0.13441)N	(t+0.12541)N
UFX-60, -100, -140, -180	(t+0.13441)N	(t+0.12541)N
UFX-85, -145, -205, -265, -325	(t+0.13441)N	(t+0.12541)N
TW-05, -10, -18	(t+0.3202)N	(t+0.3098)N
GC-26	(t+0.1633)N	(t+0.1523)N
GC-51	(t+0.1601)N	(t+0.1548)N
GC-60	(t+0.1831)N	(t+0.1713)N

\* Applicable to units with elastomeric gaskets, round off to the nearest 1/32". Units with teflon encapsulated gaskets should be tightened to the "A Max." formula.

**CAUTION: On units operating in excess of 200 psig, the tightening dimension is to equal or approaches the minimum dimension.**

The last digit of the above model numbers "p", indicates the plate thickness in tenths of a millimeter. The only exception is the zero (0) designation which indicates a 1.0 millimeter plate thickness.

**HOW TO USE TABLE 8:**

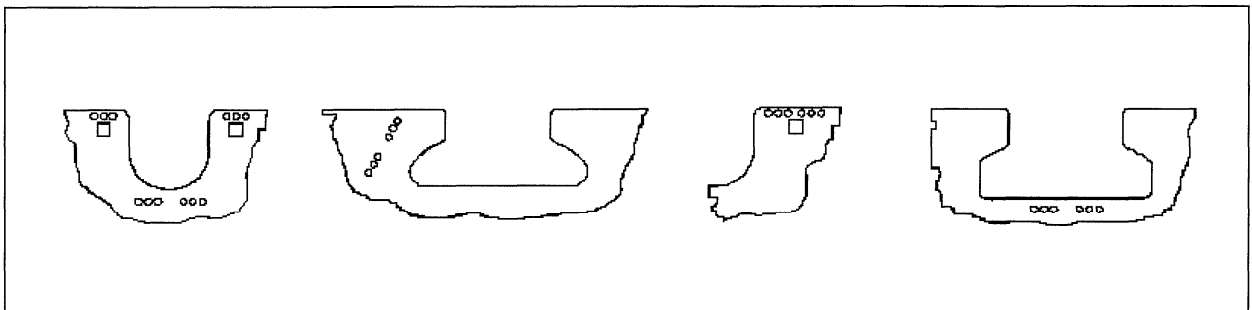
EXAMPLE: Given a model UX-126-MP-32, go to the chart showing Plate Designation and Plate Thickness. The Plate Designation for a model UX-126 is 6 and the corresponding Plate Thickness is 0.023622 inches. Now find the row showing UX-12p, which corresponds to UX-126. The "A Max" dimension is calculated by: (t+.090551)N = (0.023622+0.090551)32 = 3.65 inches. The "A Min" dimension is calculated in a similar manner. Round off calculated number to nearest 1/32".

**TABLE 9**  
**PLATE MATERIAL AND DATE OF MANUFACTURE DATA**

All plates are stamped with identification numbers. The numbers are located on both ends of the plates as indicated in the sketches below. The heat number, material and month and year of manufacture can be determined from these numbers.

PLATE IDENTIFICATION NUMBER			
HEAT NO. CODE	MATERIAL	YEAR	MONTH
PROCURE FROM ENGINEERING			
	1 304 SS	2 1992	1 JAN/FEB
	2 316 SS	3 1993	2 MAR/APR
	3 TITANIUM	4 1994	3 MAY/JUNE
	4 316L SS	5 1995	4 JULY/AUG
	5 HAST-C-276	6 1996	5 SEPT/OCT
	6 INCOLLOY 825	7 1997	6 NOV/DEC
	7 MONEL 400	8 1998	
	8 316 HIGH MOLY	9 1999	
	9 304L SS	0 2000	
	0 OTHER	1 2001	
	NICKEL		
	317 SS		
	317L SS		

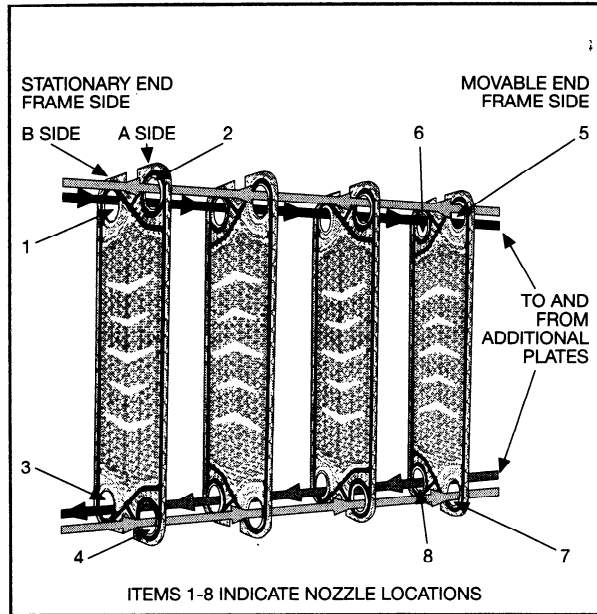
**GENERAL LOCATION DETAIL**



**Figure 8**

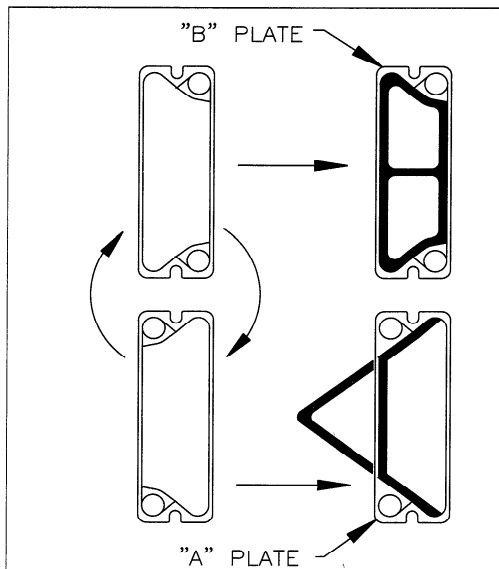
# PLATE DESIGNATIONS:

UX, SX, S, GC, TW, V Series:



**Figure 9**  
**SUPERCHANGER FLOW DIAGRAM**  
**AND NOZZLE NUMBER SYSTEM**

SUPERCHANGER units are designed so that a fluid which enters the “A” plate circuit (nozzles #2, 4, 5, or 7) always flows in the “A” circuit only. Fluid which enters the “B” plate circuit (nozzles #1, 3, 6, or 8) always flows in the “B” circuit only. Facing the stationary frame, the right side is always the “A” side, while the left side is always the “B” side.



**Figure 10**

The “A” and “B” term refers to the gasket orientation when looking at the gasketed side of the plate an “A” plate becomes a “B” plate when reversed (turned upside down). If the flow comes in and out on the left side it is a “B” orientation.

NOTE: Every other plate has to be rotated 180° **A-B-A-B** in order to prevent mixing. The first plate in the unit is called a “D” plate and has a special gasket arrangement. This arrangement keeps the flow from contacting the stationary frame. The last is called the “E” plate and is gasketed normally.

# DRAWINGS

SUPERCHANGER units are custom designed for each application. A drawing is supplied with each unit depicting all required dimensional data, equipment specifications, unit performance, nozzle locations and sequence of plates in the heat exchanger. Most information contained on the drawing is self-explanatory. However, sections illustrating the internal functions of a plate and frame heat exchanger are sometimes difficult to interpret. The following is an aid for understanding the equipment.

## ELEMENT COMPOSITION DIAGRAM

Figure 11 shows an "S" frame (stationary member), "E" frame (moveable member), and plates of the plate heat exchanger depicted in an element composition diagram. In an element composition diagram, "B" plates are located at the upper part of the drawing and "A" plates are shown on the lower side.

A plate is indicated by the line centrally located within a rectangular compartment between the "S" and "E" frames.

The designation of plate holes is written in the hole designation box formed by extending the vertical plate lines above the center line for "B" plates and below the center line for "A" plates. The plate sequence number is written in a box above and below the plate hole number, respectively, for "B" and "A" plates.

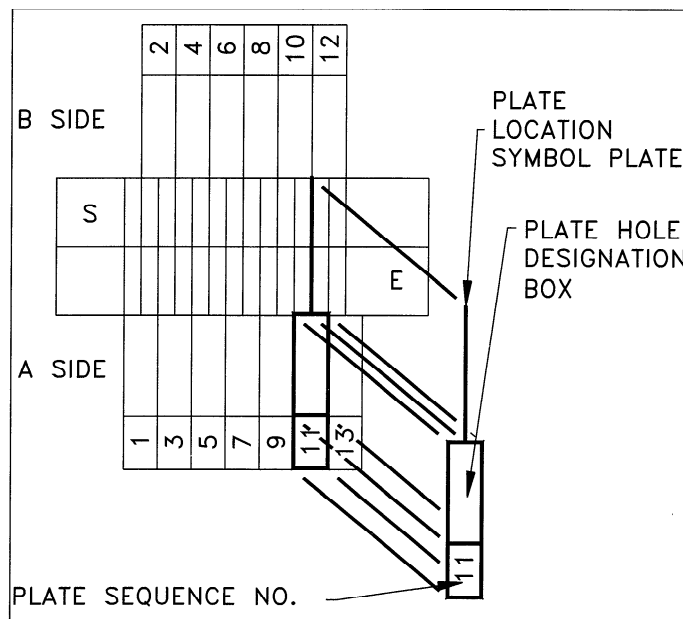
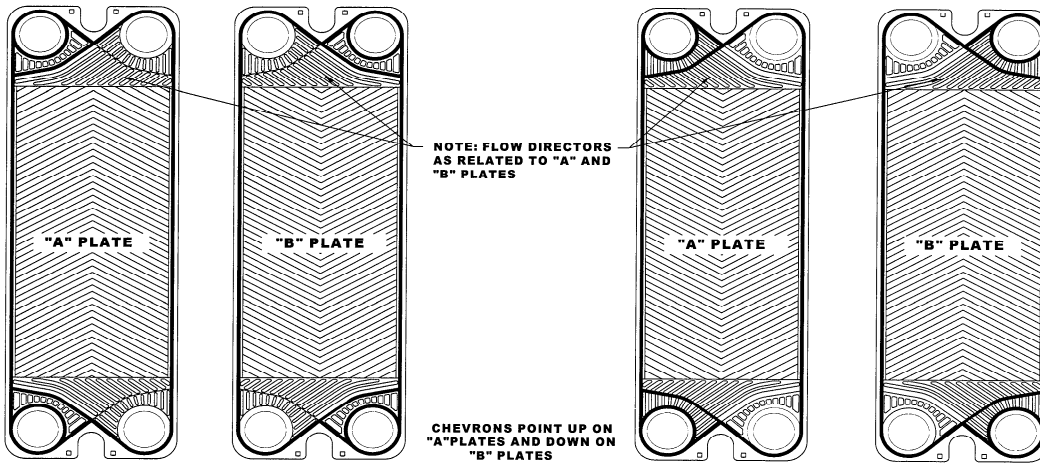
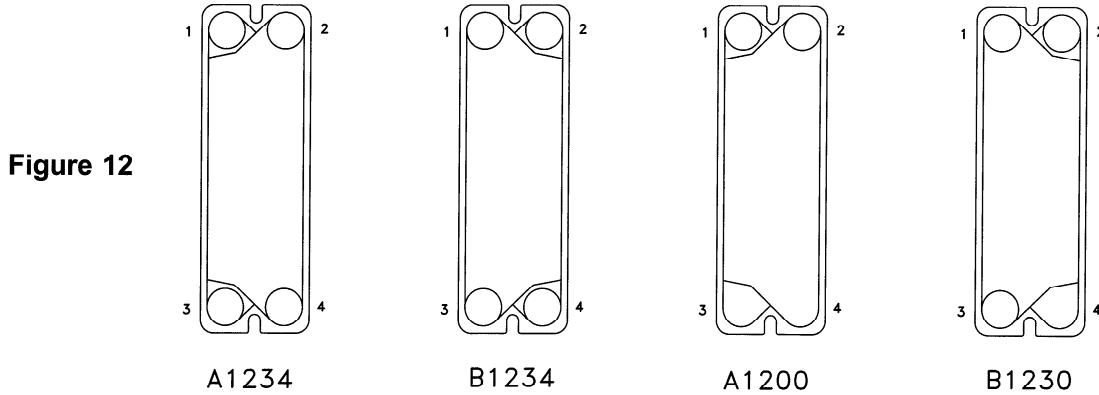


Figure 11

# PLATE HOLE DESIGNATION: UX, SX, S, GC, TW, V Series

As shown in Figure 12, the pierced holes at the corners of the plate are designated as: 1 for upper left, 2 for upper right, 3 for lower left, and 4 for lower right when facing the gasketed side of the plate. Plates 1 and 2 in Figure 12 are represented as A1234 and B1234 respectively. Plates with all four holes pierced can also be designated with a blank space or a \*. Unpierced ports will be represented as a 0. For example, Plate 3 is represented by a A1200 since there are no holes at position 3 (lower right and holes are in all the other locations. Table 10, shows A & B equivalents when an "A" plate is rotated to become a "B" plate.



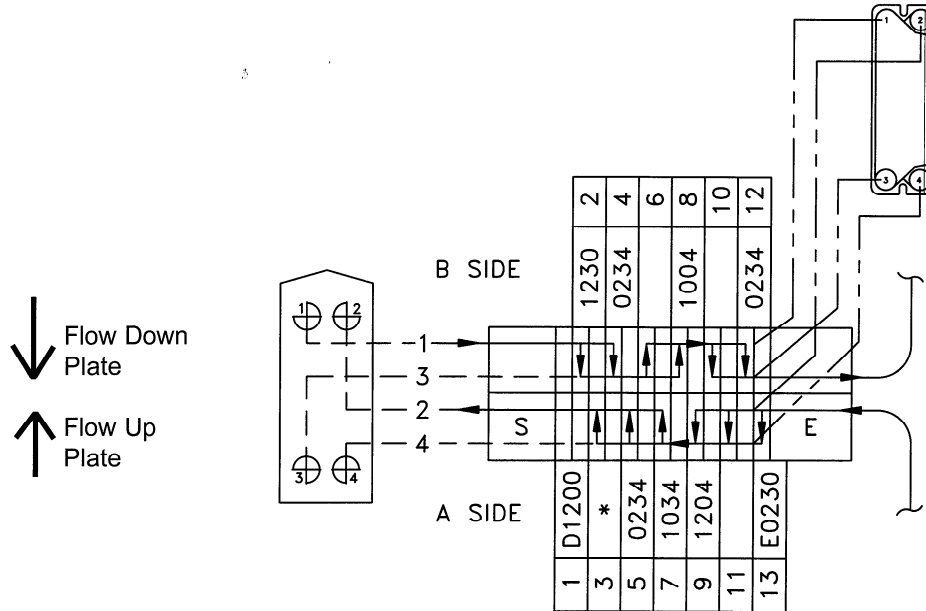
**Figure 13a - Correct**

**Figure 13b - Incorrect**

Make sure the gaskets are installed correctly in relation to the flow directors. (See Figures 13a and 13b).

**TABLE 10**  
**"A" AND "B" EQUIVALENTS**

"A" Plate	"B" Plate	"A" Plate	"B" Plate
1234	1234	1004	1004
1230	0234	1030	0204
1204	1034	0204	1030
1034	1204	1000	0004
0234	1230	0200	0030
1200	0034	0030	0200
0034	1200	0004	1000
0230	0230	0000	0000



**Figure 14a**  
**ELEMENT COMPOSITION DIAGRAM**

*\*No number indicates that fluid passes through all four holes in the plate.*

## PLATE PASS ARRANGEMENT:

Positions 1 and 2, as shown above in Figure 14a, are upper connections, left and right respectively, and positions 3 and 4 are lower connections, left and right respectively. Each vertical line in between the “S” and “E” members represents a heat transfer plate while the arrows show the directions of flow in the channels between two plates and in the port holes.

The position of a plate hole is indicated by the intersection between a vertical line representing the plate and a horizontal line indicating the flow direction and passage. Holes for passage of fluid flowing on the surface of a “B” plate are always located on the left side (Holes 1 and 3), and holes for passage of liquid flowing on the surface of an “A” plate are always found on the right side (Holes 2 and 4).

In the element composition diagram (Figure 14a), plate numbers are shown in boxes as:

1	D1200
---	-------

 (“A” side), 

1230	2
------	---

 (“B” side”).

“D” in D1200 represents the plate adjacent to the “S” frame. “D” also denotes that no fluid runs on the heating surface.

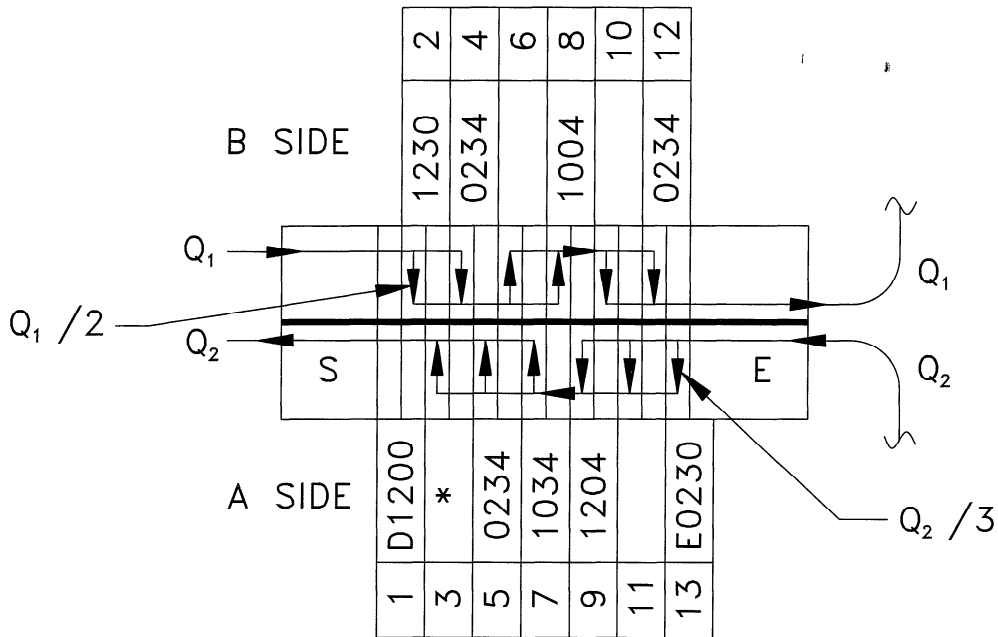
A box with no port hole numbers, 

11	
----	--

, in Figure 14a means 

11	1234
----	------

. This is done for simplicity as most plates in a unit have four (4) holes.



**Figure 14b**  
**FLOW ARRANGEMENT**

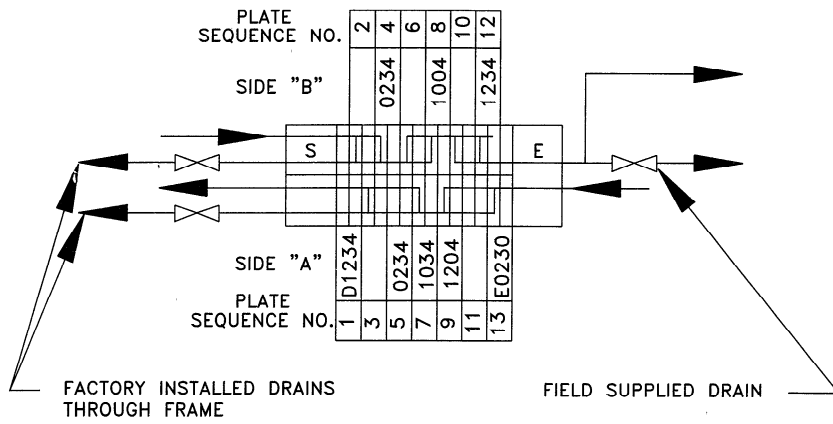
\*No Number indicates that fluid passes through all four holes in the plate.

## DRAINS

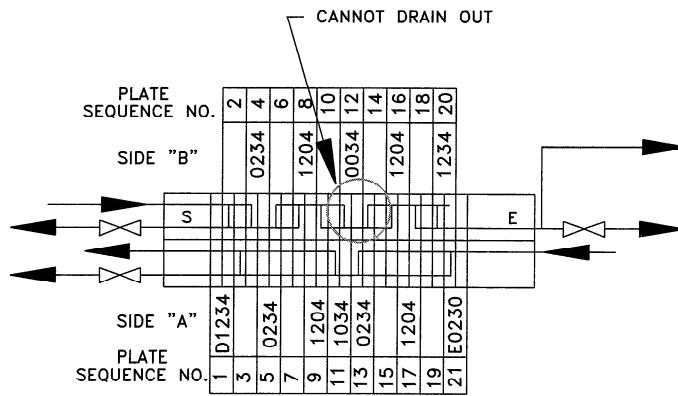
There are three methods used for draining SUPERCHANGER units:

1. One pass/one pass (also two pass/two pass with all lower nozzles, but not shown) units can be drained by opening the piping to the lower nozzles or by opening drain valves that can be provided in the field in the connecting piping. See Figure 15.
2. Multi-pass unit may require factory installed drains, i.e., an additional nozzle in the end frame. These must be factory installed. See Figure 15.
3. If the number of passes is greater than four as in Figure 16 the above options require the addition of small holes in plate corner sections as shown in Figure 17. The amount of bypass through these holes is negligible and there is no possibility of fluid intermix. These drain holes in the element composition in diagram are noted by ●, as the small hole is always placed in the corner without a passage hole. For example, 1204 is changed to 12●4 if a drain hole is present. The size and position of the drain hole is separately specified.

**NOTE:** On multipass units which are sized for a close temperature approach these drain holes are not provided due to the small amount of bypassing that occurs. Check the drawing to determine whether drains are present.

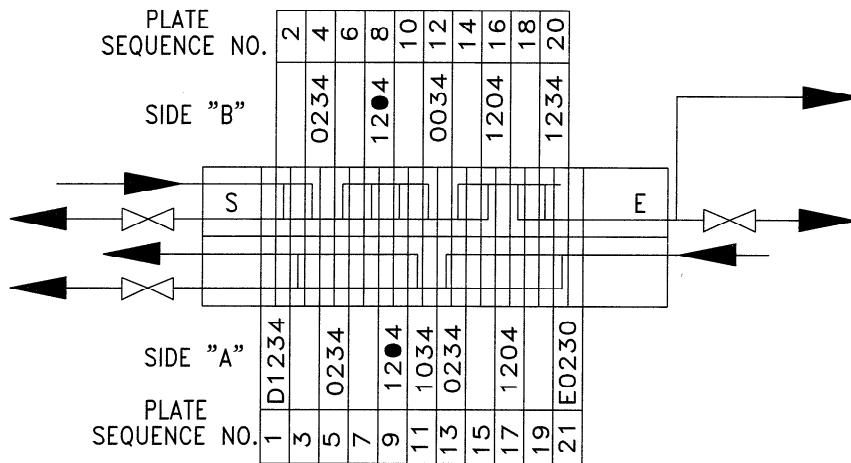


**FIGURE 15**



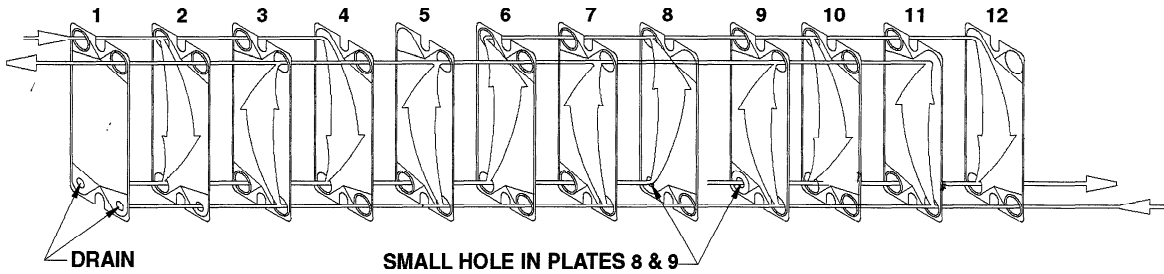
**FIGURE 16**

Figure 16 shows a 5-pass unit with 2 passes that are not drainable.



**FIGURE 17a**

Figure 17a is the same as Figure 16 except showing pass 3 and 4 as drainable. (i.e., plates 8 and 9 have small drain holes).

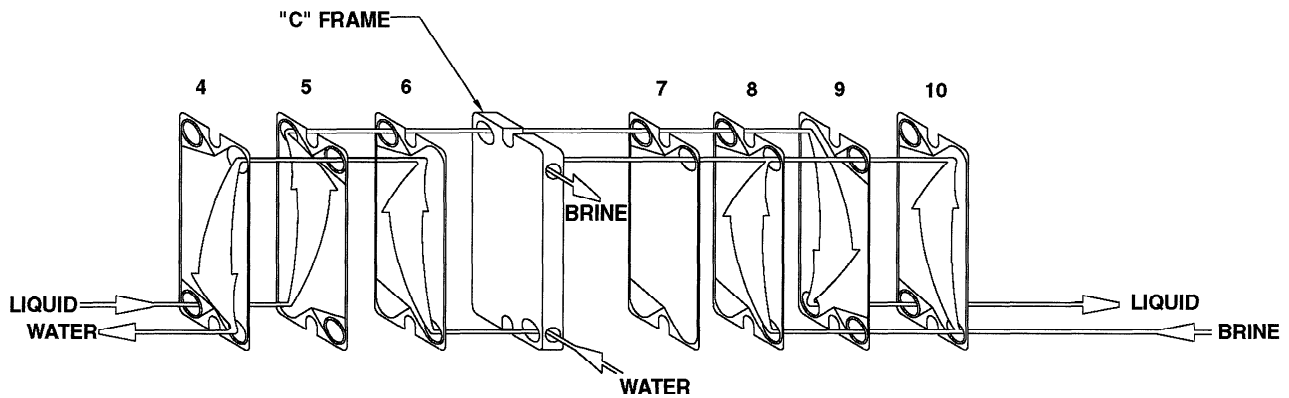


**FIGURE 17b**

Showing first 12 of the 21 plates in Figure 17a with drains in Plates 8 and 9.

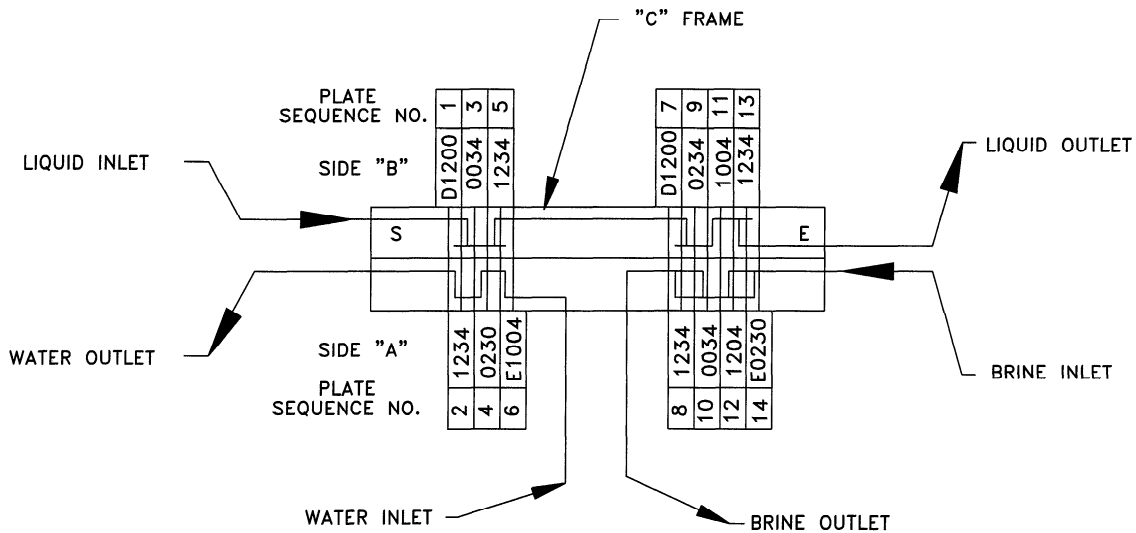
## CONNECTING "C" FRAMES:

SUPERCHANGER units can be partitioned into multiple sections by employing the required number of connecting "C" frames when more than one heat exchange operations is required. Connecting frames allow several liquids to be processed at the same time or allow the same liquid to run through several stages of heat transfer. The flow arrangement with use of a connecting frame is illustrated in Figure 18a isometrically and in Figure 18b in an element composition diagram.



**Figure 18a**

Connecting "C" Frame - Flow Diagram



**Figure 18b**

Connecting "C" Frame - Element Composition Diagram

# ULTRAFLEX (UFX) DESIGN

Unlike all other SUPERCHANGER models, the UFX series of plates is based on a diagonal flow pattern. Thus, you will note that we have varied the nozzle designation pattern on the UFX design (see Figure below). On a typical one-by-one pass unit, nozzle numbers 1 + 3 will still be the hot inlet and hot outlet, but they are now located upper right and lower left. Nozzle numbers 2 + 4 are the cold inlet and cold outlet located lower right and upper left respectively.

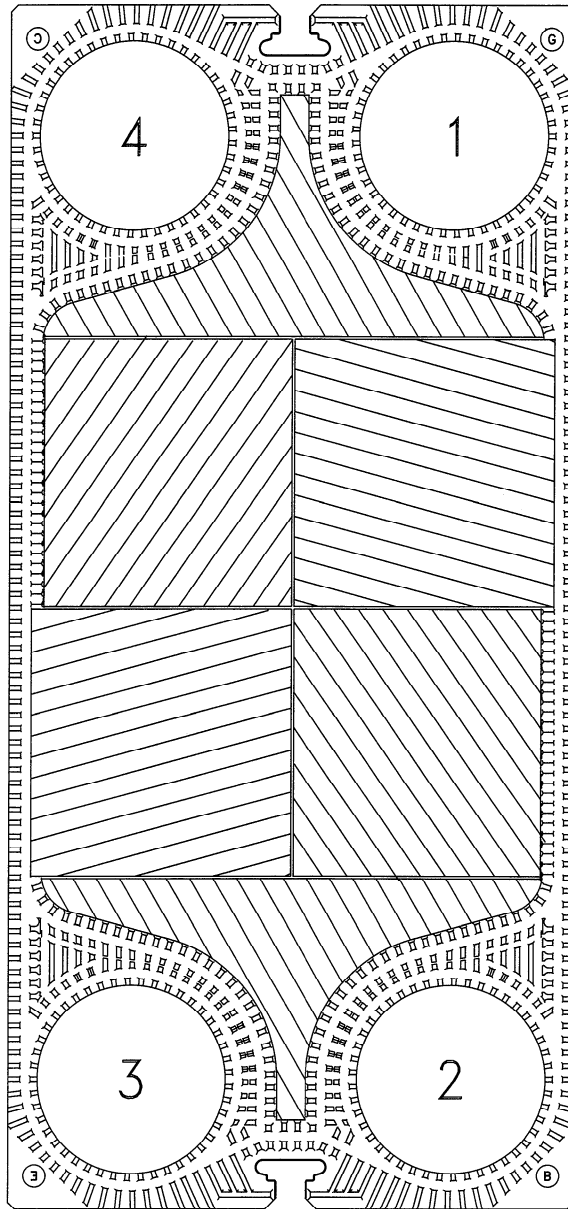
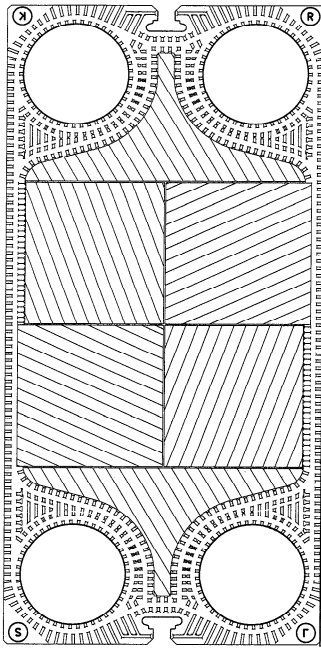


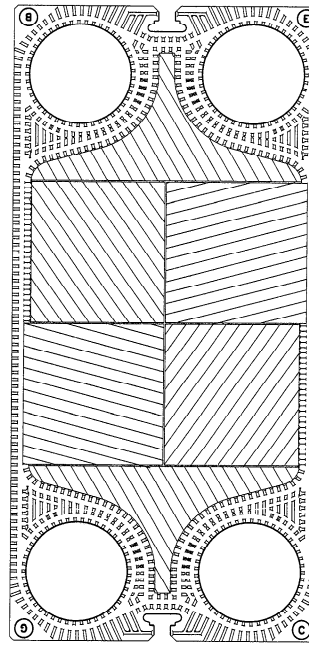
FIGURE 19

## PLATE DESIGNATIONS - ULTRAFLEX and WIDEGAP

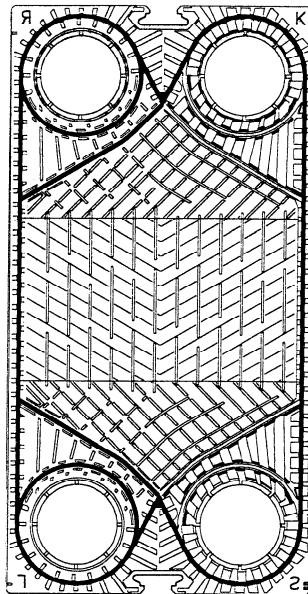
ULTRAFLEX (UFX) and WIDE GAP (TW) plates differ from conventional plates in another aspect. Because the gasket groove lies in the plate's neutral plane, additional configurations are possible with a given plate. This feature allows the heat exchanger to be more precisely designed for each application.



**Figure 20a**  
**UFX TYPE L PLATE**



**Figure 20b**  
**UFX TYPE H PLATE**



**Figure 20c**  
**TYPE TW PLATE**

# DRAWINGS

The bottom left hand corner of each TW and UFX unit drawing has a plate specification chart and plate arrangement/assembly listing to assist in determining the proper sequence and orientation of the plates in the unit. You will note that the gaskets used between the first and last plate of the plate pack and the respective frames are half thickness.

Due to the number of combinations achievable with UFX and TW technology, we have simplified the assembly process by assigning a letter to each corner of the plate. The plate is installed correctly when the letter is readable from the upper right corner when facing the front of the unit.

The following examples will help you understand the plate designations:

## ULTRAFLEX PLATE ASSEMBLY

<u>PLATE NO.</u>	<u>TYPE</u>	<u>CODE</u>	<u>GASKETS</u>
1	H	B	Half Gasket Front
Even 2-140	H	E	Full Gasket Front, Upper RH & Lower LH Port
Odd	H	B	Full Gasket Front, Upper LH & Lower RH Port
141	H	B	Full Gasket Front, Upper LH & Lower RH Port Half Gasket Back

## WIDE GAP PLATE ASSEMBLY

In the Wide Gap (TW) series of plates, three different channel geometries can be created with each model: wide, medium, or narrow. All units will be wide-narrow, narrow-wide, or medium-medium configuration. The code letter in the top right hand corner of the plates is used to create the various channel geometries as shown below.

<u>GAP</u>	<u>FLOW ON SIDE</u>	<u>CODE</u>
Wide	A	R + L
Wide	B	S + K
Medium	A	K + L
Medium	B	L + K
Narrow	A	K + S
Narrow	B	L + R

# PORT PUNCH:

There is a set of numbers in the plate specification box under the "ports" title. The numbers are a designation for which port holes have been punched out. A zero only designates that no holes have been punched. A zero intermixed in other numbers means that particular location has not been punched. UFX port designations differ from other models due to the diagonal flow design. For example:

A 1204 designated plate would like this:

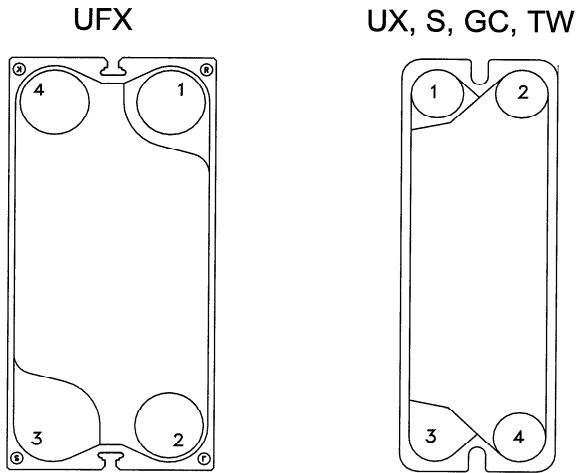


Figure 21a

A 0230 designation would look like this:

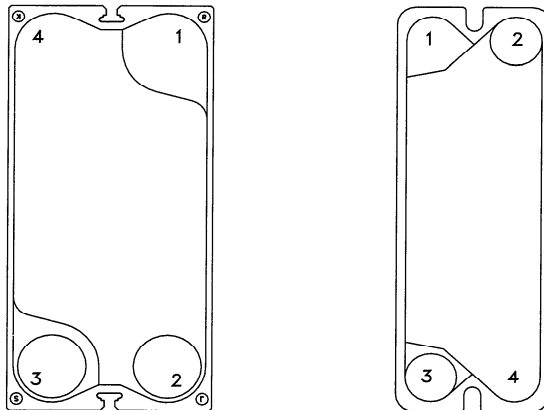


Figure 21b

The ports must be punched with the correct letter in the upper right corner for its location in the plate sequence. For example, a plate in the sequence designated code R with a 1004 punch would look like this:

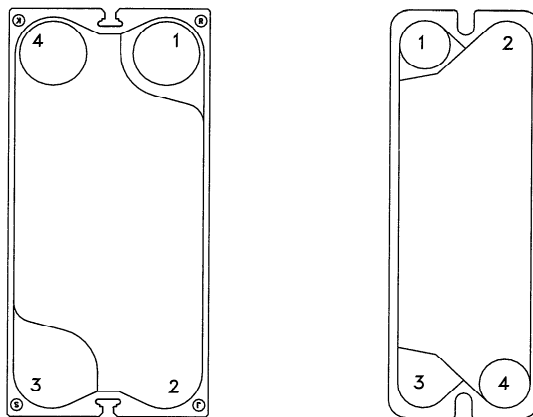


Figure 21c

## FOUR PLATE SEQUENCE - ULTRAFLEX

In some instances, the arrangement in a UFX model will follow a repeating four plate sequence. An example is shown below:

### PLATE ASSEMBLY

Plate 1 Type H Code B Half gasket front

Even plates 2 through 206 Type L Code R, Full gasket front, Upper RH & Lower LH port

Odd plates Type H Code B, Full gasket front, Upper LH & Lower RH port

Even plates 208 through 268 Type L Code S.R, Full gasket front, Upper RH & Lower LH port

Odd Type H Code C.B, Full gasket front, Upper LH & Lower RH port

Plate 269 Type H Code C, Full gasket front, upper LH, lower RH port Half gasket back

In the example above, Even plate Code S.R means Plate 208 will be Code S and Plate 210 will be Code R; Odd Plate 209 will be Code C and Plate 211 will be Code B; Plate 212 is Code S and the four plate sequence continues as shown below:

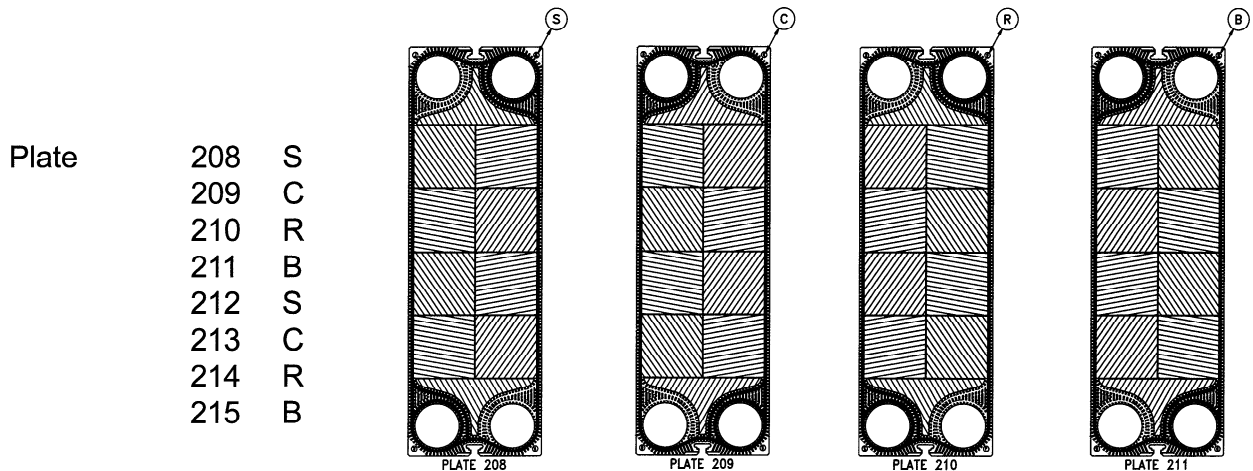


Figure 22

## MULTI-PASS UNITS

Here is an example of plate arrangement and specifications for a multi-pass unit:

### PLATE ASSEMBLY

Plate 1 Type H Code B Half gasket front, Ports 2, 3

Even Plates 2 through 24 Type L Code R, Full gasket front, Upper RH & Lower LH ports

Odd Plates Type H Code B, Full gasket front, Upper LH & Lower RH ports

Plate 25 turning plate, Type H Code B, Full gasket front, Upper LH & Lower RH ports, ports 1, 4

Even Plates 26 through 48 Type L Code R, Full gasket front, Upper RH & Lower LH ports

Odd Plates Type H Code B, Full gasket front, Upper LH & Lower RH ports

Plate 49 Type H Code B, Full gasket front, Upper LH, Lower RH port Half gasket back, Ports 2, 3

# GASKETS

**TABLE 11 - TEMPERATURE RATINGS**

Gasket Material	Max. Temp.	Gasket Material	Max. Temp.
EPDM (Industrial Grade)	366°F	NBR (Full FDA Approved)	270°F
EPDM (Full FDA Approved)	300°F	Neoprene (CR)	255°F
Hypalon (CSM)	158°F	Fluoroelastomer A, G, GF	350°F
Teflon Encapsulated NBR*	270°F	Fluoroelastomer B	220°F
NBR (Industrial Grade)	270°F	Hydrogenated NBR	302°F

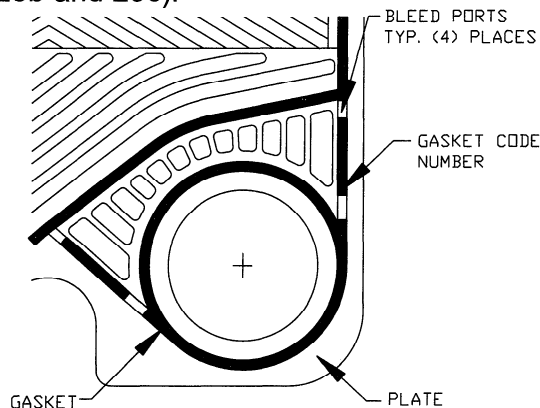
\*This gasket requires the use of .8mm (.032") thick plate and a special double side tape instead of Pliobond. **DO NOT OVER TIGHTEN!**

The above temperatures are the maximum allowable regardless of applications. In some cases, the upper limit may be lower depending on the fluids being handled and on the unit design pressure.

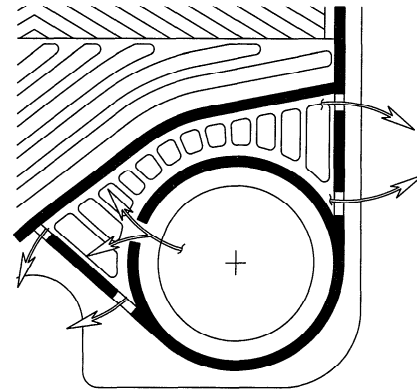
## GASKETS GLUED

Each plate has a molded one piece boundary gasket which is glued into the continuous gasket groove in each plate. The liquid flowing on the surface of each plate flows on the inside of each boundary gasket.

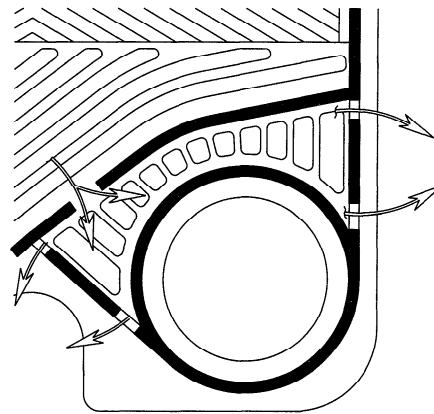
Every port hole gasket contains four bleed passages. (See Figure 23a). If one of the liquids should leak beyond a boundary gasket, it will flow to the outside of the unit, thus preventing any possible intermix. (See Figures 23b and 23c).



**Figure 23a**



**Figure 23b**



**Figure 23c**

## **GASKETS GLUELESS**

Functionally, Tranter's patented SUPERLOCK glueless gaskets perform in the same manner as glued gaskets (see Figures 23a, 23b, and 23c). SUPERLOCK's unique lock-in design allows simple installation and removal without glue. The gasket has tabs which press easily into the holes in the plate. Please note that the differences between glueless gasket plate assemblies and glued gasket plate assemblies do not allow for the use of a glued gasket on a SUPERLOCK style plate. The use of a glueless gasket on a plate requiring a glued gasket is also incorrect. (NOTE: the D, E, and any special turning plates will be standard spot-glued gasketed.) The SUPERLOCK design is available on the following models: UX-05, UX-01, UX-20, UX-40, and 06-T.

## **GASKET STORAGE PROCEDURES**

When SUPERCHANGER heat exchanger plate gaskets are maintained as spare parts, it is important that certain storage procedures be followed to assure that the elastomeric compounds making-up the gaskets do not deteriorate and the useful life of the gaskets is preserved.

1. Store in an area where the temperature does not exceed 70°F. The ideal storage temperature is 60°F. NEVER STORE IN AN AREA WHERE THE TEMPERATURE MAY FALL TO OR BELOW 32°F.
2. Maintain a maximum of 70% relative humidity.
3. Store in a darkened room. Ultraviolet light must be avoided.
4. Store gaskets so they are free from tension. Do not store in a stretched or severely bent condition.
5. All potential sources of Ozone, such as operating electric motors, or welding equipment, must be removed from the storage area.
6. Organic solvents, acids, etc. must not be kept in the storage area.
7. Do not store near heating system radiators.
8. Cover or keep the gaskets in bags or boxes to minimize exposure to air circulation.
9. Keep gaskets free from dust and particulates.

## **MIXED GASKET MATERIALS**

Most SUPERCHANGER units are equipped with gaskets made of one material. However, there are two conditions that dictate the use of different material on a plate.

The first gasket/fluid compatibility. In this case, one material is not suitable for both fluids in the heat exchanger. An example is heating quench oil with 285°F steam. Quench oil dictates the use of nitrile rubber gaskets, while steam temperature requires EPDM gaskets.

## MIXED GASKET MATERIALS (cont.)

The second reason for using two gasket materials on a single plate is cost. This is encountered when an expensive material (usually viton) is required on only one side of the SUPERCHANGER unit. A significant savings can be realized by using a less expensive gasket material on the other side.

As an example: cooling 180°F sulfuric acid with tower water requires viton on the acid side, but nitrile is sufficient on the water side.

Each plate has contact with both fluids in a SUPERCHANGER unit. One fluid travels across the plate while the other fluid passes through the gasketed port holes. In a mixed gasket unit, each plate will have two materials. The fluid traveling across the "A" plate requires gasket material 1. The fluid on the "B" plate requires gasket material 2.

In the case of a UX, SX, TW, GC, or S series model, the "A" plate will have material 1 on the perimeter while port holes 1 and 3 are material 2. The "B" plate will have material 2 on the perimeter with port holes 2 and 4 of material 1. UFX models with mixed gaskets would be similar. However, flow is diagonal so diagonally opposed ports would have the same gasket material.

All SUPERCHANGER gaskets are purchased as one piece-molded items. To physically accomplish mixing gaskets on a plate, the port holes are cut from both gaskets. Subsequently, the port holes of material 1 are matched with the perimeter of material 2 and vice versa. See Figure 24.

The following illustrates the above in a typical UX Series Plate.

▬▬▬▬▬▬ = Gasket Material 1  
▬▬▬▬▬▬ = Gasket Material 2

Fluid on "A" Plate uses port holes 2 and 4.

Fluid on "B" Plate uses port holes 1 and 3.

NOTE: Chevron orientation as related to "A" & "B" Plates.

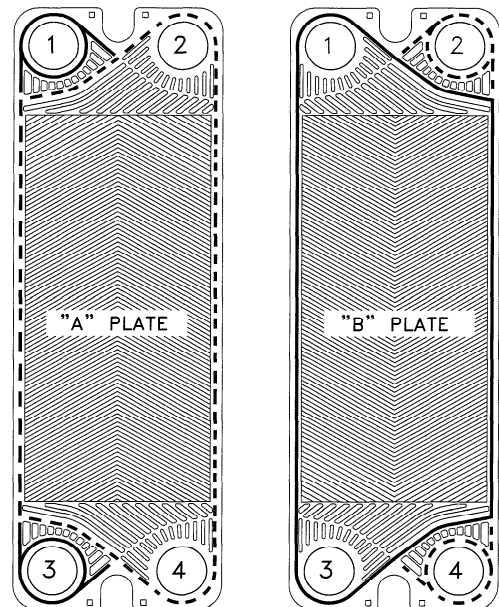


Figure 24

# INSTALLATION

## UNPACKING

SUPERCHANGER units (with optional shroud) are bolted to and shipped assembled on a skid. Other optional items, if supplied, are packed separately. All items should be checked against packing lists. SHOULD ANY PARTS BE MISSING OR DAMAGED, NOTIFY TRANTER, inc., Texas Division, P O Box 2289, Wichita Falls, Texas 76307, Phone: (940) 723-7125, IMMEDIATELY.

## RECOMMENDED PROCEDURES

All frame models except UX-05 are provided with special lifting eyeholes for transportation and installation by crane. Rigidly set all models on the floor by means of foundation bolts. The following installation tips are also recommended:

1. Level the unit.
2. Locate the unit in an area that is not congested with piping and other equipment. For units with nozzles on the movable frame, refer to Figures 25a & 25b, on page 27.
3. Provide three feet of working area around the unit.
4. The piping system must allow for thermal expansion. This can be accomplished inherently within the piping layout or by flexible connections.
5. Debris can cause damage to the gaskets. The gasket areas must be free from sand, gravel, pieces of iron, etc. before the unit is closed.
6. Lubricate the tie bolts.
7. Tighten all tie rod nuts. Tighten the unit to plate pack dimension per assembly drawings prior to making any assembly connections.
8. Uniformly tighten the plate pack. (See tightening instructions following.)
9. Flush connecting piping of all debris prior to "hook-up" with the heat exchanger.
10. Correctly center gaskets inserted between pipe flanges.
11. Do not apply valve and piping loads to the nozzles. Use pipe supports.
12. Install shutoff valves at all nozzles locations.
13. Place vent valves for draining at the highest possible point
14. Provide pumps sending liquid into the SUPERCHANGER with throttling valves.
15. Install a safety relief valve if the maximum pressure output of the pump is greater than that of the heat exchanger.
16. When a pressure control valve is installed, place it at the inlet of the heat exchanger, even if a pressure control switch is provided.

**CAUTION:** Do not expose plate and frame heat exchangers to continuous vibration and/or high frequency cyclic on/off operation since damage from fatigue may occur. Do not use metering and pulsating type pumps. If the SUPERCHANGER unit is used in cyclic operation, the equipment should be tightened to the minimum dimension (see Table 8) to prevent fretting failure. Contact the factory for assistance.

## TIGHTENING THE PLATE PACK

The plate pack tightening length (distance between the facing surfaces of the "S" and "E" frames) is given on the assembly drawing and on the unit data plate. The tightening dimension is identified as A Max and A Min. The unit is normally tightened at the factory to the average dimension between A Max and A Min. A Min is a minimum length. Consult the SUPERCHANGER Engineering Department before tightening the unit to a smaller dimension. **CAUTION: On units operating in excess of 200 psig, the tightening dimension is to equal or approach the minimum dimension.** The wrench size required for the various SUPERCHANGER tightening bolt diameters is shown below. Refer to the SUPERCHANGER drawing for the actual bolt diameter.

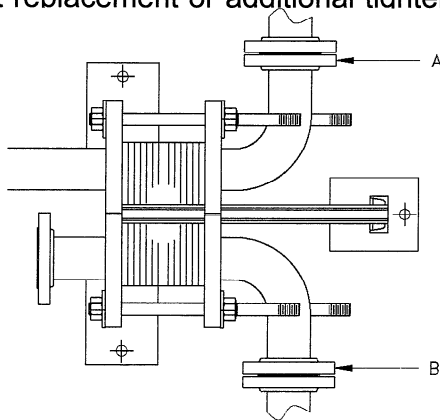
### BOLT DIAMETER

3/4"  
1"  
1 1/4"  
1 1/2"  
1 3/4"  
2"  
2 1/4"  
2 1/2"

### WRENCH SIZE (Across Flats)

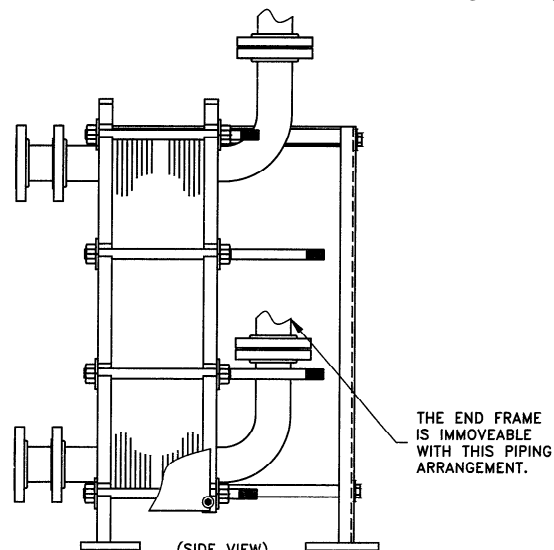
1 1/4"  
1 5/8"  
2"  
2 3/8"  
2 3/4"  
3 1/8"  
3 1/2"  
3 7/8"

Due to manufacturing tolerances, a unit is sometimes shipped with a plate pack dimension greater than the minimum dimension stated on the drawing. If leakage occurs, after a period of time, tighten the unit to the minimum length. If the plate pack length is shorter than the minimum length, damage to the plates at contact points may result. If leakage occurs at the minimum length, contact the SUPERCHANGER Engineering Department for recommendations regarding gasket replacement or additional tightening.



(Top View)  
DISCONNECTING A AND B CONNECTIONS  
WILL PERMIT MOVEMENT OF THE END  
FRAME.

Figure 25a  
Correct Piping Installation



(SIDE VIEW)  
FIGURE 25b  
INCORRECT PIPING INSTALLATION

## TIGHTENING SEQUENCE

**WARNING: DO NOT TIGHTEN THE PLATE HEAT EXCHANGER WHEN IT IS HOLDING LIQUID, UNDER PRESSURE OR OPERATING. RUPTURE OF THE GASKETS AND EXPOSURE TO PHYSICAL INJURY MAY OCCUR. ALWAYS COOL AND DRAIN THE HEAT EXCHANGER BEFORE TIGHTENING.** Figure 26a gives the tightening sequence for all units. When facing the stationary frame, tighten using the 1, 2, 3, and 4 bolts in sequence as far as possible before installing the remaining bolts. Be careful to tighten uniformly so that the moveable frame is kept parallel with the fixed frame within 1/4". Check the plate pack length on both sides of the plate pack at all tightening bolt locations. Tighten the unit, according to this procedure, to the plate pack dimension stated on the assembly drawing or unit data plate. Measure the dimension with a metal tape and tighten all bolts within 1/32" of the "A" dimension. (See Table 8).

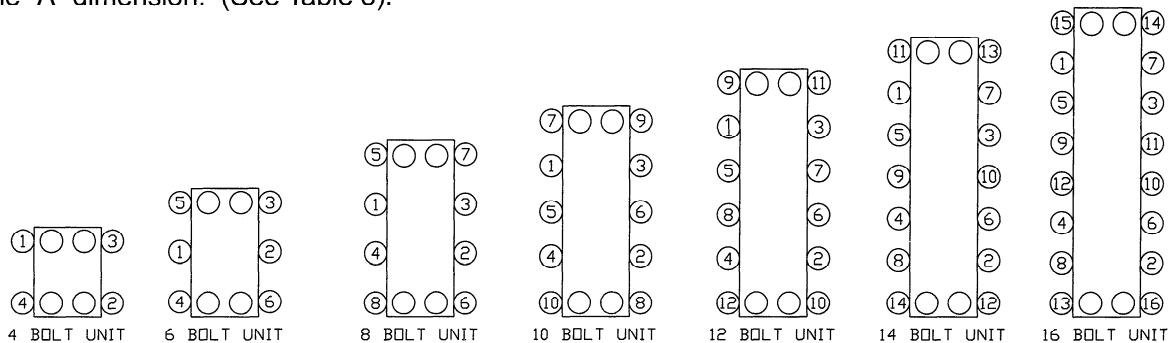


Figure 26a

## START-UP PROCEDURES

### PRECAUTIONS PRIOR TO START-UP

1. Before connecting the unit to the system, all piping must be cleaned to prevent entrance of gravel, sand, welding flux, etc. into the plate assembly. Damage to the plates and gaskets could result if the unit is contaminated with solid matter.
2. Confirm that the plate pack length is correct.
3. Open all outlet valves completely.
4. Completely close the pump discharge valves to the heat exchanger.
5. Provide venting on both sides of the heat exchanger to facilitate the removal of air from the system.
6. Start pumps and increase the pressure by opening the pump discharge valve slowly.
7. When all air is out, liquid will flow out of the vent. Close the vent.
8. Slowly and simultaneously open the inlet valves for both fluids to avoid extreme over-pressure due to hydraulic shock.
9. Control the amount of heating or cooling by using throttling valves and product thermometers in conjunction.

**CAUTION:** To reduce the possibility of water hammer, do not use fast opening and closing valves. The pressure surge caused by a sudden change in the fluid velocity can be several times higher than the normal operating pressure of the system.

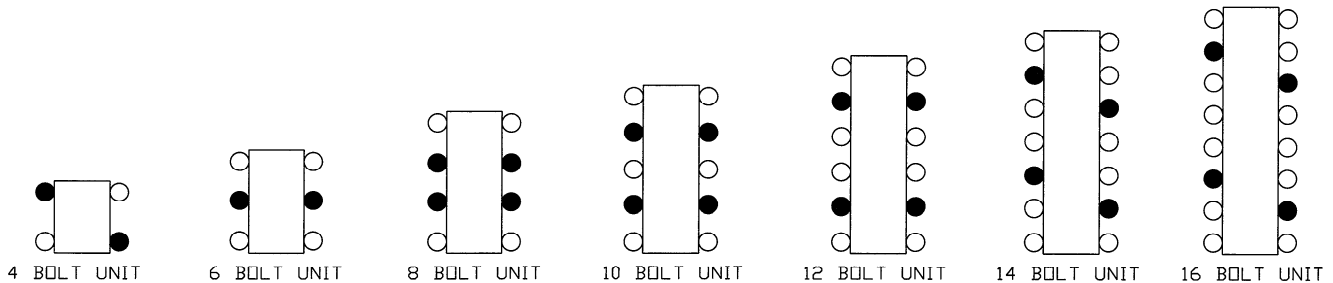
## SERVICING

### SHUTTING DOWN THE UNIT

1. GRADUALLY DECREASE THE PRESSURE OF BOTH FLUIDS SIMULTANEOUSLY UNTIL ALL PRESSURE IS RELIEVED.
2. NEVER OPEN A SUPERCHARGER UNIT WHEN IT IS HOT. COOL THE UNIT TO A WARM TEMPERATURE BEFORE OPENING TO PREVENT PERSONAL INJURY AND GASKET LOOSENING.
3. COMPLETELY DRAIN FLUIDS FROM THE UNIT.

## DISASSEMBLY PROCEDURES

To open the exchanger, it is necessary to disconnect all connections (if any) to the "E" movable frame. Lubricate all bolts prior to disassembly. Then completely loosen and remove all bolts except those indicated by a "filled circle" in the sketch below for the size unit involved. The four (4) remaining bolts can then be loosened in any left-right sequence at 1/4" increments until they can be lifted out.



**Figure 26b - Loosening Sequence**

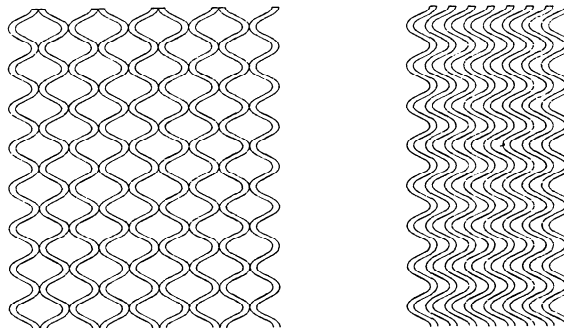
## REMOVAL OF PLATES

CAUTION: Exercise care when handling plates: the edges are sharp. Leather gloves **must** be worn.

1. Remove the plates one by one from the frame.
2. Clean and/or inspect the plates hanging in the frame by removing them one at a time.
3. To remove a plate from the frame:
  - (a) For UX-05, UX-01, UX-10, 07-S, SX-40, 14-S, GC, UFX, and TW series tilt the plate and remove it.
  - (b) S-series, UX-20, 06-T, UX-40, HVAC models 04-V, 06-V, 08-V, 11-V, and 11-T series lift the plate, push down on the hanger to release it, tilt the plate and remove it.
  - (c) UX-80 series remove the sectional guide bar track which is bolted into the bottom of the upper I beam near the movable end. Tilt the plate and remove them one at a time. (There are three of the removable track sections along the guide bar length to facilitate plate removal.)

## REPLACING PLATES

A faulty plate can easily be removed and replaced by a spare plate. Check that the new plate has the holes and gaskets arranged in the same way as the faulty one, and that the hangers are arranged in the same direction as the original installation. When the plates are properly assembled, the edges form a “honeycomb” configuration as seen in Figure 26c.



Correct

Incorrect

Figure 26c

**If a 4-hole plate is defective and no spare plate is available, the defective plate and one adjacent 4-hole plate can be removed.** The capacity of the plate heat exchanger is then reduced, but usually only slightly. When plates are removed calculate new “A” tightening dimensions from Table 8 (see page 8).

## **REPLACING GASKETS** (See Figures 3, 4, 5, 6, & 24)

### **REMOVING OLD GASKETS**

When a gasket requires replacement, steps A1, A2, and A3 may be followed or alternately steps B1, B2, and B3 may be used if facilities are available.

- A1. Remove the plate from the frame and lay it on a clean, flat, horizontal surface. Examine and note exactly how the gasket is positioned on the plate, particularly what grooves the gasket does and does not occupy.
- A2. Insert a pointed tool (screw driver) under the gasket until a finger can be inserted. Then pull slowly until the gasket is removed.
- A3. Clean the gasket groove. Adhesive residue, oil, grease and other foreign matter can be removed by applying a solvent such as Methylethyl Ketone (MEK), Acetone, or other Ketones with a nylon or stainless steel brush. Commercial paint stripping compounds are also effective in removing the gasket adhesive. Dry/wipe the gasket groove. (NOTE: Use all solvents at room temperature and in a well ventilated area not exposed to open flame, electric motors, etc.). Torches, grinding wheels and powered steel wire brushes are not to be used to remove adhesive residue since such tools will damage the plates.
- B1. When a gasket requires replacement, remove the plate from the frame and lay it on a clean, flat, horizontal surface. Examine and note exactly how the gasket is positioned on the plate, the orientation of the bleed grooves, and particularly what grooves the gasket occupies.
- B2. For gasket removal immerse the plate assemblies in a 10% to 15% caustic bath solution at 140°F to 180°F for approximately 8 hours. The caustic will soften the glue and the gaskets can be removed. Brushing with a nylon brush will help remove the softened residual glue. (NOTE: Soak time will vary depending on the type of service and the length of exposure that the plates have seen.)
- B3. The caustic solution will normally remove most of the residue scale buildup on the heat transfer surface. Brushing with a nylon brush will help remove excess residue. Always rinse thoroughly.

To remove spot-glued gaskets, follow steps A1, A2, and if necessary, step A3.

Remove scale deposits, such as calcium compounds, by immersing the plates in a 5% to 10% nitric acid solution at room temperature. This procedure must be followed by a thorough rinsing. See the section on "Plate Cleaning Tips", discussed later.

## INSTALLING GASKETS

### A. CONTINUOUSLY-GLUED GASKETS:

1. Make sure the gasket groove area is clean and dry prior to regasketing.
2. Apply a uniform layer of adhesive in the appropriate gasket grooves. (A plastic bottle makes an ideal applicator, provided the tip of the applicator is designed to provide a bead that is approximately 1/8" wide.) Do not apply adhesive in amounts that will allow it to ooze out when the gasket is pressed into the groove. Apply adhesive at room temperature. After the glue is applied to the plate, it should be allowed to set for a minimum of 30 seconds before the gasket is set in place. Work on pairs of plates to allow for this curing time.

The recommended adhesive for all elastomeric gaskets is Pliobond 30. Pliobond 20, Henkel 4330, and Silaprene 6249 can also be used, if Pliobond 30 is not available. Hardening adhesives are not to be used. The number of gaskets which can be glued from one pint bottle of Pliobond 30 glue may be approximated as follows:

MODEL	NUMBER OF GASKETS/PINT	MODEL	NUMBER OF GASKETS/PINT
UX-05	122	UFX-51, GC-51	17
UX-01	100	UFX-37	30
UX-10	85	UFX-64	18
UX-20, 04-V	60	UFX-91	15
S-3	50	UFX-118	13
06-T, 07-S	35	UFX-60, GC-60	20
06-V, 07-V	35	UFX-100	18
UX-40, 08-V	30	UFX-140	14
11-T, 11-V	30	UFX-180	15
SX-40, 10-V, 14-S, 14-V	30	UFX-85	16
S-8	25	UFX-145	14
UX-80, 18-V	10	UFX-205	12
UFX-06	50	UFX-265	10
UFX-12	50	UFX-325	8
UFX-18	35	TW-05	19
UFX-26, GC-26	30	TW-10	18
UFX-42	20	TW-18	15

## **A. CONTINUOUSLY-GLUED GASKETS: (cont.)**

3. Position the gasket on the plate making sure that the recess in the gasket at the bleed passage location is up. Also, when the proper side is up, the gasket code number will be visible in the bleed passage area. Proper groove fit and flow diverter access is dependent on end-to-end positioning. (See Figures 13a and 23a).
4. Using finger pressure, firmly press the gasket into the same grooves from which the original gasket was removed.
5. Compress the gasket by placing the plate under a weighted sheet of wood. The longer the compression time, the better the bond. Twelve (12) hours cure time at room temperature (70°F) should be allowed to assure minimum required adhesion of the gasket to the plate for all elastomers except EPDM. EPDM gaskets require a minimum of twenty-four (24) hours cure time at room temperature (70°F) to assure an adequate bond. (When several plates are being gasketed, they can be stacked on top of each other with the weighted wood sheet placed on the top plate of the stack.)
6. After compression time (step 5), use solvent to remove any excess adhesive that may have seeped out past the edges of the gasket.
7. Reinstall plate(s) in unit insuring that the gasket surface and the sealing surface of the plate ahead are wiped clean to provide a positive seal.
8. Note that the "D" plate (always the plate next to the fixed frame end) requires different gaskets. The purpose of the "D" plate is to prevent fluid from flowing across the fixed end frame. The only sealing surface on the "D" plate is the port hole gaskets. "D" plate gaskets for the UX series consist of two half gaskets.

"D" plate gaskets for the "S" series consist of four (4) port hole gaskets and straight strips which fit in the gasket groove around the periphery of the plate. The wide port gasket fits the widest groove and the narrow port hole gasket fits the narrow groove.

**NOTE:** Refer to page 23 when using mixed gaskets.

## **B. SPOT-GLUED® GASKETS:\***

In the following procedure, after the glue is applied to the plate at the appropriate spots, allow it to set for a minimum of 30 seconds before the gasket is mounted. Work on pairs of plates to allow for this curing time. Work in a well-ventilated area.

1. Clean the gasket groove in one plate with a rag moistened with Methyl Ethyl Ketone (MEK).

**B. SPOT-GLUED® GASKETS\*:** (cont.)

2. Apply a 1/8" diameter spot of Pliobond 30 approximately every 4 inches centered in the gasket groove of the plate just cleaned.
  - a) Apply the glue so there are no thin spots.
  - b) Apply spots of glue at the "T" joints (see Figure 19d).
3. Clean the groove of a second plate, as in Step 1.
4. Apply adhesive to the second plate, as in Step 2.
5. Install the gasket on the first plate. Make sure the gasket is oriented as shown in Figures 13a and 23a.
6. Install the gasket on the second plate, as in Step 5.

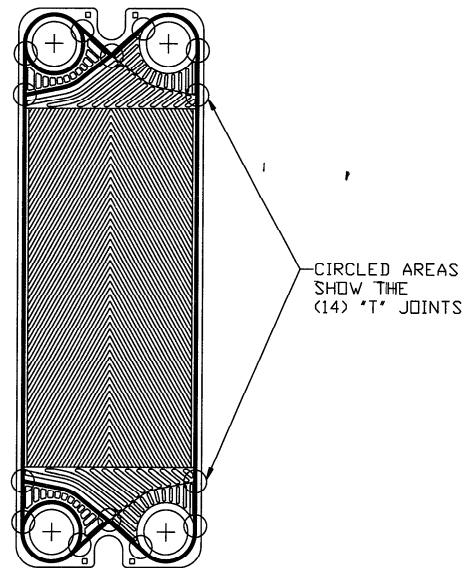
**NOTE:** The purpose of working with two plates simultaneously is to allow the adhesive to set for a minimum of 30 seconds before the gasket is applied. When working with small plates, a third plate can be incorporated into the above procedure to obtain set time. **The curing time must not exceed 3 minutes.**

7. Compress the gasket by placing the plate under a weighted sheet of wood. The longer the compression time, the better the bond. Twelve (12) hours cure time at room temperature (70°F) should be allowed to assure maximum adhesion of the gasket to the plate for all elastomers except EPDM. EPDM gaskets require a minimum of twenty-four (24) hours cure time at room temperature (70°F) to assure an adequate bond. (When several plates are being gasketed, they can be stacked on top of each other with the weighted wood sheet placed on the top plate of the stack.)
8. After adequate compression time, use solvent to remove any excess adhesive that may have seeped-out past the edges of the gasket.
9. Reinstall plate(s) in unit insuring that the gasket surface and the sealing surface of the plate ahead are wiped clean to provide a positive seal.

**NOTE:** Refer to page 23 when using mixed gaskets.

\*Spot gluing of Elastomeric gaskets is covered under Tranter's U.S. Patent #5070939.

**Figure 26d**



**C. SUPERLOCK® SNAP-IN GASKETS:\***

1. Position the gasket on the plate making sure that the recess in the gasket at the bleed passage location is up. When the proper side is up, the gasket code number will be visible in the bleed passage area. Correct end-to-end position is also important for a proper groove fit and fluid access to the flow diverter. (See Figures 13a & 23a.)
2. Make sure that the tabs of the SUPERLOCK gaskets are lined up with the slots in the gasket groove of the plate.
3. Insert each tab inside its corresponding slot and push firmly until the tab locks into the slot. Make sure that each of the porthole tabs (located in the bleed port area towards the middle of the plate) is also snapped into its slot.

**NOTE:** Refer to page 23 when using mixed plates.

\*SUPERLOCK gaskets are covered under Tranter's U.S. Patent #4995455.

**D. TEFLON ENCAPSULATED GASKETS AND UNIT ASSEMBLY:**

**CAUTION:** Do not tighten below the average dimension shown on the assembly drawing.

1. Install double-sided tape in the center of the gasket groove. Use continuous strips. Do not contaminate the tape surface.
2. Do not overlap tape strips as this will cause leakage in that area.
3. Install Teflon such that bleed ports (notches) in each section in rubber core are installed in the up position.

#### **D. TEFLON ENCAPSULATED GASKETS AND UNIT ASSEMBLY: (cont.)**

4. Install plates per the assembly drawing that is received with the unit.
5. Check top surface of Teflon and gasket seal surface for cleanliness.
6. Install all bolts and tighten the unit (snug tight only).
7. Refer to page 27 for tightening sequence.
8. Tighten unit in 1/16" increments to ensure even compression of gaskets.
9. Tighten to maximum dimension as shown on assembly drawing.
10. Single side hydrostatic test to design pressure shown on assembly drawing.
11. Double side hydrostatic test to test pressure shown on assembly drawing.
12. If unit leaks during either of the above tests, run 150°F - 170°F hot water for one (1) hour. Let the unit cool and tighten to average dimension as shown on assembly drawing using same increments as in step 9.
13. Re-conduct the hydrostatic test.
14. If unit still leaks, mark plate and area of leakage.
15. Disassemble unit and check gasket and seal surface for defects, especially at the leakage sites. If no apparent defect is found, apply an even thin layer of "Teflon TFE Pipe Thread Sealer" furnished by McMaster Carr (Cata. 96, page 1362, part #4538K1) to teflon gasket at leakage site.
16. Retighten unit using same procedure as listed above.
17. Re-conduct the hydrostatic test.
18. Unit should not seal. If unit is still leaking, contact the factory.

**NOTE:** Refer to page 23 when using mixed gaskets.

## **CLEANING**

SUPERCHANGER plate and frame type heat exchangers are designed for both manual cleaning and cleaning-in-place operations. Where possible, utilize a cleaning-in-place system which will allow pumping water or cleaning solutions into the unit without disassembling. If this is not possible, use the manual method. Descriptions of the two cleaning procedures follow.

## STEPS FOR MANUAL CLEANING OF PLATES

1. Open the unit in accordance with disassembly procedures on page 28.
2. Clean each plate separately. Depending upon the amount of cleaning to be performed, the plate can be cleaned while still hanging in the unit or removed, placed on a flat surface and cleaned.
3. NEVER USE A STEEL BRUSH OR STEEL WOOL ON THE PLATES. If a brush is required, use one with bristles that are softer than the plate material. If iron is forcibly rubbed on a stainless steel surface, it is impossible to remove all imbedded particles and will result in accelerated rusting and/or corrosion. If it is absolutely necessary that a metal brush be used, the brush material must be compatible with the plate material.
4. Be careful not to scratch the gasket surfaces.
5. After brushing, each plate should be rinsed with clean water.
6. Use high pressure rinse when cleaning continuously glued plate assemblies.
7. See "Plate Cleaning Tips" on page 37 for specific types of deposits.
8. THE GASKETS MUST BE WIPED DRY WITH A CLOTH. Solid particles adhering to the gaskets cause damage and result in leakage when the unit is put back in operation.
9. The lower portion of each plate as hung in the unit should be inspected carefully and cleaned appropriately as this is the primary area where residual solid material tends to accumulate.
10. Wipe off the mating surface, i.e.; the rear of the plate where the gasket seats.
11. Upon completing the cleaning, inspection and installation of each plate, the unit may be closed, tightened per the assembly drawing and the tightening instructions (page 27), and placed into operation.

**CAUTION:** Do not use chlorine or chlorinated water to clean stainless steel, Hastelloy, Incolloy, Inconel and 254SMO. Chlorine is commonly used to inhibit bacteria growth in cooling water systems. It reduces the corrosion resistance of stainless steel, Hastelloy, Incolloy, Inconel and 254SMO. The "protection layer" of these steels is weakened by chlorine and makes them more susceptible to corrosion. This increase in susceptibility to corrosion is a function of time and the chlorine concentration. For any applications where chlorination must be used with non-titanium equipment, please contact the factory.

## PLATE CLEANING TIPS

1. Do not use hydrochloric acids, or water containing in excess of 300 ppm chlorides, with stainless steel.
2. Do not use phosphoric or sulfamic acid for cleaning titanium plates.
3. Limit cleaning solution concentration to 4% in strength, with temperatures not exceeding 140°F unless otherwise specified.

General guidelines for cleaning are tabulated below. (Please refer to notes (1) through (3) above for precautions.)

<u>Type of Fouling</u>	<u>Suggested Cleaners</u>
Calcium Sulphate, Silicates	Citric, Nitric, Phosphoric or Sulfamic Acid
Calcium Carbonate	10% Nitric Acid (1 volume concentrated Nitric Acid with specific gravity 1.41 to 9 volumes of water), Oakite 131
Alumina, Metal Oxides, Silt	Citric, Nitric, Phosphoric, or Sulfamic Acid. (To improve cleaning add detergent to acid.)
Barnacles, Mussels, Seaweed, Wood Chips	Back flush per cleaning-in-place procedure below Figure 27
Biological Growth	Sodium carbonate or sodium hydroxide

## CLEANING-IN-PLACE (CIP)

Cleaning-in-place is the preferred cleaning method when especially corrosive liquids are processed in a SUPERCHANGER unit. Install drain piping to avoid corrosion of the plates due to residual liquids left in the unit after an operation cycle. (See Figure 27).

To prepare the unit for cleaning, follow the procedures listed below:

1. Drain both sides of the unit. If it is not possible to drain, force liquids out of the unit with flush water.
2. Flush the unit on both sides with warm water at approximately 110°F until the effluent water is clear and free of the process fluid.
3. Drain the flush water from the unit and connect CIP pump. (See pages 36 - 38 for suggested cleaners.)

## CLEANING-IN-PLACE (cont.)

4. For thorough cleaning it is necessary to flow CIP solution bottom to top to insure wetting of all surfaces with cleaning solution. When cleaning multiple pass units it will be necessary to reverse flow for at least 1/2 the cleaning time to wet all surfaces.
5. For optimum cleaning, use the maximum flow rate of water, rinse, or CIP solution that the CIP nozzle size will allow (2" @ 260 GPM, 1" @ 67 GPM.) A CIP operation will be most effective if performed on a regularly scheduled basis and before the unit is completely fouled.
6. Flush thoroughly with clean water after CIP cleaning.

IF BRINE IS USED AS A COOLING MEDIUM, COMPLETELY DRAIN THE FLUID FROM THE UNIT AND FLUSH THE UNIT WITH COLD WATER PRIOR TO ANY CLEANING OPERATION. CORROSION WILL BE KEPT AT A MINIMUM IF ALL TRACES OF BRINE ARE ELIMINATED BEFORE USING HOT CIP SOLUTIONS ON EITHER SIDE OF THE HEAT EXCHANGER.

Figure 27

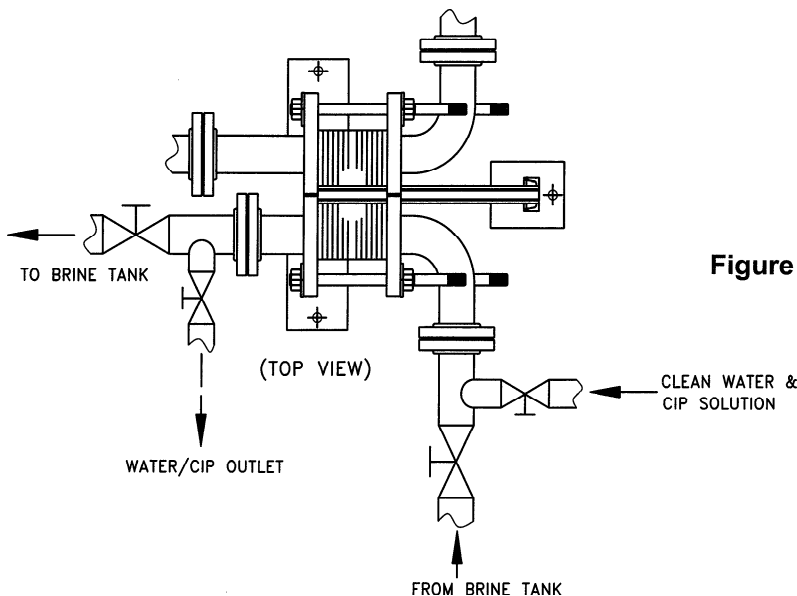
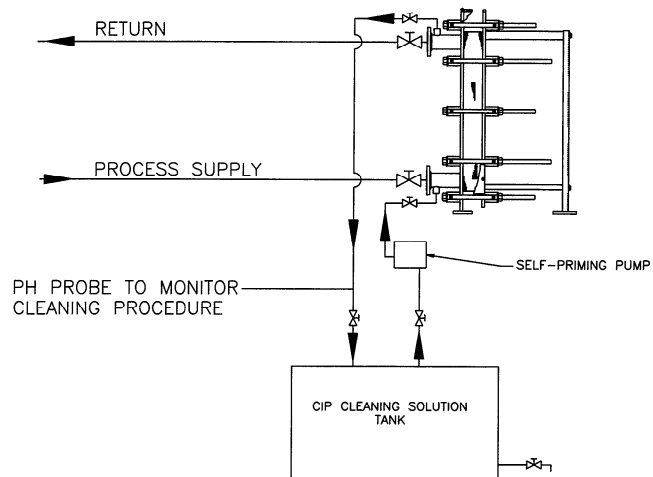


Figure 28 - Piping using brine

## BACK FLUSHING AND STRAINERS

Often, when fibers or large particulates are present, back flushing of the unit proves to be very beneficial. This is accomplished by either of the following methods:

1. Flush the unit with clean water in reverse flow to the normal operating direction.
2. Arrange piping and valves so the unit may be operated in reverse flow mode on the product side for fixed periods of time. This method is particularly well suited for steam-to-product units.
3. The use of strainers are recommended in supply lines ahead of the exchanger when the streams contain significant solids or fibers. This will reduce the requirements for back flushing.

## CLEANING GUIDELINES

1. Never open the unit when hot, under pressure, holding liquid or operating.
2. Never clean the plates with a steel brush or steel wool.
3. Always wipe the gaskets clean before closing the unit to prevent damage resulting from adhering particulate matter.
4. Always use clean water (free from salt, sulphur, chlorine or high iron concentrations) for flushing and rinsing operations.
5. If steam is used as a sterilizing medium, do not exceed 270°F steam temperature with nitrile gaskets, and 350°F with EPDM gaskets.
6. If chlorinated solutions are used as the cleaning media, employ a minimum concentration at the lowest temperature possible. Minimize the plate exposure time. The chlorine concentration must be less than 100 PPM and temperatures must be under 100°F with a maximum plate exposure time of 10 minutes. Follow the cleaning recommendations of suppliers, relative to concentration, temperature and treatment time.
7. Always add concentrated cleaning solutions to water before circulating through the unit. Never inject these solutions while the water is circulating.
8. Remove rusted or pitted areas that appear on the plates with commercial scouring powder. Follow this by flushing with clean water.
9. Cleaning solutions should always be circulated with a centrifugal pump.
10. Do not use hydrochloric (muriatic) acid for cleaning plates.
11. Thoroughly rinse the plates with clean water following any type of chemical cleaning.

# TROUBLE-SHOOTING

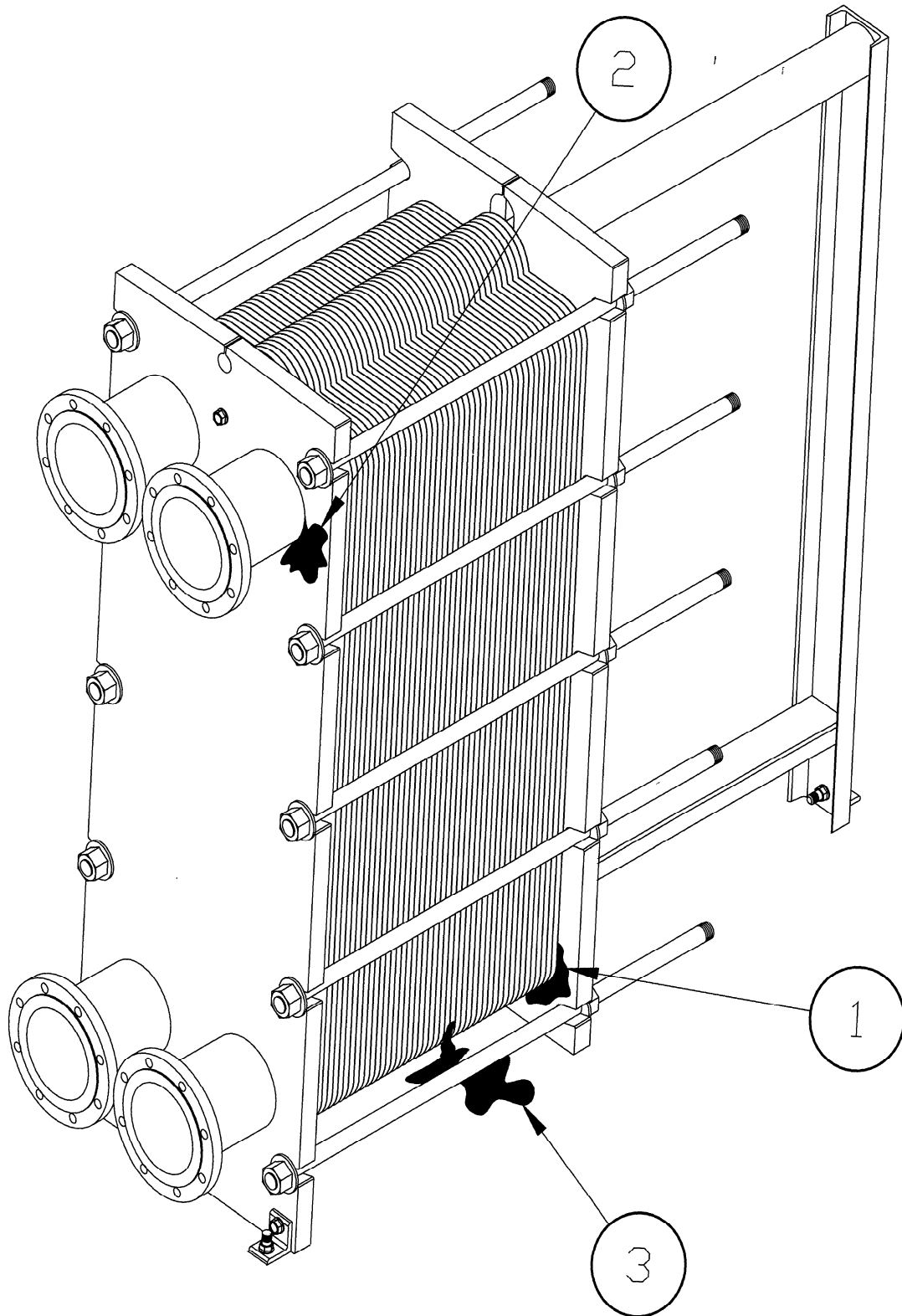


Figure 29

## LEAKAGE BETWEEN THE PLATE PACK AND THE FRAME

(See Figure 29, Item 1)

### PROCEDURES & OBSERVATIONS

1. Use a felt tip marker to identify the area where the leakage seems to be occurring and then open the plate pack.
2. If the leakage occurs in the area of a nozzle, then observe the gasket condition of the "D" plate or "E" nozzle "O" ring. Foreign matter, scars, other damage to the gasket surfaces, and any gasket dislocation may be the problem.
3. Check the end frame for foreign objects, surface unevenness, or any other condition which might interfere with the seal between the gasket and the adjacent surface.
4. Check the plate for cracks or holes.

### SOLUTIONS

- Remove all foreign matter, relocate the gasket, or replace the damaged gasket.
- Remove any interference between the gasket and the surface of the end frame.
- If a plate has perforation, it must be replaced.

## LEAKAGE BETWEEN THE NOZZLE AND THE END FRAME

(See Figure 29, Item 2)

### PROCEDURES AND OBSERVATIONS

1. Fluid is flowing from the area between the nozzle and the end frame (point A on Figure 30) and/or the interior of the end frame and the seal plate (point B on Figure 30).

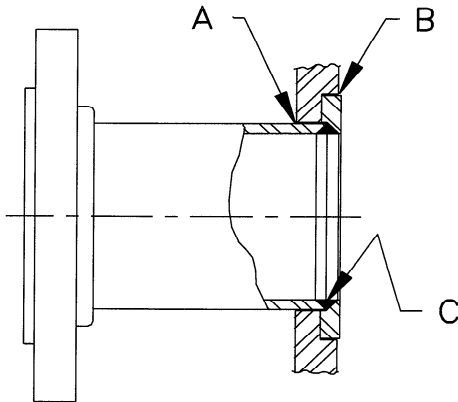


Figure 30

### SOLUTIONS

Check the integrity of the continuous pressure weld between the stub end and the seal point (point C on Figure 30). Dye-check for small cracks. If the dye-check reveals any linear indication, the area needs to be ground down and re-welded using TIG welding, and the appropriate welding wire. If the weld damage occurred due to a blow to the nozzle, some of the plate assemblies may be damaged. Damaged plates should be replaced.

# LEAKAGE BETWEEN THE PLATES TO THE OUTSIDE OF THE UNIT

(See Figure 29, Item 3)

## PROCEDURES AND OBSERVATIONS

1. Mark the area of the leak with a felt tip marker.
2. Check the plate pack dimensions to insure they agree with Table 8, page 9. Overtightening may cause plate damage.
3. Look for mislocated, loose, or damaged gaskets.
4. Check for plate damage in the area.
5. Make sure the plate pack sequence is A-B-A-B-etc., see Figure 13.

## SOLUTIONS

Depressurize unit and adjust the plate pack as necessary. Disassemble unit per procedure on page .

Relocate gaskets, reglue loose gaskets, and replace damaged gaskets.

A damaged plate usually must be replaced. For temporary duty, if the damaged plate has four holes, and an adjacent plate (front or back) has four holes, remove both plates and retighten the plate pack according to Table IV. Contact the factory if temporary operating characteristics need to be developed for a smaller number of plates. See "How to Find a Defective Plate" on page 43.

Inspect the plate pack for damage and place the plate assemblies in the correct order.

## MIXING OF FLUIDS

### PROCEDURES AND OBSERVATIONS

1. Make sure the piping is connected to the correct locations on the heat exchanger.
2. Make sure the plates are properly arranged on each adjacent plate according to the assembly drawing. (A-B-A-B...arrangement)
3. Make sure the gaskets are correctly oriented on the plates with the "bleed port" of each gasket facing away from the plate surface. See Figures 23a through 23c.
4. Follow the steps described in "How to Find a Defective Plate" on page 43. If a leak is found, use a felt tip marker to locate the place.

### SOLUTIONS

Relocate piping to the correct connections.

Open the plate pack and replace the plate gasket assembly.

Replace gaskets correctly.

Remove and replace as discussed on page 30.

# INCREASE IN PRESSURE DROP OR A REDUCTION IN TEMPERATURE READINGS

## PROCEDURES AND OBSERVATIONS

## SOLUTIONS

1. The pressure drop from the inlet to the outlet on one or both sides of the unit is too high compared to the original specified pressure change.

Try cleaning-in-place (CIP) as described in Figures 27 and 28. Check the accuracy of the instrumentation. Pressure taps should be installed 10 and 5 pipe diameters upstream and downstream, respectively, from flow disturbing source, e.i; elbow, valve, reducer, etc.

2. The temperature readings are correct for the process, however, the pressure drop is high.

The plate surfaces are clean enough, however, the inlet of the unit could be clogged. Back flushing the equipment or CIP may solve the problem.

3. The temperature readings do not correspond to the original temperature settings or specifications.

The pressure drop is probably also increasing. The change in the temperature readings indicates that there is a buildup of deposits on the plate surfaces. If CIP or back flushing the equipment does not work, the unit will need to be opened and the plates cleaned.

4. The pressure drop is too low and the unit is known to be clean.

The pump capacity may be too small. Check the pump manual.

## HOW TO FIND A DEFECTIVE PLATE WITH THROUGH HOLES

Severe corrosion may cause defect to occur. The following method is recommended to determine the location of the defective plate or plates:

1. Open the unit, remove all fouling from surfaces and dry the plates after cleaning. Make sure the bleed port area (see Figure 23a on page 23) are clear.
2. After completely drying the plates, reassemble the unit.
3. Supply water to one side (side A) and raise the water pressure to approximately 50 psig.
4. Open the drain valve at the lowest point or break the flange on side B. By removing the flange and fittings, it is possible to look into the nozzle and measure to the exact leaking plate.
5. Stop the test if water flows out of the drain valve or flange on side B.
6. Open all valves and empty the unit of all water.

## HOW TO FIND A DEFECTIVE PLATE WITH THROUGH HOLES (cont.)

7. Open the unit promptly and find which plate is wet on side B. This plate and the preceding plates may have defects.
8. The defect can be found by placing a lamp on the rear side of the plate and by observing the light that passes through.
9. If the defect is small, the use of dye penetrant may be required to locate the defect. Because of the metal to metal contact of the plates, the defect can be larger when the plate pack is compressed than when it is in the free state.

**NOTE:** A unit with multiple pass circuits that does not allow the fluid to drain out of each channel on one side cannot be tested in this way unless the special center plates are first removed. See Figure 16 on page 15 as an example.

## STORAGE PROCEDURES

When a SUPERCHANGER plate and frame heat exchanger is to be placed in storage for six months or longer, the procedures listed below must be followed:

1. If the unit has been recently shipped from our factory and is unused, disregard statements 2, 3, and 4; follow instructions 5-10.
2. If the unit has been used and long-term storage is required, it must be completely drained. Prior to draining remove the optional shroud, if provided, and let the unit cool to ambient temperature. Units with plate packs arranged with one pass on each side (all nozzles on the stationary end frame) are self-draining. Simply vent at the upper nozzle location and drain from the lower nozzle for each side individually. A two pass/two pass or one pass/two pass plate arrangement is also self-draining, provided all two pass side nozzles are at the lower elevations (numbers 3, 4, 7 and 8). Other units may be self-draining if they have been fitted with separate drain and vent nozzles, or with vents and drain holes. Units that are not self draining must have the plate pack completely loosened to drain all liquids. Before opening the plate pack, wipe off the exterior surfaces to make sure no fluids or debris fall onto the plate pack.
3. Open the plate pack and thoroughly clean the unit internally and externally. Dry the unit. (Blowing dry, hot air at approximately 150°F on all areas is an excellent method.)
4. Install blind flanges with gaskets on all nozzles. Plug all other openings.
5. Coat all unpainted carbon steel component surfaces with light grease, SAE 30 oil, or other rust inhibiting products.
6. Coat all bolt threads with light grease.

## **STORAGE PROCEDURES (cont.)**

7. To minimize gasket compression set, the plate pack length dimension needs to be adjusted. This must be greater than the unit's stated minimum tightening dimension (T.D.). As a guideline, the unit's minimum tightening dimension should be increased by a factor of 1.20 (e.g. 50" T.D. x 1.20=60"). When preparing the unit to go back into service, check to ensure that it is retightened to its original T.D.
8. Protect the unit from direct sunlight, intense heat radiation, or ultraviolet radiation by loosely covering the unit with an opaque, reflecting type plastic film or similar material. Make sure air is allowed to circulate around the unit.
9. It is preferable to store the unit indoors, well protected from the weather. The temperature in the storage area should ideally be 60°F to 70°F with a relative humidity of 70% or lower.

**NEVER STORE THE UNIT IN AN AREA WHERE THE TEMPERATURE IS AT 32°F OR LOWER.**

10. All potential sources of Ozone, such as operating electric motors, or welding equipment, should be removed from the storage area to preclude Ozone attack on gaskets. Gaskets should not be exposed to direct sunlight (ultraviolet radiation) and should be stored in dark plastic bags. Under proper storage conditions, gaskets generally have a shelf life of approximately four years.

## **MISCELLANEOUS INSTRUCTIONS**

### **GENERAL MAINTENANCE**

It is recommended that tightening bolts and tightening nuts be lubricated periodically in order that they can be easily loosened at time of disassembly. The upper guide bars where the plates slide should be coated with a lubricant to avoid corrosion and to enable the plates to slide smoothly. Rollers in the moveable end frame and connecting frames should be lubricated with oil periodically.

### **ORDERING PARTS**

When ordering parts or requesting information, always give the Model and Serial Number of the unit.

Refer to the parts list on your assembly drawing for correct nomenclature and numbers.

# **MISCELLANEOUS INSTRUCTIONS** (cont.)

## **RETURNED MATERIAL**

Units or parts are not to be returned without first obtaining permission. Parts accepted for credit are subject to a service charge plus all transportation charges. Any items authorized for return must be adequately packed to reach TRANTER, inc., Texas Division, at the address shown below without damage.

## **DAMAGED SHIPMENTS**

Tranter, inc.'s equipment is carefully packaged at the factory to protect it against the normal hazards of shipment. If Tranter, inc. equipment should arrive in a damaged condition, the customer must file a damage report with the carrier. A copy of this claim should be sent to:

TRANTER, inc.  
TEXAS DIVISION  
1900 OLD BURK HIGHWAY  
WICHITA FALLS, TX 76306

## **ADDITIONAL INFORMATION**

For any additional information concerning the operation, care or maintenance of your SUPERCHANGER, feel free to contact our SUPERCHANGER technical specialists at the address indicated above or call at (940) 723-7125. Our FAX number is (940) 723-5131.

# Superchanger

SUPERCHANGER units are plate and frame type heat exchangers consisting of corrugated heat transfer plates, frames, nozzles and tightening bolts. The corrugated plates are held in between the stationary and moveable frames and are compressed by tightening bolts. Optional shrouds are available on request.

The plates are equipped with elastomeric gaskets and have port holes pierced in the corners. When the unit is tightened, the gaskets seal the structure and, in conjunction with the port holes, allow fluids to flow in alternate channels and almost always flow counter-currently.

The thin fluid interspace coupled with the corrugated plate design induces turbulence that produces extremely high heat transfer coefficients.

Plates are manufactured in standard sizes in virtually any material that can be cold worked. The size, number and arrangement of the plates is contingent upon the duty to be performed. Accordingly, the units are custom designed for each application.

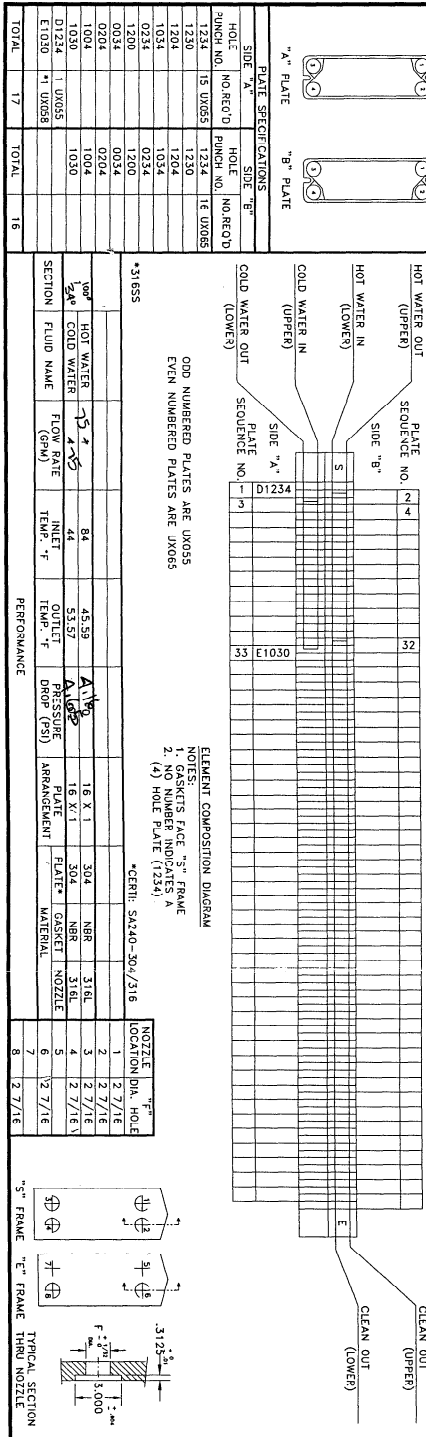
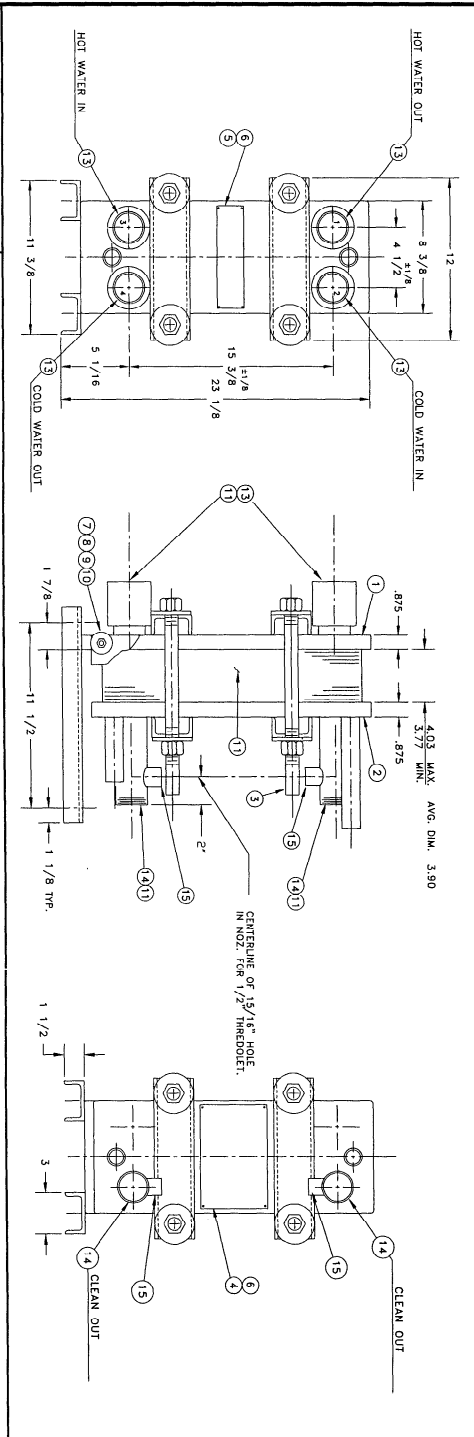
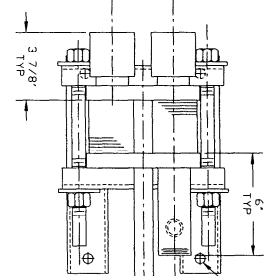
SUPERCHANGER frames are provided in two basic designs, differing primarily in their support systems. One type uses

an external support column (Models HP, UP, SP, MP and FP) while the other type uses a self-contained supporting pad (Models HJ, UJ, SJ and MJ). The "J" Models conserve more space, but have a limited plate capacity while the "P" Models can contain up to 640 plates in a single frame. See figures 1 and 2.

**Information in this brochure is subject to change without notice. The manufacturer reserves the right to change specifications at any time.**



TRANTER, inc. ▲ Texas Division ▲ P.O. Box 2289  
1900 Old Burk Highway ▲ Wichita Falls, Texas 76307  
Telephone: (940) 723-7125 ▲ Fax: (940) 723-5131  
<http://www.tranter.com>



ITEM NO.	DESCRIPTION	DRAWING NO.	NO. REQ'D.
1	STATIONARY FRAME ASS'Y	SA-675-70	1
2	MOUNTABLE FRAME ASS'Y	SA-675-70	1
3	BOLT ASS'Y (VARIABLE LENGTH)	SA-193-B7	1
4	DATA NAMEPLATE	B-202056-1	1
5	METAL TACK FASTENER	A-203187	8
6	SHROUD STUD	A-200830	N/A
7	SHROUD NUT	A-200831	N/A
8	SHROUD WASHER	A-200832	N/A
9	THREAD PROTECTOR	A-38976	6
10	PLATE (SEE TABLE)	SA312-19318L	33
11	NOZZLE 2" SDR (S. FR.)	SA312-19318L	4
12	NOZZLE 2" SDR (E. FR.)	SA312-19318L	2
13	NOZZLE 2" SDR (S. FR.)	SA312-19318L	2
14	NOZZLE 2" SDR (E. FR.)	SA312-19318L	2
15	2 1/2" x 3 1/2" 300# THREADED SA192-318L	D-202590-22	2

SPECIFICATIONS		"U" CODE STAMP DATA	
DESIGN PRESSURE :	150 PSIG	TEST PRESSURE :	195 PSIG
DESIGN TEMP. :	200 °F	NO. OF PLATES :	33
SURFACE AREA :	19.2 SQ. FT.	WEIGHT :	153 LBS
NOZZLES WITH N.P.T. ONE END :	4	PAINT :	ROYAL BLUE

PLATE SPECIFICATIONS		ELEMENT COMPOSITION DIAGRAM	
HOLE NO. REQ'D	PLATE NO.	SEQUENCE NO.	NO.
15 UX055	1204	1	5
1204	1204	2	5
1034	1034	3	5
0234	0234	4	5
1200	1200	5	5
0204	0204	6	5
1004	1004	7	5
1034	1034	8	5
1 UX055	1030	9	5
1 UX055	1030	10	5
TOTAL	17	TOTAL	16