

Technical Training Handbook and Reference Guide



**Technical Training Handbook
and
Reference Guide**

**Section 8 :
Skillets**

Skillets

Table of Contents

• Power Jack Assemblies	1
• SET 15	2
• SEL TR	5
• SEL T1	14
• SGL TR	20
• Ignition Module Kit	29
• SGL T1	34
• Gas Valve Kit	39
• Flue installation Kit	40

POWER JACK ASSEMBLY

Model	Production Dates	Jack Assembly #	Motor #	Id Factor
SEL	Oct. 83 to Nov 89	SK50145	SE50004	22"-115VAC-Gear Box
SEM	Oct. 83 to Nov 89	SK50145	SE50004	22"-115VAC-Gear Box
SEL-X	Nov 89 to Sept 91	SK50493	SE50025	17"-115VAC-Chrome Shaft
SEM-X	Nov 89 to Sept 91	SK50493	SE50025	17"-115VAC-Chrome Shaft
SEL-T	Sept. 91 to July 93	078192-1	078192-2	24VDC Pancake Motor
SEM-T	Sept. 91 to July 93	078192-1	078192-2	24VDC Pancake Motor
SEL-R	July 93 to Present	2346100	N/A	24VDC Plastic Housing
SEM-R	July 93 to Present	2346100	N/A	24VDC Plastic Housing
SGM	Oct. 83 to Feb 87	SK50314	SE50025	19"-115VAC
SGL-X	Feb 87 to Dec 90	SK50493	SE50025	17"-115VAC-Chrome Shaft
SGM-X	Feb 87 to Dec 90	SK50493	SE50025	17"-115VAC-Chrome Shaft
SGL-T	Nov. 89 to Feb 93	078192-1	078192-2	24VDC Pancake Motor
SGM-T	Nov. 89 to Feb 93	078192-1	078192-2	24VDC Pancake Motor
SGL-R	Feb 93 to Current	2346100	N/A	24VDC Plastic Housing
SGM-R	Feb 93 to Current	2346100	N/A	24VDC Plastic Housing

"SPLASH PROOF"

*ELECTRIC TABLE TYPE, ROUND,
15 GALLON (56 LITER)*

MODEL: SET-15

Cleveland Standard Features

- High Efficiency Heating System with even heat distribution via Heating Elements cast into Aluminum, covering entire pan bottom
- Cooking Surface Guaranteed against warping
- Splash Proof
- Bead Blasted Cooking Surface resists sticking
- Adjustable, Thermostat Controlled Temperature from 175°F to 425°F
- Fast Heat-Up and Recovery Time
- Balanced Design Permits Easy Tilting; with left or right mounted Tilt Handle
- All Stainless Steel Construction for durability and easy cleaning
- Lift-Off Cover with Adjustable Vent
- Sanitary Base Mounting for Table Top Installation
- Standard 208 or 240 Volts, 60 Hz, 3 Phase, 3 Wire
- Self-Locking Marine Type Tilt Mechanism: Prevents accidental tilting
- Typical approvals include UL, CSA, CE and NSF

Options & Accessories

- Double or Single Pantry with Swing Spout (DPS) or (SPS)
- Faucet Bracket (FBSL)
- Poaching Pan (PPR)
- Vegetable Steamer (VS)
- 4" Stainless Steel Legs with adjustable feet (LTKS)
- Stainless Steel Support Stands (ST28) with Sliding Drain Drawer and Splash Screen
- Food Strainer (FS-15-5)
- 240 Volts, 60 Hz, 3 Phase (VOSK1)
- 380/415 Volts, 50 Hz, 3 Phase - For Export (VOSK2)
- 440/480 Volts, 60 Hz, 3 Phase (VOSK3)
- Single Phase Option (SPH)



Shown with optional Support Stand (ST28)

Short Form Specifications

Shall be CLEVELAND, Round Tilting Skillet, Model SET-15; ____ KW ____ Volts, 15 Gallon Capacity (56 liters). Complete with: Thermostatic and Safety Controls; Bead Blasted Cooking Surface; Lift-Off Cover with adjustable Vent. All Stainless Steel Construction.



CAPACITIES

In 4 oz. servings. Other sizes may be calculated.
 15 gallons / 56 Liters 480

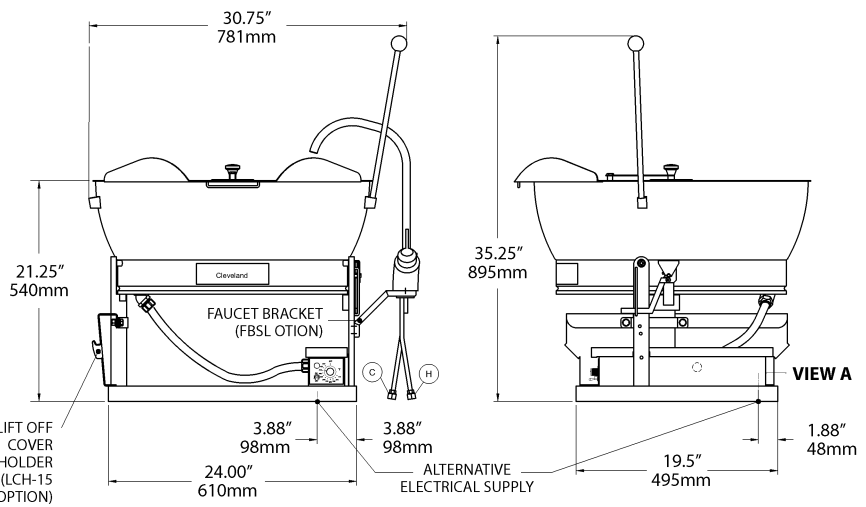
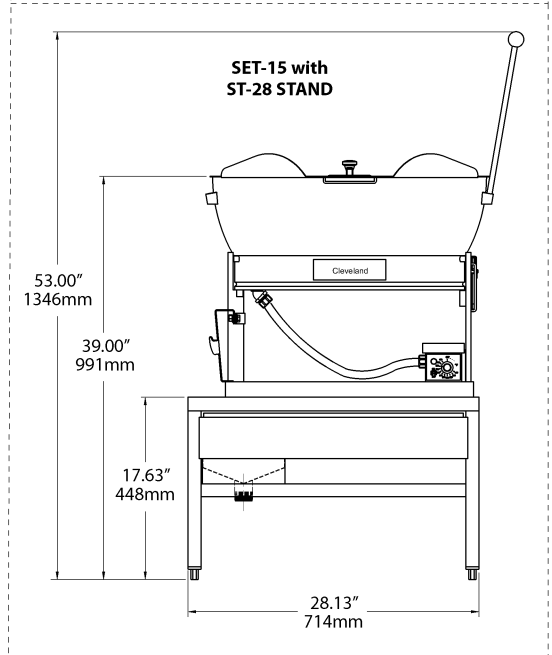
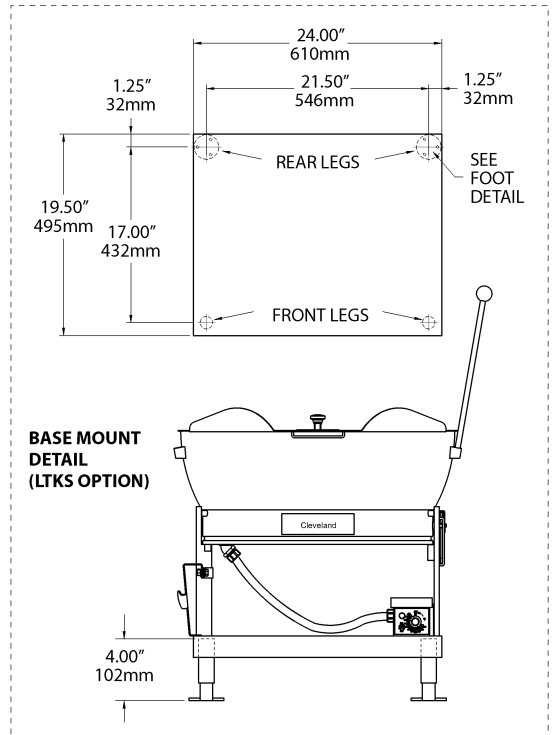
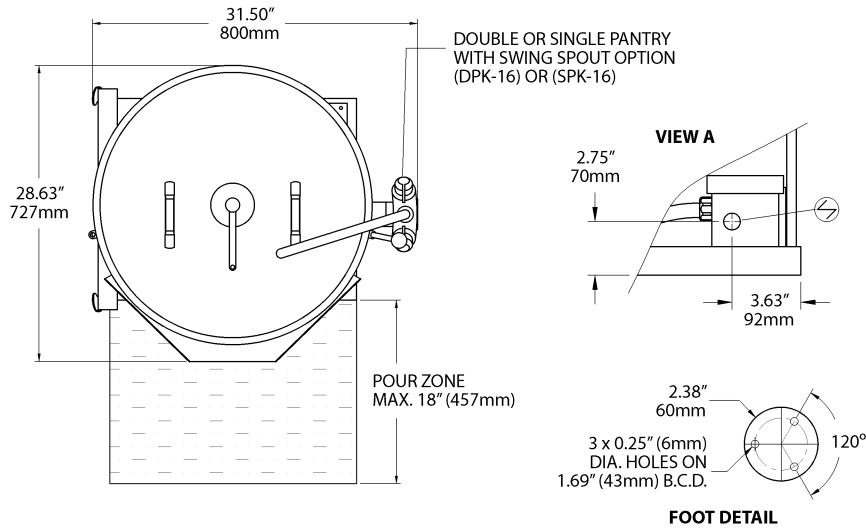

SPECIFICATIONS:

⚡ ELECTRICAL SUPPLY:												
SET-15 15 GAL (56 L)	208 V			240 V			220/380 V			240/416 V		
	KW	AMPS 1PH	AMPS 3PH	KW	AMPS 1PH	AMPS 3PH	KW	AMPS 1PH	AMPS 3PH	KW	AMPS 1PH	AMPS 3PH
	7.4	35.4	20.5	7.8	32.7	18.9	6.5	N/A	10	7.8	N/A	11

DUAL VOLTAGE OF 220/380 V SHOWN ON CHART REQUIRE A 4 WIRE, 3 PH ELECTRICAL SUPPLY

APPROVALS			CLEARANCE:		(H) HOT WATER: (C) COLD WATER: PIPING: 1/2" NPT (DOUBLE) PIPING: 3/8" COPPER TUBE (SINGLE) ⚡ ELECTRIC POWER CONNECTION
UL	CSA	NSF	RIGHT: 4" (102mm)	LEFT: 4" (102mm)	
✓	✓	✓	REAR: 0.5" (13mm)		

NOTES:

Cleveland Range reserves right of design improvement or modification, as warranted.
 Many regional, state and local codes exist and it is the responsibility of the owner and installer to comply with the codes.
 Cleveland Range equipment is built to comply with applicable standards for manufacturers. Included among those approval agencies are U.L., NSF, CGA, CSA, ETL and others.

(NOT TO SCALE)
 SECT. XII PAGE 4
 0609
 Litho in U.S.A.

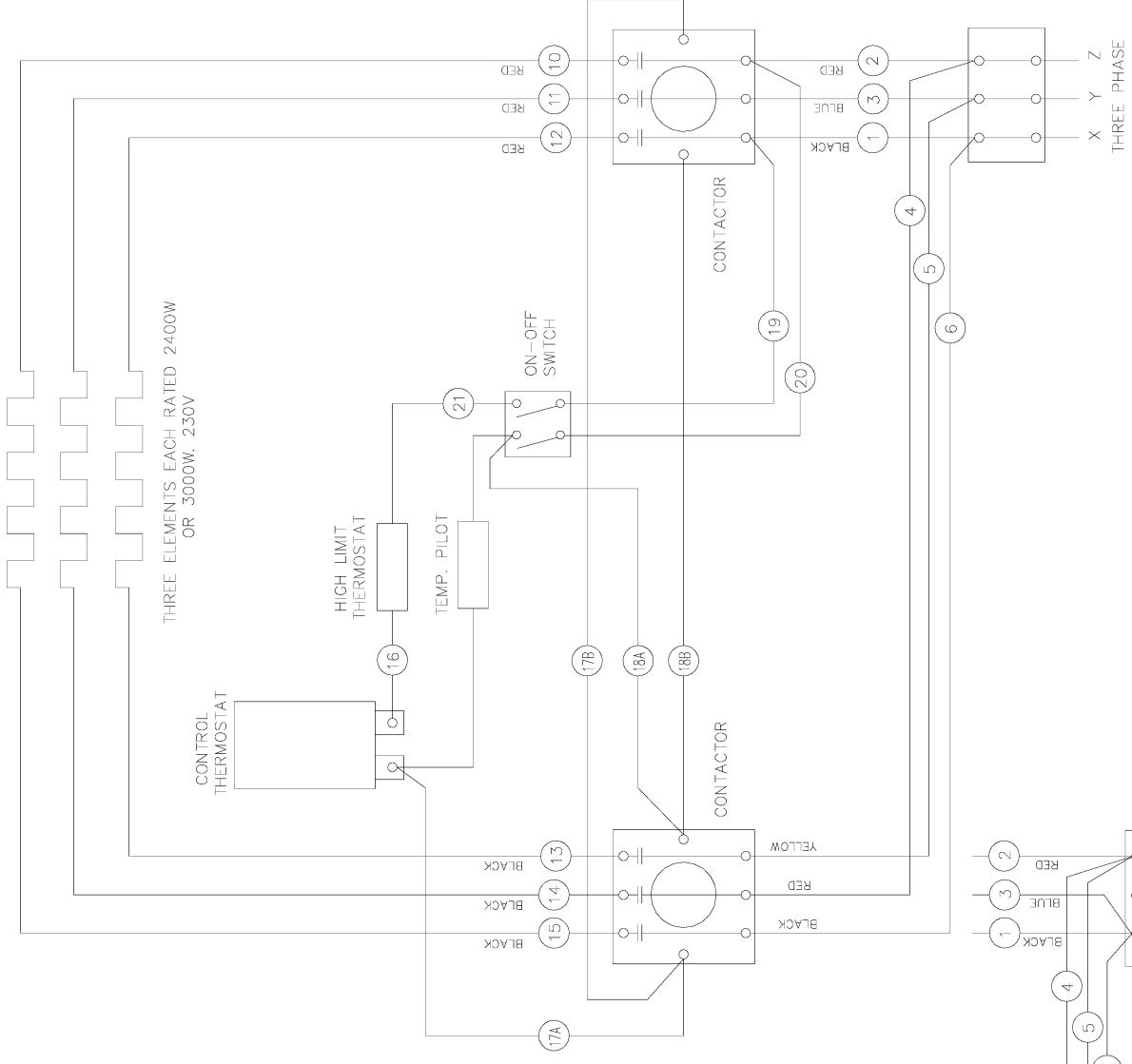

THREE ELEMENTS EACH RATED 2400W
OR 3000W, 230V

CONTROL
THERMOSTAT

HIGH LIMIT
THERMOSTAT

TEMP. PILOT

ON-OFF
SWITCH

CONTACTOR

CONTACTOR

SINGLE OR THREE PHASE
208, 220 OR 240V

MODEL: SET-10/15 FOR ELECTRICAL RATING SEE RATING PLATE

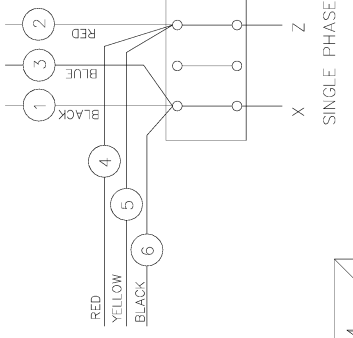

DWG: 2242101

DuraPan™ SERIES

*ELECTRIC, OPEN OR MODULAR BASE,
30 & 40 GALLON (115 & 150 LITER)*

MODELS: SEL-30-TR SEM-30-TR
 SEL-40-TR SEM-40-TR

Cleveland Standard Features

- Leg or Modular Base
- Full 30/40 Gallon (115/150 Liters) Capacity Rating to Bottom of Pouring Lip
- Power Tilt (Hydraulic Hand Tilt Optional)
- Stainless Steel Clad 5/8" Cooking Surface Guaranteed against warpage
- Stainless Steel Coved Cornered Pans with both Gallon and Liter Markings
- Space-Saving Design- No Clearance Required at rear or sides (optional Faucet and Console requires 4 1/2" on one side)
- All Stainless Steel Construction for durability and easy cleaning
- Adjustable, Electronic Thermostat controls temperature from 100°F to 425°F
- High Efficiency Heating System with even heat distribution - 14 kW's for 30 gallon models, 18 kW's for 40 gallon models.
- Fast Heat-Up and Recovery Time-Preheats in 15 minutes, full capacity from cold to boiling in 60 minutes
- Spring Assist Cover with Adjustable Vent and Full Width Handle
- On/Off Switch, Thermostat Knob and Pilots, recessed to avoid breakage
- Four Stainless Steel, Level adjustable feet, rear flanged for bolting
- Serviceable from the front of the unit
- Two Pilot Lights; Green = Power on, Amber = Temperature Cycling
- Splash Proof Controls and Water Tight Electrical Connections
- High Limit Safety Device set at 450°F (232°C)
- Anti-Splash Pouring Lip
- Typical approvals include UL, CSA, CE and NSF

Options & Accessories

- Sliding Drain Drawer with Splash Screen (SLD) (for SEL models only)
- Hydraulic Hand Tilt with quick lowering feature (HTS)
- Power Tilt with Hand Tilt Override (PT1)
- Double or Single Pantry Faucet (SPS14, DPS14), includes Faucet Mounting Bracket
- Double or Single Pantry Skillet Filler with 60" hose (SKF-S or DKF-S)



Open base model shown with optional Drain Drawer (SLD) and Power Tilt (PT1)

Short Form Specifications

Shall be CLEVELAND, Tilting Skillet; Model SE - ____ - TR ____ KW, ____ Volts holding no less than ____ gallons (____ liters); Complete with thermostatic and Safety Controls; Gallon Markings; Stainless Steel Clad; 5/8" Cooking Surface; Power Tilt; Spring Assist Cover with adjustable Vent. All Stainless Steel Construction. No Clearances Required.

- Hot & Cold Water Pre-Rinse Spray Head with Hose (PRS-S)
- Voltage Options:
 - VOSK1, 240 Volt, 60 Hz, 3 Phase
 - VOSK2, 380/415 Volt, 50 Hz, 3 Phase - for export
 - VOSK3, 440/480 Volt, 60 Hz, 3 Phase
- Food Strainers for pouring spout (FS)
- Vegetable Steamers (VS)
- Poaching Pans (PP)
- Wall Mounting (WMS)
- In-Wall Carriers (IWCS)
- Pan Carriers (PCS), not available on 30 gallon models with a Tangent Draw-Off Valve
- 2" Tangent Draw-Off Valve (TD2), left side only

DIMENSIONS

MODEL	A	B	C	D	E	F
SEL-30-TR	36"	32"	9"	5"	20"	3"
	(915mm)	(812mm)	(229mm)	(127mm)	(508mm)	(76mm)
SEL-40-TR	48"	44"	12 1/8"	8"	22"	6"
	(1220mm)	(1118mm)	(308mm)	(203mm)	(559mm)	(153mm)

CAPACITIES

In 4 oz. servings. Other sizes may be calculated.
 30 gallons / 115 Liters 960
 40 gallons / 150 Liters 1280

SPECIFICATIONS

CLEARANCE	APPROX. SHIPPING WEIGHTS
RIGHT: 1" (26mm) (4 1/2"/115mm with Faucet)	SEL-30-TR 420 LBS. 191 KG.
LEFT: 1" (26mm)	
REAR: 1" (26mm)	SEL-40-TR 490 LBS. 223 KG.

ELECTRICAL

SEL-30-TR & SEM-30-TR (Standard Wattage)						
Volts	Ph	Hz	Total Watts	Amps	Wire Size	
208	1	60	14400	69.2	4	
208	3	60	14400	40	8	
240	1	60	14400	60	6	
240	3	60	14400	34.6	8	
380	1	50	14400	37.9	8	
380	3	50	14400	21.9	10	
416	1	50	14400	34.6	8	
416	3	50	14400	20	10	
480	1	60	14400	30	8	
480	3	60	14400	17.3	10	

SEL-40-TR & SEM-40-TR (Standard Wattage)						
Volts	Ph	Hz	Total Watts	Amps	Wire Size	
208	1	60	18000	86.5	3	
208	3	60	18000	50	6	
240	1	60	18000	75	4	
240	3	60	18000	43.4	8	
380	1	50	18000	47.3	6	
380	3	50	18000	27.3	10	
416	1	50	18000	43.3	6	
416	3	50	18000	25	10	
480	1	60	18000	37.5	6	
480	3	60	18000	21.7	10	

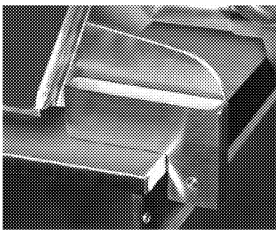

EXTERIOR HINGES (REQUIRED FOR OPTIONAL TD 2)

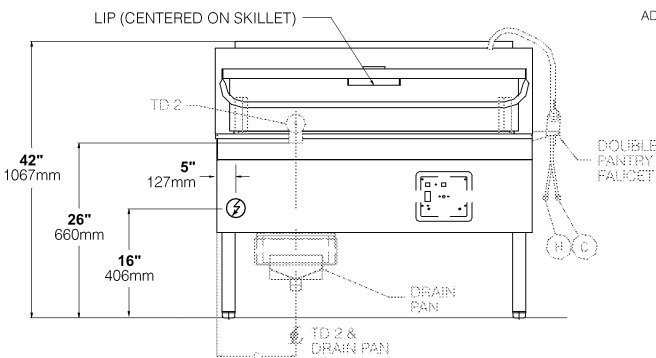
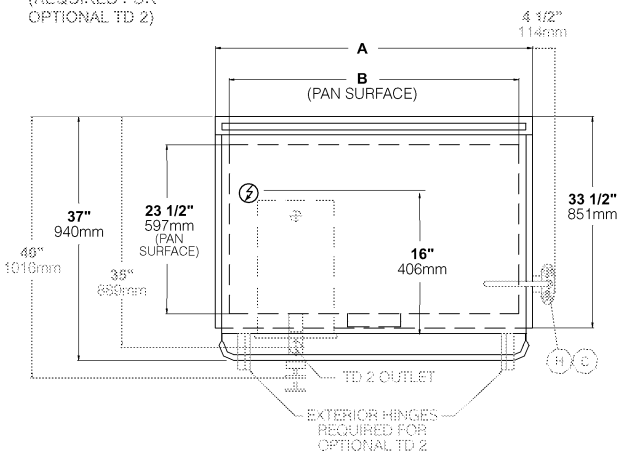
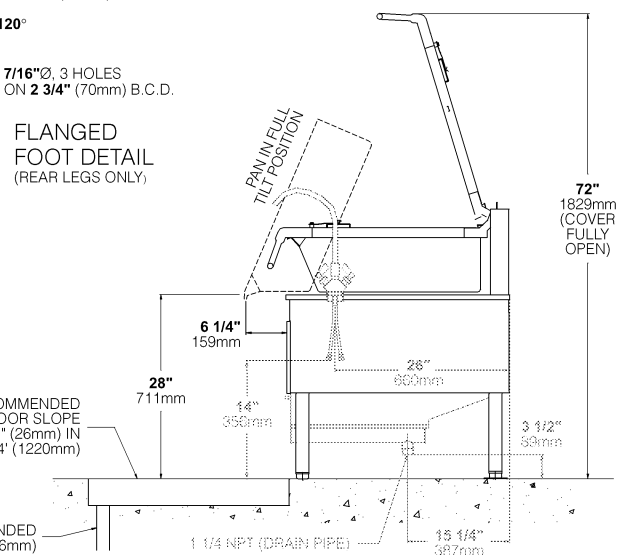
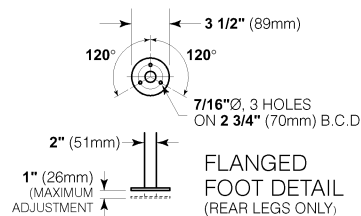
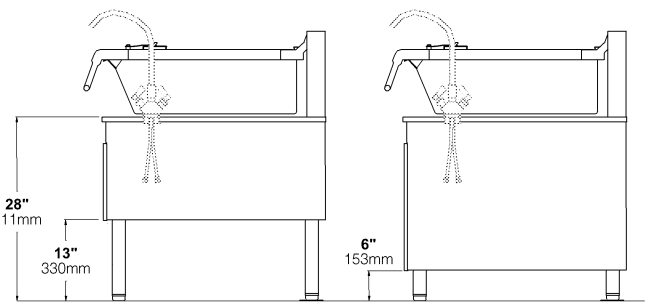
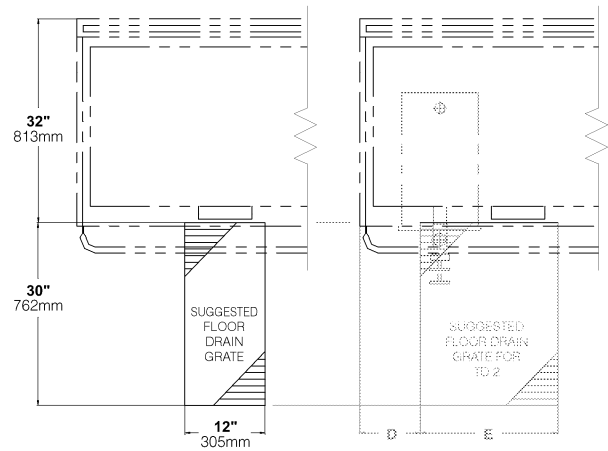

NOTE: NON STANDARD ITEMS ARE SHOWN IN GRAY

NOTES:

Cleveland Range reserves right of design improvement or modification, as warranted.
 Many regional, state and local codes exist and it is the responsibility of the owner and installer to comply with the codes.
 Cleveland Range equipment is built to comply with applicable standards for manufacturers. Included among those approval agencies are U.L., NSF, CGA, CSA, ETL and others.

(NOT TO SCALE)

SECT. **XII** PAGE **6**

0609

Litho in U.S.A.

CLEVELAND RANGE SEL-R SEQUENCE OF OPERATIONS

When using these instructions refer to the SEL-R wiring schematic.

1. Supply Voltage is sent to the normally open contacts of the element contactor
2. Supply Voltage is sent through the 1.5 amp fuse to the power switch
3. With the power switch in the on position, supply voltage is sent to the primary of the main transformer.
4. 120 VAC is sent from pins 1 and 2 on the secondary of the main transformer through the 1 amp fuse to the tilt interrupter switch.
 - If the skillet is in the down position 115 VAC is sent from the interrupter switch through the high limit to pin 9 on the thermostat.
5. When the thermostat is calling for heat 115 VAC is sent to the coil of the element contactor.
 - The normally open contacts of the element contactor close sending supply voltage to the elements.
 - The elements will heat the skillet until the thermostat is satisfied.
6. When the thermostat is satisfied 115VAC is removed from pin 10 and the heat circuit is de-energized.
7. If the skillet is equipped with the optional Power Tilt, 24 VAC is sent from terminals 3 and 4 of the secondary of the main transformer through the 15-amp fuse to the bridge rectifier
8. The AC current is rectified to DC voltage that is then filtered by the capacitor and resistor and sent to the tilt switch.
9. When the switch is in the up position the DC motor is energized and the actuator extends.
10. When the switch is in the down position the polarity is reversed and the motor is energized to retract the actuator.

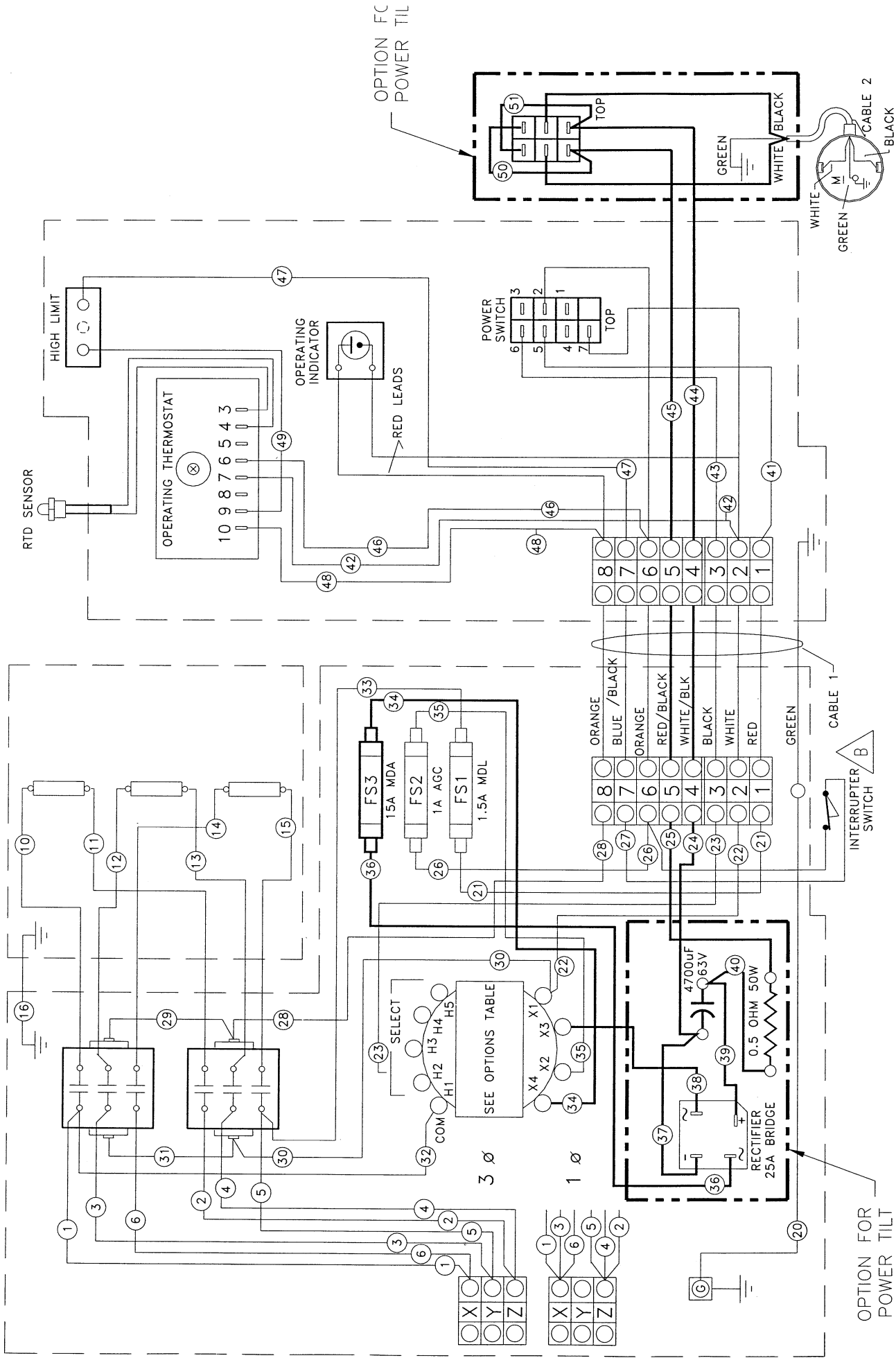

MODEL F30,40E-L,MR, SEL30,40TR 208/240/380/415/480V DELTA

SK90123-4

(208/240/380/415/480V 1Ø/3Ø)

OPTION FOR POWER TILT

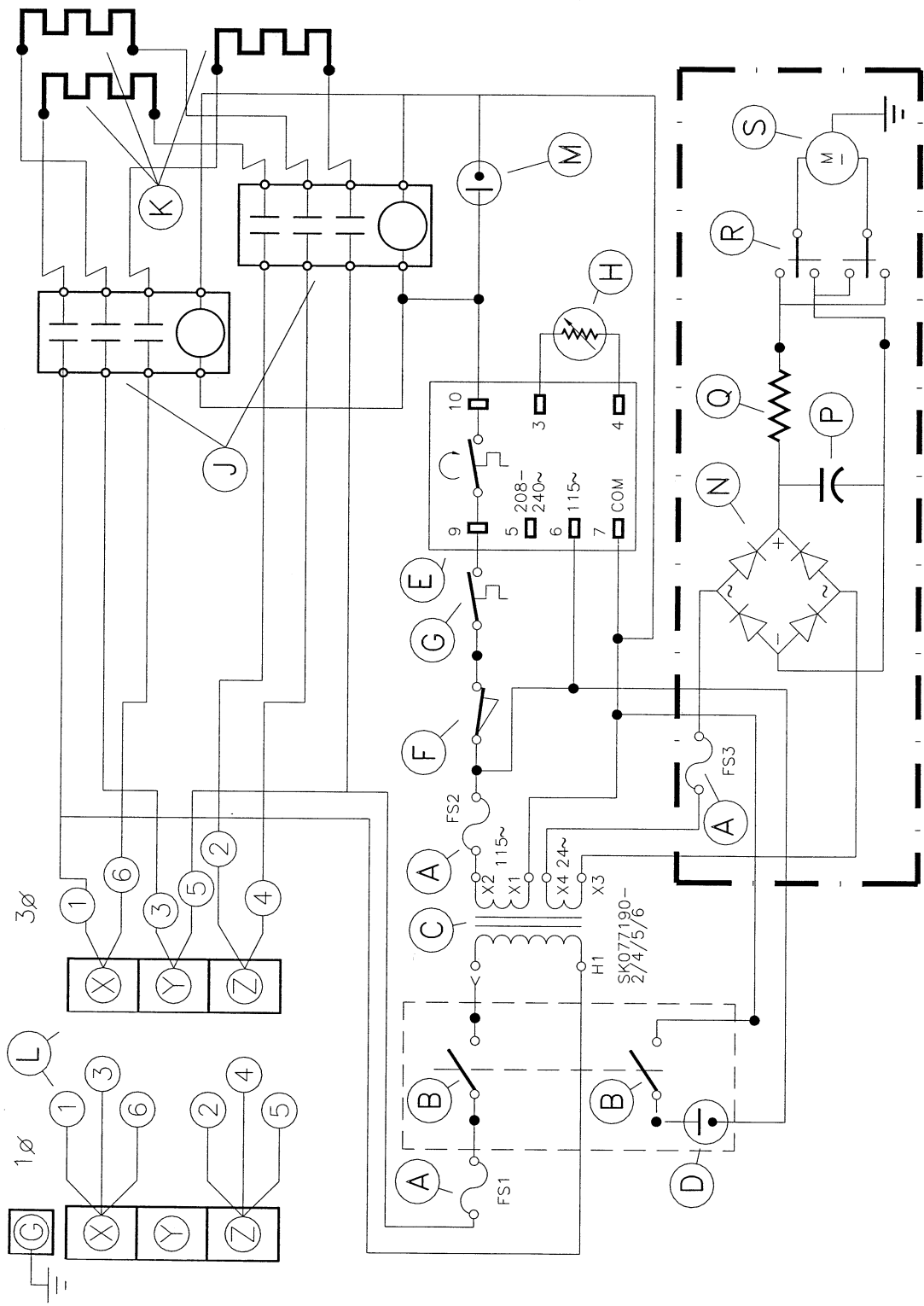

- A— FUSE
- B— POWER SWITCH
- C— TRANSFORMER
- D— PILOT—RED
- E— ELECTRONIC THERMOSTAT
- F— INTERRUPTER SWITCH
- G— HIGH LIMIT SWITCH
- H— RTD SENSOR
- J— CONTACTOR
- K— ELEMENT
- L— TERMINAL BLOCK
- M— PILOT—YELLOW
- N— RECTIFIER
- P— CAPACITOR
- Q— RESISTOR
- R— TILT CONTROL
- S— ACTUATOR
- — — — — POWER TILT ONLY

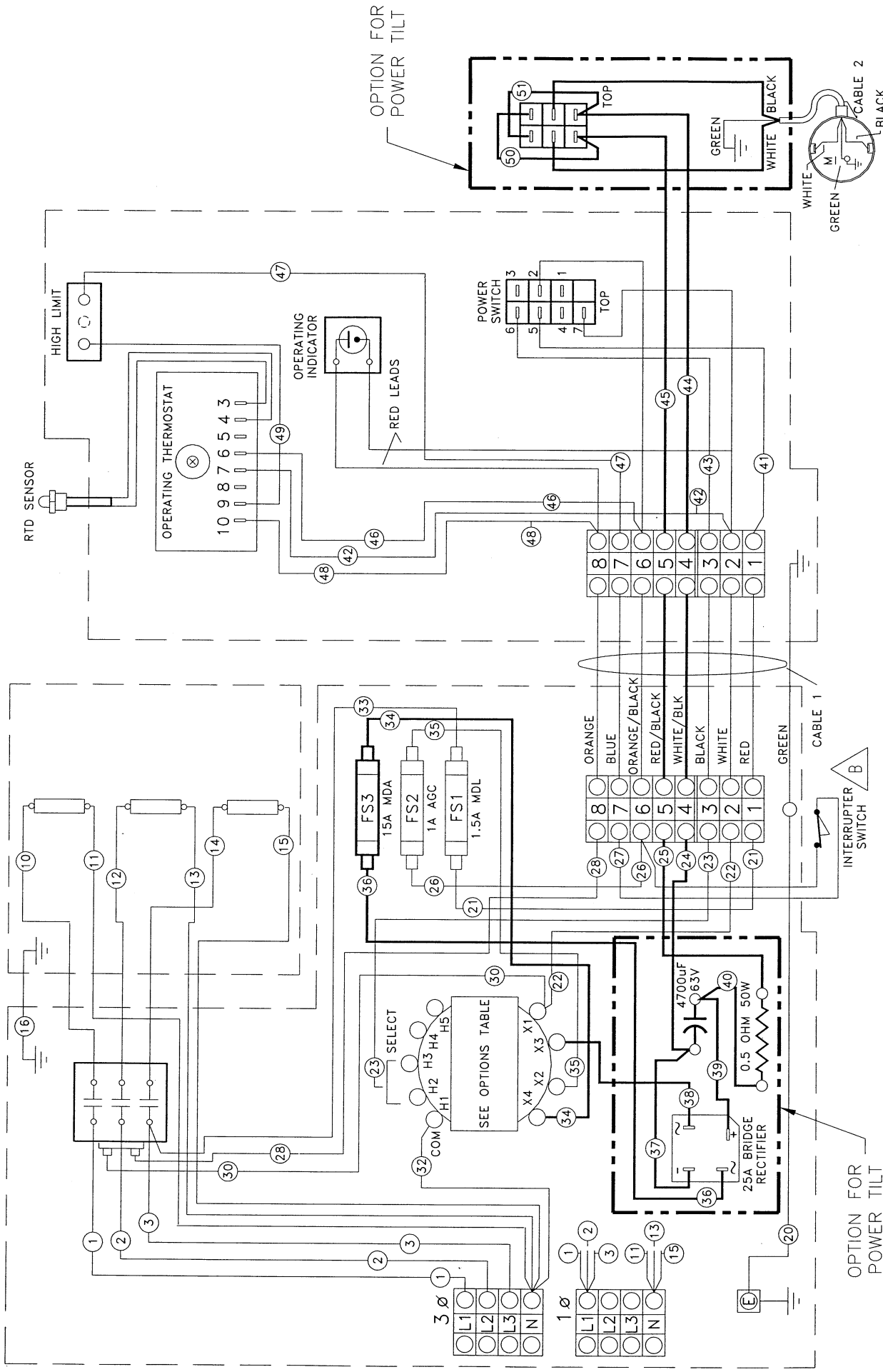

MODEL F30,40E-L,MR, SEL30,40TR 220/240V 3N~

SK90123-3
 (220/380, 240/415 1, /3N~)
 OPTIONS TABLE

OPTION FOR
POWER TILT

OPTION FOR
POWER TILT

**PROBLEM:
SEL-R
Skillet won't
Heat**

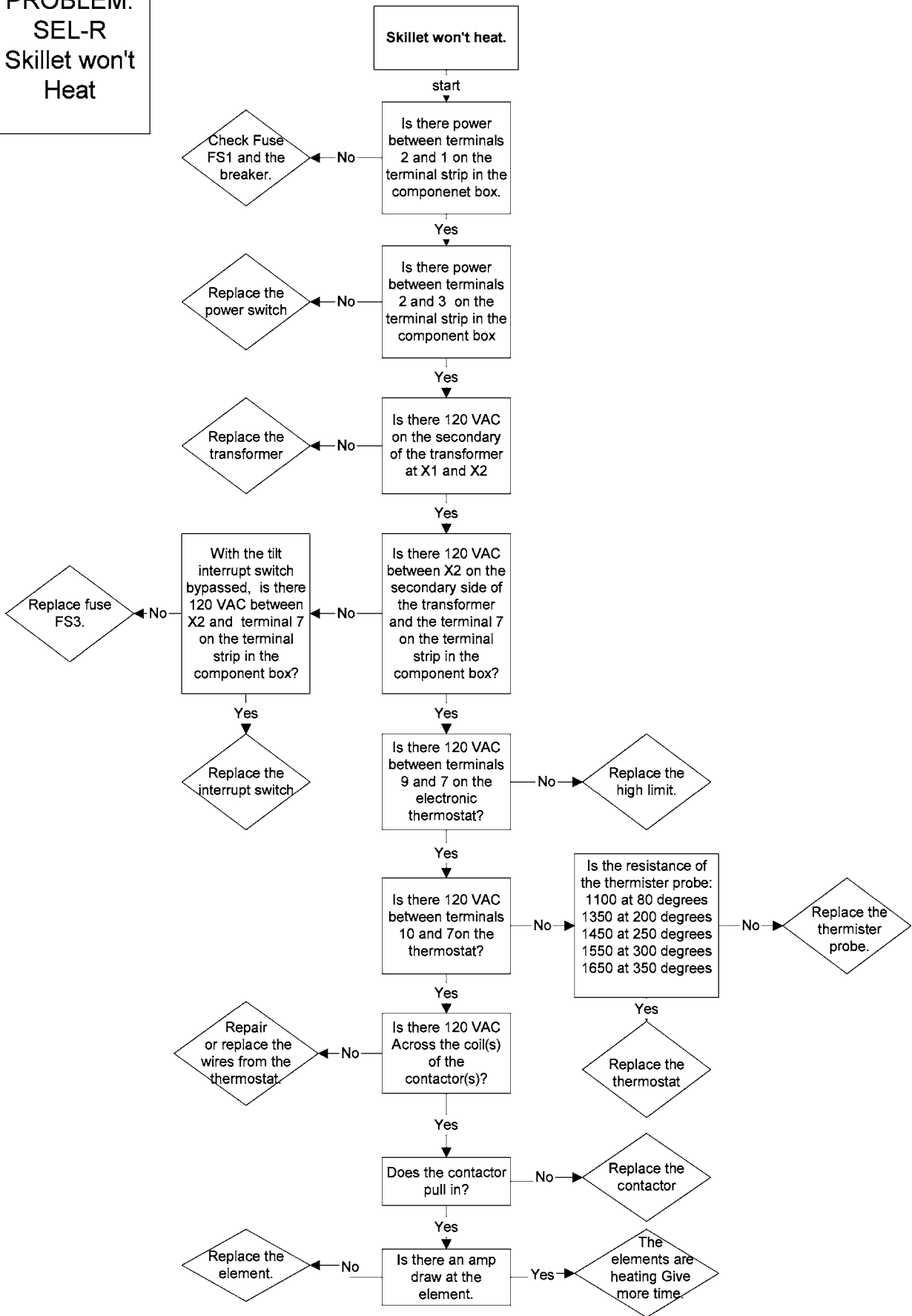

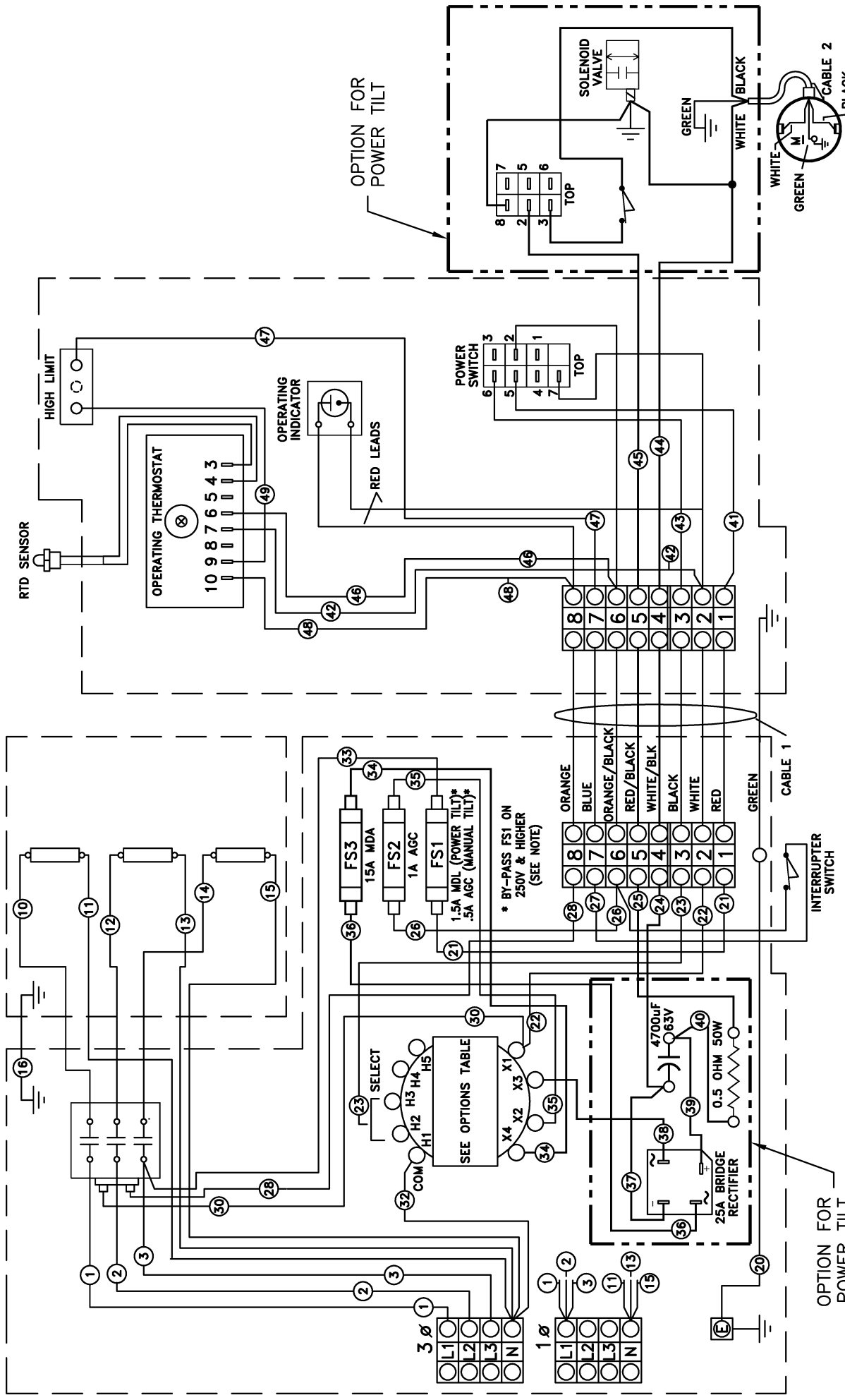

MODEL F30,40E-L,MR, SEL30,40TR 220/240V 3N~
 SK90123-3 REV. E
 (220/380, 240/415 1N~/3N~)

NOTE: ON 250 VOLTS & HIGHER,
 JOIN WIRES # 21 & 33 TOGETHER

OPTIONS TABLE

TILT/220V/240V	PT	H3
KE53838-31	PT	H3
KE53838-30	PT	H2
KE53838-33	HT	H2
KE53838-15	HT	H2

HT= HAND TILT
 PT= POWER TILT

PowerPan™ SERIES

*ELECTRIC, 35" RIM HEIGHT,
30 & 40 GALLON (110 & 150 LITER)*

MODELS: SEL-30-T1
 SEL-40-T1

Cleveland Standard Features

- Available in 30 & 40 gallon (115 & 150 liter) open frame design models. Full capacity to bottom of pouring lip.
- High efficiency heating system with even heat distribution. 30 gallon models (115 liter) feature a 12 KW heating element and the 40 gallon models (150 liter) feature a 18 KW heating element.
- Open base design for easy cleaning and maintenance.
- 5/8" Stainless Steel Bead Blasted cooking surface prevents warping and keeps food from sticking.
- Durable 12 gauge, 304 Stainless Steel pan construction. 5/8" (16mm) mild steel clad bottom plus a 1/16" (1.6mm) Stainless Steel plate for even temperature distribution.
- Low 35" rim height for easy operation and cleaning.
- Splash Proof Controls and construction.
- Easy-to-turn manual hand tilt with enclosed permanently lubricated gearbox. Optional power tilt with manual override available.
- Gallon/Liter Markings and Vented Spring Assist Cover standard.
- Available with Optional 2" Tangent Draw-Off Valve.
- 10° Cooking Feature. Tilt unit up to 10° without the power being turned off.
- Adjustable, Electronic Thermostat accurately controls temperature from 100° to 450° F.
- Standard Voltages 208-240, single and three phase.
- Spring-Assist Cover with full width handle and vent.
- Typical approvals include UL, CSA, CE and NSF.

Options & Accessories

- Power Tilt with Manual Override (PT2)
- 2" (50 mm) Tangent Draw-Off Valve (TD2SK), left side only
- Double or Single Pantry Faucet (SPS14, DPS14), includes Faucet Mounting Bracket
- Faucet Bracket (FBKT1)
- Pan Carriers (PCS), not available on 30 gallon models with a Tangent Draw-Off Valve
- Vegetable Steamer Baskets (VS)
- Hot & Cold Water Pre-Rinse Spray Head with Hose (PRS-S)
- Poaching Pans (PP)



Shown with optional 2" Tangent Draw Off Valve

Short Form Specifications

Shall be CLEVELAND, Tilting Skillet Model Number SEL-____-T1, electric (____ KW, ____ Volts) holding no less than ____gallons (____ liters); Complete with Thermostatic and Safety Controls, Gallon/Liter Markings, 5/8" Stainless Steel Clad Cooking Surface with Bead Blasted Finish, Easy to use Manual Hand Tilt with Enclosed Permanently Lubricated Gearbox, Spring Assist Cover with adjustable Vent, Adjustable Feet with Rear Flanged and Front Bullet Style, Gallon/Liter Markings and Splash Proof Controls

- Protective Control Cover (CP-PCB-T1)
- Casters, 2 swivel, 2 locking (CST1)
- High Wattage Option (HW) (required for CE)
16KW on 30 gallons, 24KW on 40 gallons
- Voltage Options:
 - VOSK1, 240 Volt, 60 Hz, 3 Phase
 - VOSK2, 380/415 Volt, 50 Hz, 3 Phase - for export
 - VOSK3, 440/480 Volt, 60 Hz, 3 Phase

DIMENSIONS

MODEL	A	B	C	D	F	G	⌀	CLEARANCE
SEL-30-T1	37 7/8"	24 1/2"	31 3/4"	12"	18 1/4"	5 3/4"	3"	RIGHT: 4" (102mm) (manual tilt) 1" (26mm) (power tilt)
	(963mm)	(623mm)	(807mm)	(305mm)	(464mm)	(146mm)	(204mm)	
SEL-40-T1	49 7/8"	36 1/2"	43 3/4"	18"	24 1/4"	5 3/4"	3"	LEFT: 0', REAR: 0'
	(1267mm)	(928mm)	(1112mm)	(458mm)	(616mm)	(146mm)	(204mm)	

ELECTRICAL

Volts	Ph	Hz	Total Watts	Amps	Wire Size	Volts	Ph	Hz	Total Watts	Amps	Wire Size
SEL-30-T1 (Standard Wattage)						SEL-40-T1 (Standard Wattage)					
208	1	60	12000	57.7	4	208	1	60	18000	86.5	2
208	3	60	12000	33.3	8	208	3	60	18000	50.0	6
240	1	60	12000	50.0	6	240	1	60	18000	75.0	3
240	3	60	12000	28.9	8	240	3	60	18000	43.3	6
380	1	50	10013	26.3	8	380	1	50	15019	39.5	6
380	3	50	10013	15.2	12	380	3	50	15019	22.8	10
416	1	50	12000	28.8	8	416	1	50	18000	43.3	6
416	3	50	12000	16.7	10	416	3	50	18000	25.0	8
480	1	60	12000	25.0	8	480	1	60	18000	37.5	6
480	3	60	12000	14.4	12	480	3	60	18000	21.7	10
SEL-30-T1 (High Wattage)						SEL-40-T1 (High Wattage)					
208	1	60	16020	77.0	3	208	3	60	24000	66.6	4
208	3	60	16020	44.5	6	240	3	60	24000	57.7	4
240	1	60	16020	66.8	4	380	3	50	20026	30.4	8
240	3	60	16020	38.5	6	416	3	50	24000	33.3	8
380	1	50	13367	35.2	8	480	3	60	24000	28.9	8
380	3	50	13367	20.3	10						
416	1	50	16020	38.5	6						
416	3	50	16020	22.2	10						
480	1	60	16020	33.4	8						
480	3	60	16020	19.3	10						

CAPACITIES

In 4 oz. servings. Other sizes may be calculated.
 30 gallons / 115 Liters.....960
 40 gallons / 150 Liters.....1280

APPROXIMATE SHIPPING WEIGHTS
SEL-30-T1 390 LBS. (178 KG.)
SEL-40-T1 410 LBS. (187 KG.)

LEG LOCATION & SUGGESTED FLOOR DRAIN DETAIL

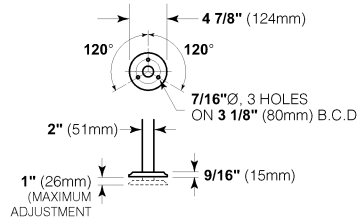
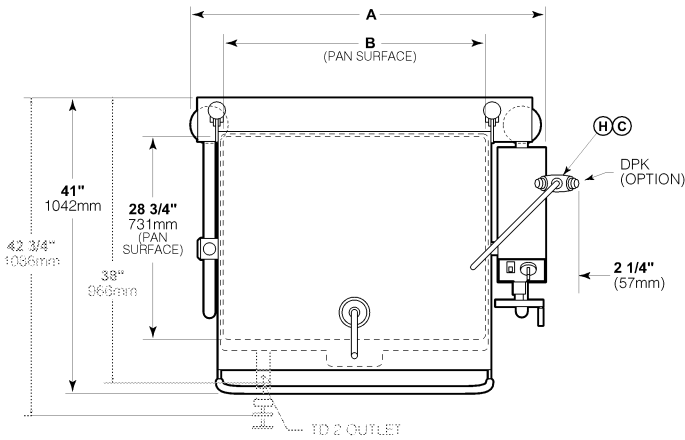
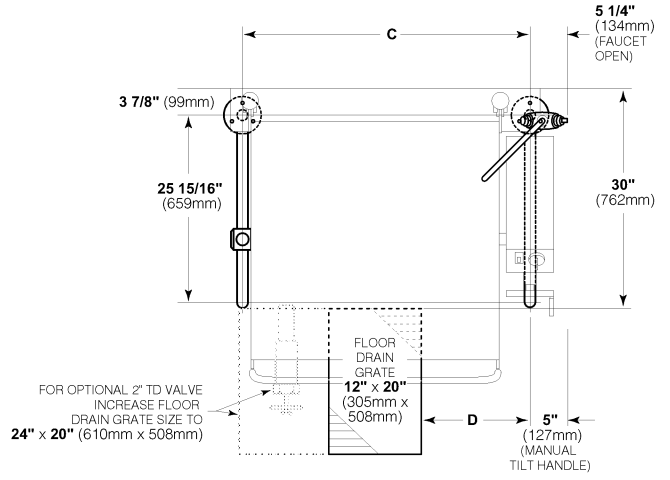

FLANGED FOOT DETAIL (REAR LEGS ONLY)

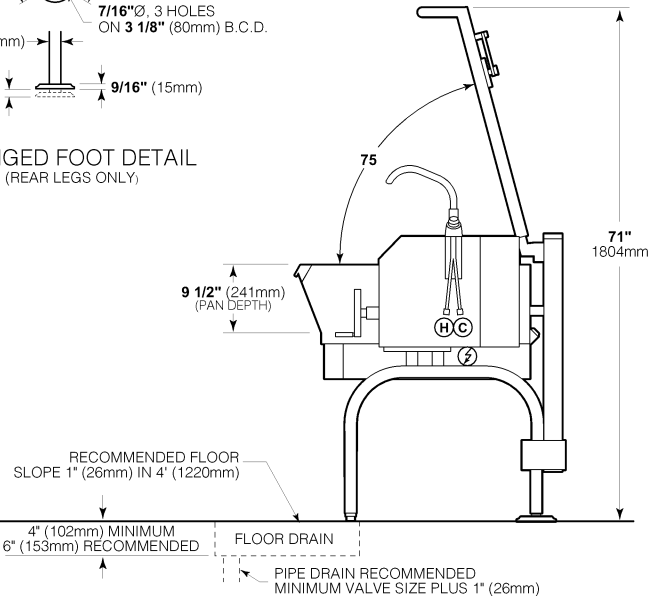
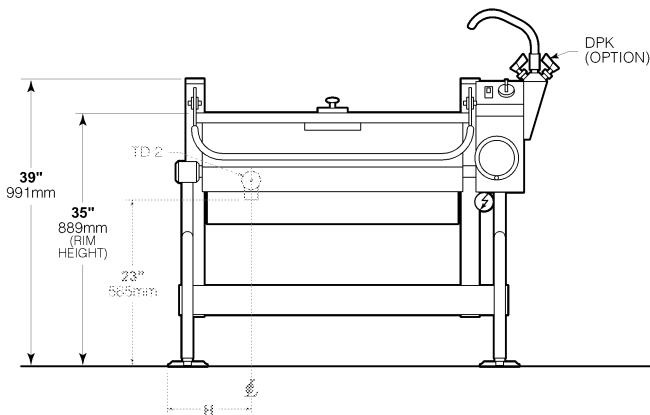

NOTE: OPTIONAL 2" TD VALVE SHOWN IN GRAY

NOTES:

Cleveland Range reserves right of design improvement or modification, as warranted. Many regional, state and local codes exist and it is the responsibility of the owner and installer to comply with the codes. Cleveland Range equipment is built to comply with applicable standards for manufacturers. Included among those approval agencies are U.L., NSF, CGA, CSA, ETL and others.

(NOT TO SCALE)

SECT. **XII** PAGE **10**

0609

Litho in U.S.A.

CLEVELAND RANGE SEL T1 SEQUENCE OF OPERATIONS

When using these instructions refer to the SEL-T1 wiring schematic.

1. Supply Voltage is sent to the primary of the 120 VAC transformer.
2. Supply voltage is sent to the normally open contacts of the Heat Contactors, C1 and C2.
3. 120 VAC is sent from the secondary of the 120VAC transformer through the 3 amp fuse to
 - The primary of the 24 VAC transformer
 - 24 VAC is sent from the secondary of the 24VAC transformer through the 1.25 amp fuse to the on/off switch.
 - Contacts of the R1 Heat Relay
4. 120 VAC is sent from the secondary of the 120 VAC transformer to the optional Power Tilt Circuit (See step 9).
5. With the On/Off switch in the On position.
 - 24 VAC is sent through the normally closed high limit switch to the mercury switch..
 - If the skillet is in the down position then 24 VAC is sent through mercury switch to pin 9 on the thermostat.
6. If the skillet is calling for heat the 24 VAC is sent from pin number 10 to R1 Heat Relay.
 - The normally open contacts of the Heat relay close sending 120 VAC to the Heat contactor coils C1 and C2.
7. The Contactor close and supply Voltage is sent to the elements.
 - The elements heat until the thermostat is satisfied.
8. When thermostat is satisfied, 24 VAC is removed from pin 10 on the thermostat and the heat circuit is de-energized.
9. If the skillet has the optional Power Tilt option and is in the down position, 120 VAC is sent from the secondary of the 120 VAC transformer through the circuit breaker and the up limit switch to the tilt switch.
10. With the tilt switch in switch in the Up position
 - 120 VAC is sent to the Bridge Rectifier
 - 115 VDC is sent from the rectifier through the 30-ohm resistor to the normally open RY10 and RY11 relay contacts.
 - 120 VAC is sent to the RY10 relay coil.
 - The normally open RY10 contact close and 90 VDC is sent to the DC motor

- The DC motor is energized and the skillet tilts until the switch is released or the up limit switch opens.

11. With the Tilt switch in the Down position

- 120 VAC is sent to the Bridge Rectifier
 - 115 DC is sent from the rectifier through the 30-ohm resistor to the normally open RY10 and RY11 relay contacts.
- 120 VAC is sent to the RY11 relay coil.
- The normally open RY11 contact close and the polarity of the 90 VDC is reversed.
- The DC motor is energized and the skillet lowers until the switch is released or the Down limit switch opens.

**PROBLEM:
SEL-T1
Skillet won't
Heat**

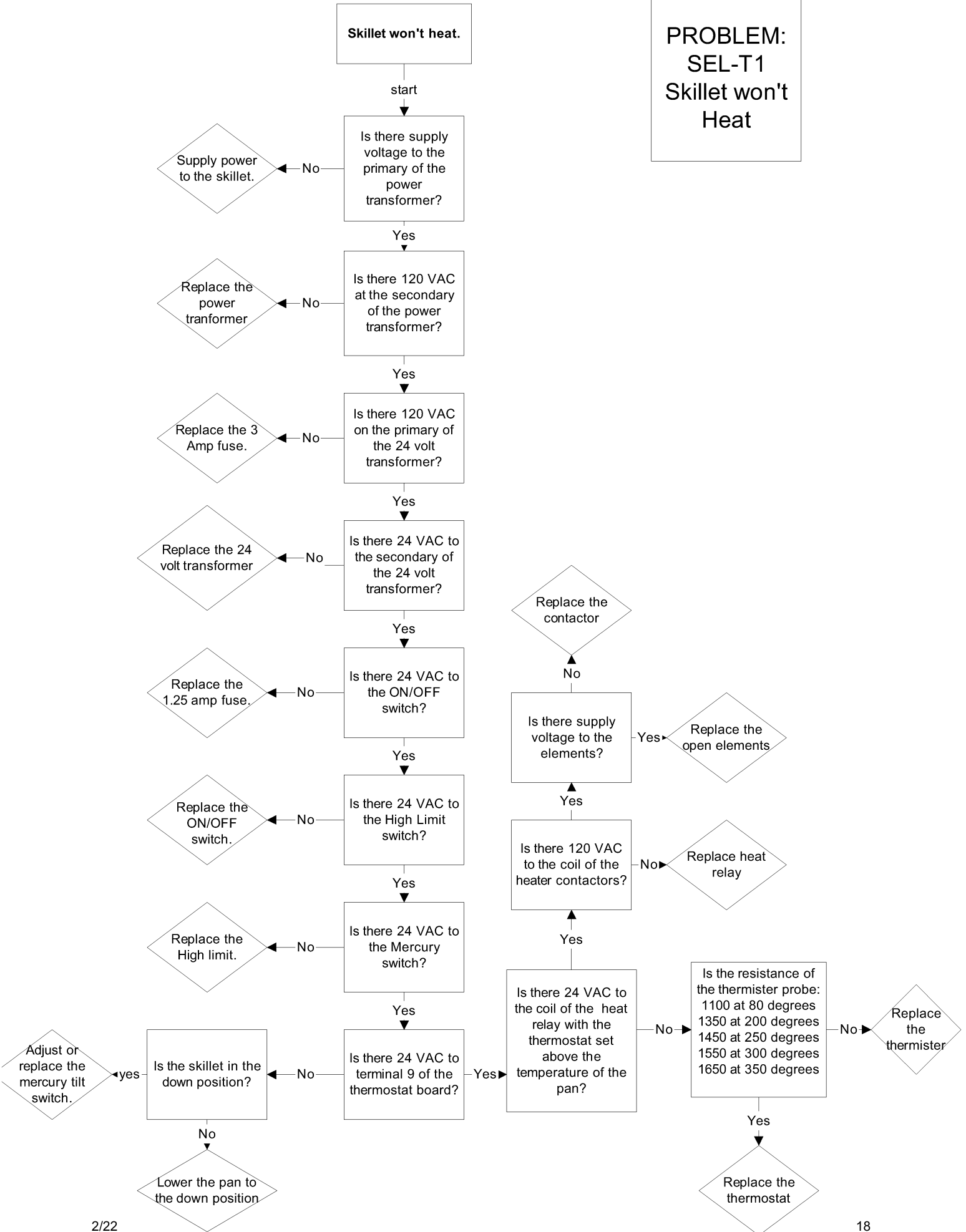

WIRING DIAGRAM

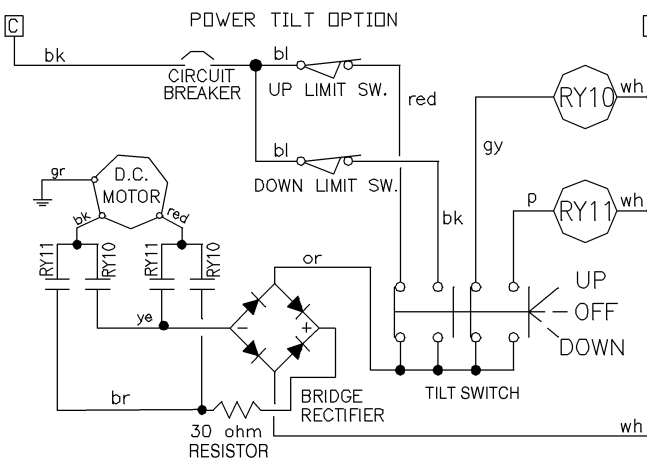
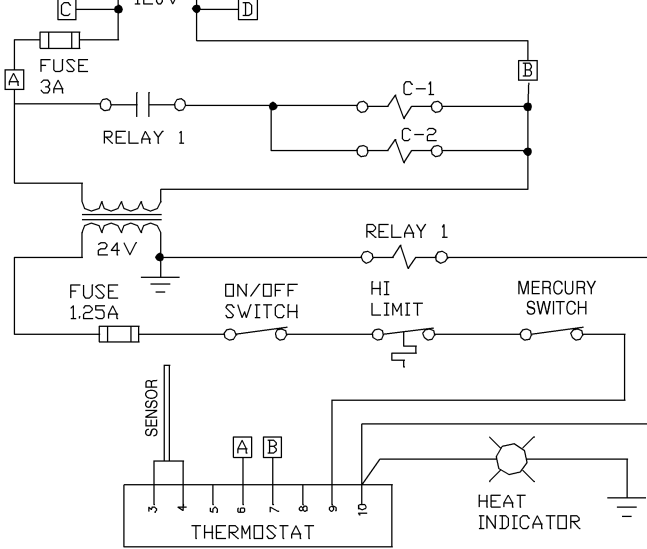
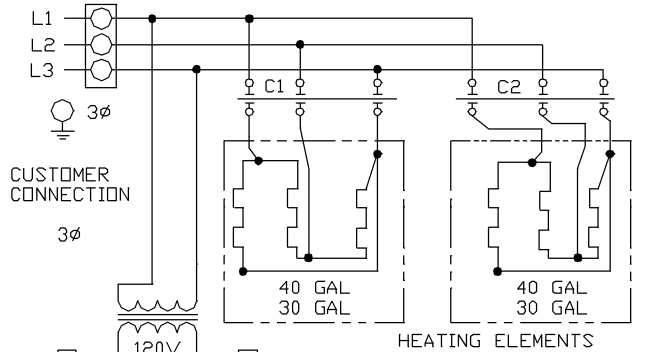
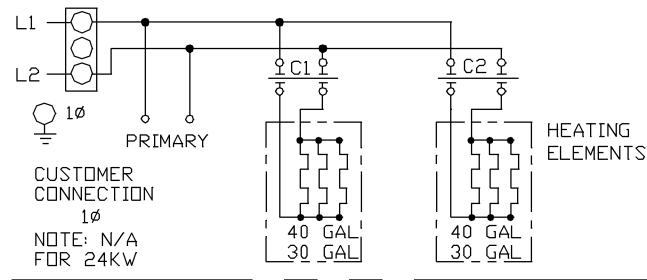

SEL-30/40-T1

SK90126-2

ELECTRICAL COMPONENT PART #s

FUSE 3A	KE52936-6	10
FUSE 1.25A	KE52936-8	10
RELAY 1	2475500	12

HEATING ELEMENTS -

SEE "PAN MOUNT ASSEMBLY" ON PAGE # 8

ON/OFF SWITCH	2474103	11
HIGH LIMIT	KE55069-7	8
THERMOSTAT	SE00119	11
SENSOR	SK50933-1	8
HEAT INDICATOR	SK50905-1	16
CIRCUIT BREAKER	KE55079-1	10
MERCURY SWITCH	KE50294-1	10
LIMIT SWITCH	KE51007	9
RY10 (RELAY)	KE50753-10	12
RY11 (RELAY)	KE50753-10	12
DC MOTOR	KE52832-4	11
BRIDGE RECTIFIER	KE50581	12
RESISTOR	SK50930	12
TILT SWITCH	KE53137-3	11
- SECTION	KE53184	11
- CONTACT BLOCK	KE53138-1	11

DuraPan™ SERIES

*GAS, OPEN OR MODULAR BASE,
30 & 40 GALLON (115 & 150 LITER)*

MODELS: SGL-30-TR SGM-30-TR
 SGL-40-TR SGM-40-TR

Cleveland Standard Features

- Leg or Modular Base
- Full 30/40 Gallon (115/150 Liters) Capacity Rating to Bottom of Pouring Lip
- Power Tilt (Hydraulic Hand Tilt Optional)
- Stainless Steel Clad 5/8" Cooking Surface Guaranteed against warping
- Stainless Steel Covered Cornered Pans with both Gallon and Liter Markings
- All Stainless Steel Construction for durability and easy cleaning
- Adjustable, Electronic Thermostat controls temperature from 100°F to 425°F
- High Efficiency Heating System with even heat distribution
- Electronic Spark Ignition (ESS)
- Fast Heat-Up and Recovery Time-Preheats in 11 minutes, full capacity from cold to boiling in 60 minutes
- Spring Assist Cover with Adjustable Vent and Full Width Handle
- On/Off Switch, Thermostat Knob and Pilots, recessed to avoid breakage
- Four Stainless Steel, Level adjustable feet, rear flanged for bolting
- All Controls are serviceable from the front of the unit
- Two pilot lights; Green = Power on, Amber = Temperature Cycling
- Splash Proof Controls and Water Tight Electrical Connections
- High Limit Safety Device set at 475°F (246°C)
- Anti-Splash Pouring Lip
- Supplied with Cord & Plug for 115-volt controls
- Typical approvals include AGA, CSA, CE and NSF

Options & Accessories

- Sliding Drain Drawer with Splash Screen (SLD) (for SGL models only)
- Hydraulic Hand Tilt with quick lowering feature (HTS)
- Power Tilt with Hand Tilt Override (PT1)
- Double or Single Pantry Faucet (SPS14, DPS14), includes Faucet Mounting Bracket
- Double or Single Pantry Skillet Filler with 60" hose (SKF-S or DKF-S)



Open base model shown with optional Drain Drawer (SLD) and Power Tilt (PT1)

Short Form Specifications

Shall be CLEVELAND, Tilting Skillet; Model SG ____ - ____ - TR gas (TYPE ____)- holding no less than ____ gallons (____ liters); complete with Thermostatic Safety and Gas Controls; Gallon Markings; Stainless Steel Clad 5/8" Cooking Surface; Power Tilt; Spring Assist Cover with adjustable Vent. All Stainless Steel Construction.

- Hot & Cold Water Pre-Rinse Spray Head with Hose (PRS-S)
- Gas types other than natural
- Voltage Option:
 - VOSK4, 220/240 Volt, 50 Hz, 1 Phase - for export
- Food Strainers for pouring spout (FS)
- Vegetable Steamers (VS)
- Poaching Pans (PP)
- Wall Mounting (WMS)
- In-Wall Carrier (IWCS)
- Pan Carriers (PCS), not available on 30 gallon models with a Tangent Draw-Off Valve
- 2" Tangent Draw-Off Valve (TD2), left side only

SECT. XII PAGE 7
0609

DIMENSIONS

MODEL	A	B	C	D	E
SGL-30-TR	36"	32"	9"	5"	20"
	(915mm)	(812mm)	(229mm)	(127mm)	(508mm)
SGL-40-TR	48"	44"	12 1/8"	8"	22"
	(1220mm)	(1118mm)	(308mm)	(203mm)	(559mm)

CAPACITIES

In 4 oz. servings. Other sizes may be calculated.
 30 gallons / 115 Liters 960
 40 gallons / 150 Liters 1280

SPECIFICATIONS

ELECTRICAL SUPPLY (6' CORD & PLUG)		GAS SUPPLY (PIPING 3/4" NPT)		CLEARANCE		APPROX. SHIPPING WEIGHTS	
VOLTS:	120	220/240	TYPE: NAT or LP	MIN. TO COMBUSTABLE SURFACES:		SGL-30-TR	
PHASE:	1	1	WATER COLUMN: 4.5 (NAT), 10.5 (LP)	SIDES: 0, REAR: 6" (153mm)		440 LBS.	
AMPS:	1.8	.83	BTU PER CU. FT.: 1000 (NAT), 2500 (LP)	MIN. TO NON COMBUSTABLE SURFACES: SIDES & REAR: 0		SGL-40-TR	
FREQ.:	60 HZ	50 HZ	SUPPLY PRESSURE:	NOTE: 4 1/2" (115mm) required on right hand side for faucet		520 LBS.	
			5" W.C. MIN (NAT), 11" W.C. MIN (LP)			237 KG	
			BTU RATINGS:				
			SGL-30-TR: 91,000 per hour				
			SGL-40-TR: 130,000 per hour				

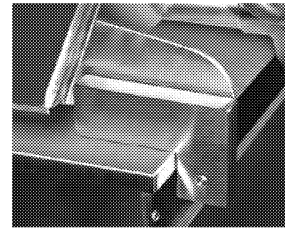

EXTERIOR HINGES
(REQUIRED FOR
OPTIONAL TD 2)

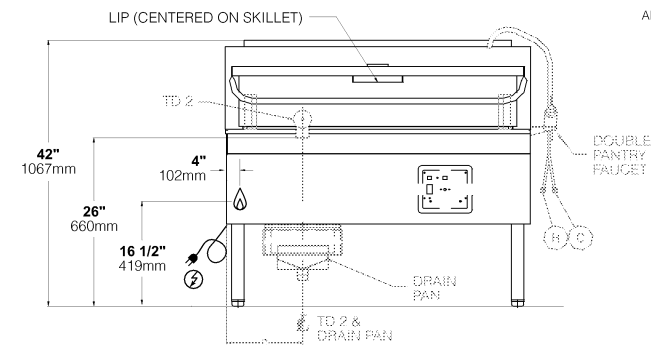
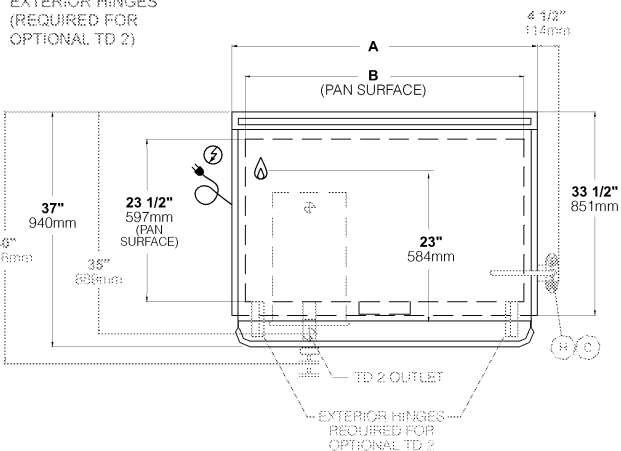

NOTE: NON STANDARD ITEMS ARE SHOWN IN GRAY

NOTES:

Cleveland Range reserves right of design improvement or modification, as warranted.
 Many regional, state and local codes exist and it is the responsibility of the owner and installer to comply with the codes.
 Cleveland Range equipment is built to comply with applicable standards for manufacturers. Included among those approval agencies are U.L., NSF, CGA, CSA, ETL and others.

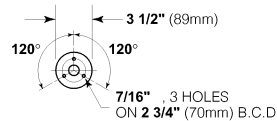
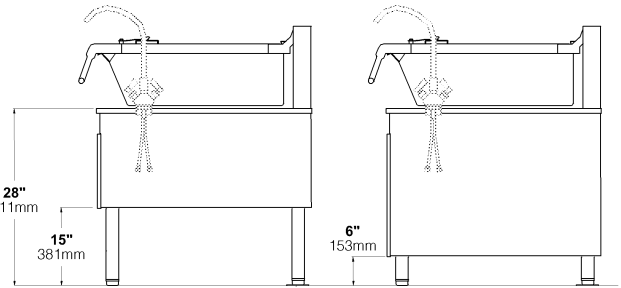
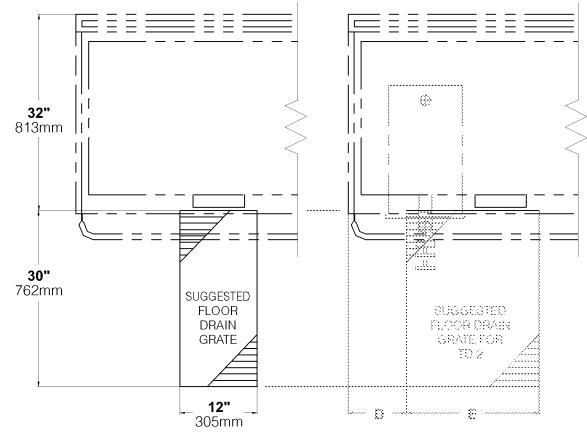

FLANGED FOOT DETAIL
(REAR LEGS ONLY)

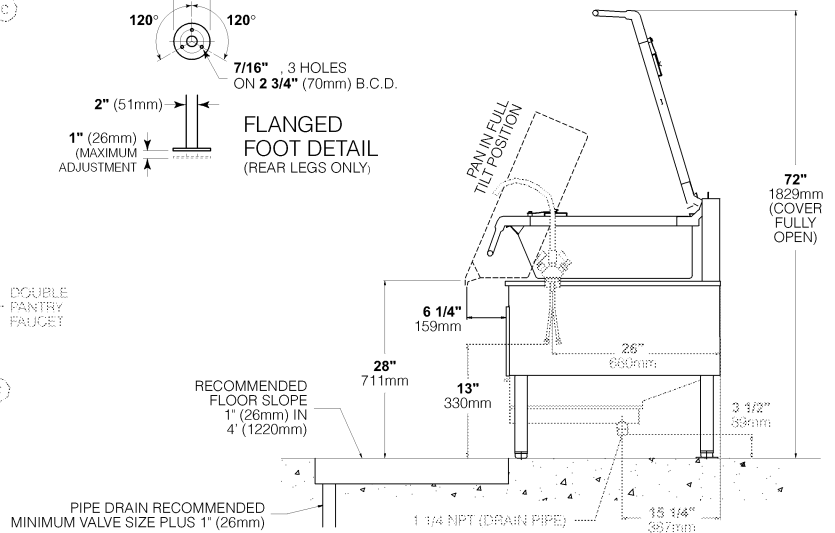

(NOT TO SCALE)

SECT. **XII** PAGE **8**
0609

Litho in U.S.A.

SGL / SGM - R

SEQUENCE OF OPERATION

* TURN POWER SWITCH ON

(INLINE FUSE TO SWITCH IS 2.5 AMP SLOW BLOW)

- A. GREEN *POWER* LIGHT IS ILLUMINATED
- B. 120 V.A.C. IS SUPPLIED TO ELECTRONIC "T" STAT
 - 1. THRU TERMINALS 6 & 7
- C. 120 V.A.C. IS SUPPLIED TO THE PRIMARY SIDE OF THE TRANSFORMER

* TRANSFORMER STEPS 120 V.A.C. DOWN TO 24 V.A.C.

- A. 24 V.A.C. PASSES THRU TO BRIDGE RECTIFIER
 - 1. INLINE FUSE IS 15 AMP SLOW BLOW
- B. RECTIFIER CHANGES 24 V.A.C. TO 24 V.D.C.
 - 1. SUPPLYING 24 V.D.C TO START CAPACITOR
- C. CAPACITOR 24 V.D.C. PASSES THRU A RESISTOR
 - 1. LIMITS VOLTAGE TO MOTOR ON HIGH CURRENT DRAW
- D. 24 V.D.C. IS NOW APPLIED TO TILT SWITCH
 - 1. PRESS SWITCH UP
 - a. MOTOR IS ENERGIZED RAISING PAN
 - 2. PRESS SWITCH DOWN
 - b. MOTOR IS ENERGIZED LOWERING PAN

** TRANSFORMER STEPS 120 V.A.C. DOWN TO 24 V.A.C.

- A. 24 V.A.C. PASSES THRU TO TILT INTERRUPT SWITCH
 - 1. LINE FUSE IS 1.25 AMP SLOW BLOW
- B. 24 V.A.C. PASSES THRU TILT INTERRUPT SWITCH
 - 1. NORMALLY CLOSED / PAN DOWN
- C. 24 V.A.C. PASSES THRU TO HIGH LIMIT
 - 1. NORMALLY CLOSED
 - 2. OPENS AT 450 DEGREES

- D. 24 V.A.C. PASSES THRU TO ELECTRONIC "T" STAT
 - 1. THRU TERMINAL #9
- E. ELECTRONIC "T" STAT
 - 1. TURN KNOB TO DESIRED TEMP. (RESISTANCE)
 - 2. RTD SENSOR COMPARES (SEE RESISTANCE CHART) THRU TERMINALS 3 & 4
 - 3. "T" STAT RESISTANCE > RTD RESISTANCE
 - a. INTERNAL SWITCH CLOSSES SENDING 24 V.A.C. THRU TERM #10 TO IGNITOR MODULE TERM # 2
 - 4. "T" STAT RESISTANCE < RTD RESISTANCE
 - a. INTERNAL SWITCH OPENS DROPPING 24 V.A.C. THRU TERM #10 TO IGNITOR MODULE TERM # 2
- F. IGNITION MODULE
 - 1. POWER TO TERM # 2 COMPLETES IGNITION CIRCUIT TO TERM #3
 - a. OPENS THE GAS SOLENOID
 - b. SENDS MAX. VOLTAGE TO THE IGNITOR
 - c. CREATES SPARK AND LIGHTS BURNERS
- F. THE IGNITOR SENSOR
 - 1. DETECTS FLAME BY SENSING .2 MICRO AMPS BACK TO THE MODULE THROUGH GROUND AND #4 SENSE TERM KEEPING THE GAS SOLENOID OPEN (4 SEC. TRIAL FOR 3 TRIES)
 - 2. IF NO FLAME IS DETECTED THE MODULE WILL TURN OFF THE GAS SOLENOID
- G. HEATING CONTINUES UNTIL "T" STAT = RTD SENSOR
 - 1. EQUAL RESISTANCE DROPS POWER TO IGNITION MODULE (UNTIL PAN COOLS)

*** PROBLEMS AND FIXES

A. TEMPERATURE PROBLEMS

(BULLETINS 95-12 AND 95-4)

1. TEMPERATURE IS NOT CONTROLLABLE OR CONTROL CAN BE INTERMITTENT
 - a. "T" STAT SHAFT KNOB JUMPS STOP
 1. INSTALL CK 149 KIT
(NEW STOP- SHAFT-"T" STAT)
 - b. RTD SENSOR INTERNALLY SHIFTED FROM TIP
 1. REPLACE RTD
2. NO IGNITION (UNITS WITH GALVALUM SQUARED BOTTOM BURNERS OR WITH SAME BURNERS AND ONE S/S BURNER UNDER IGNITOR - EARLY MODELS)
 - a. HOLES IN BURNERS DO NOT LINE UP WITH IGNITOR AND FLAME SENSOR
 1. ORDER PROPER S/S BURNER KIT
3. SKILLET CALIBRATION
 - a. FOR DETERMINING PROPER PAN TEMP.
 1. SEE CALIBRATION HAND OUT

OPTION FOR
POWER TILT

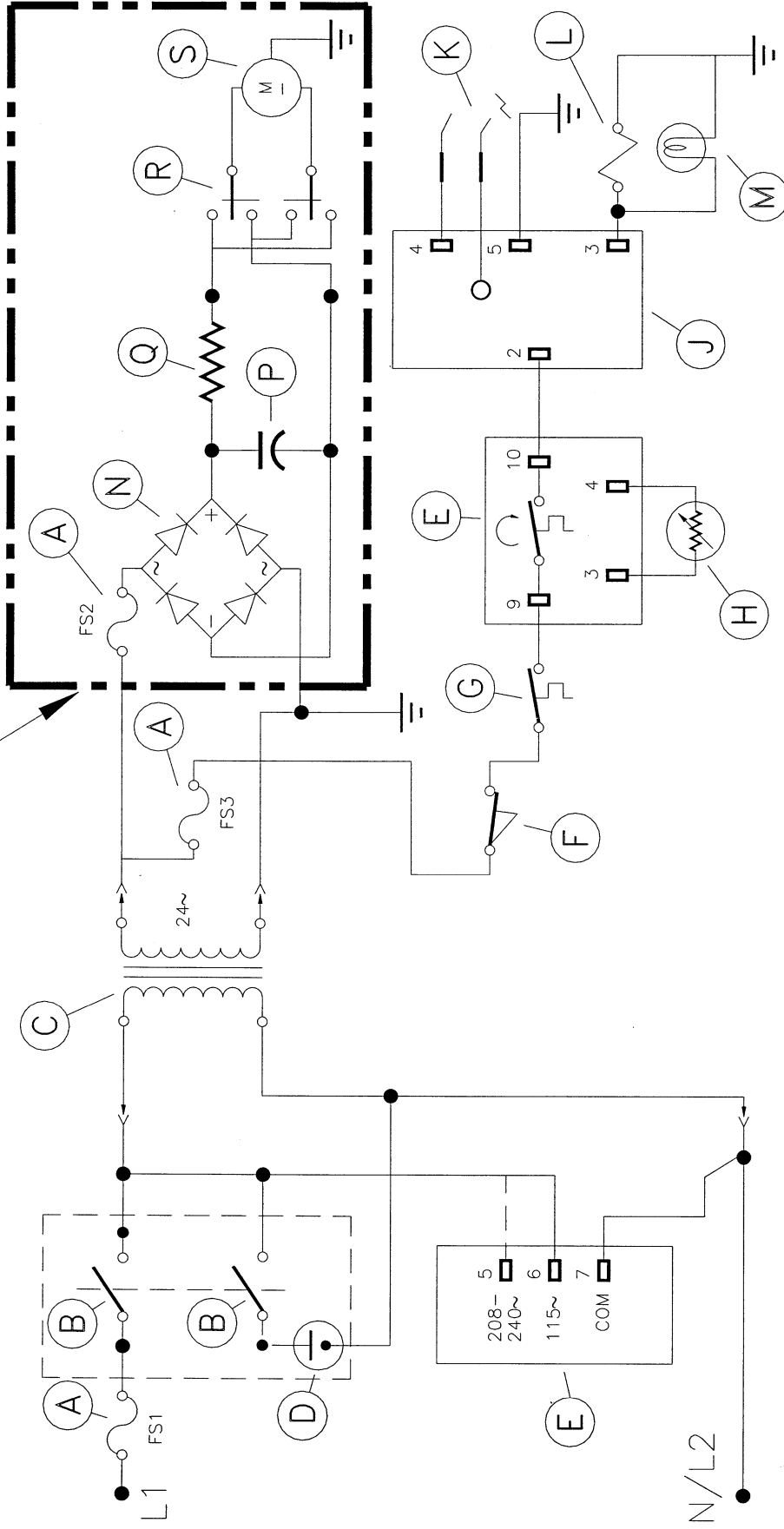

- A - FUSE
- B - POWER SWITCH
- C - TRANSFORMER
- D - PILOT-RED
- E - ELECTRONIC THERMOSTAT
- F - INTERRUPTER SWITCH
- G - HIGH LIMIT SWITCH
- H - RTD SENSOR
- I - IGNITION MODULE
- J - ELECTRODES
- K - GAS BURNER SOLENOID
- L - PILOT-YELLOW
- M - RECTIFIER
- N - CAPACITOR
- P - RESISTOR
- Q - TILT CONTROL
- R - ACTUATOR
- S -

- A - FUSE
- B - POWER SWITCH
- C - TRANSFORMER
- D - PILOT-RED
- E - ELECTRONIC THERMOSTAT
- F - INTERRUPTER SWITCH
- G - HIGH LIMIT SWITCH
- H - RTD SENSOR
- I - IGNITION MODULE
- J - ELECTRODES
- K - GAS BURNER SOLENOID
- L - PILOT-YELLOW
- M - RECTIFIER
- N - CAPACITOR
- P - RESISTOR
- Q - TILT CONTROL
- R - ACTUATOR
- S -

**PROBLEM:
SGL-R
Skillet won't
ignite**

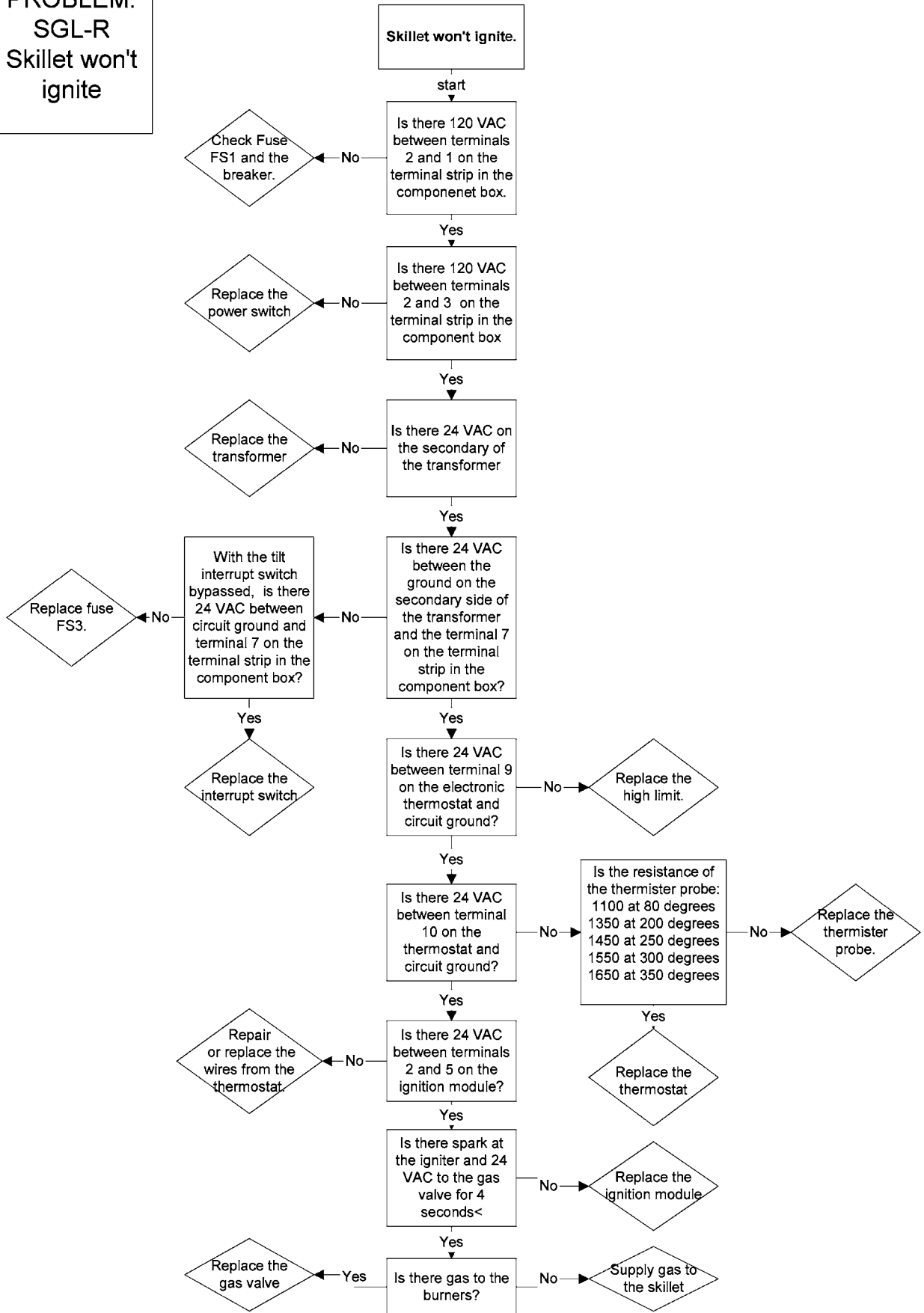

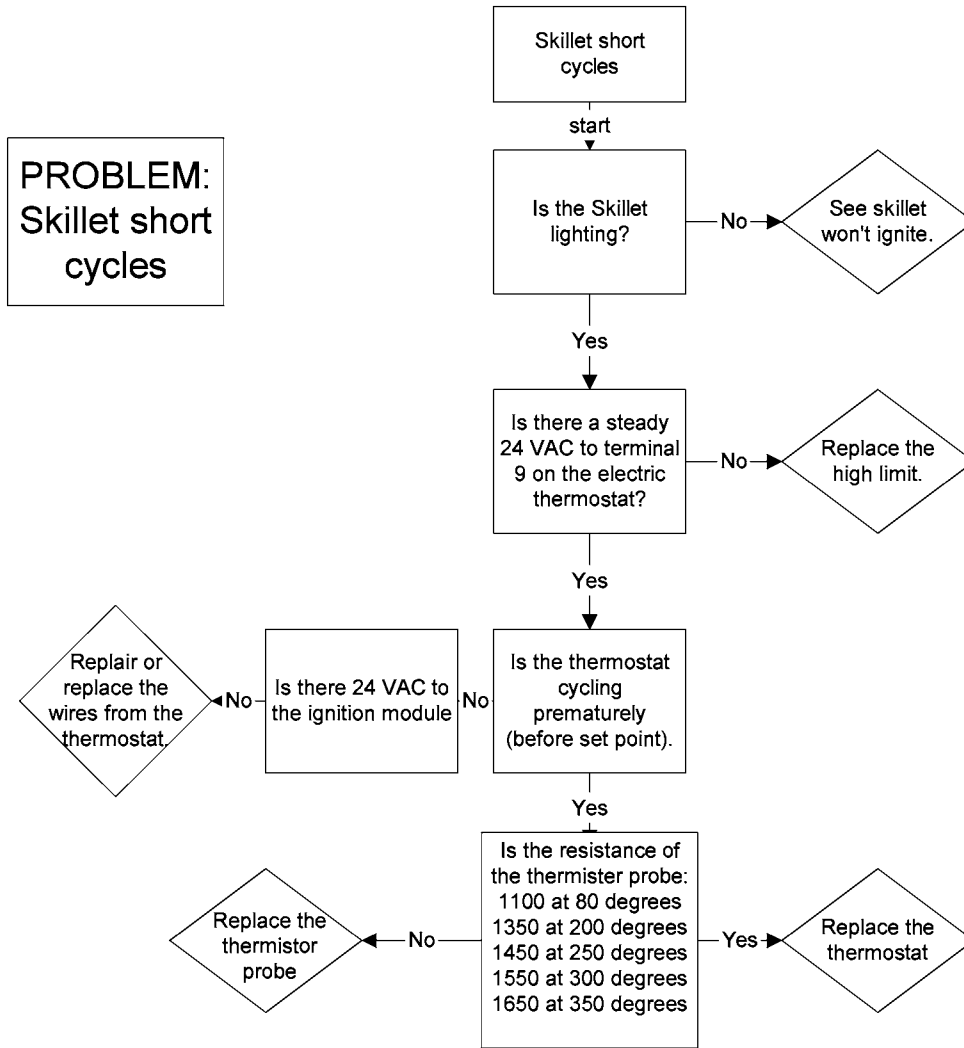

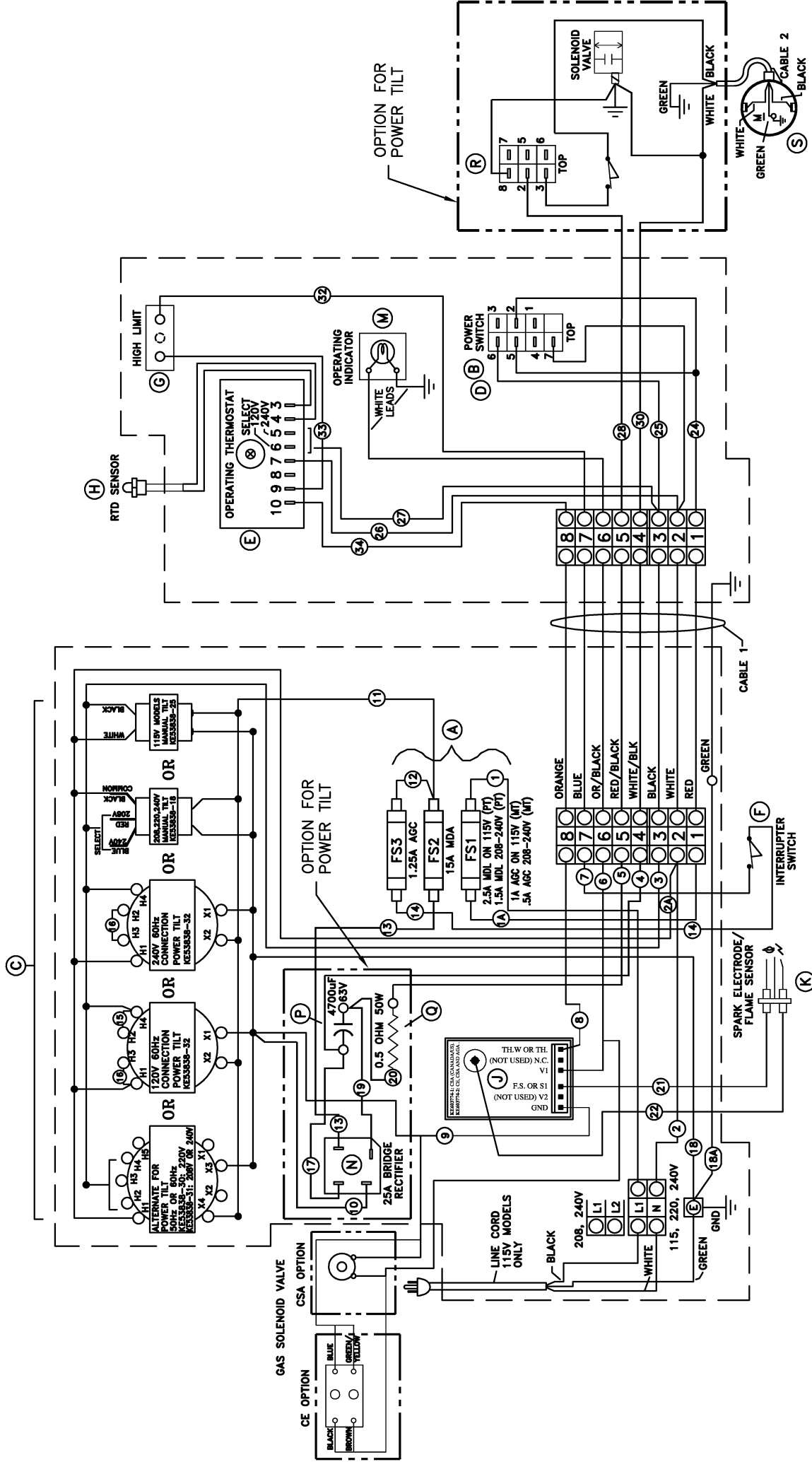

MODEL: SGL,M-30,40TR



Service Bulletin

DIRECT SPARK IGNITION MODULE REPLACEMENT PROCEDURE (FOR KIT NUMBER KE003668)

The following modification must be followed exactly. Due to limited space, any deviations may cause installation problems. With this modification, the Ignition Failure Light (amber LED) will no longer function.

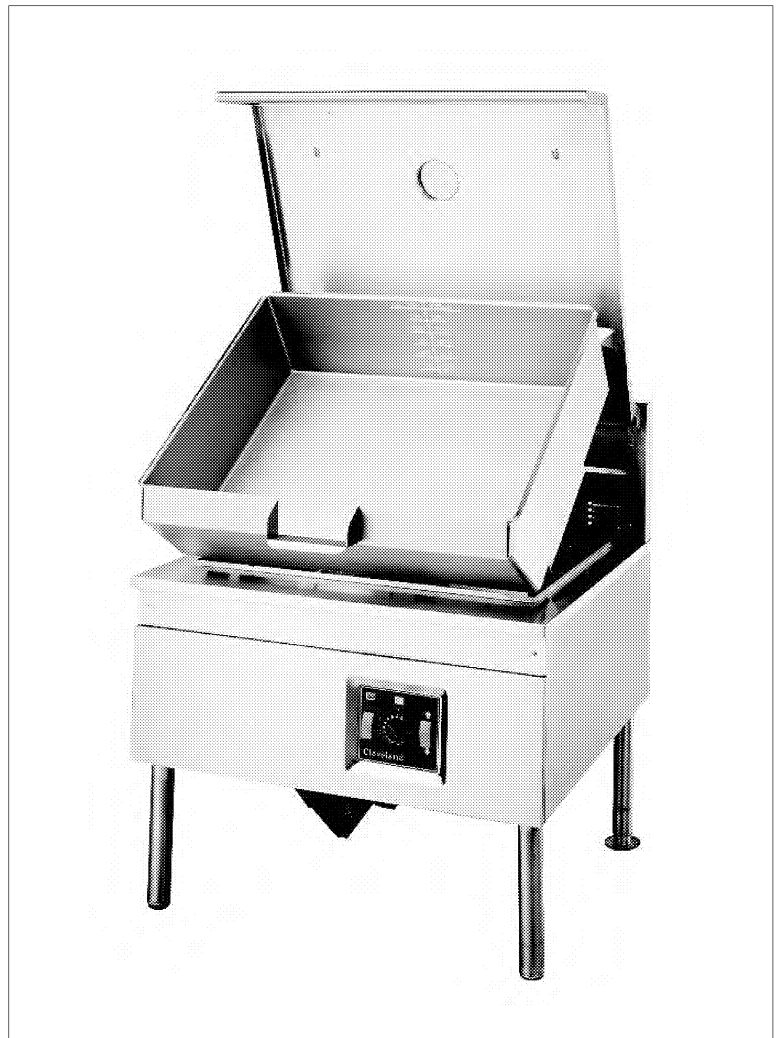

1333 East 179th St.
Cleveland, Ohio
U.S.A. 44110

Phone: (216) 481-4900 Fax: (216) 481-3782
Visit our web site at www.clevelandrange.com

 **Cleveland**

Part #

Old Direct Spark Ignition Module	SK2329100
New Direct Spark Ignition Module	KE603774-1

Prior to proceeding turn off gas supply and shut off power to the Skillet at the fused disconnect switch.

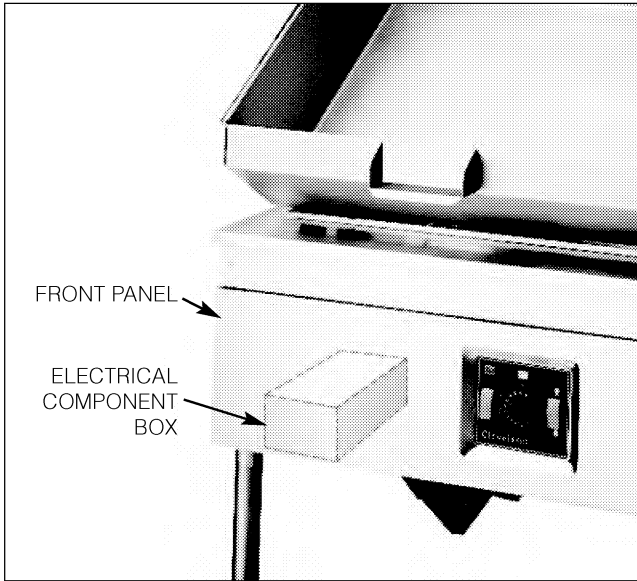

1. Open the front panel and remove cover from ELECTRICAL COMPONENT BOX.

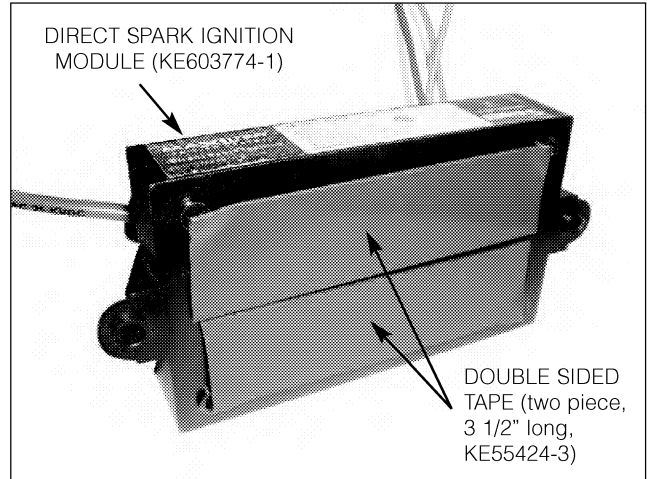

3. Apply DOUBLE SIDED TAPE to the new DIRECT SPARK IGNITION MODULE (KE603774-1)

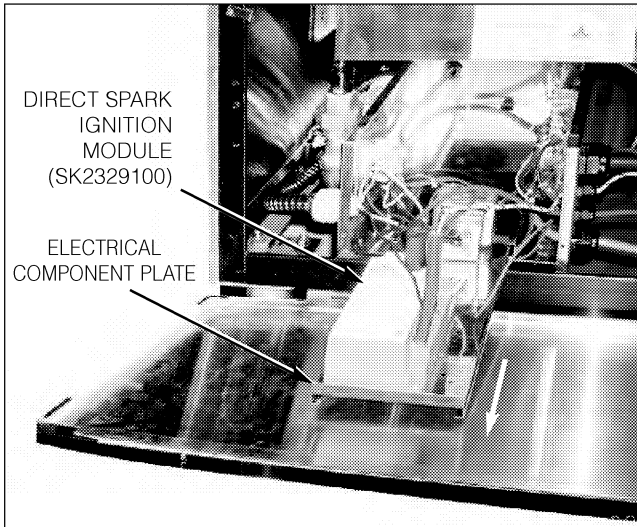

2. Pull out ELECTRICAL COMPONENT PLATE and remove the old DIRECT SPARK IGNITION MODULE (SK2329100).

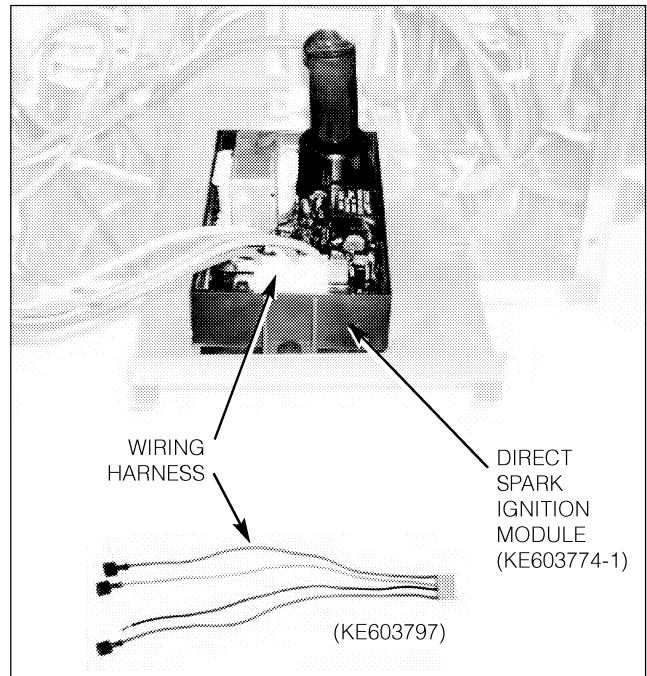

4. Tape the new DIRECT SPARK IGNITION MODULE into place as shown and connect the WIRING HARNESS (KE603797) to the new DIRECT SPARK IGNITION MODULE.

5. Reconnect the new DIRECT SPARK IGNITION MODULE as illustrated.

6. Replace cover on the electrical component box.

7. Close the front panel.

8. Turn ON power to the Skillet at the fused disconnect switch.

9. Turn ON gas supply.

10. Test unit for correct operation.

Connect the following wires:

- GREEN (ignition module) to GREEN (wiring harness).
- ORANGE (ignition module) to ORANGE (wiring harness).
- YELLOW (ignition module) to WHITE with BLUE STRIPES (sensor).
- Cut connectors from ends of existing BLACK and BROWN wires. Connect these two wires to new BROWN wire using a Marr connector. (Part# KE52412)
- Disconnect the solenoid's WHITE wire from the old direct spark ignition module then change the 1/4" push-on terminal with #10 ring connector (part# KE51864) and then connected to the existing ground screw.

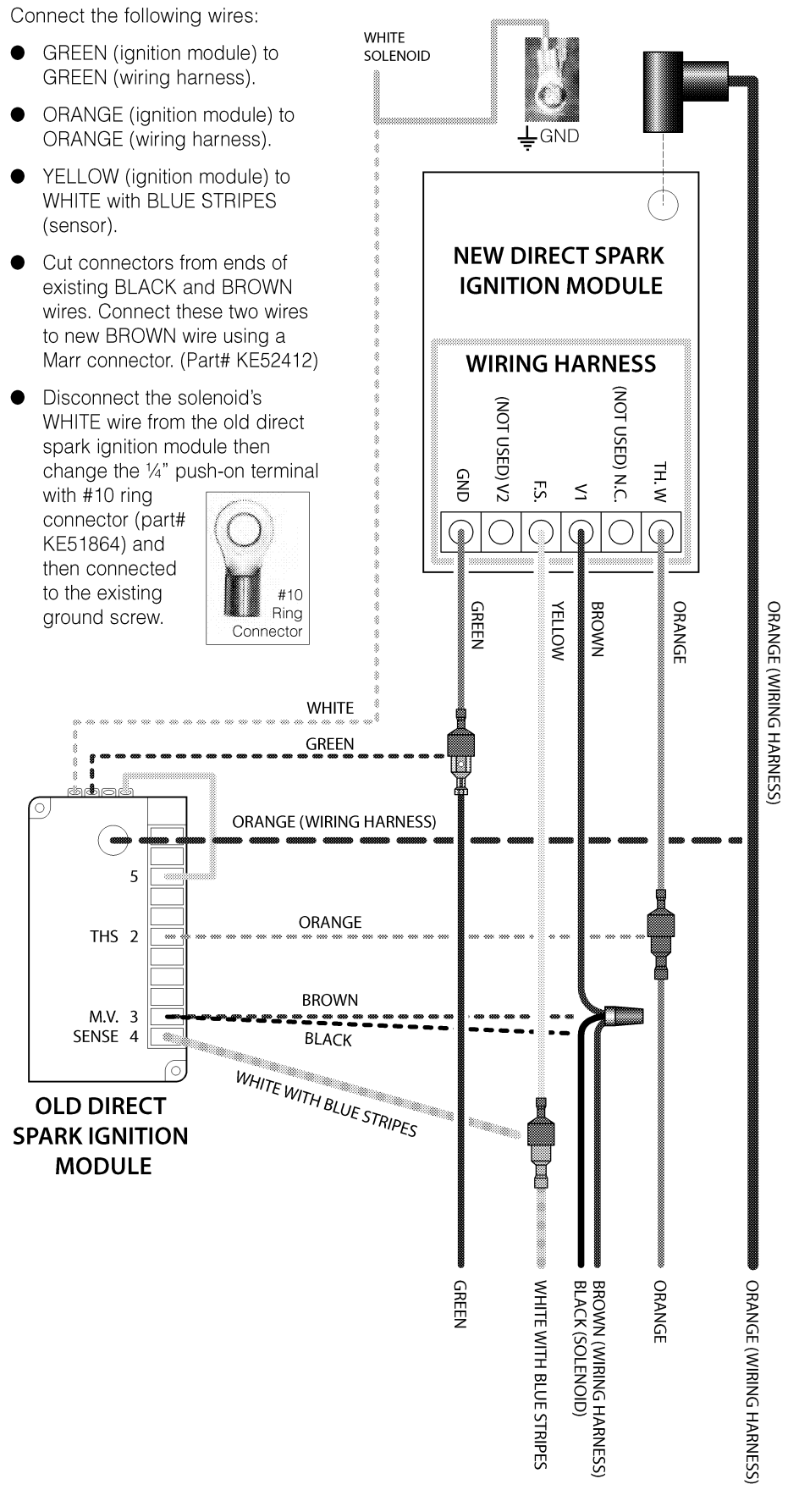
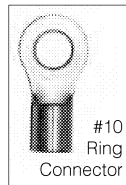

Direct Spark Ignition

24VAC & 120VAC

DXM Series



FEATURES:

- Diagnostic LED Indicator light
- Remote or Local Flame Sensing
- Natural and LP Gas Equipment
- Multiple Tries For Ignition
- Potted or with Integral Stand-Offs
- Custom Pre-Purge & Inter-Purge Timings
- Automatic One Hour Reset

APPLICATIONS:

- Infrared Radiant Heaters
- Commercial Cooking Equipment
- Gas Fired Furnaces, Fire Places and Gas Boilers
- Commercial Water Heaters and Dryers

DESCRIPTION

The model DXM above is a 24 or 120VAC Direct Spark ignition control. The microprocessor circuit design provides precise, repeatable timing and operating sequences. The on-board diagnostics with LED output provides assistance with troubleshooting to ensure a safe and efficient operation.

Full featured design makes it the right choice for any gas fired direct spark appliance and works with both natural and LP gas.

APPROVALS

Software conforms to UL 1998 requirements
Designed to ANSI Z21.20 Standards

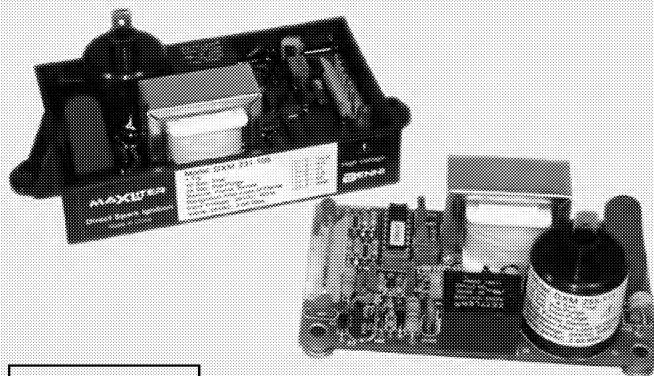

Model DXM

Specifications

INPUT VOLTAGE	- 18-30VAC 50/60 Hz (Class 2 Transformer) or - 102-138VAC 50/60 Hz
CURRENT DRAW MAIN VALVE	2.0A @ 24VAC or 120VAC
INPUT CURRENT DRAIN	300 mA @ 24VAC, 350 mA @120VAC
VALVE CONTACT RATING	2.0A @ 24VAC, 1.5A@ 120VAC
OPERATING TEMPERATURE	-40F to 175F, -40C to +80C
TYPES OF GASES	Natural, LP, or Manufactured
FLAME SENSITIVITY	0.7uA Minimum
SPARK RATE	50/60 Hz (Line Frequency)
FLAME FAILURE RESPONSE	0.8 Seconds Maximum
SIZE (L x W x H)	4.00 x 2.30 x 1.50 inches
ENCLOSURE	Potted or Integral Stand Offs
MOISTURE RESISTANCE	CONFORMAL COATED OR POTTED TO 95% R.H. AVOID DIRECT EXPOSURE TO WATER
WEIGHT	

ON BOARD DIAGNOSTICS

LOCKOUT MODE	LED INDICATION
Ignition Failure	2 Flashes
Exceed Flame Lost	3 Flashes
MCU Failure or Flame Exists	4 Flashes

Main Offices/Warehouse:



3267 Grapevine Street
Mira Loma, CA 91752
TEL: 951-360-5537
FAX: 951-360-5329

Web: www.bennitech.com

Ordering Information

DXM	X	X	X	X	-	X	X	X		DESCRIPTION
										RESET METHODS AND ENCLOSURE
										2 = POWER OFF RESET - POTTED
										3 = AUTOMATIC RESET - POTTED
										4 = POWER OFF RESET - INTEGRAL STAND OFFS WITH NO COVER
										5 = AUTOMATIC RESET - INTEGRAL STAND OFFS WITH NO COVER
										FLAME SENSING METHOD
										R = REMOTE SENSE (DUAL ROD)
										L = LOCAL SENSE (SINGLE ROD)
										TRIAL FOR IGNITION
										1 = 4 SECONDS
										2 = 7 SECONDS
										5 = 10 SECONDS
										INTER-PURGE
										0 = NONE (Single Try Models Only)
										1 = 15 SECONDS
										2 = 30 SECONDS
										PRE-PURGE
										0 = NONE
										1 = 15 SECONDS
										2 = 30 SECONDS
										TRIES FOR IGNITION
										1 = SINGLE TRY ONE HOUR AUTO RESET
										2 = THREE TRIES ONE HOUR AUTO RESET
										3 = SINGLE TRY NO ONE HOUR RESET
										4 = THREE TRIES NO ONE HOUR RESET
										INPUT VOLTAGE
										2 = 24VAC
										3 = 120VAC
										9 = CUSTOM SPECIAL OEM CONFIGURATION
										DXM = DIRECT SPARK IGNITION CONTROL MaxLiter Series

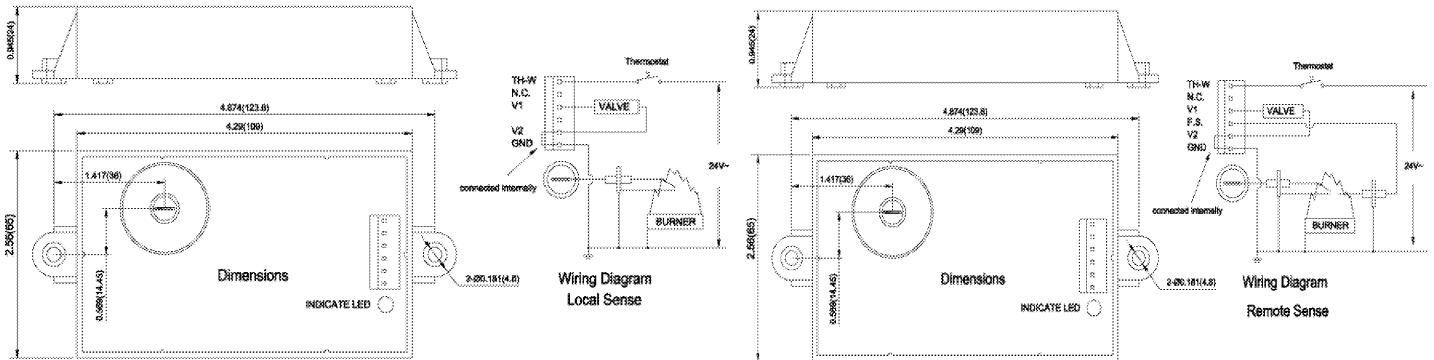

DISCONNECT THE POWER SUPPLY BEFORE MAKING WIRING CONNECTIONS TO PREVENT ELECTRICAL SHOCK OR EQUIPMENT DAMAGE.

EXPLOSION HAZARD. CAN CAUSE INJURY OR EQUIPMENT DAMAGE.

Only trained professional gas appliance service technicians should install and check out this control.

Power Pan™ SERIES

GAS, 35" RIM HEIGHT,
30 & 40 GALLON (110 & 150 LITER)

MODELS: SGL-30-T1
 SGL-40-T1

Cleveland Standard Features

- Available in 30 & 40 gallon (115 & 150 liter) open frame design models. Full capacity to bottom of pouring lip.
- Exclusive Ultra Efficient Power Burner (Forced-Air) Gas Combustion System with Automatic Ignition.
- Exclusive Dual Power Settings: 90,000 and 125,000 Btu for 30 gallons, 160,000 Btu and 200,000 Btu for 40 gallons provides superior heat-up and recovery.
- Open base design for easy cleaning and maintenance.
- 5/8" Stainless Steel Bead Blasted cooking surface prevents warping and keeps food from sticking.
- Durable 12 gauge, 304 Stainless Steel pan construction. 5/16" (16mm) mild steel clad bottom plus a 1/16" (1.6mm) Stainless Steel plate for even temperature distribution.
- Low 35" rim height for easy operation and cleaning.
- Splash Proof Controls and construction.
- Supplied with Cord & Plug for 115-volt controls.
- Easy-to-turn manual hand tilt with enclosed permanently lubricated gearbox. Optional power tilt with manual override available.
- Gallon/Liter Markings and Vented Spring Assist Cover standard.
- Available with Optional 2" Tangent Draw-Off Valve.
- 10° Cooking Feature. Tilt unit up to 10° without the power being turned off.
- Adjustable, Electronic Thermostat accurately controls temperature from 100° to 450° F.
- Electronic "Spark Ignition System Standard".
- Spring-Assist Cover with full width handle and vent.
- Typical approvals include AGA, CSA, CE and NSF.

Options & Accessories

- Power Tilt with Manual Override (PT2)
- 2" (50 mm) Tangent Draw-Off Valve (TD2SK), left side only
- Double or Single Pantry Faucet (SPS14, DPS14), includes Faucet Mounting Bracket
- Faucet Bracket (FBKT1)
- Pan Carriers (PCS), not available on 30 gallon models with a Tangent Draw-Off Valve
- Vegetable Steamer Baskets (VS)



Shown with optional 2" Tangent Draw Off Valve

Short Form Specifications

Shall be CLEVELAND, Tilting Skillet Model Number SGL-____-T1, gas (type____) holding no less than ____ gallons (____ liters); Complete with Dual Power Setting, Normal and High Power Cooking Controls, Power Burner (Forced-Air) Gas Combustion System, Automatic Ignition, Splash-Proof Construction, Spring Assist Cover with Vent, Gallon/Liter Markings, 5/8" Stainless Steel Clad Cooking Surface with Bead Blasted Finish, Easy to use Manual Hand Tilt with Enclosed Permanently Lubricated Gearbox, Adjustable Feet with Rear Flanged and Front Bullet Style.

- Hot & Cold Water Pre-Rinse Spray Head with Hose (PRS-S)
- Poaching Pans (PP)
- Voltage Option:
 - VOSK3, 440/480 Volt, 60 Hz, 3 Phase
 - VOSK4, 220/240 Volt, 50 Hz, 1 Phase - for export
- Protective Control Cover (CP-PCB-T1)
- Casters, 2 swivel, 2 locking (CST1)

DIMENSIONS

MODEL	A	B	C	D	E	E	F	G	H
						(non-combustible wall)			
SGL-30-T1	37 7/8"	24 1/2"	31 3/4"	12"	3 1/2"	2	18 1/4"	5 3/4"	8"
	(963mm)	(623mm)	(807mm)	(305mm)	(89mm)		(464mm)	(146mm)	(204mm)
SGL-40-T1	49 7/8"	36 1/2"	43 3/4"	18"	3 1/2"	2	24 1/4"	5 3/4"	8"
	(1267mm)	(928mm)	(1112mm)	(458mm)	(89mm)		(616mm)	(146mm)	(204mm)

SPECIFICATIONS

ELECTRICAL SUPPLY		GAS SUPPLY (PIPING 3/4" NPT)		CLEARANCE		APPROX. SHIPPING WEIGHTS	
VOLTS:	120 220/240	TYPE:	NAT or LP	RIGHT:	4" (102mm) (manual tilt)	SGL-30-T1	
PHASE:	1 1	WATER COLUMN:	3.5 (NAT), 10 (LP)	LEFT:	1" (26mm) (power tilt)	520 LBS.	
AMPS:	1.4 1.5	BTU PER CU. FT.:	1025 (NAT), 2500 (LP)	REAR:	0" (non-combustible wall)	235 KG.	
FREQ.:	60 HZ 50 HZ	SUPPLY PRESSURE:	5" W.C. MIN (NAT), 11" W.C. MIN (LP)		3.5" (89mm) (combustible wall)	SGL-40-T1	
		BTU RATINGS:				560 LBS.	
		SGL-30-T :	125,000 per hour			255 KG.	
		SGL-40-T :	200,000 per hour				

CAPACITIES

In 4 oz. servings. Other sizes may be calculated.
 30 gallons / 115 Liters.....960
 40 gallons / 150 Liters.....1280

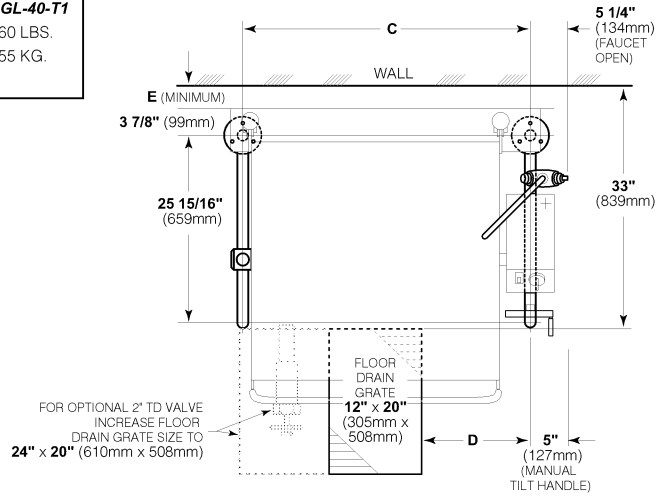
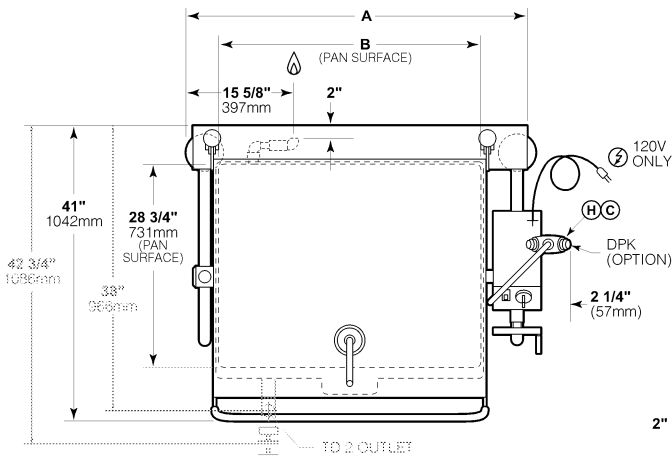

LEG LOCATION & SUGGESTED FLOOR DRAIN DETAIL

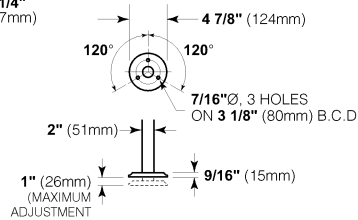

FLANGED FOOT DETAIL (REAR LEGS ONLY)

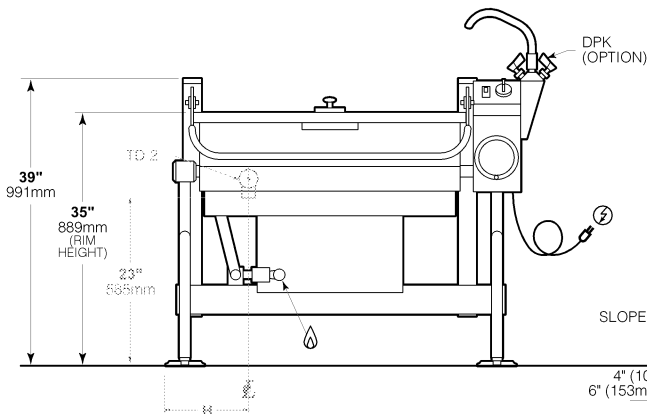

NOTE: OPTIONAL 2" TD VALVE SHOWN IN GRAY

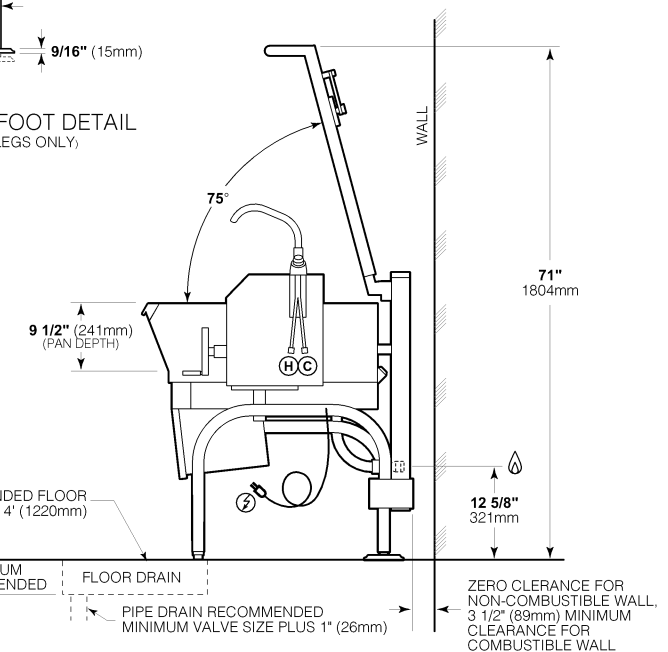

ZERO CLEARANCE FOR NON-COMBUSTIBLE WALL, 3 1/2" (89mm) MINIMUM CLEARANCE FOR COMBUSTIBLE WALL

NOTES:

Cleveland Range reserves right of design improvement or modification, as warranted. Many regional, state and local codes exist and it is the responsibility of the owner and installer to comply with the codes. Cleveland Range equipment is built to comply with applicable standards for manufacturers. Included among those approval agencies are U.L., NSF, CGA, CSA, ETL and others.

(NOT TO SCALE)

SECT. XII PAGE 12

0609

Litho in U.S.A.

CLEVELAND RANGE SGL T1 SEQUENCE OF OPERATIONS

When using these instructions refer to the SGL-T1 wiring schematic.

1. 115 VAC is sent through the 3 amp fuse to
 - The primary of the 24 VAC transformer
 - 24 VAC is sent from the secondary of the 24VAC transformer to the Hi/Off/Low Switch.
 - Contacts of the R1 Blower Relay
 - The optional Power Tilt Circuit
2. With the Hi/Off/Low switch in the Low position.
 - 24 VAC is sent through the normally closed high limit switch to the mercury switch.
 - If the skillet is in the down position then 24 VAC is sent through mercury switch to pin 9 on the thermostat.
3. With the Hi/Off/Low Switch in the Hi position 24 VAC is also sent to the Hi terminal on the gas valve.
 - Gas will not leave the valve until the main gas valve opens (see step 7).
4. If the skillet is calling for heat the 24 VAC is sent from pin number 10 to R1 Blower Relay.
 - The normally open contacts of the blower relay close sending 115 VAC to the blower.
 - The blower turns closing the air switch.
 - 24 VAC is sent through the now closed air switch to the ignition module.
5. Ignition module sends spark from terminal SP to the igniter.
6. Ignition module also sends 24 VAC from pins PV and MV/PV to the pilot coil of the gas valve pins P and C.
 - Pilot valve opens sending gas to the Pilot assembly.
 - Spark and gas meet and pilot is ignited.
 - AC current is passed through the flame and rectified then sent back to the ignition module.
7. If the ignition module reads a minimum of 1.0 micro-amps through the burner ground then 24 VAC is sent from pins MV and MV/PV of the ignition module to pins M and C on the Gas valve.
 - The main (low) gas valve opens and gas (3.0" W.C. natural gas or 8.0" W.C. LP) is sent to the burner.
 - If the skillet is in the Hi position (see step 3) 24VAC will be at the HI terminal and the gas pressure will be 3.5" W.C. natural or 10.0" W.C. LP.

- Burner ignites until thermostat is satisfied.
8. When thermostat is satisfied, 24 VAC is removed from pin 10 on the thermostat and the heat circuit is de-energized
 9. If the skillet has the optional Power Tilt option and is in the down position, 115 VAC is sent from the customer connect through the circuit breaker and the up limit switch to the tilt switch.
 10. With the tilt switch in switch in the Up position
 - 115 VAC is sent to the Bridge Rectifier
 - 115 VDC is sent from the rectifier through the 30-ohm resistor to the normally open RY10 and RY11 relay contacts.
 - 115 VAC is sent to the RY10 relay coil.
 - The normally open RY10 contact close and 90 VDC is sent to the DC motor
 - The DC motor is energized and the skillet tilts until the switch is released or the up limit switch opens.
 11. With the Tilt switch in the Down position
 - 115 VAC is sent to the Bridge Rectifier
 - 115 DC is sent from the rectifier through the 30-ohm resistor to the normally open RY10 and RY11 relay contacts.
 - 115 VAC is sent to the RY11 relay coil.
 - The normally open RY11 contact close and the polarity of the 90 VDC is reversed.
 - The DC motor is energized and the skillet lowers until the switch is released or the Down limit switch opens.



NOT INCLUDED, USED FROM EXISTING ASS'Y

NOT INCLUDED, USED FROM EXISTING ASS'Y

P/N F105304; COMES WITH VALVE

REV.	ITEM	PART NUMBER	DESCRIPTION	QTY	QTY
A	-	KE003671-1	SERVICE KIT; NATURAL GAS (NAT)	1	1
A	-	KE003671-2	SERVICE KIT; LIQUID PROPANE (LP)	1	1
	1	SK24882-1	GAS VALVE (NAT)	1	-
	1	SK24882-2	GAS VALVE (LP)	1	-
	2	F105234	HEX COUPLING; 3/4 - 1 1/2	1	1
	3	N0640B1.5	NIPPLE; 3/4 - 1 1/2	1	1
	4	SK24913-2	1/4 TUBING COMP.; GAS VALVE	1	1
	5	F105198-1	1/4 X 1/8 NPT 90° ELBOW	1	1
	6	G02251-1	TEST SPIGOT	1	1

THE DESIGN COVERS A PROPRIETARY ITEM AND IS THE PROPERTY OF CLEVELAND RANGE LTD. THIS DRAWING IS NOT TO BE COPIED OR USED WITHOUT THE APPROVAL OF CLEVELAND RANGE LTD.		THE DESIGN COVERS A PROPRIETARY ITEM AND IS THE PROPERTY OF CLEVELAND RANGE LTD. THIS DRAWING IS NOT TO BE COPIED OR USED WITHOUT THE APPROVAL OF CLEVELAND RANGE LTD.	
MATERIAL TYPE & GRADE FORM SIZE FINISH		TITLE GAS VALVE SERVICE KIT SGL-30/40 T1; NG / LP	
DO NOT SCALE PRINTED DRAWING		DRAWN BY H.JAMSHIDI	DATE 02/19/2009
SHEET NO. KE003671.DWG		SIZE B	REV A

New style flue installation instructions

Review and familiarize yourself with these instructions and all parts before starting this retrofit.

Parts: Check Flue Diverter Final Assembly drawing to ensure all parts listed are supplied.

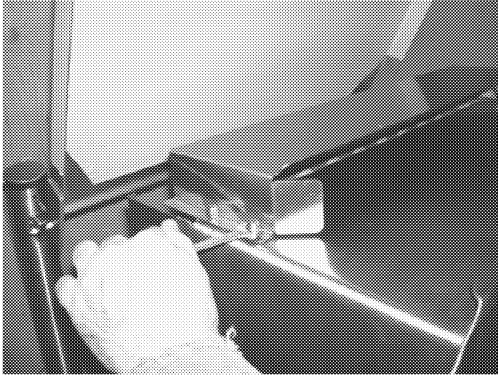

Remove Flue Cover

With the skillet in the tilted position remove the 4 acorn nuts holding the flue in place and remove the flue.

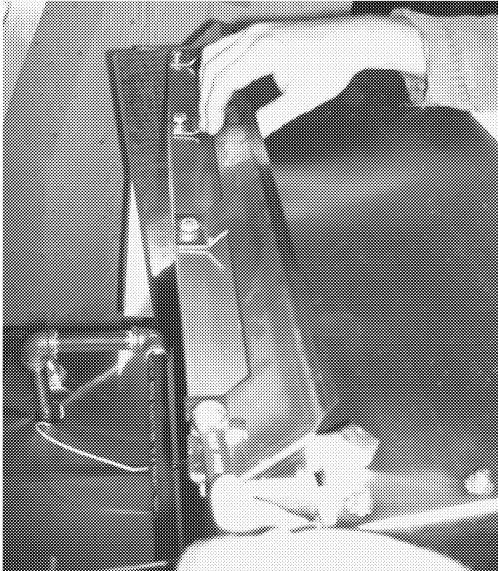

Remove Flue Deflector

Remove the 4 bolts holding the flue deflector and remove flue deflector.



Loosen Side Panel

Remove rear nut holding side panel.



Install Filler Piece

Insert filler piece Items 17 & 18 (Note left and right parts are different) on the stud at the back as shown. Install nut hand tight.



Ensuring surface of filler piece and back of skillet are flush. Tighten nut. Repeat on the opposite side.

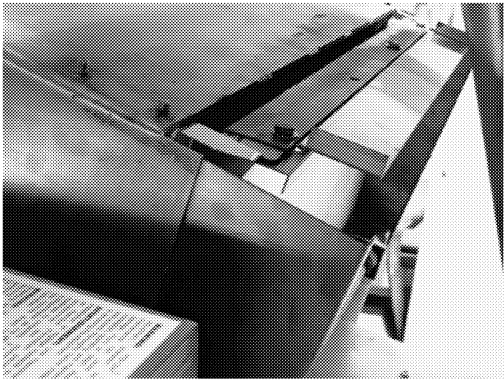

Install Angle & Flue Back

Install the Flue back & angle (Items 26 & 9) on the back side of the burner pan lip and insert and tighten bolts as shown.

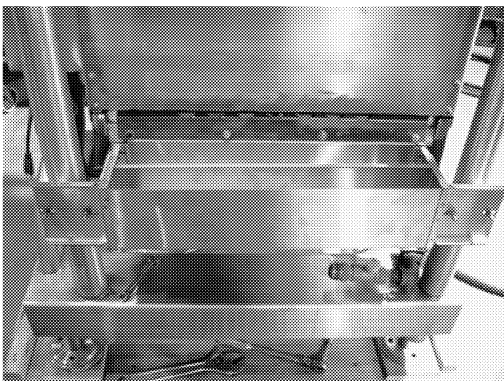

Install Flue Channel

Install Frame Clamps (Item 10) to flue channel (Item 1) and mount this assembly to the frame posts using the frame clamps (Item 11) and hand tighten bolts.

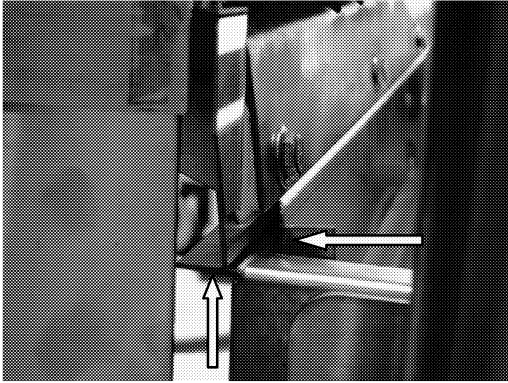

Locate Flue Channel

With the skillet in the upright (operating) position.

Slide flue channel up until Flue Back (Item 26) fits down inside the flue and the flange on flue channel (Item 1) and the flange (Item 9) mounted on the burner pan fit flush. The flue back should touch the back of the flue channel.

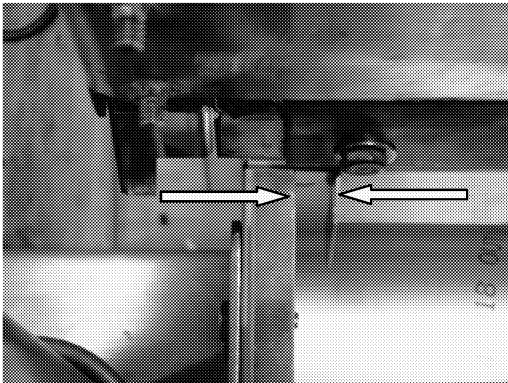

Ensure that the flue back is centered in the flue channel.

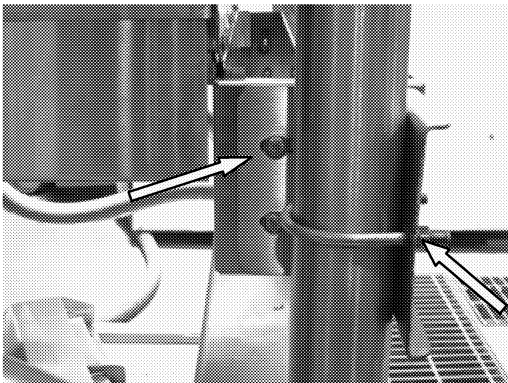

Tighten bolts

Once you are certain that the flue is in the correct location tighten all the bolts.

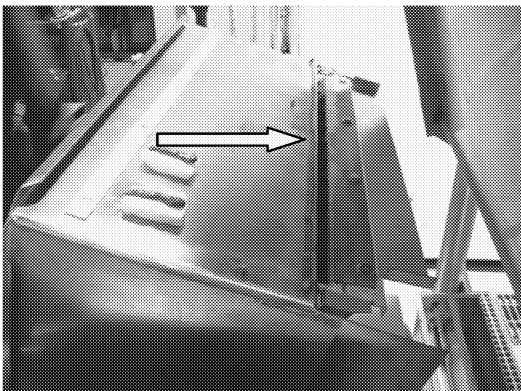

Insulation gaskets

Apply a bead of silicon to the back of the pan just above the flue opening as shown and to the back of both insulation end pieces.

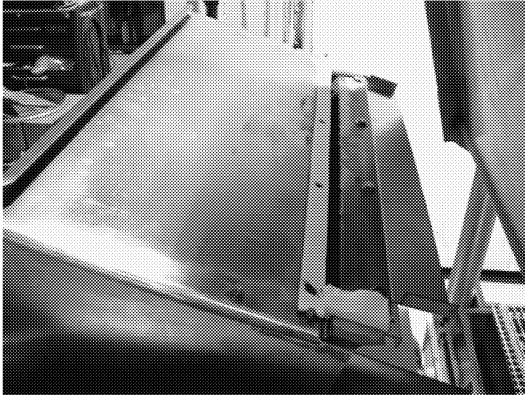

Install insulation pieces as shown being certain that the strip above the flue opening does not cover flue opening at all.



Silicon

Apply a ¼” bead of silicon to the back of the Flue front (Item 2) on three edges, the top and both sides as shown.



Install flue front

Hook the top edge of the flu front under the pan lip. Lower flue into place aligning the holes with the studs on the back of the pan and making certain the flue back fit inside of the flue front.



Install and tighten acorn nuts. (NOTE; on 40 gal. install 2 nuts & lockwasher on studs from the back).

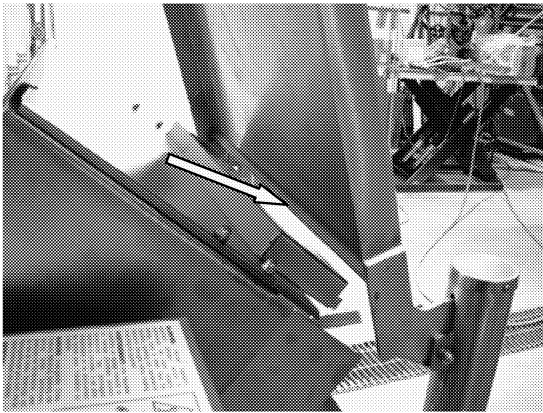

Flue mounting Inspection

Ensure cover opens to the full upright position. Tighten cover springs if required. Tilt pan up and down and check for clearances between flue and cover.



Tilt skillet to upright position and check clearances at flue.

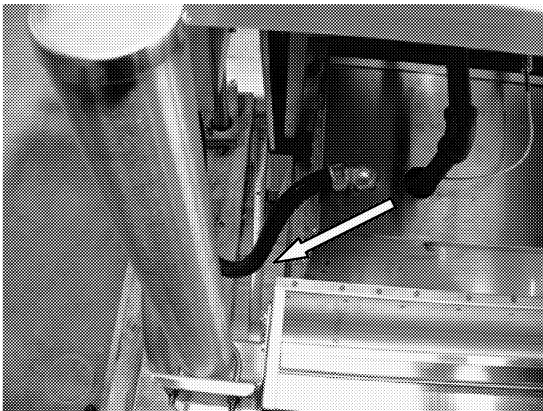

Ensure electrical conduit does not hit the flue when tilting the skillet. If it does loosen the fitting and rotate it to the position shown.

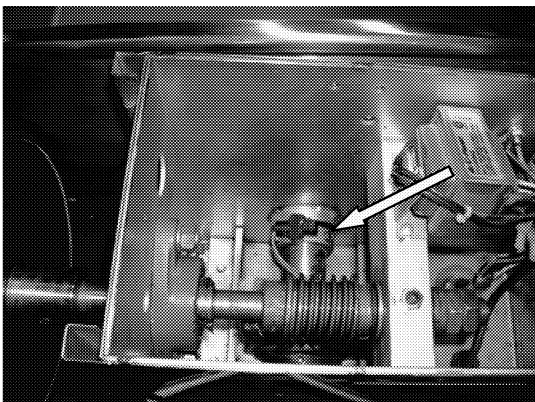

Tilt switch adjust

Adjust tilt switch by loosening the set screw on the mounting collar and rotating it so that the skillet will shut off when the flue is still at least 1/4" inch into the flue channel at the back as shown in the next picture.

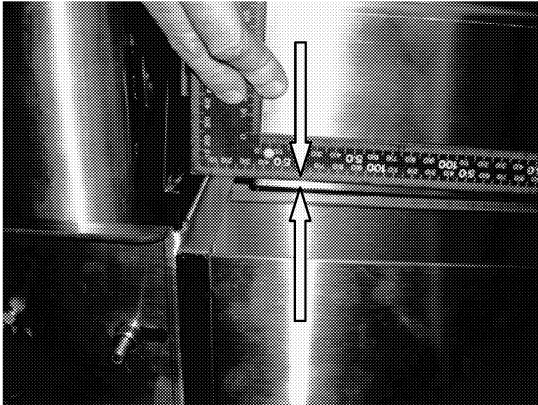

Confirm clearances

Set thermostat to maximum and heat the skillet until it cycles off. Recheck clearances and adjust as required.



Installing Label

Remove old label and clean console cover. Install new label.

IMPORTANT: NOTIFY MANAGEMENT AND STAFF THAT SERIOUS DAMAGE TO EQUIPMENT WILL BE CAUSED BY HOSING BACK OF UNIT AND GETTING WATER INTO FLUE.

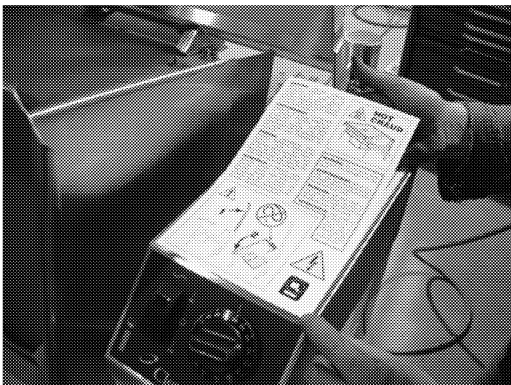

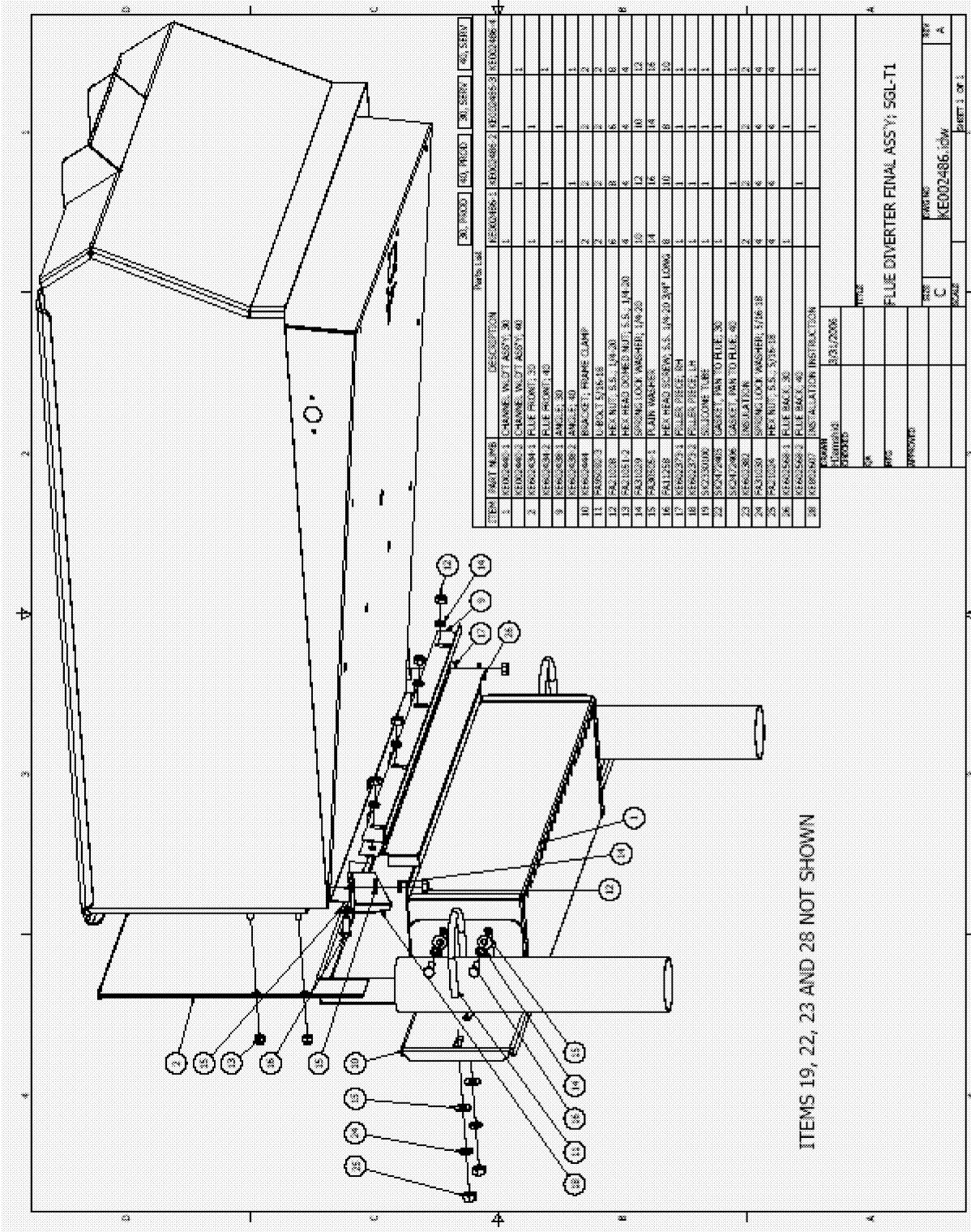

ITEMS 19, 22, 23 AND 28 NOT SHOWN

ITEM	PART NUMBER	DESCRIPTION	QTY	UNIT	REVISION	DATE	BY
1	84620486-1	CHARMEL W/ST ASSY, 30	1		1		
2	84620486-2	CHARMEL W/ST ASSY, 40	1		1		
3	84620486-3	FILE PROOF, 30	1		1		
4	84620486-4	FILE PROOF, 40	1		1		
5	84620486-5	FILE PROOF, 50	1		1		
6	84620486-6	FILE PROOF, 60	1		1		
7	84620486-7	FILE PROOF, 70	1		1		
8	84620486-8	FILE PROOF, 80	1		1		
9	84620486-9	FILE PROOF, 90	1		1		
10	84620486-10	FILE PROOF, 100	1		1		
11	84620486-11	FILE PROOF, 110	1		1		
12	84620486-12	FILE PROOF, 120	1		1		
13	84620486-13	FILE PROOF, 130	1		1		
14	84620486-14	FILE PROOF, 140	1		1		
15	84620486-15	FILE PROOF, 150	1		1		
16	84620486-16	FILE PROOF, 160	1		1		
17	84620486-17	FILE PROOF, 170	1		1		
18	84620486-18	FILE PROOF, 180	1		1		
19	84620486-19	FILE PROOF, 190	1		1		
20	84620486-20	FILE PROOF, 200	1		1		
21	84620486-21	FILE PROOF, 210	1		1		
22	84620486-22	FILE PROOF, 220	1		1		
23	84620486-23	FILE PROOF, 230	1		1		
24	84620486-24	FILE PROOF, 240	1		1		
25	84620486-25	FILE PROOF, 250	1		1		
26	84620486-26	FILE PROOF, 260	1		1		
27	84620486-27	FILE PROOF, 270	1		1		
28	84620486-28	FILE PROOF, 280	1		1		

ITEM	DESCRIPTION	QTY	UNIT
1	FLUE DIVERTER FINAL ASSY; SGL-T1	1	

