

Technical Training Handbook and Reference Guide



**Technical Training Handbook
and
Reference Guide**

**Section 6 :
Boiler Free**

Boiler Free

Table of Contents

• 1SCE	1
• 22CET3.1	11
• 22CET6.1	13
• Cast Heater Block	27
• 22CGT3.1	32
• 22CGT6.1	34



STEAMCUB™ BOILERLESS CONNECTIONLESS STEAMER

Project _____
 Item _____
 Quantity _____
 FCSI Section _____
 Approval _____
 Date _____

SteamCub™

PRESSURELESS STEAM COOKER,
RETHEMALIZER & HOLDING CABINET

MODEL: 1SCMCS



Cleveland Standard Features

- Boilerless Pressureless Steam Cooker and Rethermalizer.
- Capacity: Full Size Steam Table Pans:
 - Five: 2 1/2" x 12" x 20" (1/1 GN, 65mm)
 - Ten: 1" x 12" x 20" (1/1GN, 40mm)
- Easy installation, no drain line or water connections are required.
- 60 Mechanical Timer with ON/OFF Main Power Switch with a Heat On, Low Water Indicator Lights and High Temperature Safety Light and Shut-off (Reset Light).
- 6" (152mm) Skid Resistant Stainless Steel Adjustable Legs with Flanged Feet.
- 8 gauge stainless steel inner cooking compartment, 14 gauge stainless steel outer compartment with two piece compartment door for an airtight, leak-proof seal.
- Reversible Door Gasket.
- 9 kW total output, with easy to remove 1 kW heating elements (9 each) cast into aluminum blocks.
- Electronic Low-Water Shut-Off Safety Indicator with audible alarm, High Temperature Safety Shut-Off and LED "Heat On" Indicator Light.
- Separate Power ON/OFF Control includes an Automatic Pre-Heat when power is turned "ON".
- Easy-Access Manual Drain Valve located in front, Pan Slide Guides located under unit to fit 12" x 20" (1/1GN) Pans. Includes one 4" x 12" x 20" stainless steel pan (1/1GN-102mm).
- Approvals: cUL, NSF #4.

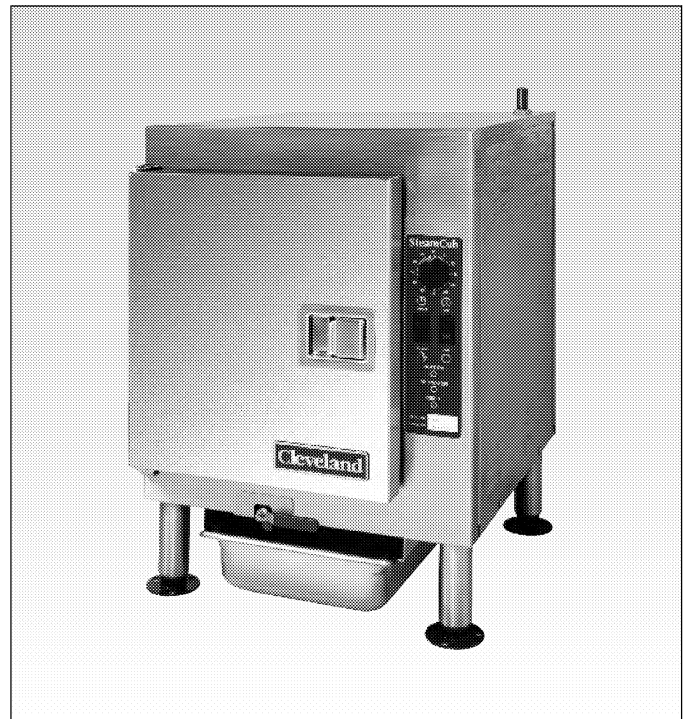

Short Form Specifications

Shall be a Cleveland SteamCub™, Model 1SCMCS, one compartment steamer. 60-minute mechanical timer with a low water indicator and alarm. a heat-on indicator light. 9 kW power rating. Capacity for five 2 1/2" deep full size steam table pans. 8 gauge stainless steel inner cooking compartment, 14 gauge stainless steel outer compartment with two piece compartment door.

Options & Accessories

- Equipment Stand Model UniStand34.
- POSK Pull-Out Shelf Kit for UniStands (P/N 111724)
- URK Pan Rack Kit UniStands (P/N 111726)
- Optional Voltages, 480 Volt (VOS2).
- 6 kW total Output Six - 1 kW heating elements.
- Single Phase Operation.

SECT. I PAGE 1
0109



WATER QUALITY REQUIREMENT

The recommended minimum water quality standards whether untreated or pre-treated, based upon 10 hours of use per day, and a Daily Blowdown, are as follows:

TOTAL DISSOLVED SOLIDS	less than 60 parts per million
TOTAL ALKALINITY	less than 20 parts per million
SILICA	less than 13 parts per million
pH FACTOR	greater than 7.5
CHLORINE	less than 30 parts per million

Consult a local water treatment specialist for an on site water analysis for recommendations concerning steam generator feed water treatment (if required), in order to remove or reduce harmful concentrations of minerals. The use of highly mineralized water will mean that more frequent servicing of the steam generator will be necessary. The fact that a water supply is potable is not proof that it will be suitable for the generator.

- Compartment has capacity for:
Five, 12" x 20" x 2½" deep Cafeteria Pans.

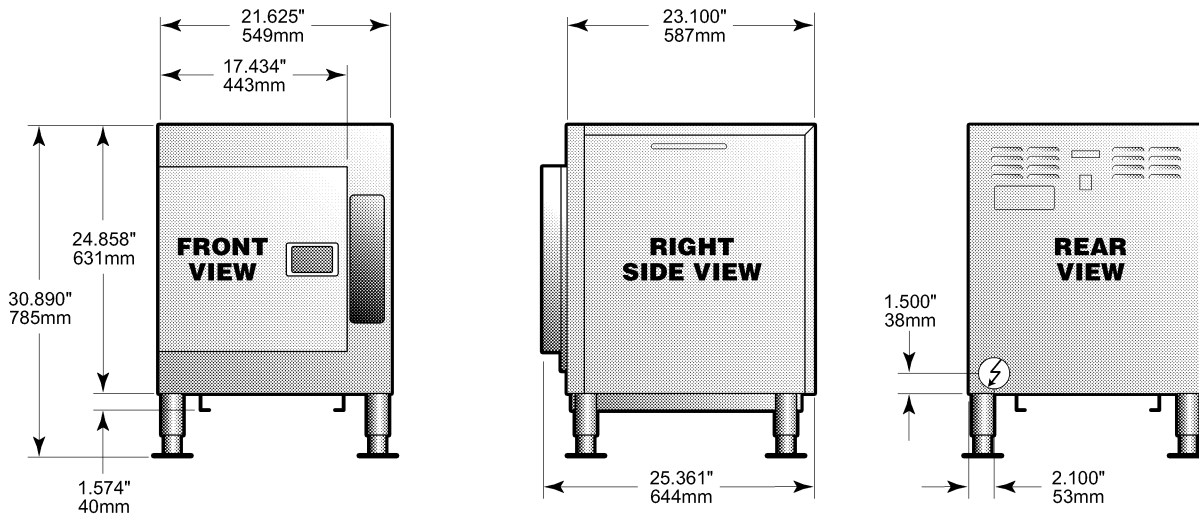

ELECTRICAL ⚡

WATTS	VOLTS	PHASE	WIRES	CYCLE HERTZ	AMPS	SUPPLY CONNECTION WIRE SIZE (COPPER)*	WATTS	VOLTS	PHASE	WIRES	CYCLE HERTZ	AMPS	SUPPLY CONNECTION WIRE SIZE (COPPER)*
Standard Wattage							Standard Wattage						
<i>Three Phase - 9 kW Standard</i>							<i>Single Phase - 9 kW Standard</i>						
9400	208	3	3	60	26.1	10	9400	208	1	2	60	45.2	6
9400	240	3	3	60	22.6	10	9400	240	1	2	60	39.2	8
9400	480	3	3	60	11.4	14							
Optional Low Wattage							Optional Low Wattage						
<i>Three Phase - 6 kW option</i>							<i>Single Phase - 6 kW option</i>						
6400	208	3	3	60	17.8	12	6400	208	1	2	60	30.8	8
6400	240	3	3	60	15.4	12	6400	240	1	2	60	26.7	10
6400	480	3	3	60	7.7	14							

* For supply connection use only copper wire suitable for at least 75°C. (167°F).

Note: Consult local authorities for venting and installation requirements.

* For supply connection use only copper wire suitable for at least 75°C (167°F).

NOTES:

Cleveland Range reserves right of design improvement or modification, as warranted. Many regional, state and local codes exist and it is the responsibility of the owner and installer to comply with the codes. Cleveland Range equipment is built to comply with applicable standards for manufacturers. Included among those approval agencies are U.L./NSF#4 and CSA (AGA, CGA).

CLEVELAND RANGE 1SCE
SEQUENCE OF OPERATIONS
STEAM CUB
Mechanical Timer

When using these instructions refer to the STEAM CUB wiring schematic.

1. Supply Voltage is sent to the primary of the power transformer.
 - 115 VAC is sent from the secondary of the power transformer to the on/off switch.
2. To turn the unit on, place the 115 VAC switch in the on position.
 - 115 VAC is sent to the H terminal of the water board.
 - 115 VAC is sent to the normally open contacts (R2B) of the R2 relay.
 - 115 VAC is sent to the normally open contacts (R1A) of the R1 relay.
 - 115 VAC is sent to the normally open contacts (R3B) of the R3 relay.
3. After water has been placed in the cooking cavity and the probe is grounded the water board will have 120 VAC at the heat terminal.
 - 115 VAC is sent through the normally closed contacts (R3A) of the R3 relay and the normally closed contacts (R2A) to the door switch.
 - If the water level drops below the probe the water board will remove 115 VAC from the HEAT terminal and send it to the FILL terminal.
 - From the FILL terminal 115 VAC is sent to the coil of the R3 relay.
 - The R3 relay energizes and the normally closed contacts (R3A) open.
 - The normally open contacts (R3B) will close and 115 VAC is sent to the ADD WATER light and buzzer.
4. With the door closed the door switch is closed and 115 VAC is sent to the timed/manual switch.
5. In the timed mode and time on the timer, or in the manual mode, 115 VAC is sent through the thermostat to the coil of the contactor.
 - The contactor closes and supply voltage is sent to the elements and the water is heated to steam.
 - When the cabinet reaches 205 degrees the thermostat opens and 115 VAC is removed from the coil of the contactor and the elements are de-energized.
 - When the unit cools the thermostat closes and the steamer heats again.
6. If one of the high limits (located on the heater blocks) opens a potential difference is placed across the coil of the R1 relay.
 - The R1 contacts will close energizing the R2 relay coil.
 - The normally open R2B contacts will close latching in the R2 coil.
 - The normally closed R2A contacts will open de-energizing the heater contactor.
 - The normally open R2A contacts will close energizing the buzzer.
 - The buzzer will sound until the unit is turned off.
7. To turn the unit of the rocker switch is depressed and the 115 VAC is removed from the heat circuit.

SteamCub MECHANICAL TIMER

ITEM PART No.

1	110198	12	108880	20	300701
2	20477	13	19993	HEAT BLOCK	
3	104224	14	300762	HEAT BLOCK	
4	107241	15	109157	HEAT BLOCK	
5	105966	16	12159	HEAT BLOCK	
6	03509	17	109374	21	208 300705 (10.7 KW)
7	20535	18	109380	-	220 300705 (12 KW)
8	109602	19	109617	-	240 300705 (14.3 KW)
9	109494	-	300156 *	-	480 300761 (12 KW)
10	441681	-	300156 *	-	480 300761 (12 KW)
11	109621	-	441681 *	-	440 300761 (10.1 KW)
					198°F

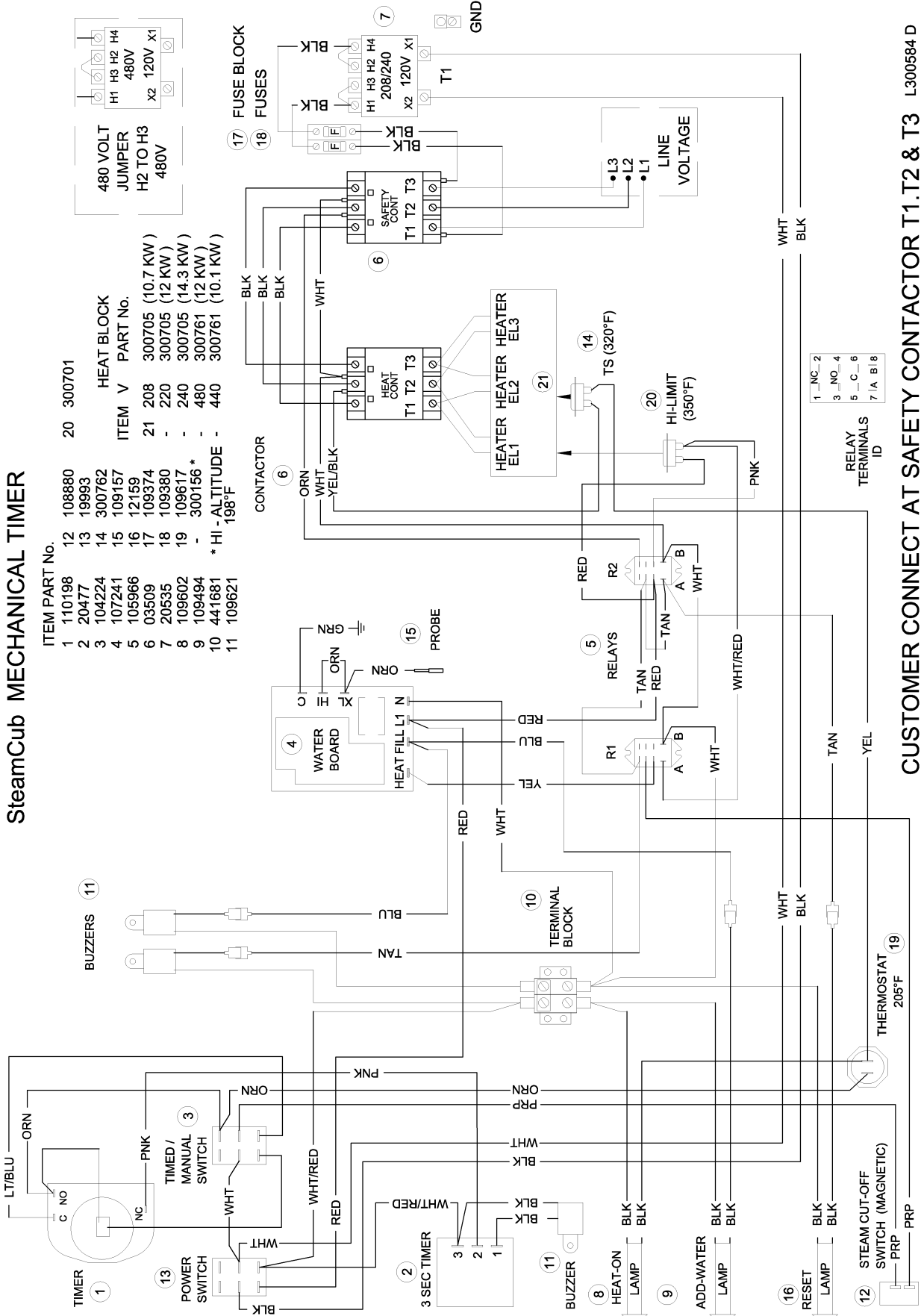
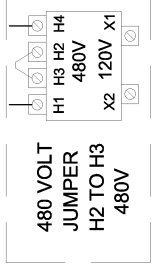

BUZZERS (11)

TIMER (1)

POWER SWITCH (13)

3 SEC TIMER (2)

BUZZER (11)

HEAT-ON LAMP (8)

ADD-WATER LAMP (9)

RESET LAMP (16)

STEAM CUT-OFF SWITCH (MAGNETIC) (12)

THERMOSTAT 205°F (19)

TERMINAL BLOCK (10)

PROBE (15)

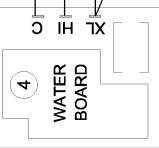

CONTACTOR (6)

HEAT CONT (6)

RELAYS (5)

TS (320°F) (14)

HI-LIMIT (350°F) (20)

1	_NC_2
3	_NO_4
5	_C_6
7	1A B 8

RELAY TERMINALS ID

CUSTOMER CONNECT AT SAFETY CONTACTOR T1, T2 & T3 L300584 D

SteamCub MECHANICAL TIMER

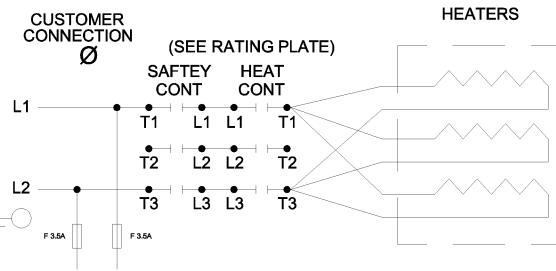
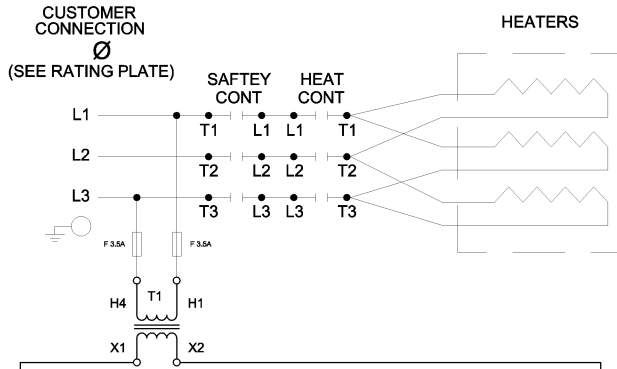

(SEE NOTE BELOW)

208/220/240V SINGLE PHASE UNITS
MUST USE 75 AMP. CONTACTORS
P/N 03506

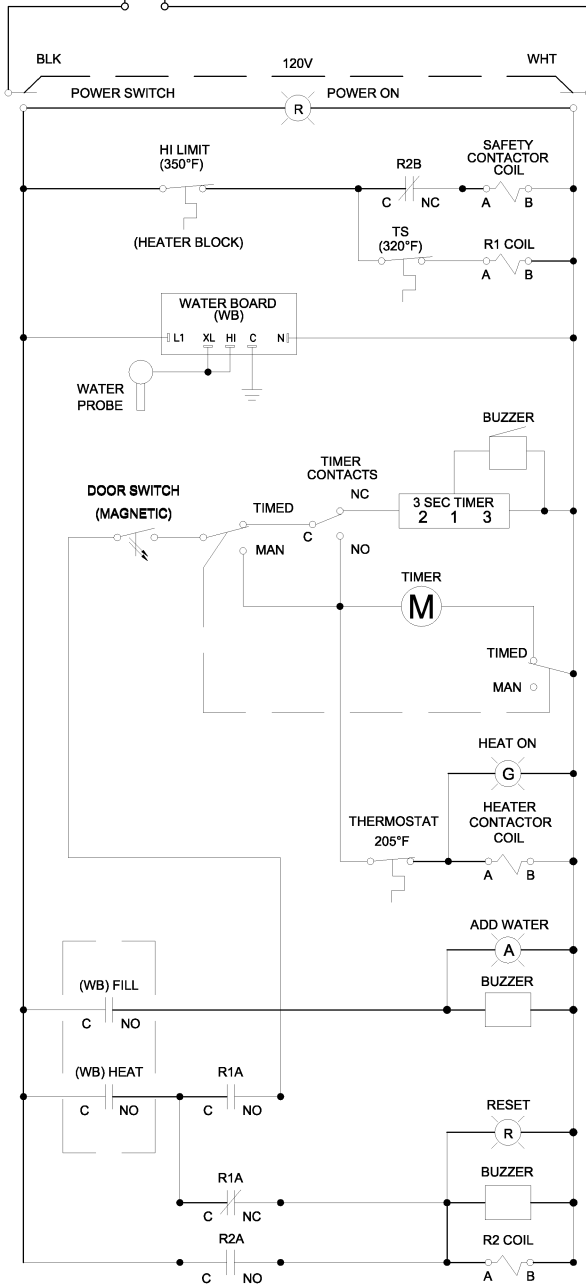

STEAMCUB™ BOILERLESS CONNECTIONLESS STEAMER

Project _____
 Item _____
 Quantity _____
 FCSI Section _____
 Approval _____
 Date _____

SteamCub™ Plus

PRESSURELESS STEAM COOKER,
RETHEMALIZER & HOLDING CABINET

MODEL: 1SCE

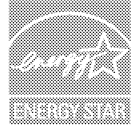

Cleveland Standard Features

- Boilerless Pressureless Steam Cooker, Holding Cabinet and Rethermalizer.
- Capacity: Full Size Steam Table Pans:
 - Five: 2 1/2" x 12" x 20" (1/1 GN, 65mm)
 - Ten: 1" x 12" x 20" (1/1GN, 40mm)
- Easy installation, no drain line or water connections are required.
- Programmable Preheat and Holding Cycle Temperature Controls with Compensating Thermostat.
 - Timer settings for 10 minute, 1 minute or 10 second intervals
 - Digital Time-Temperature and Low Water Indicator Display
- Three Versatile Operating Modes.
 - Steam and Hold
 - Holding Only: Preset at 160° F (71° C)
 - Constant Steaming
- 6" (152mm) Skid Resistant Stainless Steel Adjustable Legs with Flanged Feet.
- 8 gauge stainless steel inner cooking compartment, 14 gauge stainless steel outer compartment with two piece compartment door for an airtight, leak-proof seal.
- 9 kW total output, with easy to remove 1 kW heating elements (9ea) cast into aluminum blocks.
- Electronic Low-Water Shut-Off Safety Indicator with audible alarm, High Temperature Safety Shut-Off and LED "Heat On" Indicator Light.
- Separate Power ON/OFF Control includes an Automatic Pre-Heat when power is turned "ON".
- Easy-Access Manual Drain Valve located in front, Pan Slide Guides located under unit to fit 12" x 20" (1/1GN) Pans. Includes one 4" x 12" x 20
- Approvals: cUL, NSF #4.

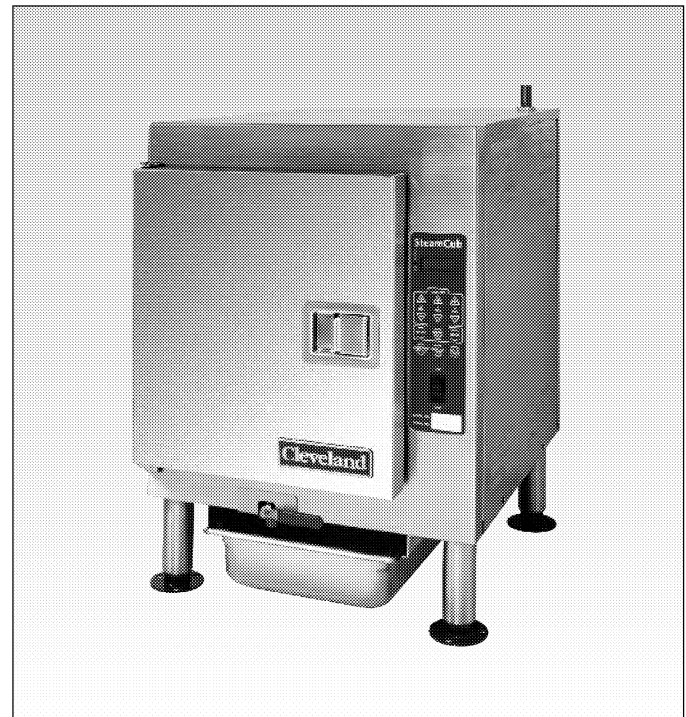

Short Form Specifications

Shall be a Cleveland SteamCub Plus™, Model 1SCE, one compartment counter top steamer, holding cabinet and rethermalizer model number 1SCE. Electronic controls with three operating modes: constants steaming, steam-hold and holding only. 9 kW, 208 volts, 3 phase. Audible low water and high temperature safety indicator. 8 gauge stainless steel inner cooking compartment, 14 gauge stainless steel outer compartment with two piece compartment door.

Options & Accessories

- Equipment Stand Model UniStand34.
- POSK Pull-Out Shelf Kit for UniStands (P/N 111724)
- URK Pan Rack Kit UniStands (P/N 111726)
- Optional Voltages, 480 Volt (VOS2).
- 6 kW total Output Six - 1kW heating elements.
- Single Phase Operation.

SECT. I PAGE 3
0109

WATER QUALITY REQUIREMENT

The recommended minimum water quality standards whether untreated or pre-treated, based upon 10 hours of use per day, and a Daily Blowdown, are as follows:

TOTAL DISSOLVED SOLIDS	less than 60 parts per million
TOTAL ALKALINITY	less than 20 parts per million
SILICA	less than 13 parts per million
pH FACTOR	greater than 7.5
CHLORINE	less than 30 parts per million

Consult a local water treatment specialist for an on site water analysis for recommendations concerning steam generator feed water treatment (if required), in order to remove or reduce harmful concentrations of minerals. The use of highly mineralized water will mean that more frequent servicing of the steam generator will be necessary. The fact that a water supply is potable is not proof that it will be suitable for the generator.

- Compartment has capacity for:
Five, 12" x 20" x 2½" deep Cafeteria Pans.

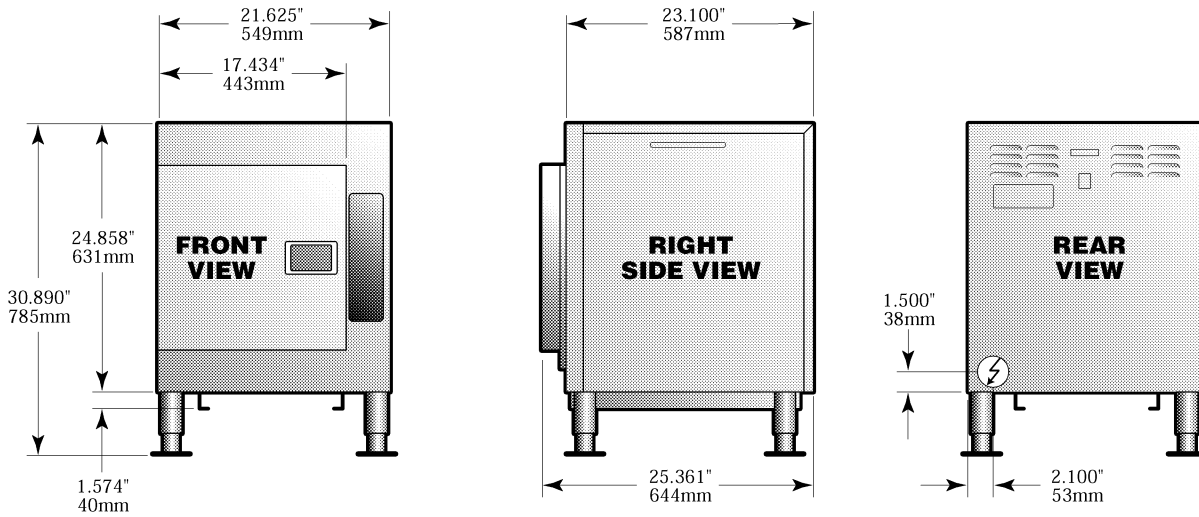

ELECTRICAL ⚡

WATTS	VOLTS	PHASE	WIRES	CYCLE HERTZ	AMPS	SUPPLY CONNECTION WIRE SIZE (COPPER)*	WATTS	VOLTS	PHASE	WIRES	CYCLE HERTZ	AMPS	SUPPLY CONNECTION WIRE SIZE (COPPER)*
Standard Wattage <i>Three Phase - 9 kW Standard</i>							Standard Wattage <i>Single Phase - 9 kW Standard</i>						
9400	208	3	3	60	26.1	10	9400	208	1	2	60	45.2	6
9400	240	3	3	60	22.6	10	9400	240	1	2	60	39.2	8
9400	480	3	3	60	11.4	14							
Optional Low Wattage <i>Three Phase - 6 kW option</i>							Optional Low Wattage <i>Single Phase - 6 kW option</i>						
6400	208	3	3	60	17.8	12	6400	208	1	2	60	30.8	8
6400	240	3	3	60	15.4	12	6400	240	1	2	60	26.7	10
6400	480	3	3	60	7.7	14							

* For supply connection use only copper wire suitable for at least 75°C. (167°F).

Note: Consult local authorities for venting and installation requirements.

* For supply connection use only copper wire suitable for at least 75°C (167°F).

NOTES:

Cleveland Range reserves right of design improvement or modification, as warranted. Many regional, state and local codes exist and it is the responsibility of the owner and installer to comply with the codes. Cleveland Range equipment is built to comply with applicable standards for manufacturers. Included among those approval agencies are U.L./NSF#4 and CSA (AGA, CGA).

(NOT TO SCALE)
SECT. I PAGE 4
0109
Litho in U.S.A.

CLEVELAND RANGE 1SCE
SEQUENCE OF OPERATIONS
STEAM CUB
Electronic Timer

When using these instructions refer to the STEAM CUB wiring schematic.

1. To turn the unit on, place the 115 VAC switch in the on position.
 - 115 VAC is sent to the H terminal of the water board.
 - 115 VAC is sent through the normally closed contacts (R2A) of the R2 relay to the primary of the 24 VAC transformer.
 - From the secondary of the 24VAC transformer 24 volts is sent to the programmable timer.
2. After water has been placed in the cooking cavity and the probe is grounded the water board will send 115 VAC to the door switch and the coil of R3 closing the normally open contacts to the programmable timer.
 - This tells the timer there is water allowing it to time down.
 - If the water level drops below the probe the water board will stop sending 115 VAC to the coil of R3. This will open the R3 contacts and the timer will display “add h2o”.
 - Without the minimum water level the water board will also prevent 115 VAC from getting to the door switch.
3. With the door closed the door switch is closed and 115 VAC is sent to the normally open contacts of the programmable timer.
 - When the programmable timer is calling for heat (the heat indicator light is energized) 115 VAC is sent to the coil of the heater contactor closing the contacts and energizing the elements.
4. If one of the high limits (located on the heater blocks) open a potential difference is placed across the coil of the R1 relay.
 - The R1 contacts will close energizing the R2 relay coil.
 - The normally open R2B contacts will close latching in the R2 coil.
 - The normally closed R2A contacts will open de-energizing the 24 VAC transformer.
 - The normally open R2A contacts will close energizing the buzzer.
 - The buzzer will sound until the unit is turned off.

SteamCub 6KW / 9KW (THREE PHASE)

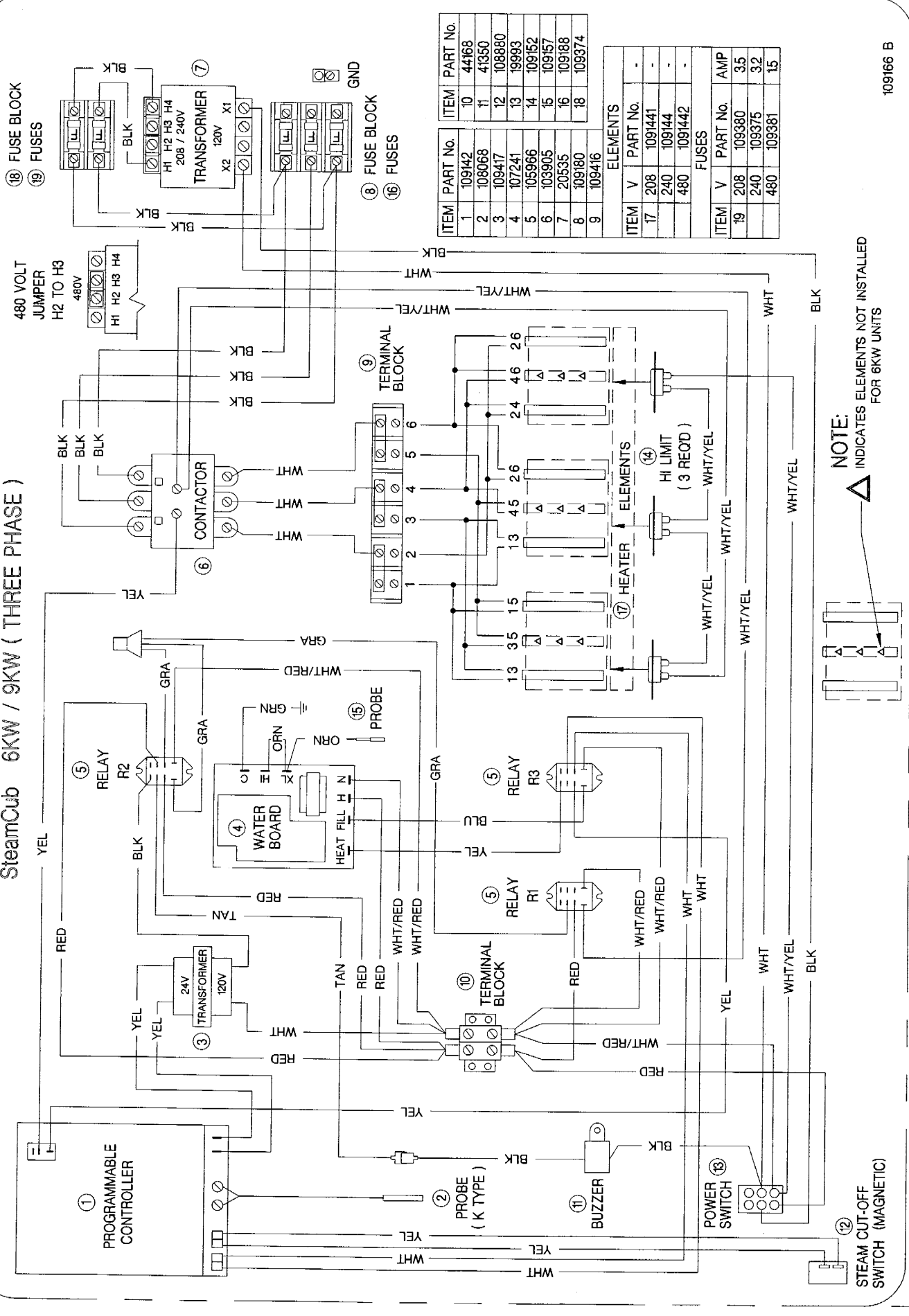

ITEM	PART No.	PART No.	ITEM	PART No.
1	109142	10	44168	
2	108068	11	41350	
3	109417	12	108880	
4	107241	13	19993	
5	105966	14	109152	
6	103905	15	109157	
7	20535	16	109188	
8	109180	18	109374	
9	109416			

ELEMENTS	
ITEM	V
17	208
	240
480	1091442

FUSES	
ITEM	V
19	208
	240
480	109381

NOTE: INDICATES ELEMENTS NOT INSTALLED FOR 6KW UNITS

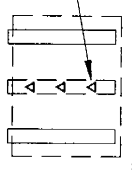

109166 B

0 TYP 4 PLCS

4.400

STEAMCUB 6KW / 9KW (THREE PHASE)

EL2-EL5-EL8 NOT PRESENT IN 6KW UNITS

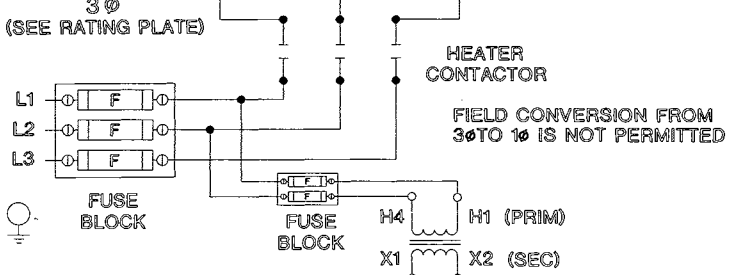
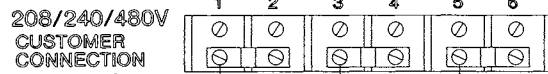
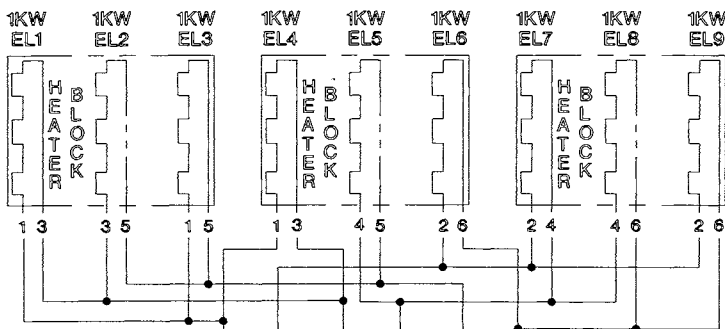

B1

B3

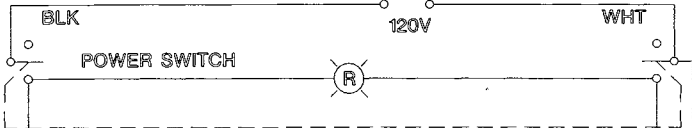

11.000

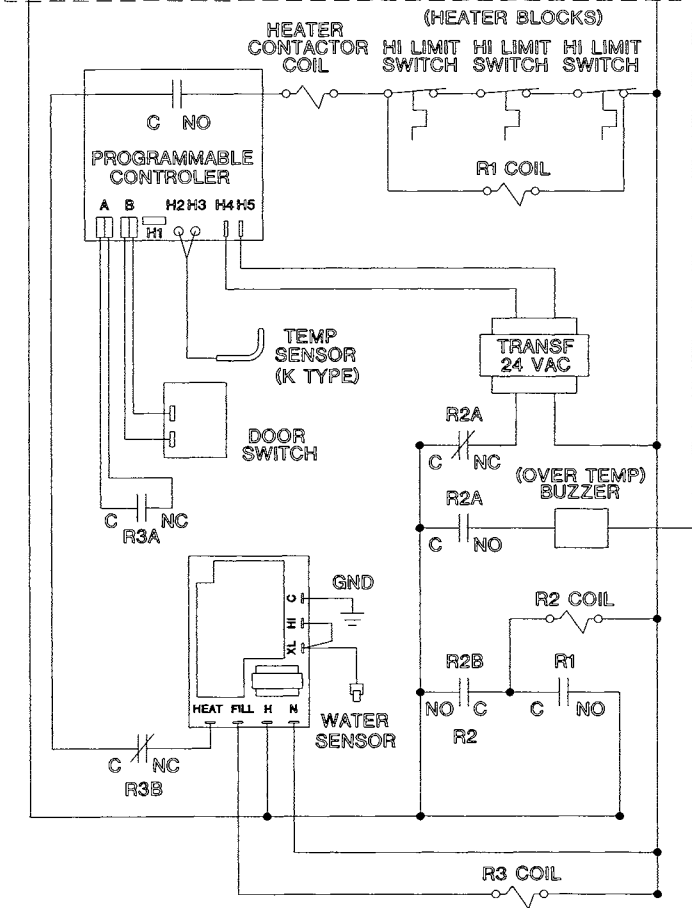

B2

109228 B

Re-Programming the Cooking-Preheat Temperature:

The “Preheat or “Cooking” temperature is preset at the factory for 205°F., 96°C. Changing the “Preheat and “Cooking temperature should be done by a qualified technician.

1. Pressing and holding the “DISPLAY TEMP” and “CONSTANT STEAM” buttons for 3 seconds will display a flashing cook temperature. Use the “TIME” setting increment and decrement buttons to set a new temperature. If there is no change for 5 seconds, the current input, if it is within range, it will disregard and the control will revert to its previous setting.

Re-Programming the Holding Temperature:

The “Holding” Temperature is preset at the factory for 160°F., 71°C. Changing the “Holding” temperature should be done by a qualified technician.

1. Pressing and holding the “DISPLAY TEMP” and “HOLD” buttons for 3 seconds will display a flashing cook temperature. Use the “TIME” setting increment and decrement buttons to set a new temperature. If there is no change for 5 seconds, the current input, if it is within range, it will disregard and the control will revert to its previous setting.

* NOTE: All Temperature settings are factory preset in degrees Fahrenheit. A jumper has been installed on the Temperature Control Board for degrees Celsius. A qualified Cleveland technician should change degrees F. to C.

SteamChef™ 3

Boilerless Convection Steamer,
Automatic Water Fill & Drain,
9 kW Boiler-Free Counter Type Design



MODEL: 22CET3.1



Cleveland Standard Features

- Cooking capacity for up to three 12" x 20" x 2.5" deep steam table pans (1/1 G/N, 65 mm).
- High-speed electric convection steamer with open style 1.5 gallon water reservoir located at the bottom of the cooking compartment for easy access and maintenance.
- Fan forced convection steam with patented **KleanShield™** cooking compartment design. **KleanShield™** collects and removes condensate waste from the cooking compartment. This keeps the compartment clean, safe from impurities and easy to maintain. Eliminates foaming and avoids contamination of the reservoir water.
- Automatic water level controls, fills when main power switch is turned ON, Low Water and High Water probes inside cooking compartment maintains water levels during cooking, eliminating the need to manually refill and monitor water level during cooking. Additional Safety Overflow Standpipe, 193° preheat and standby temperature. High Temperature Safety Shut-off.
- Steam and Fan Shut Off Control when compartment door is opened.
- 9 kW electric heating elements are in aluminum blocks for fast and ultra efficient heat transfer. Elements never need deliming because they are not immersed in water.
- Exclusive **SureCook** Compartment Controls improves cooking speed and accuracy. New energy saving design reduces water and electric usage. On-demand power control for faster heat up and recovery. Energy saving Standby Feature when not in use. The **SureCook** timer automatically adjusts the cooking time with the volume of product being cooked, eliminating guesswork on when the product is finished. Includes a 60-Minute Electro-Mechanical Timer, LED Indicator Lights for **SureCook** Cycle, Power On and Reset. Timed and Manual Bypass Switch for constant steaming.
- Exclusive **SteamChef™** Automatic Drain Control. Generator Drains when main power is turned OFF via 1/2" ball valve with micro switch circuitry. Simple 1 1/4" NPT drain connection required with water saving cold water condenser and 3 minute rinse feature.
- Left Hand Door Hinging: Compartment Doors hinged on the left, controls on the right.
- Exclusive, durable 14 gauge stainless steel compartment door and latch withstands abuse and heavy wear. Two piece compartment door with free floating inner door is self adjustable and prevents leaks. Reversible door gasket doubles the life of the gasket.
- Heavy-duty 4" (102mm) Skid Resistant Adjustable Legs with Flanged Feet.
- Meets agency codes: specifically UL and cUL listed, classified to NSF#4 and Energy Star.



Short Form Specifications

Shall be a Cleveland **SteamChef™ 3**, model 22CET3.1, one compartment high-speed electric convection steamer. ___ volt, ___ phase. Standard with **SureCook** Compartment Controls, 60-minute electro-mechanical timer with load compensating feature. Capacity for three 2.5" (1/1 G/N, 65 mm) full size steam table pans. 9kW electric heating elements in aluminum blocks. Includes 1/2" ball valve style automatic drain. Automatic water level controls. Heavy-duty 14 gauge stainless steel cooking compartment door and latch. **KleanShield™** clean cavity protection. 4" Adjustable Legs

Options & Accessories

- 34" (864mm) High Stainless Steel Economy Stand, for one 22CET3.1 (UniStand34)
- 24" (610mm) High Stainless Steel Stacking Stand (UniStand25), for mounting two stacked 22CET3.1, includes 2" Stainless Steel Mounting Spacer
- POSK Pull-Out Shelf Kit for UniStands (P/N 111724)
- URK Pan Rack Kit UniStands (P/N 111726)
- Right Hand Door Hinging, Controls on Left (DHR)
- ON/OFF Compartment control only, no timer (MC)
- 5 Foot (1524mm) FDA Approved National Hose Thread style water connection kit (garden hose thread), 2 required (NHT60)
- Single Point Water Connection (SPW)
- Single Phase Operation (see back)
- Optional Voltages, 480 Volt (VOS2), see back for alternative voltages.

- Each compartment has capacity for: Three, 12" x 20" x 2 1/2" deep Cafeteria Pans.
- Each compartment has capacity for: Six, 12" x 20" x 1" deep Cafeteria Pans.
- Each compartment has capacity for: Two, 12" x 20" x 4" deep Cafeteria Pans.

COLD WATER

C-1: Feed water for reservoir, 35 Psi Minimum, 60 Psi Maximum.

C-2: Drain condenser water, 35 Psi Minimum, 60 Psi Maximum.

Two 3/4" NH-F (Garden Thread) connections. Use NSF approved hose.

DRAIN CONNECTION

1 1/4" NPT-M

Do not connect other units to this drain.

Drain line must be vented. Vented drain connection included.

Do not connect drain to PVC pipe.

OPERATING CLEARANCES

3" Left, 3" Right and 4" Rear.

SERVICE CLEARANCES

12" on control side. Contact factory for variances to clearances.

CONTROLS

SureCook 60-minute electro mechanical timer with load compensating feature.

Three function control switch for Timed Cooking and Continuous Steaming.

APPROVALS

UL and cUL listed, classified to NSF#4 and Energy Star

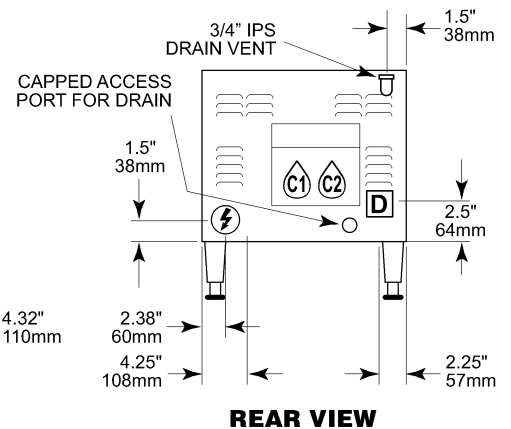
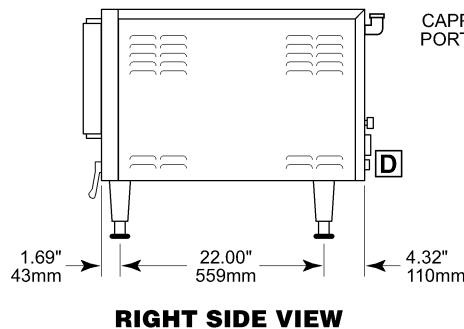
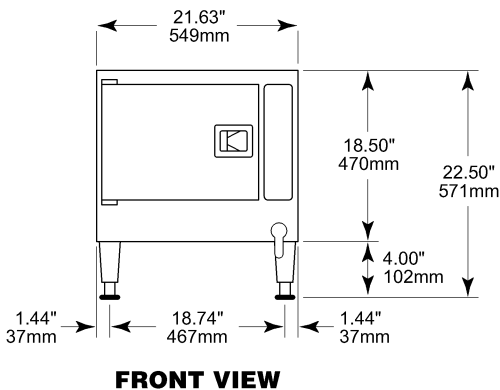
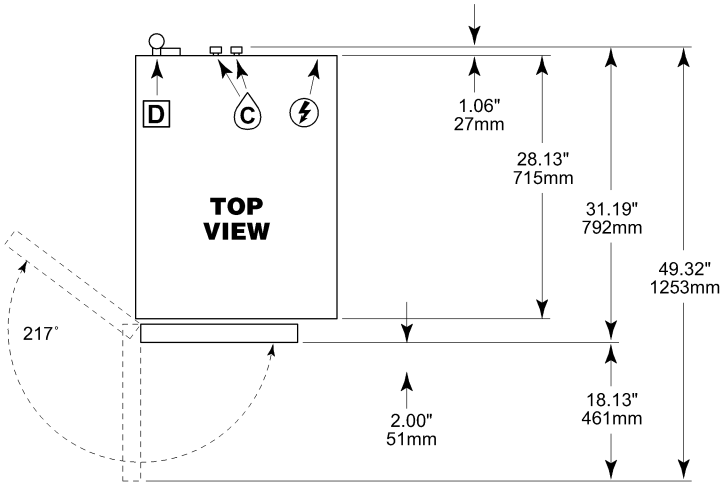

ELECTRICAL (Contact factory if installed above 3,500 feet)

WATTS	VOLTS	PHASE	WIRES	CYCLE HERTZ	AMPS	SUPPLY CONNECTION WIRE SIZE (COPPER)*
Standard Wattage						
<i>Three Phase - 9 kW Standard</i>						
9400	208	3	3	60	26.1	10
7960	220	3	3	60	20.9	10
9400	240	3	3	60	22.6	10
7960	440	3	3	60	10.4	14
9400	480	3	3	60	11.4	14
Optional Low Wattage						
<i>Three Phase - 6 kW option</i>						
6400	208	3	3	60	17.8	10
5440	220	3	3	60	14.3	12
6400	240	3	3	60	15.4	12
5440	440	3	3	60	7.1	14
6400	480	3	3	60	7.7	14

WATTS	VOLTS	PHASE	WIRES	CYCLE HERTZ	AMPS	SUPPLY CONNECTION WIRE SIZE (COPPER)*
Standard Wattage						
<i>Single Phase - 9 kW Standard</i>						
9400	208	1	2	60	45.2	6
7960	220	1	2	60	36.1	8
9400	240	1	2	60	39.2	8
7960	440	1	2	60	18.0	10
9400	480	1	2	60	19.6	10
Optional Low Wattage						
<i>Single Phase - 6 kW option</i>						
6400	208	1	2	60	30.8	8
5440	220	1	2	60	25.0	8
6400	240	1	2	60	26.7	8
5440	440	1	2	60	12.4	12
6400	480	1	2	60	13.3	12

* For supply connection use only copper wire suitable for at least 75°C. (167°F).

NOTES:

Cleveland Range reserves right of design improvement or modification, as warranted. Many regional, state and local codes exist and it is the responsibility of the owner and installer to comply with the codes. Cleveland Range equipment is built to comply with applicable standards for manufacturers. Included among those approval agencies are U.L./NSF#4 and CSA (AGA, CGA).

(NOT TO SCALE)
SECT. **B** PAGE **2**
0609
Litho in U.S.A.

SteamChef™ 6

Boilerless Convection Steamer,
Automatic Water Fill & Drain,
13.5 kW Boiler-Free Counter Type Design



MODEL: 22CET6.1



Cleveland Standard Features

- Cooking capacity for up to six 12" x 20" x 2.5" deep steam table pans (1/1 G/N, 65 mm).
- High-speed electric convection steamer with open style 1.5 gallon water reservoir located at the bottom of the cooking compartment for easy access and maintenance.
- Fan forced convection steam with patented **KleanShield™** cooking compartment design. **KleanShield™** collects and removes condensate waste from the cooking compartment. This keeps the compartment clean, safe from impurities and easy to maintain. Eliminates foaming and avoids contamination of the reservoir water.
- Automatic water level controls, fills when main power switch is turned ON, Low Water and High Water probes inside cooking compartment maintains water levels during cooking, eliminating the need to manually refill and monitor water level during cooking. Additional Safety Overflow Standpipe. 193° preheat and standby temperature. High Temperature Safety Shut-off.
- Steam and Fan Shut Off Control when compartment door is opened.
- 13.5 kW electric heating elements are in aluminum blocks for fast and ultra efficient heat transfer. Elements never need deliming because they are not immersed in water.
- Exclusive **SureCook** Compartment Controls improves cooking speed and accuracy. New energy saving design reduces water and electric usage. On-demand power control for faster heat up and recovery. Energy saving Standby Feature when not in use. The **SureCook** timer automatically adjusts the cooking time with the volume of product being cooked, eliminating guesswork on when the product is finished. Includes a 60-Minute Electro-Mechanical Timer, LED Indicator Lights for **SureCook** Cycle, Power On and Reset. Timed and Manual Bypass Switch for constant steaming.
- Exclusive **SteamChef™** Automatic Drain Control. Generator Drains when main power is turned OFF via 1/2" ball valve with micro switch circuitry. Simple 1 1/4" NPT drain connection required with water saving cold water condenser and 3 minute rinse feature.
- Left Hand Door Hinging: Compartment Doors hinged on the left, controls on the right.
- Exclusive, durable 14 gauge stainless steel compartment door and latch withstands abuse and heavy wear. Two piece compartment door with free floating inner door is self adjustable and prevents leaks. Reversible door gasket doubles the life of the gasket.
- Heavy-duty 4" (102mm) Skid Resistant Adjustable Legs with Flanged Feet.
- Meets agency codes: specifically UL and cUL listed, classified to NSF#4 and Energy Star.



Short Form Specifications

Shall be a Cleveland **SteamChef™ 6**, model 22CET6.1, one compartment high-speed electric convection steamer. ___ volt, ___ phase. Standard with **SureCook** Compartment Controls, 60-minute electro-mechanical timer with load compensating feature. Capacity for six 2.5" (1/1 G/N, 65 mm) full size steam table pans. 13.5 kW electric heating elements in aluminum blocks. Includes 1/2" ball valve style automatic drain. Automatic water level controls. Heavy-duty 14 gauge stainless steel cooking compartment door and latch. **KleanShield™** clean cavity protection. 4" Adjustable Legs

Options & Accessories

- 34" (864mm) High Stainless Steel Economy Stand, for one 22CET6.1 (UniStand34)
- 44" (1118mm) High Stainless Steel Stacking Stand (ES263044), for mounting two stacked 22CET6.1
- Right Hand Door Hinging, controls on right (DHR)
- ON/OFF Compartment control only, no timer (MC)
- 5 Foot (1524mm) FDA Approved National Hose Thread style water connection kit (garden hose thread), 2 required (NHT60)
- Single Point Water Connection (SPW)
- Optional Voltages, 480 Volt (VOS2), see back for alternative voltages.

SECT. B PAGE 3
0609

- Each compartment has capacity for: Six, 12" x 20" x 212" deep Cafeteria Pans.
- Each compartment has capacity for: Twelve, 12" x 20" x 1" deep Cafeteria Pans.
- Each compartment has capacity for: Four, 12" x 20" x 4" deep Cafeteria Pans.

COLD WATER

C-1: Feed water for reservoir, 35 Psi Minimum, 60 Psi Maximum.

C-2: Drain condenser water, 35 Psi Minimum, 60 Psi Maximum.

Two 3/4" NH-F (Garden Thread) connections. Use NSF approved hose.

DRAIN CONNECTION

1 1/4" NPT-M

Do not connect other units to this drain.

Drain line must be vented. Vented drain connection included.

Do not connect drain to PVC pipe.

OPERATING CLEARANCES

3" Left, 3" Right and 4" Rear.

SERVICE CLEARANCES

12" on control side. Contact factory for variances to clearances.

CONTROLS

SureCook 60-minute electro mechanical timer with load compensating feature.

Three function control switch for Timed Cooking and Continuous Steaming.

APPROVALS

UL and cUL listed, classified to NSF#4 and Energy Star

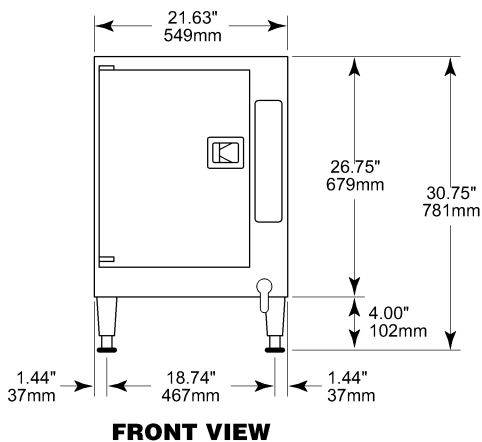
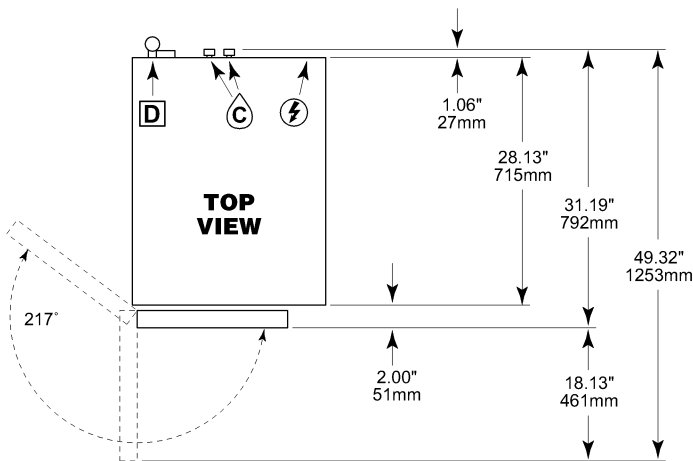

FRONT VIEW

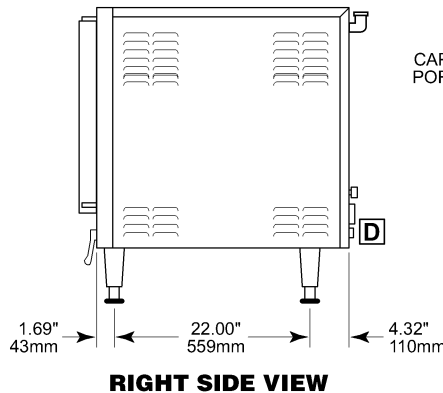

RIGHT SIDE VIEW

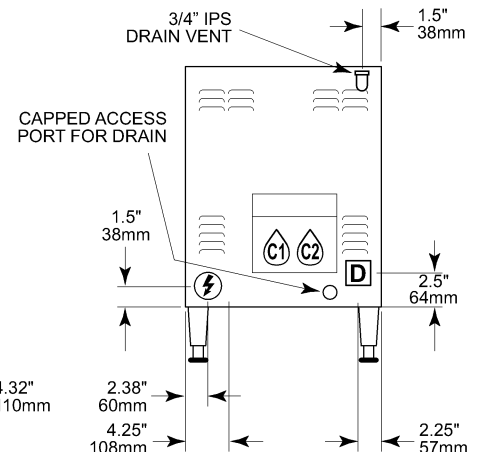

REAR VIEW

ELECTRICAL ⚡ (Contact factory if installed above 3,500 feet)

WATTS	VOLTS	PHASE	WIRES	CYCLE HERTZ	AMPS	SUPPLY CONNECTION WIRE SIZE (COPPER)*
-------	-------	-------	-------	-------------	------	---------------------------------------

Standard Wattage

Three Phase - 13.5 kW Standard

13500	208	3	3	60	37.5	6
11300	220	3	3	60	29.7	8
13500	240	3	3	60	32.5	8
11300	440	3	3	60	14.9	12
13500	480	3	3	60	16.2	10

Optional Low Wattage

Three Phase - 9 kW option

9400	208	3	3	60	26.1	8
5440	220	3	3	60	20.9	10
9400	240	3	3	60	22.6	10
5440	440	3	3	60	10.4	14
9400	480	3	3	60	11.4	14

* For supply connection use only copper wire suitable for at least 75°C. (167°F).

WATTS	VOLTS	PHASE	WIRES	CYCLE HERTZ	AMPS	SUPPLY CONNECTION WIRE SIZE (COPPER)*
-------	-------	-------	-------	-------------	------	---------------------------------------

Standard Wattage

Single Phase - 13.5 kW Standard

13500	208	1	2	60	64.9	4
11300	220	1	2	60	51.4	6
13500	240	1	2	60	56.3	4
11300	440	1	2	60	25.8	8
13500	480	1	2	60	28.1	8

Optional Low Wattage

Single Phase - 9 kW option

9400	208	1	2	60	45.2	6
5440	220	1	2	60	36.1	8
9400	240	1	2	60	39.2	8
5440	440	1	2	60	18.0	10
9400	480	1	2	60	19.6	10

NOTES:

Cleveland Range reserves right of design improvement or modification, as warranted.

Many regional, state and local codes exist and it is the responsibility of the owner and installer to comply with the codes.

Cleveland Range equipment is built to comply with applicable standards for manufacturers. Included among those approval agencies are U.L./NSF#4 and CSA (AGA, CGA).

(NOT TO SCALE)

SECT. B PAGE 4

0609

Litho in U.S.A.

208/240/480V
CUSTOMER
CONNECTION
3 Ø
(SEE RATING PLATE)

STEAMCHEF 3.1/6.1 MECH TIMER (THREE PHASE)

208/240/480V
CUSTOMER
CONNECTION
1 Ø
(SEE RATING PLATE)

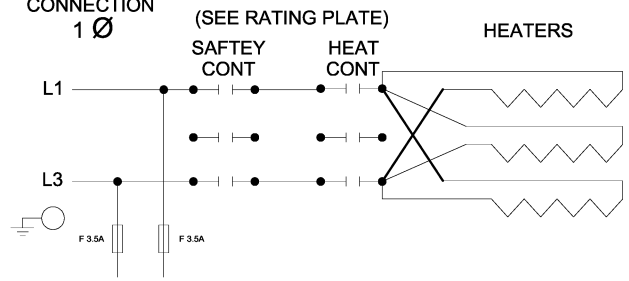
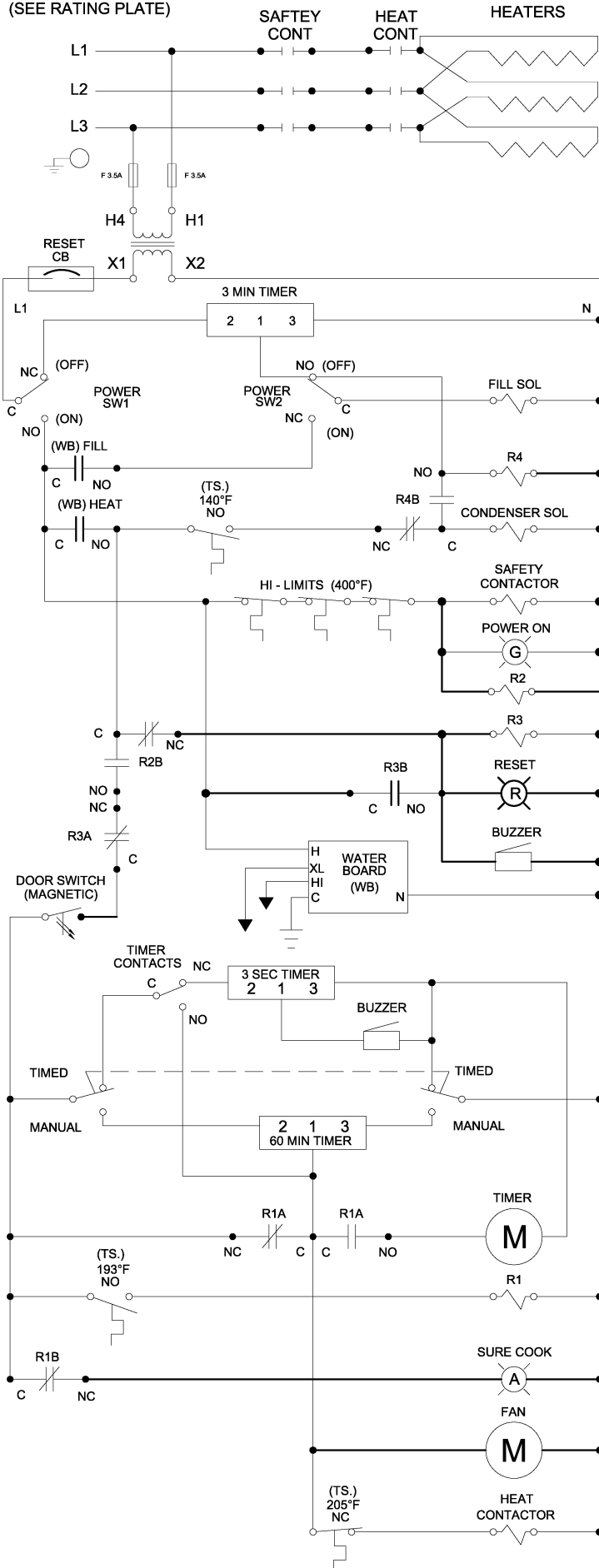

ITEM PART No.

- 1 110198
- 2 300150
- 3 19972
- 4 107241
- 5 105966
- 6 03509
- 7 300254
- 8 109617
- 9 20477
- 10 44168
- 11 41350
- 12 108880
- 13 109602
- 14 109152
- 15 3003231
- 16 106288
- 17 300255
- 18 109374
- 19 109380
- 20 109494
- 21 12159
- 22 104224
- 23 22218
- 24 110613
- 25 110683
- 26 20478

HEAT BLOCKS

ITEM	V	PART No.
208		300186 - 3KW
240		3001861 - 3KW
480		3001862 - 3KW
208		300185 - 2KW
240		3001851 - 2KW
480		3001852 - 2KW
6.1 ONLY (13.5KW)		
240		3003301 - 4.5KW
480		300330 - 4.5KW

3.5A 600V

240/480V
CUSTOMER
CONNECTION

STEAMCHEF 3.1 / 6.1 ON/OFF CONTROL

208/240/480V
CUSTOMER
CONNECTION

3 Ø
(SEE RATING PLATE)

(SEE RATING PLATE)

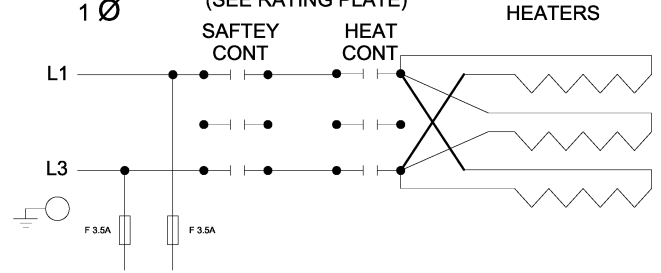
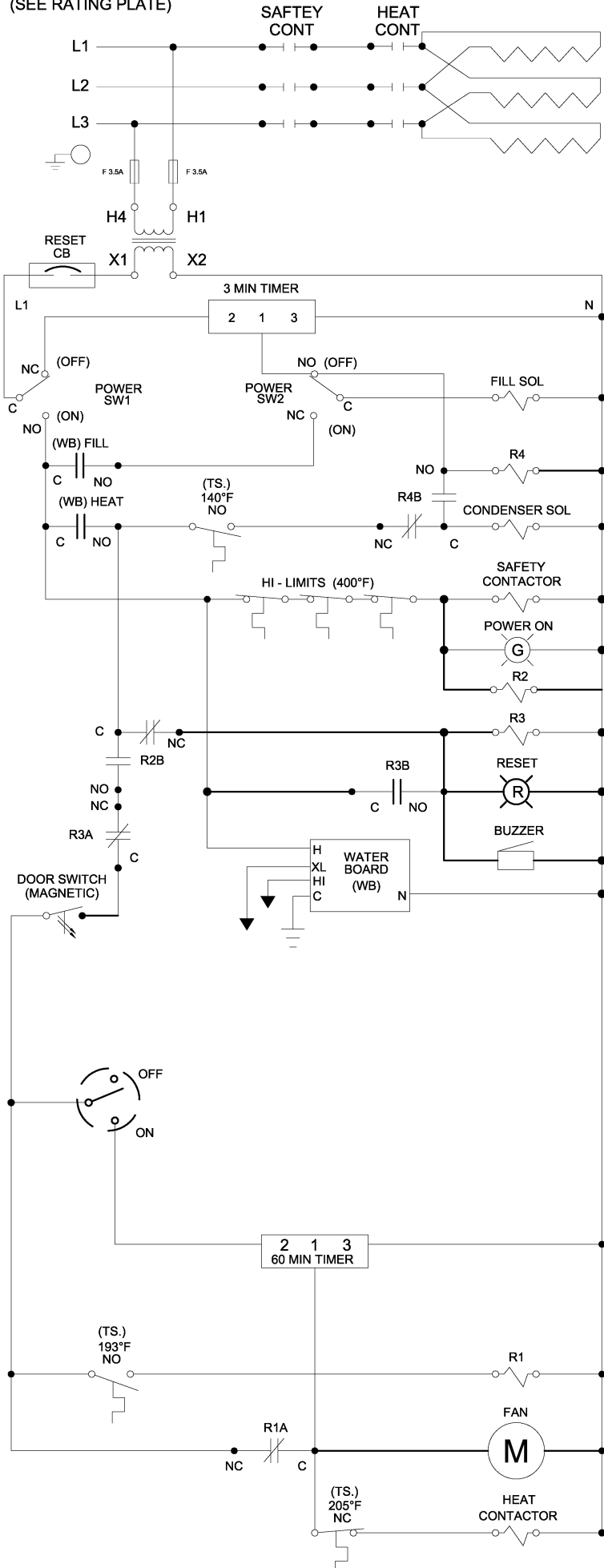

ITEM PART No.

- 1 102534
- 2 102533
- 3 19972
- 4 107241
- 5 105966
- 6 03509
- 7 300254
- 8 109617
- 9 300150
- 10 44168
- 11 41350
- 12 108880
- 13 20478
- 14 109152
- 15 3003231
- 16 106288
- 17 300255
- 18 109374
- 19 109380
- 20 109494
- 21 12159
- 22 110683
- 23 22218
- 24 110613

STEAMCHEF 3.1/6.1 ON / OFF CONTROL (THREE PHASE)

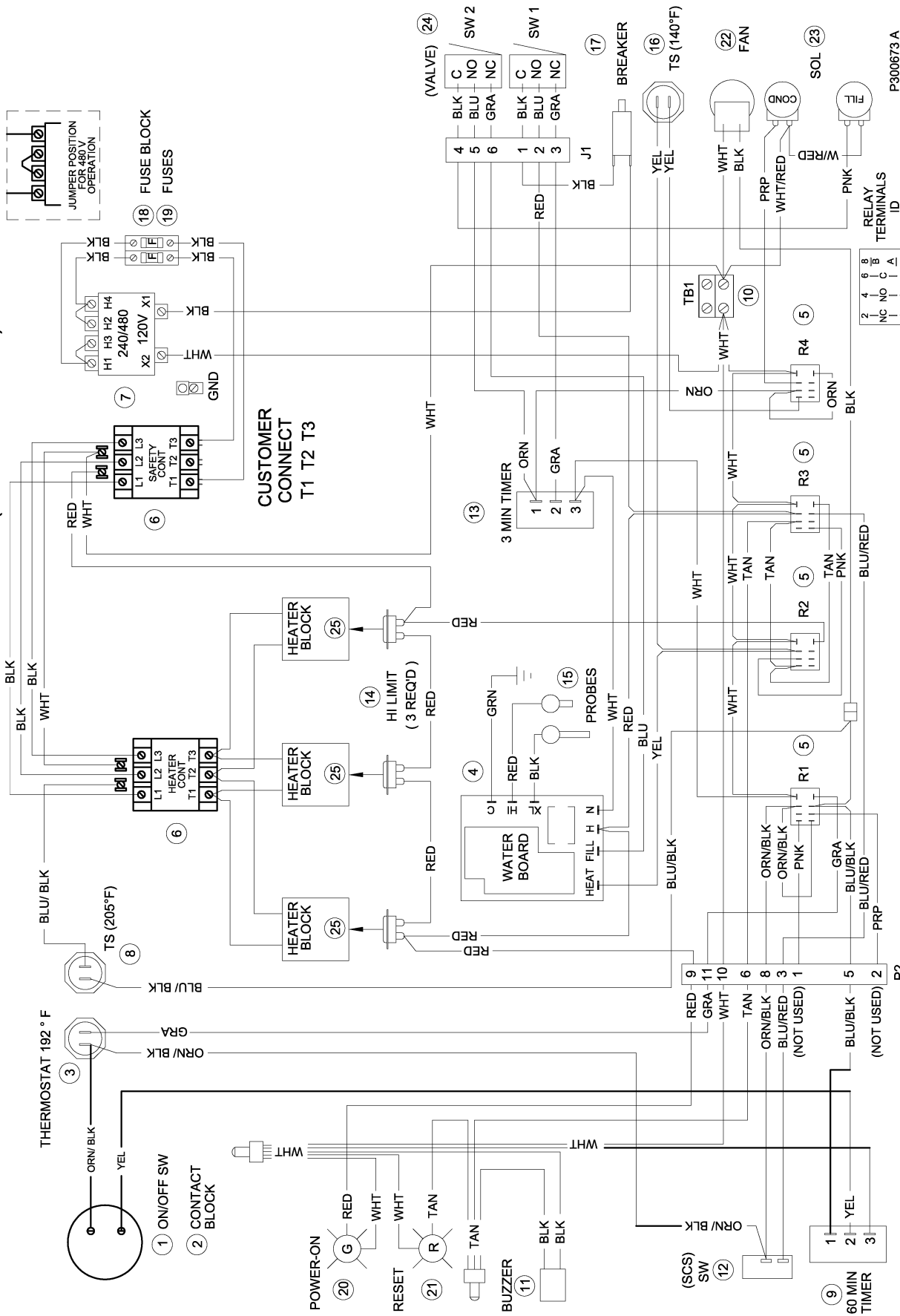

HEAT BLOCKS

- | ITEM | V | PART No. |
|-------------------|-----|-----------------|
| 25 | 208 | 300186 - 3KW |
| | 240 | 3001861 - 3KW |
| | 480 | 3001862 - 3KW |
| | 208 | 300185 - 2KW |
| | 240 | 3001851 - 2KW |
| | 480 | 3001852 - 2KW |
| 6.1 ONLY (13.5KW) | | |
| | 240 | 3003301 - 4.5KW |
| | 480 | 3003330 - 4.5KW |

STEAMCHEF 6.1 /3.1 MECH TIMER (THREE PHASE) **AFTER 5-2010**

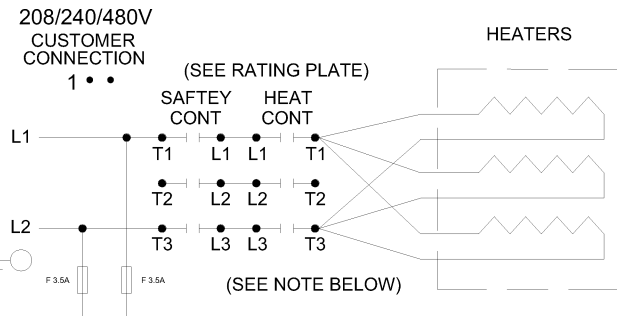
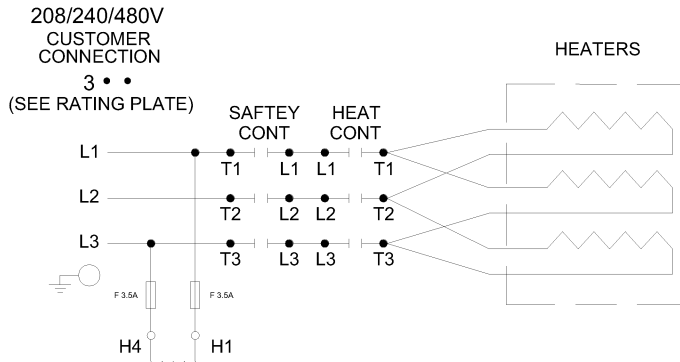

NOTE:
 (SINGLE PHASE)
 208V / 240V
 USE 75A. CONTACTORS
 P/N 03506

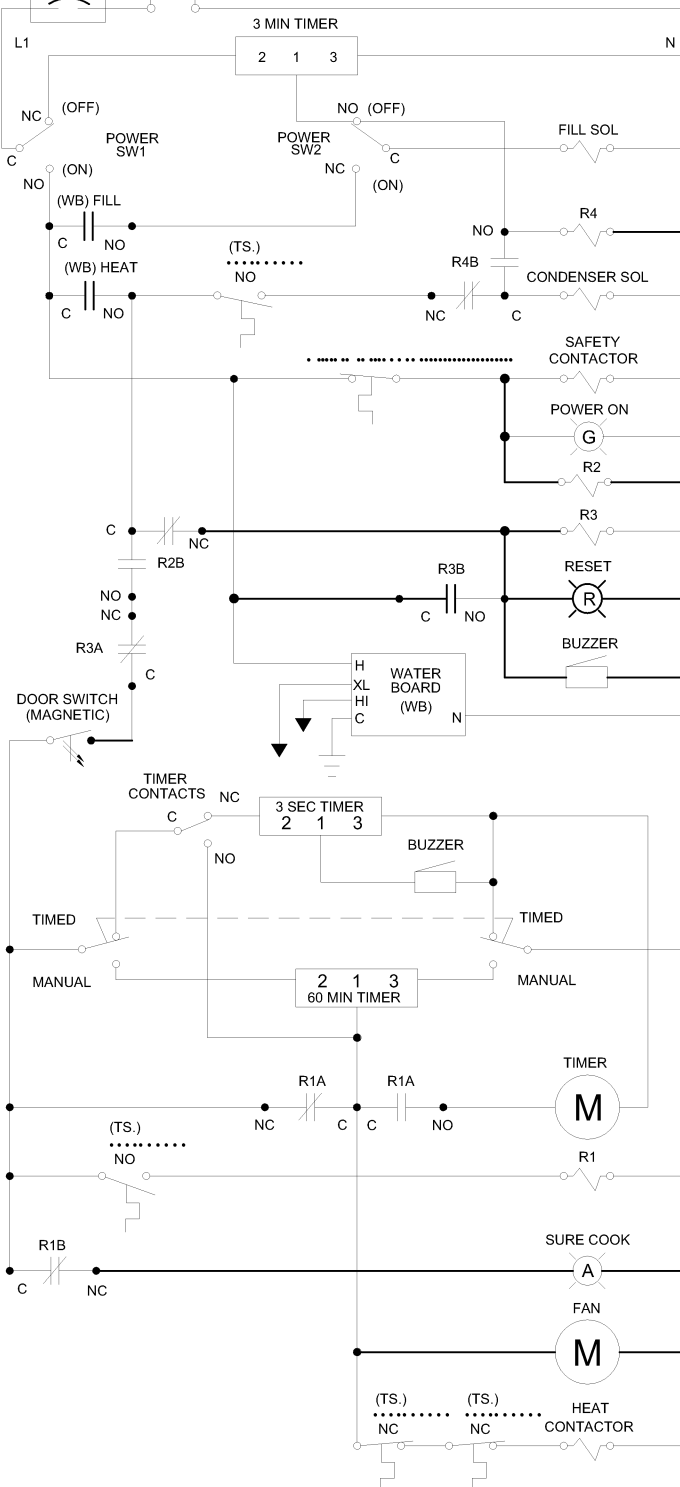

ITEM PART No.

- 1 110198
- 2 300150
- 3 300677
- 4 107241
- 5 105966
- 6 03509 (50 AMP)
- * 03506 (75 AMP SINGLE PHASE UNITS)
- 7 300254
- 8 109617
- * 300156
- 9 20477
- 10 44168
- 11 41350
- 12 108880
- 13 109602
- 14 300762
- 15 300688
- 16 106288
- 17 300255
- 18 109374
- 19 109380 3.5A 600V
- 20 109494
- 21 12159
- 22 104224
- 23 22218
- 24 110613
- 25 110683
- 26 20478
- 27 300750
- 28 300701

ITEM V PART No.

- 29 208 300705 (10.7 KW)
- 220 300705 (12 KW)
- 240 300705 (14.3 KW)
- 480 300761 (12 KW)

240/480V
CUSTOMER
CONNECTION

STEAMCHEF 3.1 / 6.1 ON/OFF CONTROL

BEFORE 5-2010

3 Ø
(SEE RATING PLATE)

208/240/480V
CUSTOMER
CONNECTION

(SEE RATING PLATE)

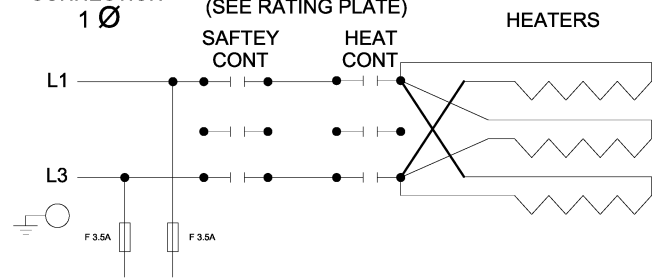
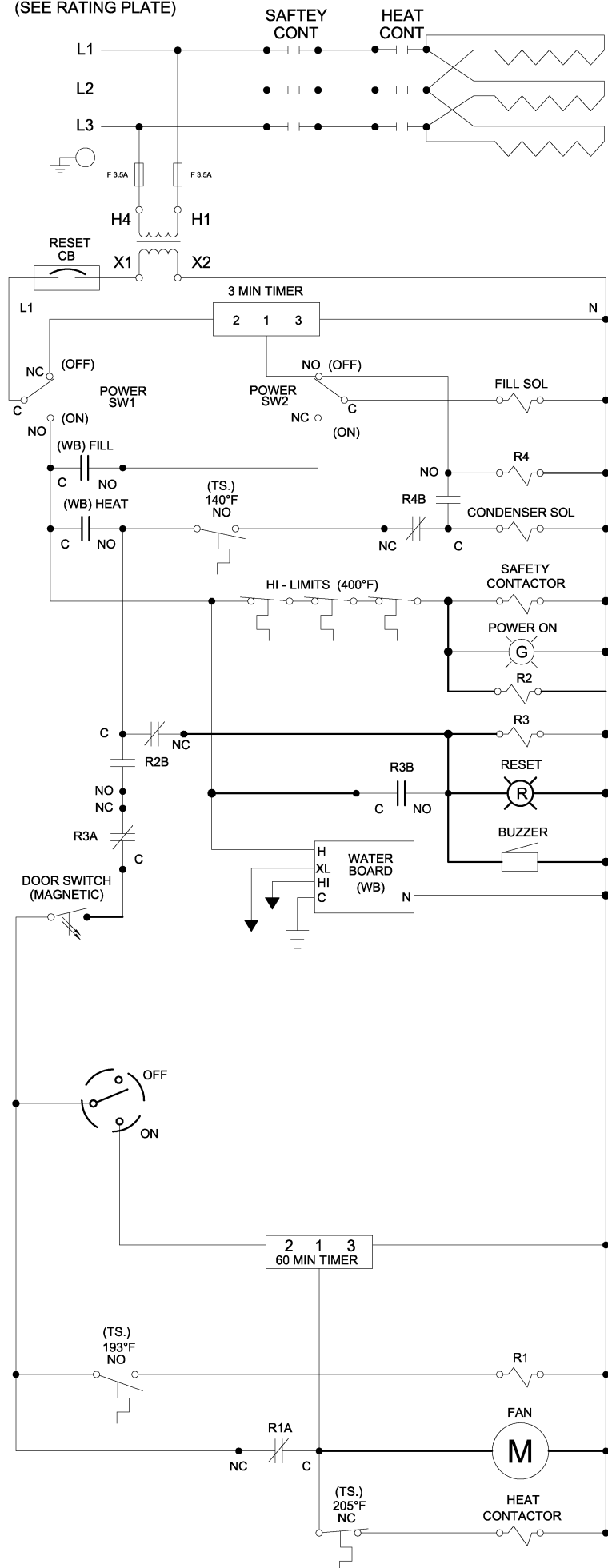

ITEM PART No.

- 1 102534
- 2 102553
- 3 19972
- 4 107241
- 5 105966
- 6 03509
- 7 300254
- 8 109617
- 9 300150
- 10 44168
- 11 41350
- 12 108880
- 13 20478
- 14 109152
- 15 3003231
- 16 106288
- 17 300255
- 18 109374
- 19 109380
- 20 109494
- 21 12159
- 22 110683
- 23 22218
- 24 110613

HEAT BLOCKS

- ITEM V PART No.
- 25 208 300186 - 3KW
- 240 3001861 - 3KW
- 480 3001862 - 3KW
- 208 300185 - 2KW
- 240 3001851 - 2KW
- 480 3001852 - 2KW

- 6.1 ONLY (13.5KW)
- 240 3003301 - 4.5KW
- 480 3003330 - 4.5KW

STEAMCHEF 3.1/6.1 ON / OFF CONTROL (THREE PHASE)

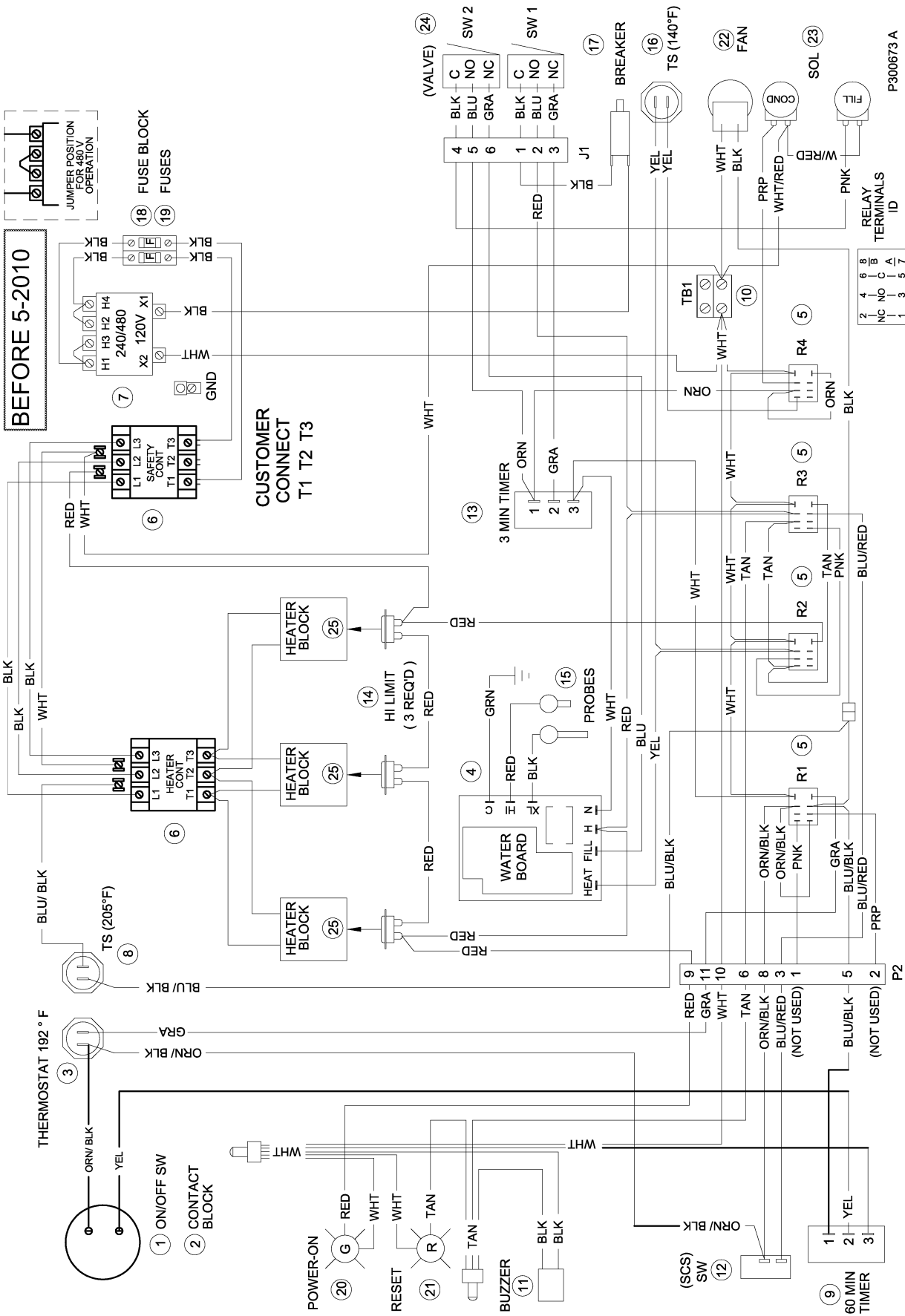

STEAMCHEF 3.1 / 6.1 ON/OFF CONTROL

AFTER 5-2010

208/240/480V
CUSTOMER
CONNECTION
3 • •
(SEE RATING PLATE)

208/240/480V
CUSTOMER
CONNECTION
1 • •

HEATERS

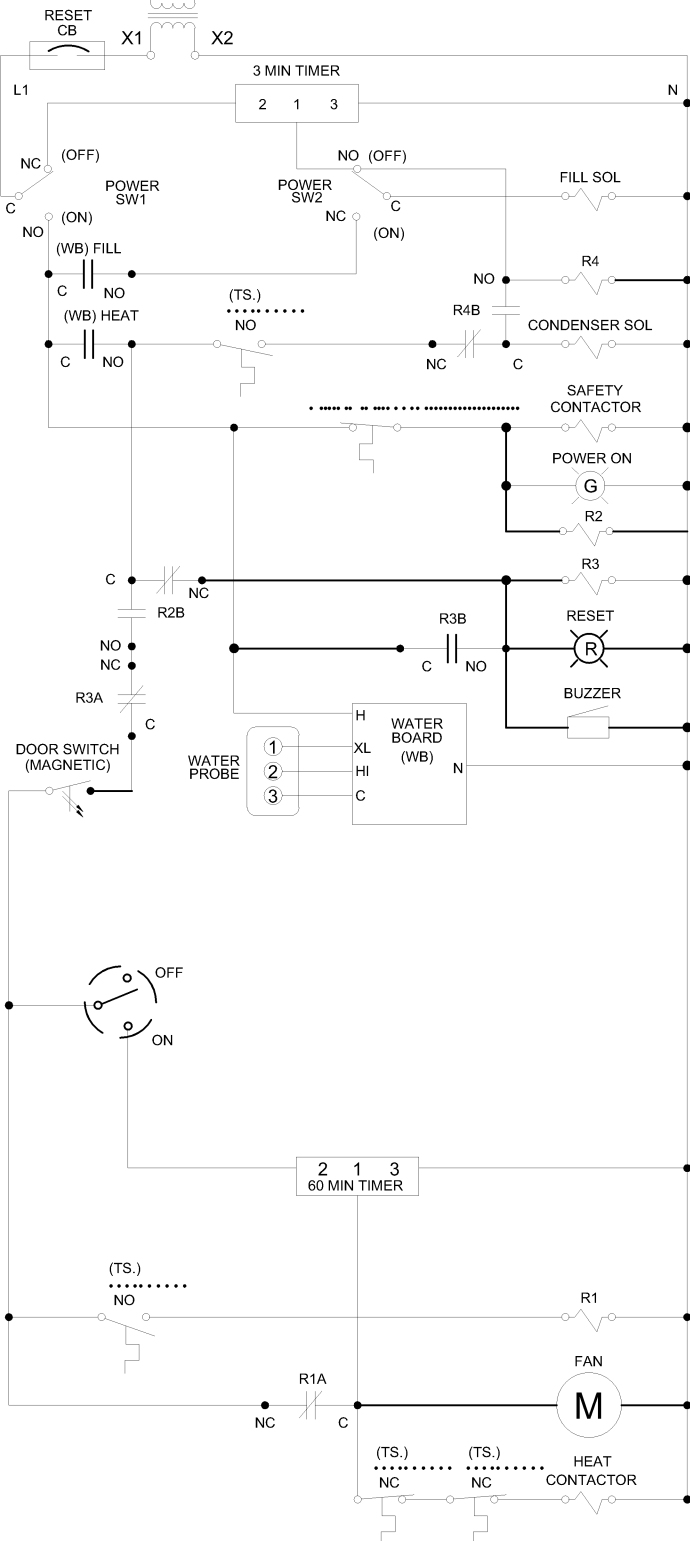
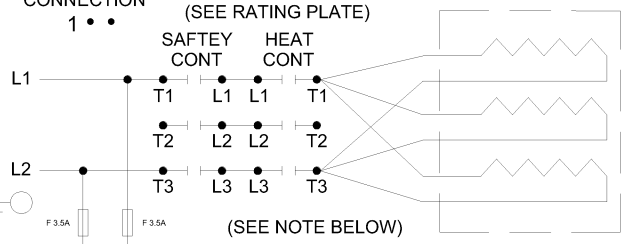
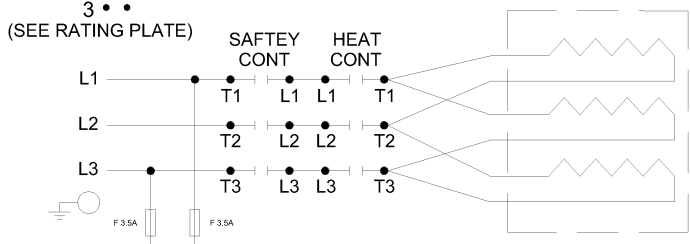

NOTE:

(SINGLE PHASE)
208V / 240V
USE 75A. CONTACTORS
P/N 03506

ITEM PART No.

- 1 102534
- 2 102533
- 3 300677
- 4 107241
- 5 105966
- 6 03509 (50 AMP)
- * 03506 (75 AMP SINGLE PHASE UNITS)
- 7 300254
- 8 109617
- * 300156
- 9 300150
- 10 44168
- 11 41350
- 12 108880
- 13 20478
- 14 300762
- 15 300688
- 16 106288
- 17 300255
- 18 109374
- 19 109380 3.5A 600V
- 20 109494
- 21 12159
- 22 110683
- 23 22218
- 24 110613
- 25 300750
- 26 300701

ITEM V PART No.

- 27 208 300705 (10.7 KW)
- 220 300705 (12 KW)
- 240 300705 (14.3 KW)
- 480 300761 (12 KW)

STEAMCHEF 6.1/3.1 ON / OFF CONTROL THREE PHASE (SINGLE PHASE SEE SHEET2)

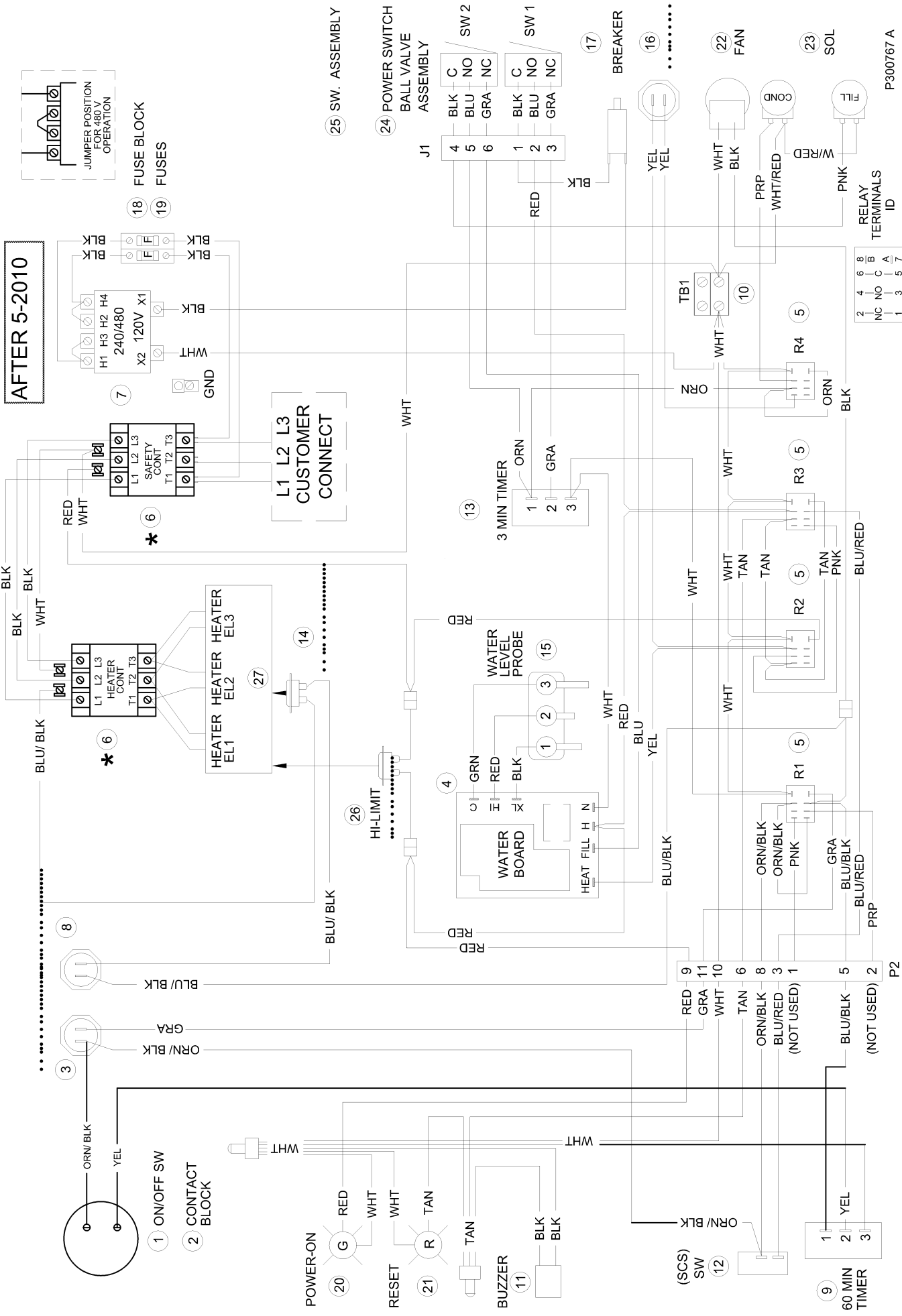

208/240/480V
CUSTOMER
CONNECTION

STEAMCHEF 3.1/6.1 ELECTRONIC TIMER (3 PHASE)

AFTER 5-2010

3 • •
(SEE RATING PLATE)

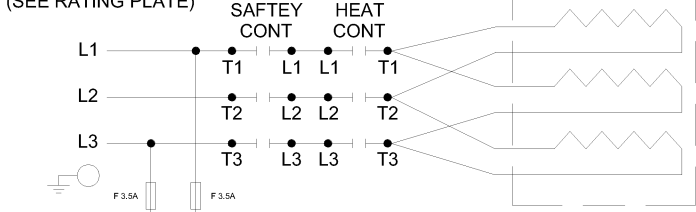

208/240/480V
CUSTOMER
CONNECTION

1 • •

(SEE RATING PLATE)

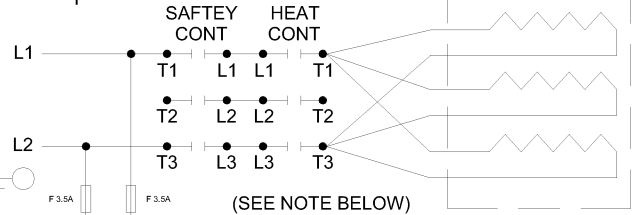

(SEE NOTE BELOW)

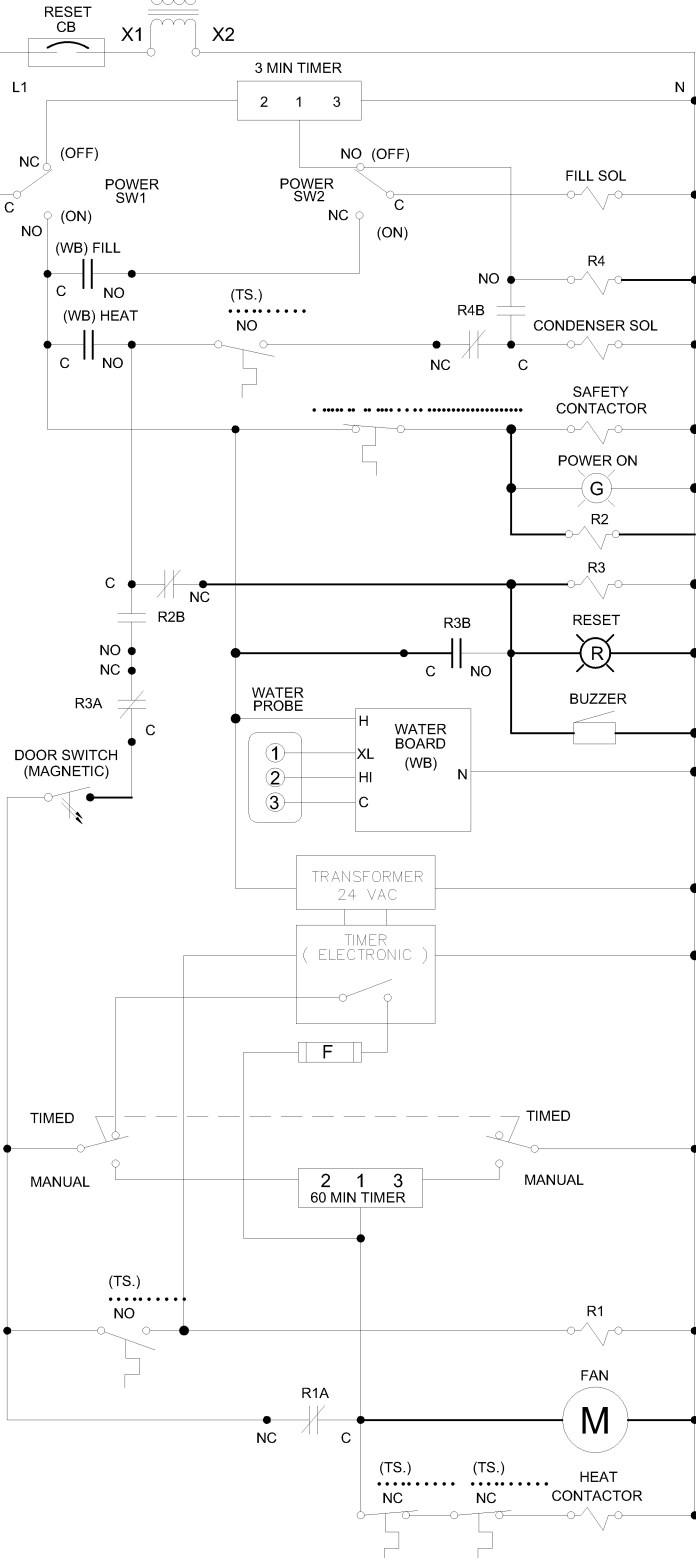

NOTE:

(SINGLE PHASE)
220V / 240V
USE 75A. CONTACTORS
P/N 03506

ITEM PART No.

- 1 104389
- 2 300150
- 3 300677
- 4 107241
- 5 105966
- 6 03509 (50 AMP)
- * 03506 (75 AMP SINGLE PHASE UNITS)
- 7 300254
- 8 109617
- * 300156
- 9 104390
- 10 44168
- 11 41350
- 12 108880
- 13 20478
- 14 300762
- 15 300688
- 16 106288
- 17 300255
- 18 109374 3.5A 600V
- 19 109380
- 20 106909
- 21 12159
- 22 104224
- 23 22218
- 24 110613
- 25 110683
- 26 300750
- 27 300701

ITEM V PART No.

- 28 208 300705 (10.7 KW)
- 220 300705 (12 KW)
- 240 300705 (14.3 KW)
- 480 300761 (12 KW)

STEAMCHEF 3.1 /6.1 ELECTRONIC TIMER THREE PHASE (SINGLE PHASE SEE SHEET 2)

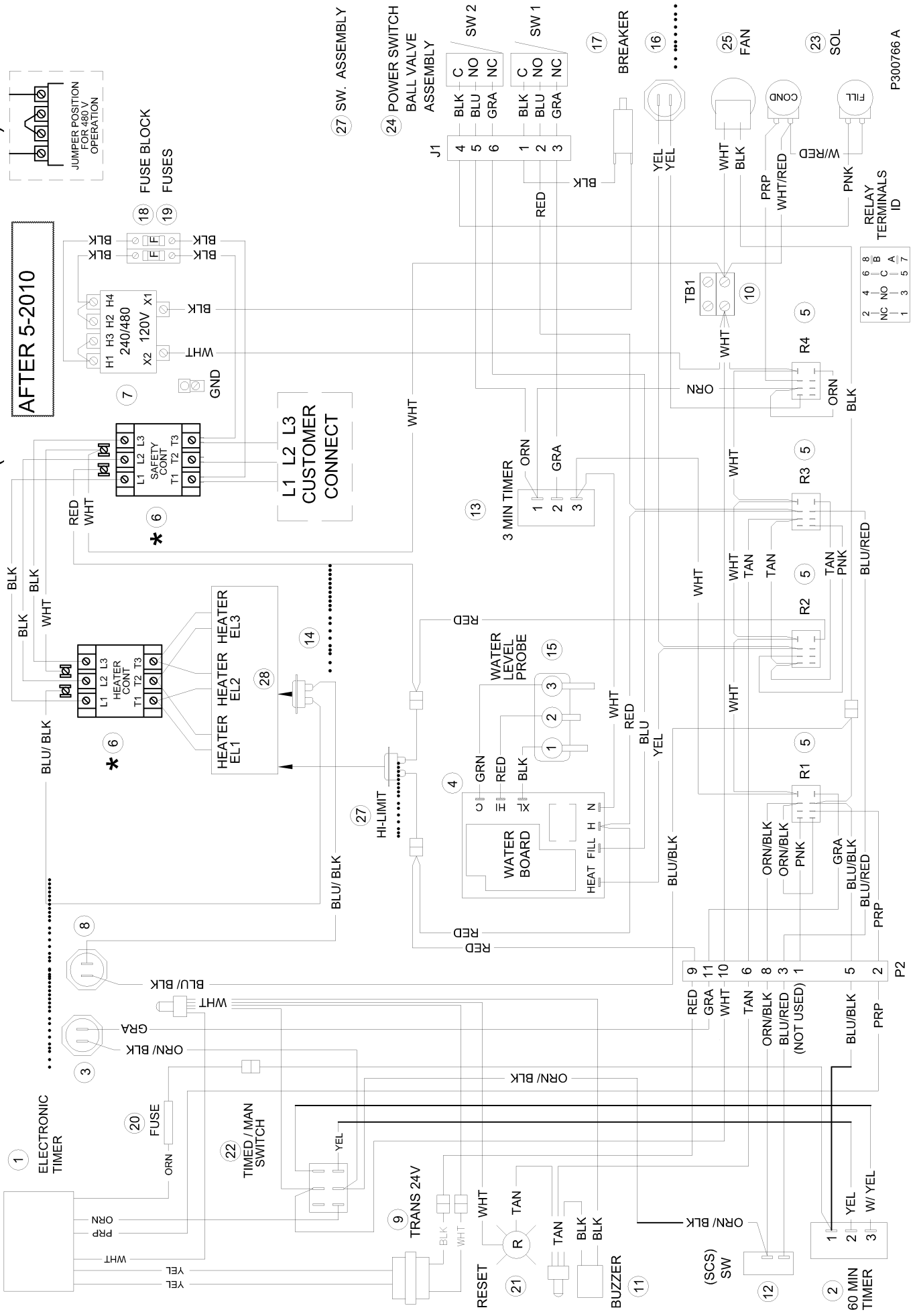

Replacement Procedure for Cast Heater Blocks SteamCub and SteamChef Steamers

Cleveland Range has developed the Replacement Procedure for Cast Heater Blocks in SteamCub and SteamChef Steamers for use by qualified Cleveland Range authorized service representatives.

For questions, please call the Cleveland Range Service Department at 216-481-4900 or 1-800-338-2204

Cast Heater Block Replacement Kits		
Part Number For Complete Kits	Heater Block Rating	Cast Heater Block P/N
FK3001852	480 V, 2000 W	3001852
FK3001851	240 V, 2000 W	3001851
FK300185	208 V, 2000 W	300185
FK3001862	480 V, 3000 W	3001862
FK3001861	240 V, 3000 W	3001861
FK300186	208 V, 3000 W	300186
FK300330	480 V, 4500 W	300330
FK3003301	240 V, 4500 W	3003301
FK3003302	208 V, 4500 W	3003302

All Kits Contain the Following:		
Part No.	Description	Quantity Ea.
N/A	Cast Heater Block. See above table for Part Numbers.	1
1091391	Thermal Joint Compound, 2 oz. Tube	1
112480	Washer, Belleville Spring, 1/4"	8
112481	Brass Hex Nut, 1/4 -20	8
112518	Loctite Threadlocker 290, 0.5 ml Tube	1

You Will Need:

Turpentine or Mineral Spirits
Solvent-Proof Gloves
Clean, Dry, Lint-Free Rags
Putty Knife, 4"

Latex Gloves
Torque Wrench capable of 52 IN LB clockwise
Socket, 7/16" Deep

1333 East 179th Street
Cleveland, Ohio 44110
Phone: (216) - 481 - 4900
Fax: (216) - 481 - 3782
www.clevelandrange.com



Removal Procedure

1. Read and fully understand this procedure before beginning.
2. Turn OFF the electricity to the steamer at the Control Panel, the Control Power Service Disconnect switch, and the Main External Power Switch.
3. Lock out the Main External Power Switch as required.
4. Turn OFF the water at the service disconnect valves.
5. Open the Oven Compartment Door and wait for the steamer to cool (if not already cold).
6. Detach the steamer from electric and water lines.
7. Remove any accessories and detachable parts from the cooking compartment (wear DRY heatproof gloves if needed).
8. Remove the side panels.
9. Turn the steamer over.
10. Remove the base pan.
11. Remove the high limit from the heater block.
12. Disconnect the burned out heater block wires from the contactor.
13. Remove the burned out heater block.
 - **IMPORTANT: SAVE THE SUPPORT RAILS!** (See Figures 1 and 2.)
14. Clean off all the thermal joint compound from the underside of the cooking compartment where the burned out heater block was removed. Use mineral spirits or turpentine to remove any residue.
 - Wear solvent proof gloves.
 - See container label and follow manufacturer's instructions.

Replacement Procedure

1. Read and fully understand this procedure before beginning.
2. Wipe off the heater block with mineral spirits or turpentine.
 - Wear solvent proof gloves.
 - See container label and follow manufacturer's instructions.
3. Lay the heater block machined side up, (cast-in information plate side down) on a flat surface.
4. Wear latex gloves and apply a thin layer of the thermal joint compound to the machined side of the heater block using a 4" putty knife.
 - See container label and follow manufacturer's instructions.
5. Place the heater block over the mounting studs onto the cooking compartment.
 - Make sure the side with the heater block compound is against the cooking compartment.
6. Use a clean, dry rag to wipe any heater block compound off the mounting studs.

7. Place the support rails on the mounting studs as shown in Figures 1 and 2.
8. Place the washers on the mounting studs as shown in Figure 1.
9. Screw the brass 1/4-20 nuts on the mounting studs as shown in Figure 1 and tighten finger tight.

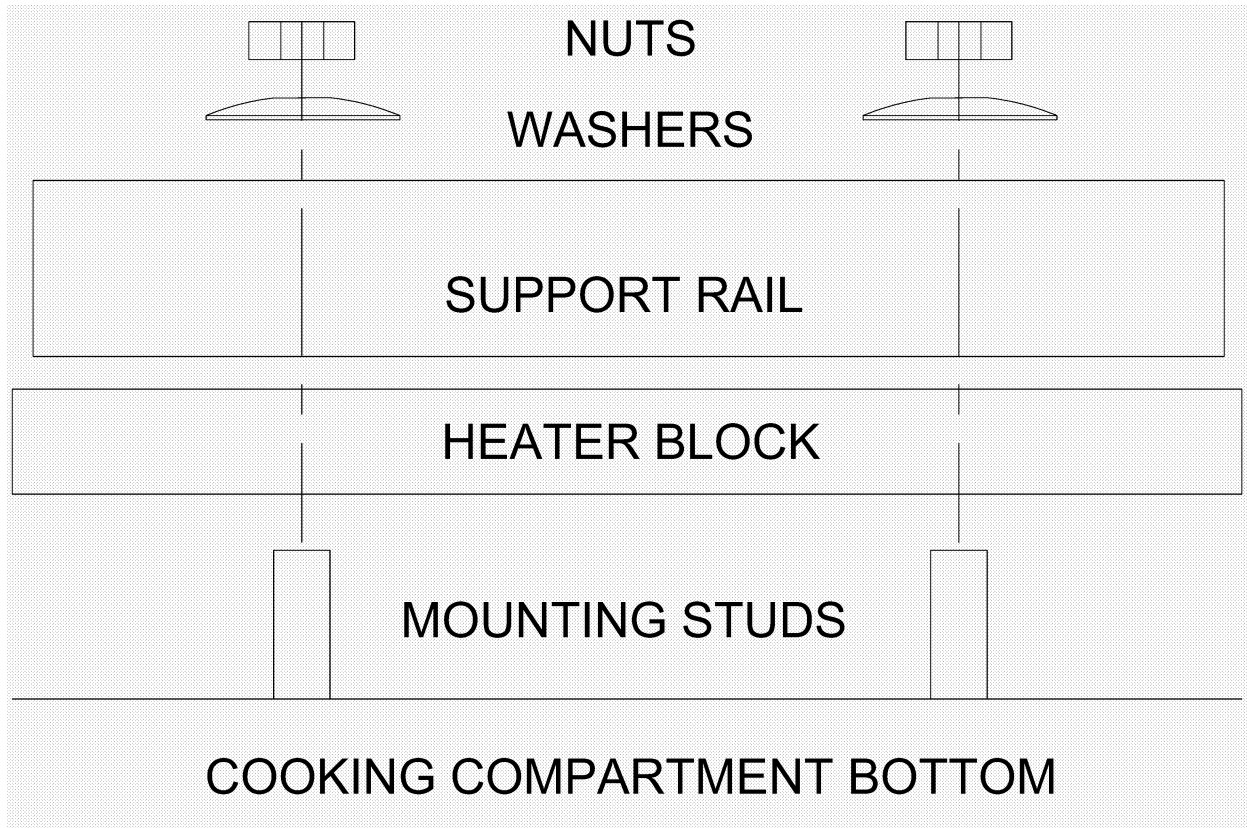

Figure 1

10. Torque nuts in sequence as shown in Figure 2 to 52 IN LB.
11. Retorque nuts in sequence as shown in Figure 2 to 52 IN LB.

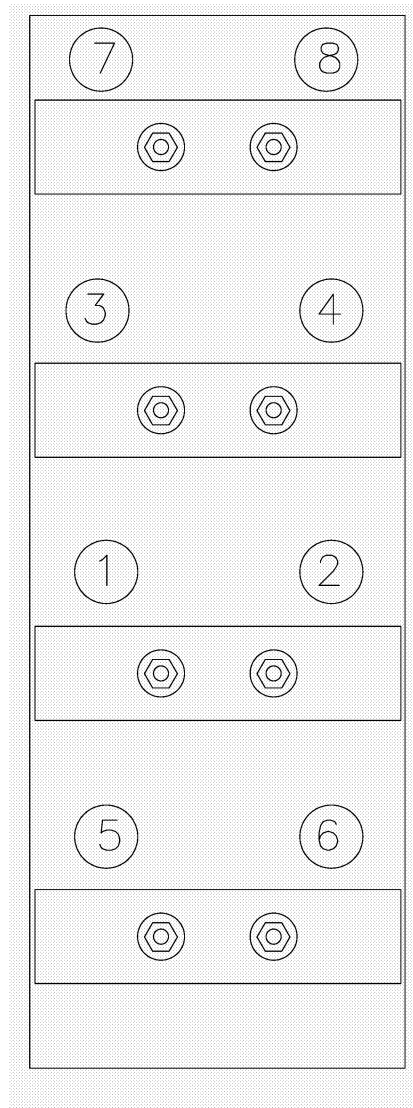
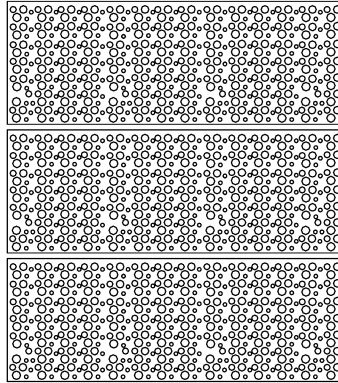

Figure 2

12. Apply 2 drops Loctite 290 on the threads of each mounting stud at the nut.
 - See container label and follow manufacturer's instructions.
13. Connect the new heater block wires to the contactor.
14. Attach the high limit to the heater block.
15. Reassemble the steamer and reattach the utilities.
 - See the Installation and Operator's manuals for details.

16. Test the new heater block for proper operation and even contact with the underside of the cooking compartment by observing the bubble pattern in the water in the steamer reservoir at start up. See Figure 3.

GOOD BUBBLE PATTERN



AT START UP, BUBBLE PATTERN SHOULD HAVE SMALL BUBBLES COVERING THE THREE RECTANGULAR HEATER BLOCKS EVENLY. THIS INDICATES GOOD, EVEN HEAT TRANSFER.

BAD BUBBLE PATTERN

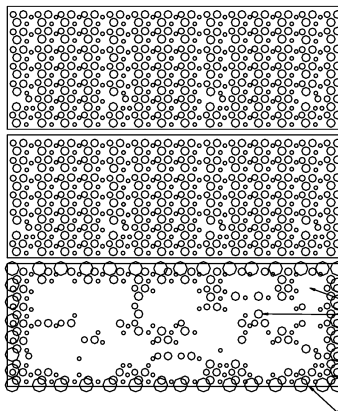

EXAMPLE:

VERY LITTLE OR NO BUBBLES

LARGE BUBBLES ON OUTSIDE EDGES

AT START UP, IF BUBBLE PATTERN HAS LARGE BUBBLES ON THE OUTSIDE EDGES OF ONE OR MORE BLOCKS, THIS INDICATES LOSS OF SURFACE CONTACT BETWEEN HEATER BLOCK AND MOUNTING SURFACE, REDUCING HEAT TRANSFER. THIS CAUSES THE HEATER BLOCK TO OVER-TEMP AND GO INTO A HI-LIMIT CONDITION.

Figure 3

If a "BAD" bubble pattern is observed, the new heater block is not working properly or is not making even contact with the underside of the cooking compartment. Call Cleveland Range Service at the phone numbers on page 1 for assistance.

17. After a "GOOD" bubble pattern is observed, return the steamer to service

SteamChef™ 3

High Speed Convection Steamer,
 Automatic Water Fill & Drain, 32,000 BTU
 Gas Boiler-Free Counter Type Design



MODEL: 22CGT3.1



Cleveland Standard Features

- Cooking capacity for up to three 12" x 20" x 2.5" deep steam table pans (1/1 G/N, 65 mm).
- High-speed gas convection steamer with open style 1.5 gallon water reservoir located at the bottom of the cooking compartment for easy access and maintenance.
- Fan forced convection steam with patented **KleanShield™** cooking compartment design. **KleanShield™** collects and removes condensate waste from the cooking compartment. This keeps the compartment clean, safe from impurities and easy to maintain. Reduces foaming and avoids contamination of the reservoir water.
- Automatic water level controls, fills when main power switch is turned ON, Low Water and High Water probes inside cooking compartment maintains water levels during cooking, eliminating the need to manually refill and monitor water level during cooking. Large overflow port in rear wall. 193° preheat and standby temperature. High Temperature Safety Shut-off.
- Steam and Fan Shut Off Control when compartment door is opened.
- 32,000 BTU high efficiency atmospheric gas boilerless style heating system.
- Front access works in a drawer style burners for easy servicing.
- Includes a 60-Minute Electro-Mechanical Timer, LED Indicator Lights for Power On and Reset. Timed and Manual Bypass Switch for constant steaming.
- Exclusive **SteamChef™** Automatic Drain Control. Compartment drains when main power is turned OFF via 1/2" ball valve with micro switch circuitry. Simple 1" NPT drain connection required with water saving cold water condenser and 3 minute rinse feature.
- Left Hand Door Hinging: Compartment Doors hinged on the left, controls on the right.
- Exclusive, durable 14 gauge stainless steel compartment door and latch withstands abuse and heavy wear. Two piece compartment door with free floating inner door is self adjustable and prevents leaks. Reversible door gasket doubles the life of the gasket.
- Heavy-duty 4" (102mm) Skid Resistant Adjustable Legs with Flanged Feet.
- UL - Gas, UL - Sanitation (NSF Standards).



Short Form Specifications

Shall be a Cleveland **SteamChef™ 3**, model 22CGT3.1, one compartment 32,000 BTU high efficiency atmospheric gas boilerless style heating system. Front access "works in a drawer" style burners for easy servicing. Standard 60-minute electro-mechanical timer. Capacity for three 2.5" (1/1 G/N, 65 mm) full size steam table pans. Includes 1/2" ball valve style automatic drain. Automatic water level controls. Heavy-duty 14 gauge stainless steel cooking compartment door and latch. **KleanShield™** clean cavity protection. 4" Adjustable Legs.

Options & Accessories

- 34" High Stainless Steel Equipment Stand (UNISTAND34)
- 5 Foot (1524mm) FDA Approved National Hose Thread style water connection kit (garden hose thread), 2 required (NHT60)
- Single Point Water Connection (SPW)

- Each compartment has capacity for: Three, 12" x 20" x 2 1/2" deep Cafeteria Pans.
- Each compartment has capacity for: Six, 12" x 20" x 1" deep Cafeteria Pans.
- Each compartment has capacity for: Two, 12" x 20" x 4" deep Cafeteria Pans.

OPERATING CLEARANCES

3" Left, 3" Right and 3" Rear.

SERVICE CLEARANCES

12" on control side. Contact factory for variances to clearances.

CONTROLS

60-minute electro mechanical timer with load compensating feature.
Three function control switch for Timed Cooking and Continuous Steaming.

APPROVALS

UL - Gas, UL - Sanitation (NSF Standards)

GAS

1/2" Dia. IPS

32,000 BTU's

SUPPLY PRESSURE: NATURAL - 4.00" W.C. minimum, 14.00" W.C. maximum
PROPANE - 12.00" W.C. minimum, 14.00" W.C. maximum

Manufacturer must be notified if unit will be used above 2,000 ft. altitude.

ELECTRICAL

115V, 1 Phase, 35 Watts.

COLD WATER

C1: Condensing Water Inlet, 35 Psi Minimum, 60 Psi Maximum.

C2: Fill Water Inlet, 35 Psi Minimum, 60 Psi Maximum.

Two 3/4" NH-F (Garden Thread) connections. Use NSF approved hose.

DRAIN CONNECTION

1" NPT-M

Do not connect other units to this drain.

Drain line must be vented. Vented drain connection included.

Do not connect drain to PVC pipe.

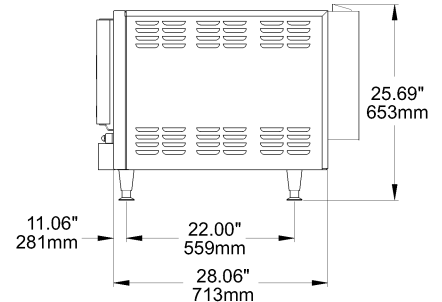
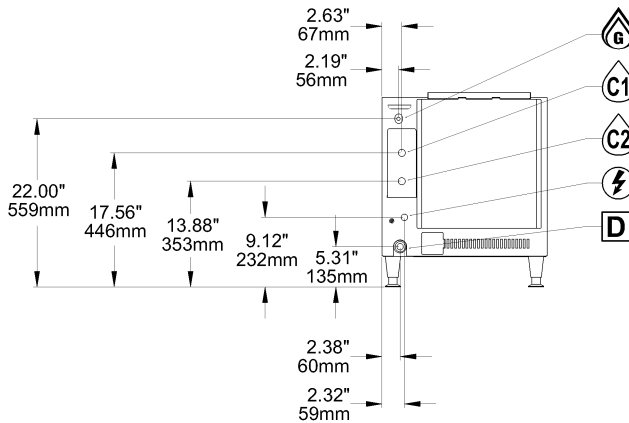
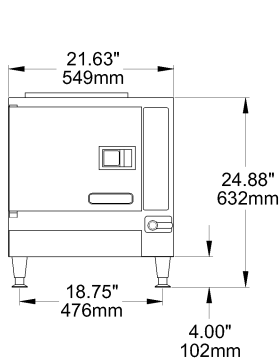
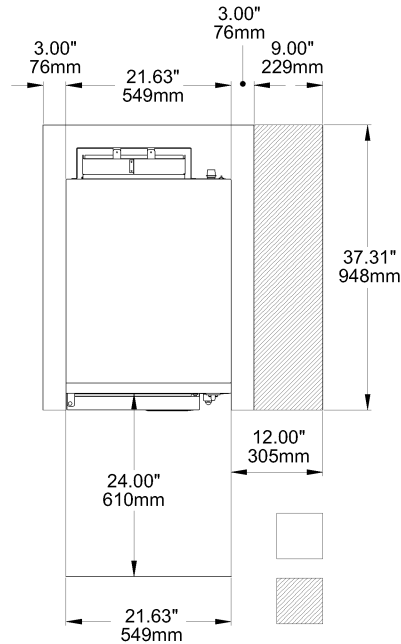
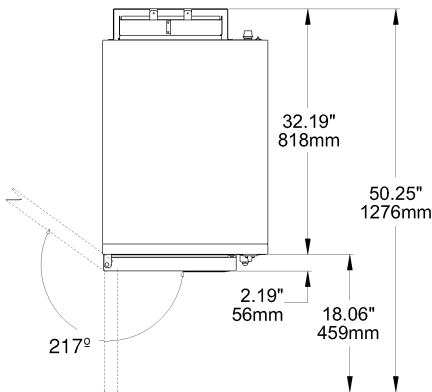

NOTES:

Cleveland Range reserves right of design improvement or modification, as warranted.

Many regional, state and local codes exist and it is the responsibility of the owner and installer to comply with the codes.

Cleveland Range equipment is built to comply with applicable standards for manufacturers. Included among those approval agencies are U.L./NSF#4 and CSA (AGA, CGA).

(NOT TO SCALE)
SECT. **B** PAGE **10**
0609
Litho in U.S.A.

SteamChef™ 6

High Speed Convection Steamer,
 Automatic Water Fill & Drain, 32,000 BTU
 Gas Boiler-Free Counter Type Design



MODEL: 22CGT6.1



Cleveland Standard Features

- Cooking capacity for up to six 12" x 20" x 2.5" deep steam table pans (1/1 G/N, 65 mm).
- High-speed gas convection steamer with open style 1.5 gallon water reservoir located at the bottom of the cooking compartment for easy access and maintenance.
- Fan forced convection steam with **KleanShield™** cooking compartment design. **KleanShield™** collects and removes condensate waste from the cooking compartment. This keeps the compartment clean, safe from impurities and easy to maintain. Reduces foaming and avoids contamination of the reservoir water.
- Automatic water level controls, fills when main power switch is turned ON, Low Water and High Water probes inside cooking compartment maintains water levels during cooking, eliminating the need to manually refill and monitor water level during cooking. Large overflow port in rear wall. 193° preheat and standby temperature. High Temperature Safety Shut-off.
- Steam and Fan Shut Off Control when compartment door is opened.
- 32,000 BTU high efficiency atmospheric gas boilerless style heating system.
- Front access "works in a drawer" style burners for easy servicing.
- Includes a 60-Minute Electro-Mechanical Timer, LED Indicator Lights for Power On and Reset. Timed and Manual Bypass Switch for constant steaming.
- Exclusive **SteamChef™** Automatic Drain Control. Compartment drains when main power is turned OFF via 1/2" ball valve with micro switch circuitry. Simple 1" NPT drain connection required with water saving cold water condenser and 3 minute rinse feature.
- Left Hand Door Hinging: Compartment Doors hinged on the left, controls on the right.
- Exclusive, durable 14 gauge stainless steel compartment door and latch withstands abuse and heavy wear. Two piece compartment door with free floating inner door is self adjustable and prevents leaks. Reversible door gasket doubles the life of the gasket.
- Heavy-duty 4" (102mm) Skid Resistant Adjustable Legs with Flanged Feet.
- UL - Gas, UL - Sanitation (NSF Standards).



Short Form Specifications

Shall be a Cleveland **SteamChef™ 6**, model 22CGT6.1, one compartment 32,000 BTU high efficiency atmospheric gas boilerless style heating system. Front access "works in a drawer" style burners for easy servicing. Standard with Compartment Controls and 60-minute electro-mechanical timer. Capacity for six 2.5" (1/1 G/N, 65 mm) full size steam table pans. Includes 1/2" ball valve style automatic drain. Automatic water level controls. Heavy-duty 14 gauge stainless steel cooking compartment door and latch. **KleanShield™** clean cavity protection. 4" Adjustable Legs.

Options & Accessories

- 34" High Stainless Steel Equipment Stand (UNISTAND34)
- 5 Foot (1524mm) FDA Approved National Hose Thread style water connection kit (garden hose thread), 2 required (NHT60)
- Single Point Water Connection (SPW)

- Each compartment has capacity for: Six, 12" x 20" x 212" deep Cafeteria Pans.
- Each compartment has capacity for: Twelve, 12" x 20" x 1" deep Cafeteria Pans.
- Each compartment has capacity for: Four, 12" x 20" x 4" deep Cafeteria Pans.

OPERATING CLEARANCES

3" Left, 3" Right and 3" Rear.

SERVICE CLEARANCES

12" on control side. Contact factory for variances to clearances.

CONTROLS

60-minute electro mechanical timer with load compensating feature.
Three function control switch for Timed Cooking and Continuous Steaming.

APPROVALS

UL - Gas, UL - Sanitation (NSF Standards)

GAS

1/2" Dia. IPS

32,000 BTU's

SUPPLY PRESSURE: NATURAL - 4.00" W.C. minimum, 14.00" W.C. maximum
PROPANE - 12.00" W.C. minimum, 14.00" W.C. maximum

Manufacturer must be notified if unit will be used above 2,000 ft. altitude.

ELECTRICAL

115V, 1 Phase, 35 Watts.

COLD WATER

C1: Condensing Water Inlet, 35 Psi Minimum, 60 Psi Maximum.

C2: Fill Water Inlet, 35 Psi Minimum, 60 Psi Maximum.

Two 3/4" NH-F (Garden Thread) connections. Use NSF approved hose.

DRAIN CONNECTION

1" NPT-M

Do not connect other units to this drain.

Drain line must be vented. Vented drain connection included.

Do not connect drain to PVC pipe.

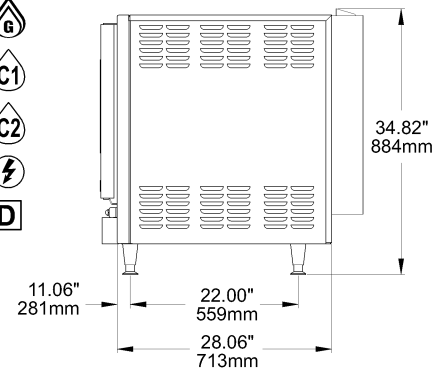
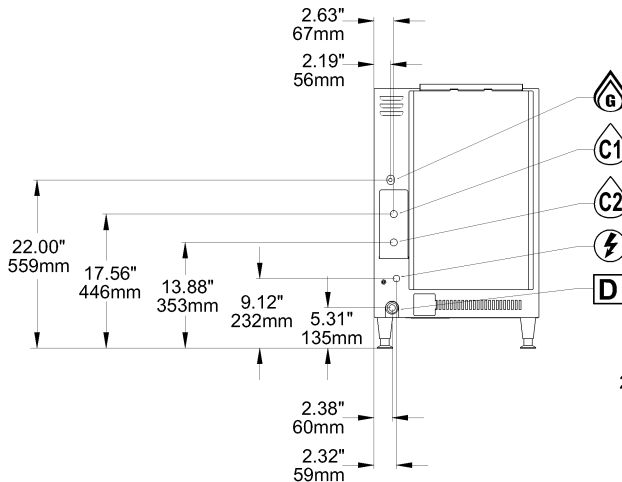
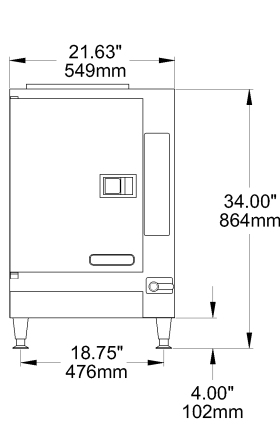
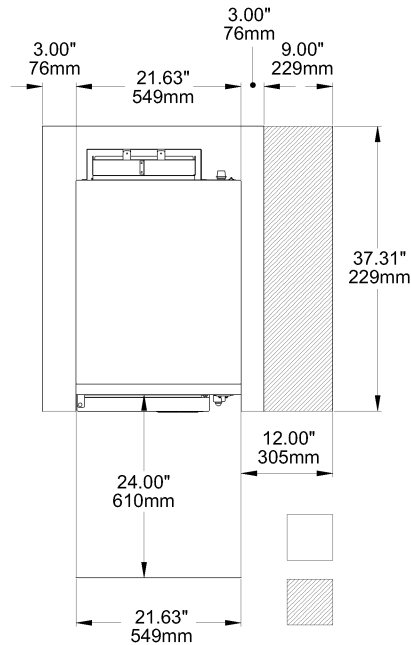
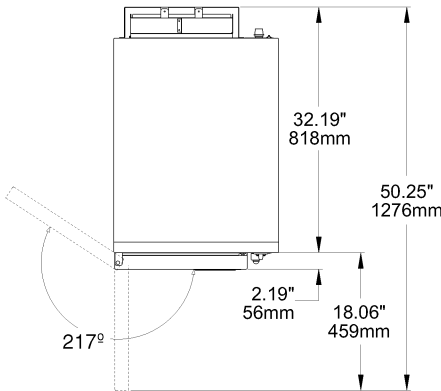

NOTES:

Cleveland Range reserves right of design improvement or modification, as warranted.
Many regional, state and local codes exist and it is the responsibility of the owner and installer to comply with the codes.
Cleveland Range equipment is built to comply with applicable standards for manufacturers. Included among those approval agencies are U.L./NSF#4 and CSA (AGA, CGA).

(NOT TO SCALE)
SECT. B PAGE 12
0609
Litho in U.S.A.

CLEVELAND RANGE 22CGT3.1/6.1 SEQUENCE OF OPERATIONS

Mechanical Timer

Starting with the timed manual switch in the timed position, and no time on the timer.

1. To turn the unit on, turn the ON/OFF lever clockwise to the ON position
 - This mechanically closes the drain.
 - Power Switch 1 changes from the NC to NO contacts.
 - Power Switch 2 changes from the NO to NC contacts.
 - 110 VAC is sent .
 - To the green power on light
 - Through the hi limit to the coil of the R2 relay
 - To the common of the now open NC R2B contacts.
 - To the NO 130 degree thermal switch
 - To the water level control board
2. With the water level board energized and no water in the generator
 - 5 seconds later the fill solenoid is energized from the fill terminal through the Power switch 2.
 - The fill solenoid opens and the generator fills.
3. The water fills to the low probe shorting it to ground
 - 110 VAC is sent from the HEAT terminal through the now closed NO R2A contacts to
 - The Temperature Control Board
 - To the open Door switch.
4. When the Door is closed and the timed/manual switch is in the timed position with no time on the timer, 110 VAC is sent
 - Through the now closed (until the cabinet reaches 205 degrees) NO contacts of the temperature control board to
 - The NC contacts of R1A to the fan motor.
 - The primary coil of the transformer
 - 24VAC is sent from the secondary of the transformer to the ignition module
 - Spark is sent to the igniter
 - 24 VAC is sent to the gas valve opening it
 - Gas comes into contact with spark and ignites sending 1.5 micro-amps Dc to the ignition module to keep the gas valve open past 4 seconds.
5. When the timed/manual switch is in the timed position and time is on the timer:
 - 110 VAC is sent from the NO terminal of the timer
 - To the timer motor causing it to count down.
 - To the coil of the R1 Relay
 - Through the now closed NO R1A contacts to the Fan motor.

- 110 VAC is sent through the now closed (until the cabinet reaches 205 degrees) NO contacts of the temperature control board to
 - The primary coil of the transformer
 - 24VAC is sent from the secondary of the transformer to the ignition module
 - Spark is sent to the igniter
 - 24 VAC is sent to the gas valve opening it
 - Gas comes into contact with spark and ignites sending 1.5 micro-amps Dc to the ignition module to keep the gas valve open past 4 seconds.
 - When the timer times out power is sent from the NO timer contact through the NC contact to the 3 second timer and then to the buzzer for 3 seconds.
6. When the timed/manual switch is in the manual position
- 110 VAC is sent to terminal 2 of the 60 Minute solid state timer. For 60 minutes 110 VAC is sent from terminal 1 of the timer to
 - To the timer motor causing it to count down.
 - To the coil of the R1 Relay
 - Through the now closed NO R1A contacts to the Fan motor.
 - 110 VAC is sent through the now closed (until the cabinet reaches 205 degrees) NO contacts to
 - The primary coil of the transformer
 - 24VAC is sent from the secondary of the transformer to the ignition module
 - Spark is sent to the igniter
 - 24 VAC is sent to the gas valve opening it
 - Gas comes into contact with spark and ignites sending 1.5 micro-amps Dc to the ignition module to keep the gas valve open past 4 seconds.
7. Whenever the water level drops below the high probe for 5 seconds power is sent to the FILL terminal again.
8. When the on/off lever is turned off :
- The drain is mechanically opened, and the reservoir begins to drain.
 - The green “Power On” indicator light is de-energized.
 - Power is sent to the 3-minute timer and the fill solenoid is energized for 3 minutes flushing the drain.

STEAMCHEF 3.1 / 6.1 MECH TIMER (GAS)

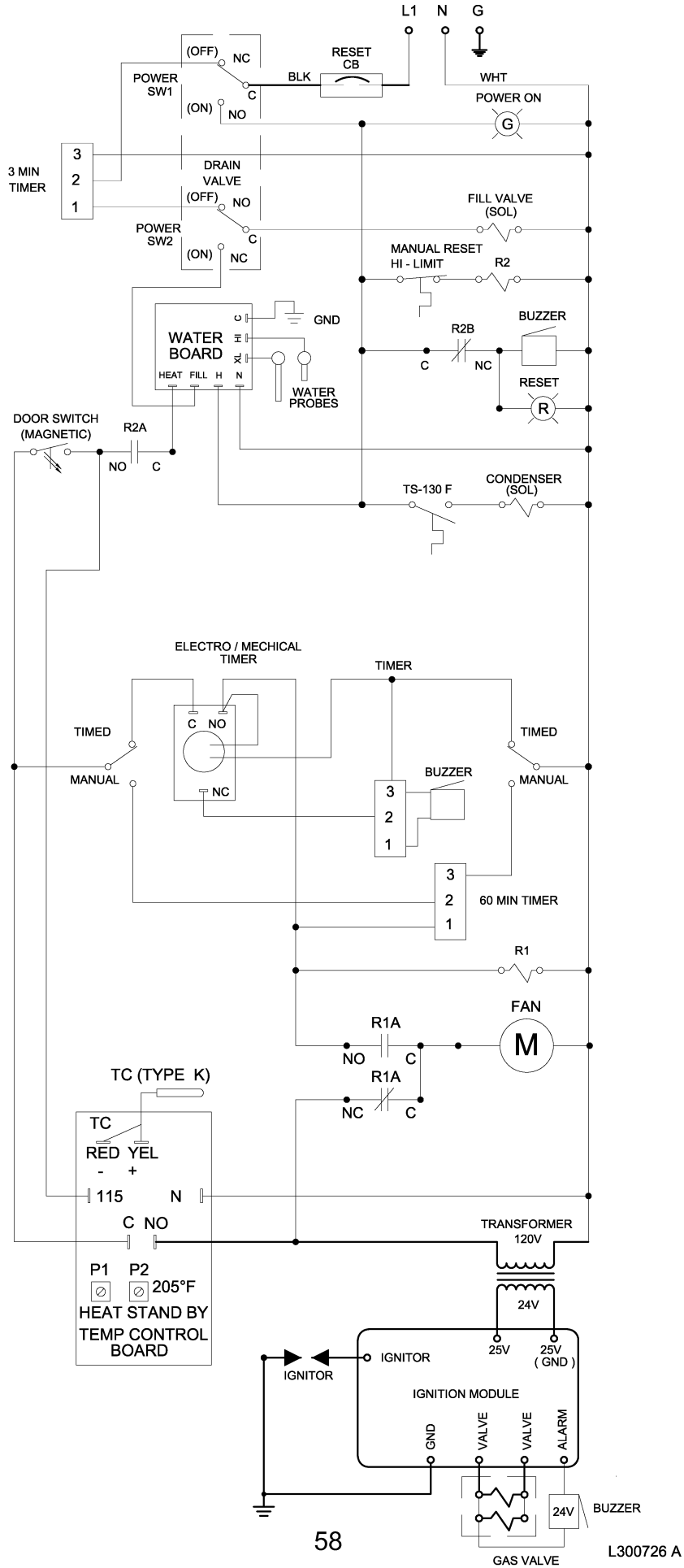

STEAMCHEF 3.1 / 6.1 MECH TIMER (GAS)

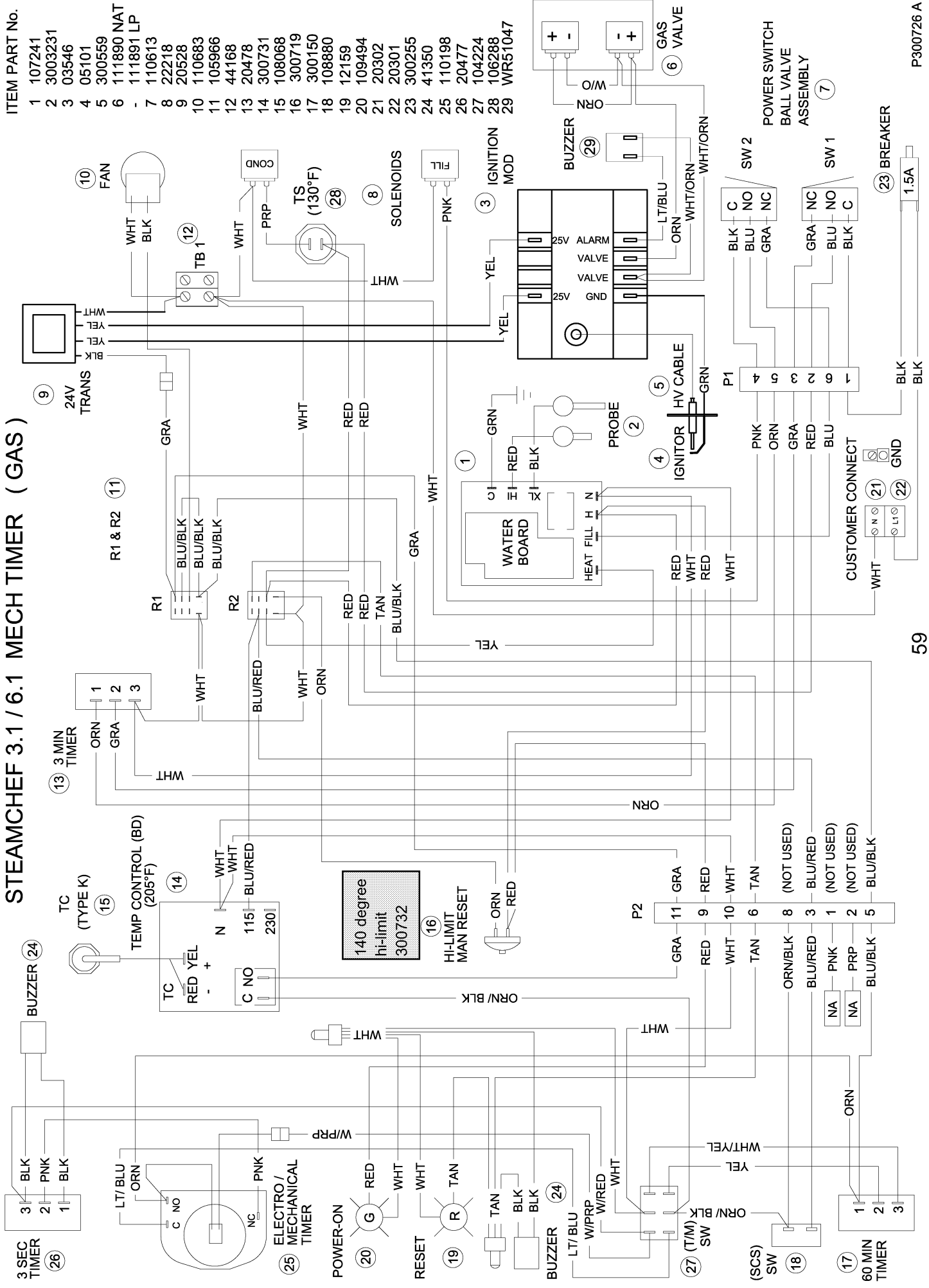

- ITEM PART No.
- 1 107241
 - 2 3003231
 - 3 03546
 - 4 05101
 - 5 300559
 - 6 111890 NAT
 - 111891 LP
 - 7 110613
 - 8 22218
 - 9 20528
 - 10 110683
 - 11 105966
 - 12 44168
 - 13 20478
 - 14 300731
 - 15 108068
 - 16 300719
 - 17 300150
 - 18 108880
 - 19 12159
 - 20 109494
 - 21 20302
 - 22 20301
 - 23 300255
 - 24 41350
 - 25 110198
 - 26 20477
 - 27 104224
 - 28 106288
 - 29 WR51047

CLEVELAND RANGE 22CGT3.1/6.1 SEQUENCE OF OPERATIONS

Electronic Timer

Starting with the timed manual switch in the timed position, and no time on the timer.

1. To turn the unit on, turn the ON/OFF lever clockwise to the ON position
 - This mechanically closes the drain.
 - Power Switch 1 changes from the NC to NO contacts.
 - Power Switch 2 changes from the NO to NC contacts.
 - 110 VAC is sent .
 - To the green power on light
 - Through the hi limit to the coil of the R2 relay
 - To the common of the now open NC R2B contacts.
 - To the NO 130 degree thermal switch
 - To the water level control board
 - To the primary of the Timer Transformer
 - 24VAC is sent from the secondary of the timer transformer to the Electronic timer
2. With the water level board energized and no water in the generator
 - 5 seconds later the fill solenoid is energized from the fill terminal through the Power switch 2.
 - The fill solenoid opens and the generator fills.
3. The water fills to the low probe shorting it to ground
 - 110 VAC is sent from the HEAT terminal through the now closed NO R2A contacts to
 - The Temperature Control Board
 - To the open Door switch.
4. When the Door is closed and the timed/manual switch is in the timed position with no time on the timer, 110 VAC is sent
 - Through the now closed (until the cabinet reaches 205 degrees) NO contacts of the temperature control board to
 - The NC contacts of R1A to the fan motor.
 - The primary coil of the transformer
 - 24VAC is sent from the secondary of the transformer to the ignition module
 - Spark is sent to the igniter
 - 24 VAC is sent to the gas valve opening it
 - Gas comes into contact with spark and ignites sending 1.5 micro-amps Dc to the ignition module to keep the gas valve open past 4 seconds.
5. When the timed/manual switch is in the timed position and time is on the timer:
 - 110 VAC is sent from the NO terminal of the timer through the fuse
 - To the coil of the R1 Relay

- Through the now closed NO R1A contacts to the Fan motor.
 - 110 VAC is sent through the now closed (until the cabinet reaches 205 degrees) NO contacts of the temperature control board to
 - The primary coil of the transformer
 - 24VAC is sent from the secondary of the transformer to the ignition module
 - Spark is sent to the igniter
 - 24 VAC is sent to the gas valve opening it
 - Gas comes into contact with spark and ignites sending 1.5 micro-amps Dc to the ignition module to keep the gas valve open past 4 seconds.
 - When the timer times out the timer buzzes and power is removed from the R1 coil and from the Fan motor.
6. When the timed/manual switch is in the manual position
- 110 VAC is sent to terminal 2 of the 60 Minute solid state timer. For 60 minutes 110 VAC is sent from terminal 1 of the timer.
 - To the coil of the R1 Relay
 - Through the now closed NO R1A contacts to the Fan motor.
 - 110 VAC is sent through the now closed (until the cabinet reaches 205 degrees) NO contacts to
 - The primary coil of the transformer
 - 24VAC is sent from the secondary of the transformer to the ignition module
 - Spark is sent to the igniter
 - 24 VAC is sent to the gas valve opening it
 - Gas comes into contact with spark and ignites sending 1.5 micro-amps Dc to the ignition module to keep the gas valve open past 4 seconds.
7. Whenever the water level drops below the high probe for 5 seconds power is sent to the FILL terminal again.
8. When the on/off lever is turned off :
- The drain is mechanically opened, and the reservoir begins to drain.
 - The green “Power On” indicator light is de-energized.
 - Power is sent to the 3-minute timer and the fill solenoid is energized for 3 minutes flushing the drain.

STEAMCHEF 3.1 / 6.1 ELECTRONIC TIMER (GAS)

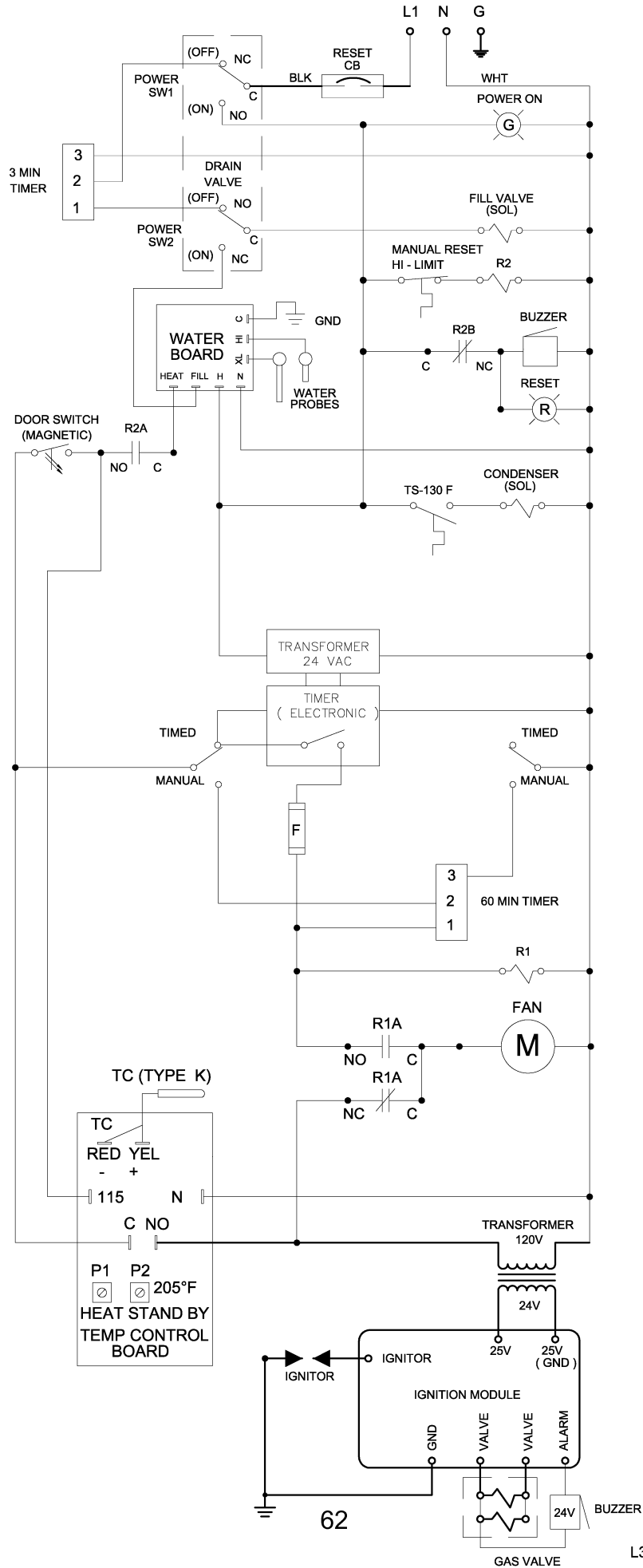

L300727 A

STEAMCHEF 3.1 / 6.1 ELECTRONIC TIMER (GAS)

ITEM PART No.

- 1 107241
- 2 3003231
- 3 03546
- 4 05101
- 5 300559
- 6 111890 NAT
- 7 111891 LP
- 8 22218
- 9 20528
- 10 110683
- 11 105966
- 12 44168
- 13 20478
- 14 300731
- 15 108068
- 16 300719
- 17 300150
- 18 108880
- 19 12159
- 20 20528
- 21 20302
- 22 20301
- 23 300255
- 24 41350
- 25 104224
- 26 106909
- 27 104389
- 28 106288
- 29 WR51047

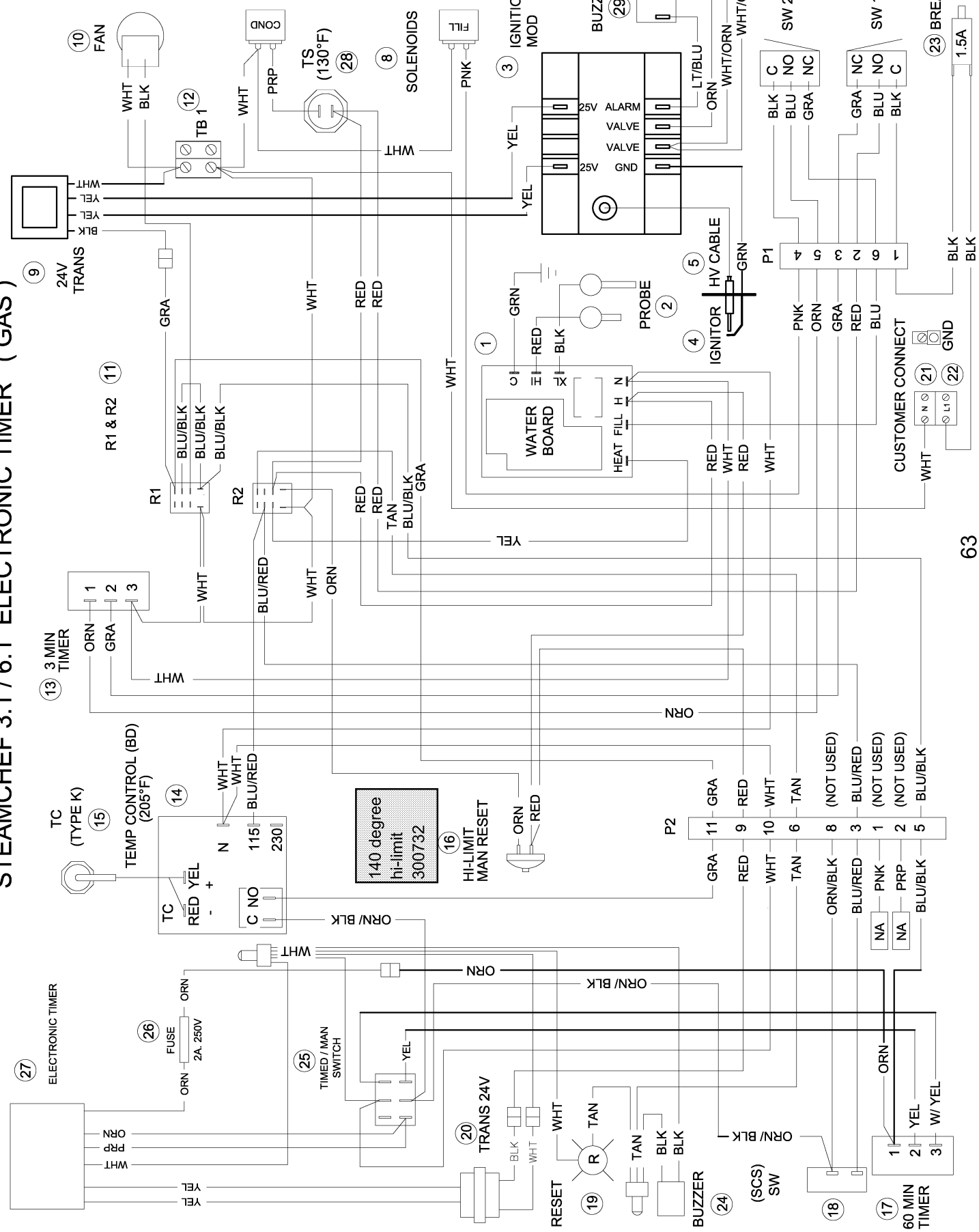

63

P300727 A

CLEVELAND RANGE 22CGT3.1/6.1 SEQUENCE OF OPERATIONS

ON/OFF

1. To turn the unit on, turn the ON/OFF lever clockwise to the ON position
 - This mechanically closes the drain.
 - Power Switch 1 changes from the NC to NO contacts.
 - Power Switch 2 changes from the NO to NC contacts.
 - 110 VAC is sent .
 - To the green power on light
 - Through the hi limit to the coil of the R2 relay
 - To the common of the now open NC R2B contacts.
 - To the NO 130 degree thermal switch
 - To the water level control board
2. With the water level board energized and no water in the generator
 - 5 seconds later the fill solenoid is energized from the fill terminal through the Power switch 2.
 - The fill solenoid opens and the generator fills.
3. The water fills to the low probe shorting it to ground
 - 110 VAC is sent from the HEAT terminal through the now closed NO R2A contacts to
 - The Temperature Control Board
 - To the open Door switch.
4. When the Door is closed and the on/off switch is in the off position, 110 VAC is sent
 - Through the now closed (until the cabinet reaches 205 degrees) NO contacts of the temperature control board to
 - The NC contacts of R1A to the fan motor.
 - The primary coil of the transformer
 - 24VAC is sent from the secondary of the transformer to the ignition module
 - Spark is sent to the igniter
 - 24 VAC is sent to the gas valve opening it
 - Gas comes into contact with spark and ignites sending 1.5 micro-amps Dc to the ignition module to keep the gas valve open past 4 seconds.
5. When the on/off switch is in the on position
 - 110 VAC is sent to terminal 2 of the 60 Minute solid state timer. For 60 minutes 110 VAC is sent from terminal 1 of the timer to
 - To the coil of the R1 Relay
 - Through the now closed NO R1A contacts to the Fan motor.
 - 110 VAC is sent through the now closed (until the cabinet reaches 205 degrees) NO contacts of the temperature control board to
 - The primary coil of the transformer

- 24VAC is sent from the secondary of the transformer to the ignition module
 - Spark is sent to the igniter
 - 24 VAC is sent to the gas valve opening it
 - Gas comes into contact with spark and ignites sending 1.5 micro-amps Dc to the ignition module to keep the gas valve open past 4 seconds.
6. Whenever the water level drops below the high probe for 5 seconds power is sent to the FILL terminal again.
7. When the on/off lever is turned off :
- The drain is mechanically opened, and the reservoir begins to drain.
 - The green “Power On” indicator light is de-energized.
 - Power is sent to the 3-minute timer and the fill solenoid is energized for 3 minutes flushing the drain.

STEAMCHEF 3.1 / 6.1 ON/OFF (GAS)

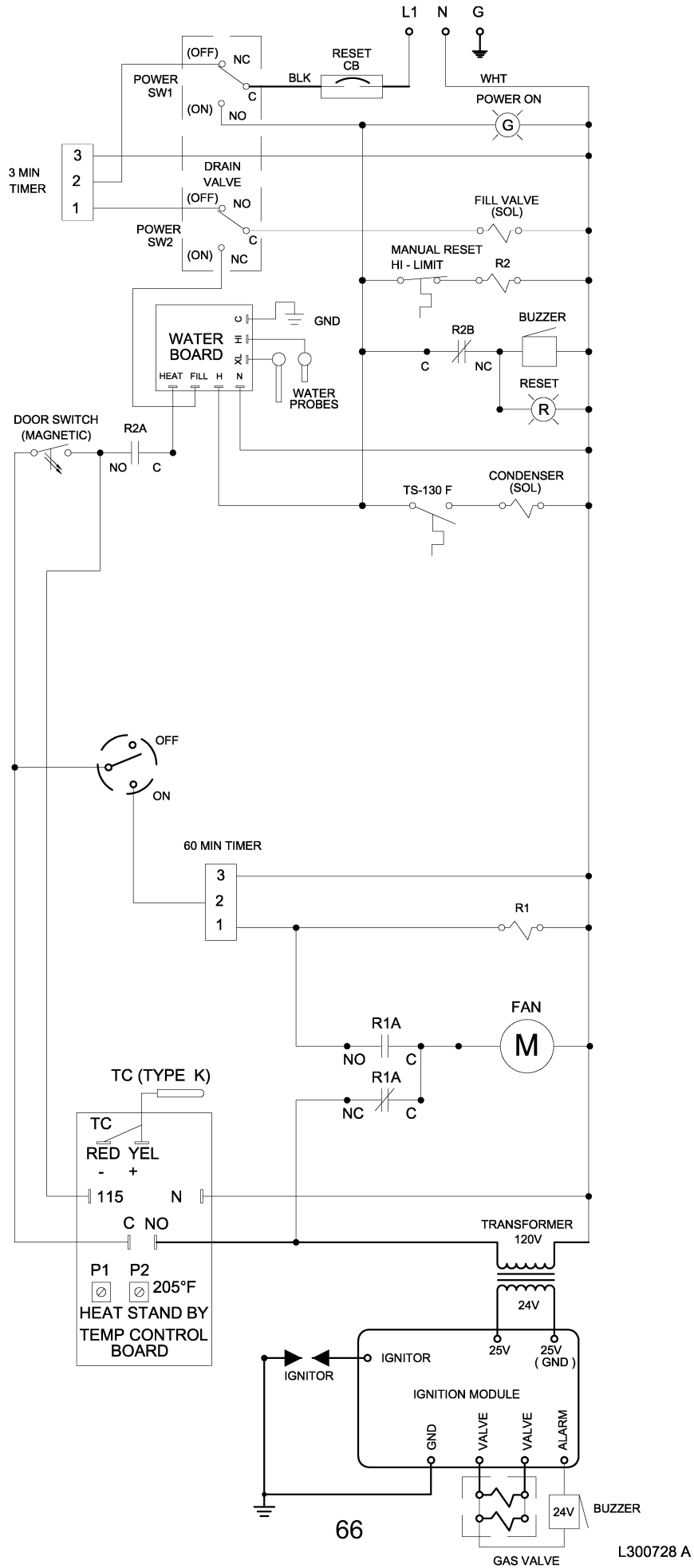

66

L300728 A

STEAMCHEF 3.1 / 6.1 ON/OFF (GAS)

ITEM PART No.

- 1 107241
- 2 3003231
- 3 03546
- 4 05101
- 5 300559
- 6 111890 NAT
- 7 111891 LP
- 8 110613
- 9 22218
- 10 20528
- 11 110683
- 12 105966
- 13 44168
- 14 20478
- 15 300731
- 16 108068
- 17 300719
- 18 300150
- 19 108880
- 20 12159
- 21 109494
- 22 20302
- 23 20301
- 24 300255
- 25 41350
- 26 102533
- 27 102534
- 28 106288
- 29 WR51047

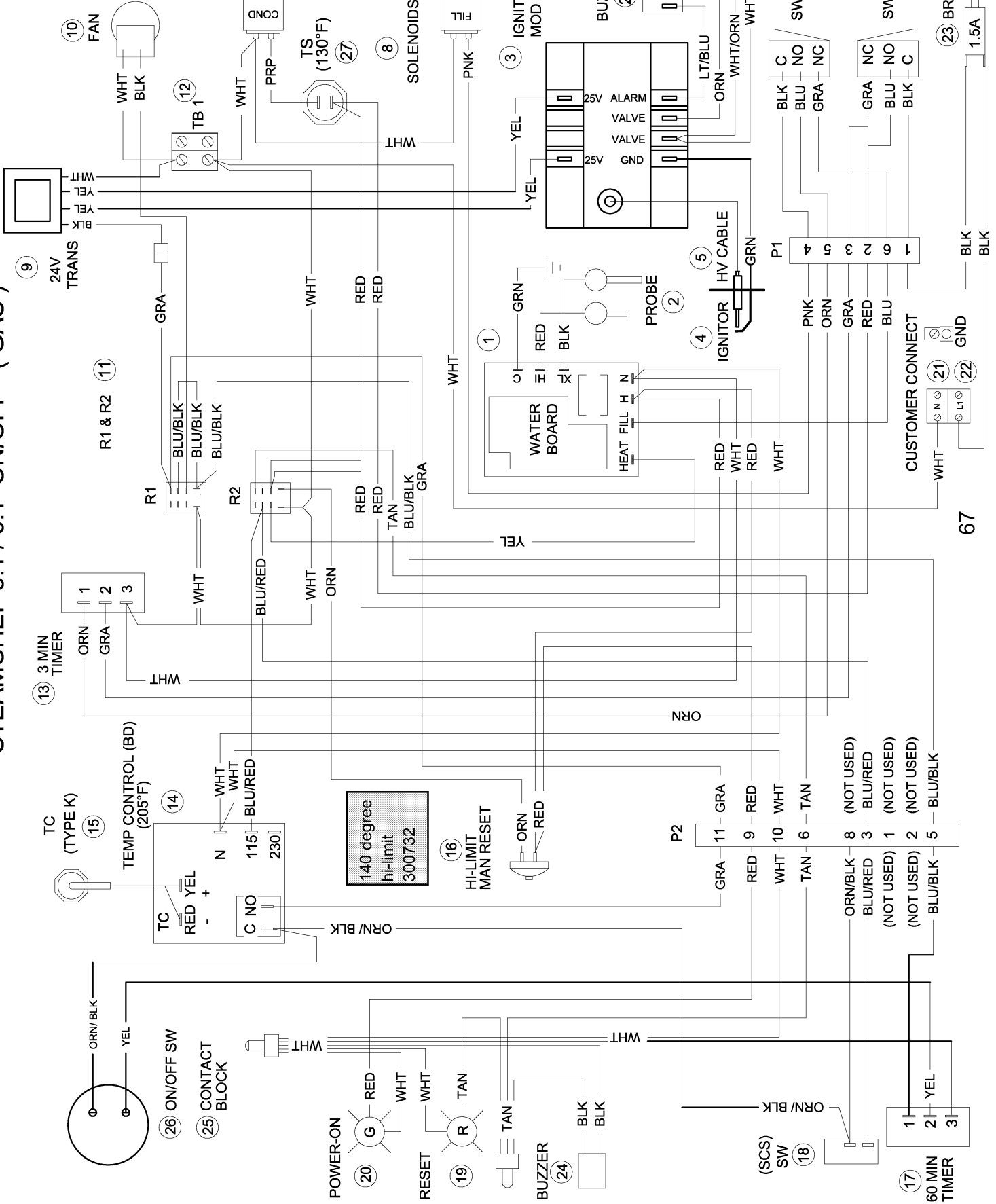

67

P300728 A

