

Technical Training Handbook and Reference Guide



**Technical Training Handbook
and
Reference Guide**

**Section 4 : Cooking
Cabinet**

Cooking Cabinets

Table of Contents

• Egg Test	1
• Convection Cabinet	2
• Pressure vs Temp	10
• Pressure Cabinet	11
• Anti Flex Kit	13
• Pressure Convection Cabinet	14

Egg Test

To test proper steaming on convection steamers

To evaluate whether a convection steamer is producing normal cooking performance, conduct the Egg Test as follows (NOTE: this test is not valid for pressure steamers). A properly operating steamer will produce cooked eggs as follows.

Turn on the steamer so that steam is being produced. After steam has begun to enter the compartment, preheat by turning the timer on for ten minutes. After the compartment is preheated follow the instructions as listed below.

1. Place a fresh egg on a perforated steam pan in the middle of the cavity.
2. Close the door and set the timer as directed by the size chart below

Size	Convection Steamer	SteamCub
Medium	11 minutes	13 minutes
Large	12 minutes	14 minutes
Extra Large	12 minutes	15 minutes

3. When time is complete, carefully remove the egg and place in a container with cold water running over it.
4. Let cool under cold running water for 5 minutes.
5. After cooling, crack egg shell and peel.

The result will be a perfectly hard boiled egg.

Note: It is not recommended to keep eggs on your service truck.

CLEVELAND RANGE
SEQUENCE OF OPERATIONS
Convection Top
Electronic Timer

1. To turn the unit on, depress the red on/off rocker switch at the base.
 - 115 VAC is sent to the red indicator light in the switch
 - 115 VAC is sent to the 24 VAC timer transformer.
 - 24 VAC is sent to the timer.
 - 115 VAC is sent to the timed/manual switch.
2. With the timed/manual switch in the timed position (with time on the timer) or in the manual position.
 - The timer display alternates between “PAUS” and the set time.
 - 115 VAC is sent through the optional door switch.
 - 115 VAC is sent to the condensate solenoid and cold water is sent to the condensate spray nozzle.
 - 115 VAC is sent to the steam solenoid and steam is sent to the cooking cabinet. There the steam is directed around the product and pulled down the drain by the condensate spray.
 - When the cooking compartment reaches 193 degrees internally the thermal switch closes and the timer begins to count down.
3. When the timer counts down in the timed position:
 - 115 VAC is removed from the condensate circuit.
 - 115 VAC is removed from the steam solenoid.
4. The unit is turned off by depressing the red rocker switch.

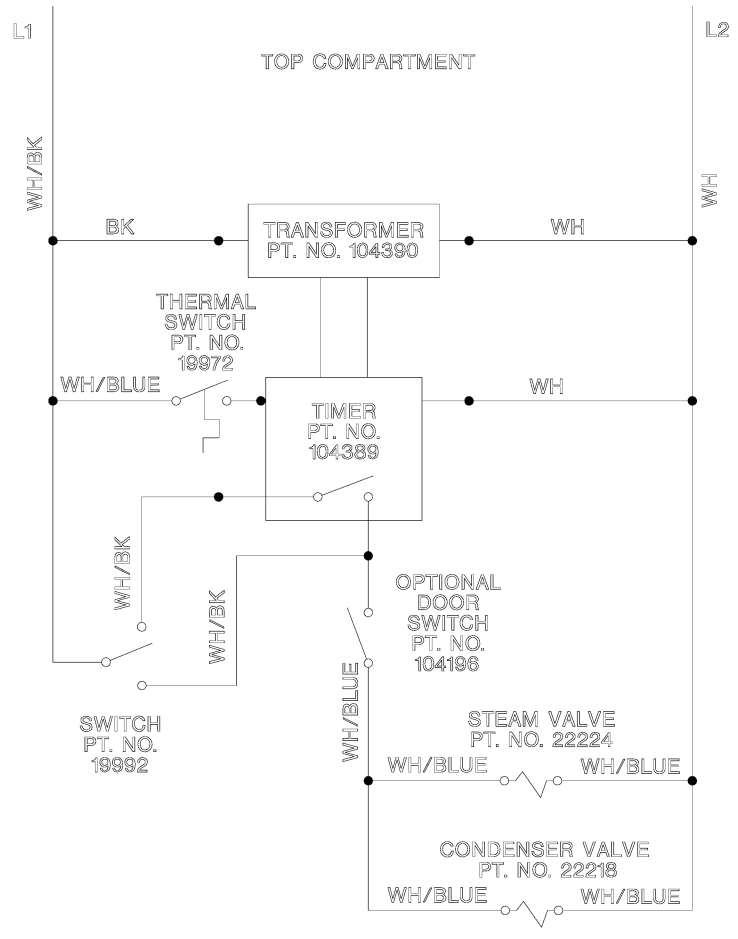

COMPARTMENT CONTROL - ELECTRONIC TIMER 104124 A

CLEVELAND RANGE
SEQUENCE OF OPERATIONS
Convection Top
Mechanical Timer

1. To turn the unit on, depress the red on/off rocker switch at the base.
 - 115 VAC is sent to the red indicator light in the switch
 - 115 VAC is sent to the timed/manual switch.

2. With the timed/manual switch in the timed position (with time on the timer) or in the manual position.
 - 115 VAC is sent through the optional door switch.
 - 115 VAC is sent to the condensate solenoid and cold water is sent to the condensate spray nozzle.
 - 115 VAC is sent to the steam solenoid and steam is sent to the cooking cabinet. There the steam is directed around the product and pulled down the drain by the condensate spray.

3. When the timer counts down in the timed position:
 - 115 VAC is removed from the condensate circuit.
 - 115 VAC is removed from the steam solenoid.
 - 115 VAC is sent to the 3-second timer
 - 115 VAC is sent from the 3-second timer to the buzzer for 3 seconds.

4. The unit is turned off by depressing the red rocker switch.

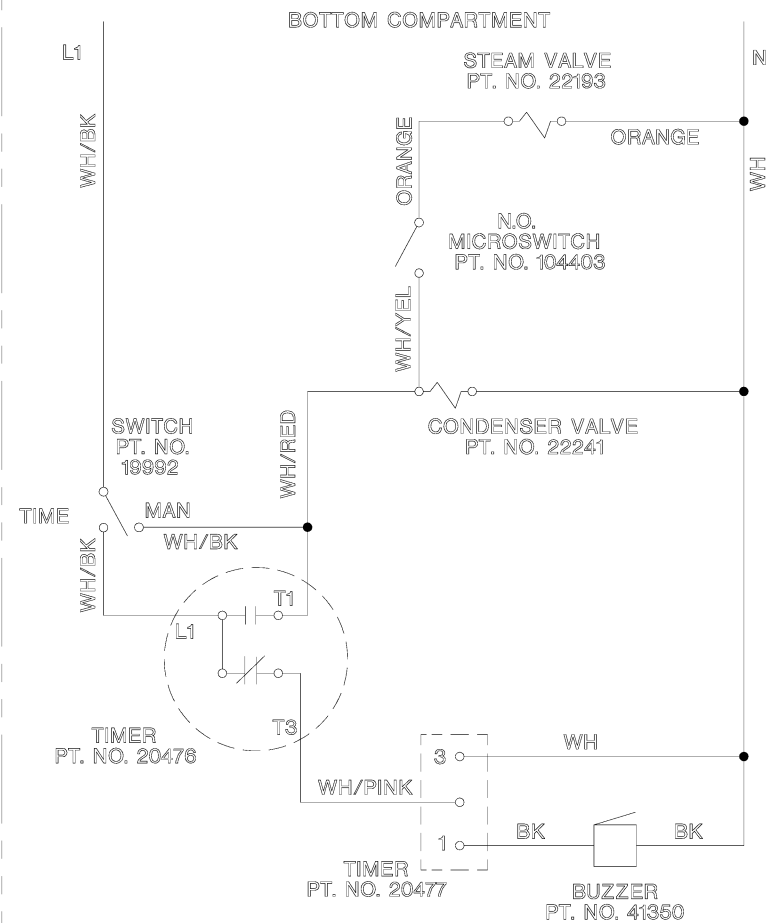
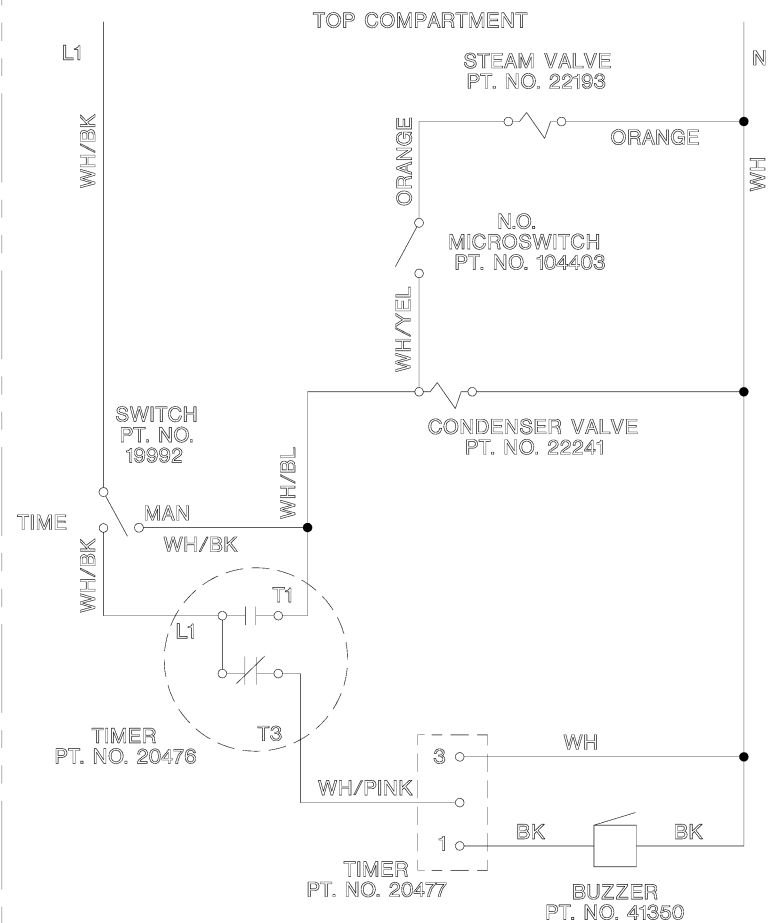

COMPARTMENT WIRING - MECHANICAL CONTROL 104212B

CLASSIC CONVECTION STEAMERS 15 PSI BOILER BASE STYLE

Project _____
Item _____
Quantity _____
FCSI Section _____
Approval _____
Date _____

ConvectionPro XVI® CONVECTION STEAMERS

TWO LARGE COMPARTMENTS, PRESSURELESS
300M BTU GAS FIRED STEAM GENERATOR
36" WIDE CABINET BASE DESIGN, with NICKELGUARD™

MODEL: 36-CGM-16-300

Cleveland Standard Features

- Cooking Capacity for up to eight 12" x 20" x 2½" deep Cafeteria Pans per compartment, or four 18" x 26" Buns Pans.
- Pressureless cooking with forced convection steam, permitting doors to be opened while cooking continues.
- Solid State Controls operate water level and safety functions.
- Each compartment is equipped with a 60 minute mechanical timer, separate bypass switch for constant steaming.
- **Instant Steam Standby Mode:** Holds generator at steaming temperature. Allows unit to start cooking instantly.
- **Durable 10 Gauge Stainless Steel Construction:** For Compartment Door and Steam Cooking Cavity.
- **Separate Main Power Switch for "On/Off"**
- **Exclusive Steam Cooking Distribution System:** The exclusive Convection Jets produce a high velocity convection steam without fans. Coved Corner design in cooking compartment distributes heat evenly and is easy to keep clean. Creased bottom enhances drainage. Cold Water Condenser for each compartment maintains a dry steam. Fully insulated cooking compartment for thermal efficiency. Removable Stainless Steel Slide Racks for easy cleaning.
- **Heavy duty, one piece, solid compartment door design with replaceable door gasket**
- **Left Hand Door Hinging:** Compartment Doors hinged left, controls on the right.
- Modular Cabinet Base with Hinged Door.
- **Heavy duty Stainless Steel Base Frame.**
- **High Efficiency Gas Steam Generator with NickelGuard,** Electronic Spark Ignition and Automatic Water Fill on start up.
- **Automatic Generator Drain at shutdown:** Contains a "Water Jet" Spray Rinse Cleaning Cycle to keep drain clear.
- **Automatic Water Level Control System** with Low Water Power Cut-off Circuit.
- Steam generator equipped with High Limit Pressure Safety Switch, 15 psi Safety Valve, and Steam Generator Pressure Gauge.
- **NSF Certified 6" Stainless Steel Legs** with adjustable flanged feet for a one inch level adjustment.
- Gas Pressure Regulator and Control Valve.
- Standard Voltage for Control: 115 volts, 60 Hz, single phase.
- All Controls are serviceable from the front.
- Compartment Door Steam Shut Off Switch.
- Secondary Low Water Cut-Off, factory installed (CALG)
(Required for AZ. AR. CA. CO. CT. DE. FL. GA. HI. IL. IA. KS. MD. MA. MI. MN. MT. NE. NV. NM. NC. OK. OR. PR. RI. TN. UT. VA. WA. WV., Buffalo, NY, Wash. DC)



Short Form Specifications

Shall be Two Large Compartments, CLEVELAND Convection Steamer, Gas-fired Steam Generator, Model 36-CGM-16-300, NickelGuard, 300M BTU, ___ gas, ___ volts, ___ Hz, single phase. Solid State Controls operate timing, water level and safety functions. Type 304 Stainless Steel cooking compartment. Insulated cooking compartments. One 60 minute Mechanical Timer with Touch Control per compartment. Audible and Visual Signals for cycle completion and steam shut-off.

Options & Accessories

- Electronic Timer with Compensating Load Feature. (ETC)
- ON/OFF Steam Switch only for compartment controls (MC)
- Cafeteria pans in depths of 1", 2½", 4" and 6"
- 18" x 26" Bun Pans
- Stainless Steel Insulated Flue Cover (SSF)
- Quick Disconnect for gas line (QDC)
- Correctional Packages
- Boiler Descaling Pump Kit (107142)
- Water Filters
- Rear Gas Connection (RGT)

SECT. III PAGE 27
0609

Each compartment has capacity for:

- Eight, 12" x 20" x 2 1/2" deep Cafeteria Pans. Can accommodate 18" x 26" Bun Pans.

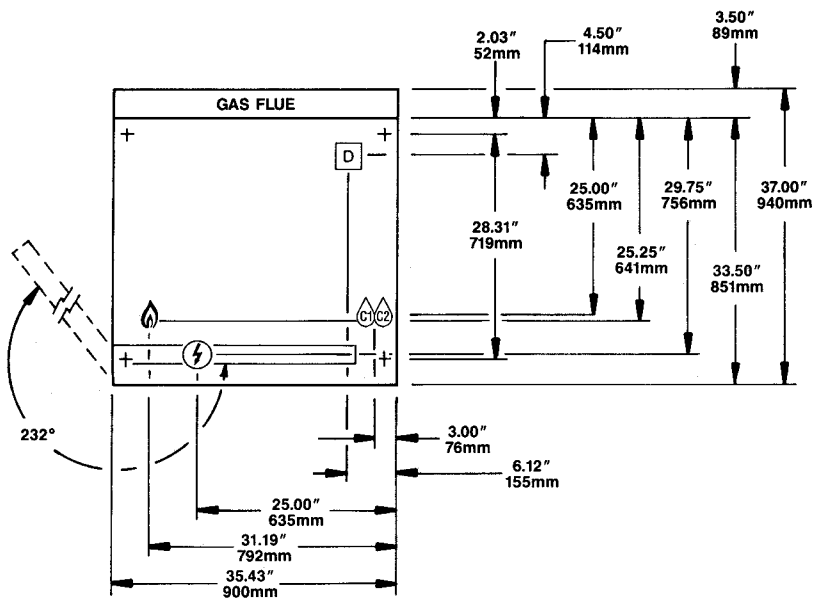

WATER QUALITY REQUIREMENT

The recommended minimum water quality standards whether untreated or pre-treated, based upon 10 hours of use per day, and a Daily Blowdown, are as follows:

TOTAL DISSOLVED SOLIDS	less than 60 parts per million
TOTAL ALKALINITY	less than 20 parts per million
SILICA	less than 13 parts per million
pH FACTOR	greater than 7.5
CHLORINE	less than 30 parts per million

Consult a local water treatment specialist for an on site water analysis for recommendations concerning steam generator feed water treatment (if required), in order to remove or reduce harmful concentrations of minerals. The use of highly mineralized water will mean that more frequent servicing of the steam generator will be necessary. The fact that a water supply is potable is not proof that it will be suitable for the generator.

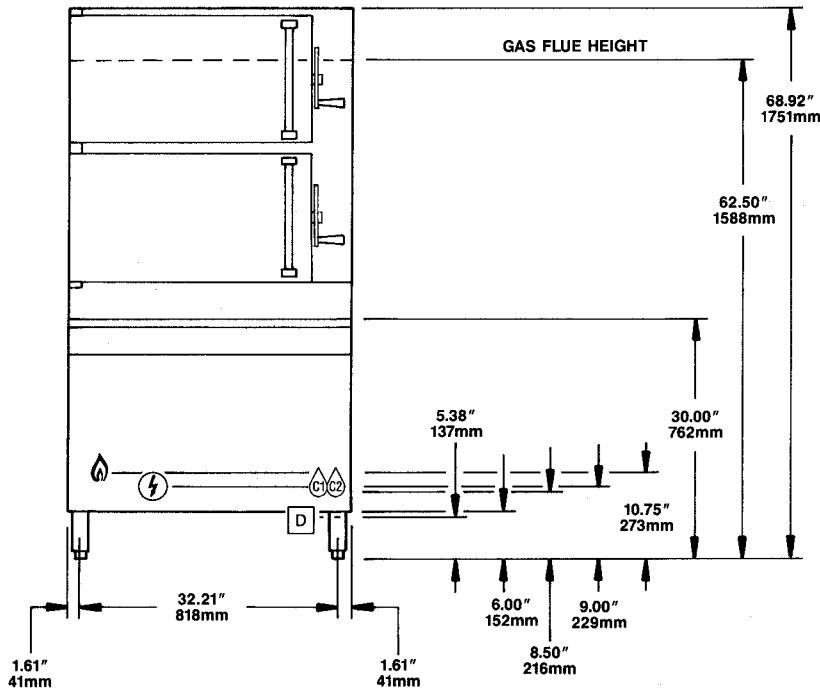

GAS		ELECTRIC	WATER	DRAINAGE	CLEARANCE
NATURAL	PROPANE	115V-1 PH 25 watts per compartment. 50 watt Steam Generator Control. ** Do not connect to GFI outlet. See note below.	35 psi minimum 60 psi maximum cold water 1/4" NPT Condenser feed 3/8" NPT Boiler feed	1 1/2" IPS common drain. Do not connect any other units to this drain. Floor Drain must be located outside the confines of the equipment base. Drain line must be vented. Do not use PVC pipe for drain.	Right - 6", Left - 6", Rear - 6" (12" on control side if adjoining wall or equipment is over 30" high for service access) For use in non-combustible locations. Contact factory for variances to clearances
Piping-1" IPS Supply pressure: 4.00" W.C. minimum 14.00" W.C. maximum					
Piping-1" IPS Supply pressure: 12.00" W.C. minimum 14.00" W.C. maximum					
Manufacturer must be notified if unit is to be used above 2,000 ft. altitude.					

NOTES:

**DO NOT CONNECT TO GFI OUTLET. CLEVELAND RANGE RECOMMENDS GAS FIRED 120 VOLT STEAMERS BE HARD WIRED DIRECTLY TO ELECTRICAL SYSTEM.

Cleveland Range reserves right of design improvement or modification, as warranted.

Many regional, state and local codes exist and it is the responsibility of the owner and installer to comply with the codes.

Cleveland Range equipment is built to comply with applicable standards for manufacturers. Included among those approval agencies are ASME/N. Bd, UL/NSF#4 and CSA (AGA, CGA).

(NOT TO SCALE)
SECT. III PAGE 28

0609

Litho in U.S.A

16 PAN CONVECTION - ELECTRONIC TIMER

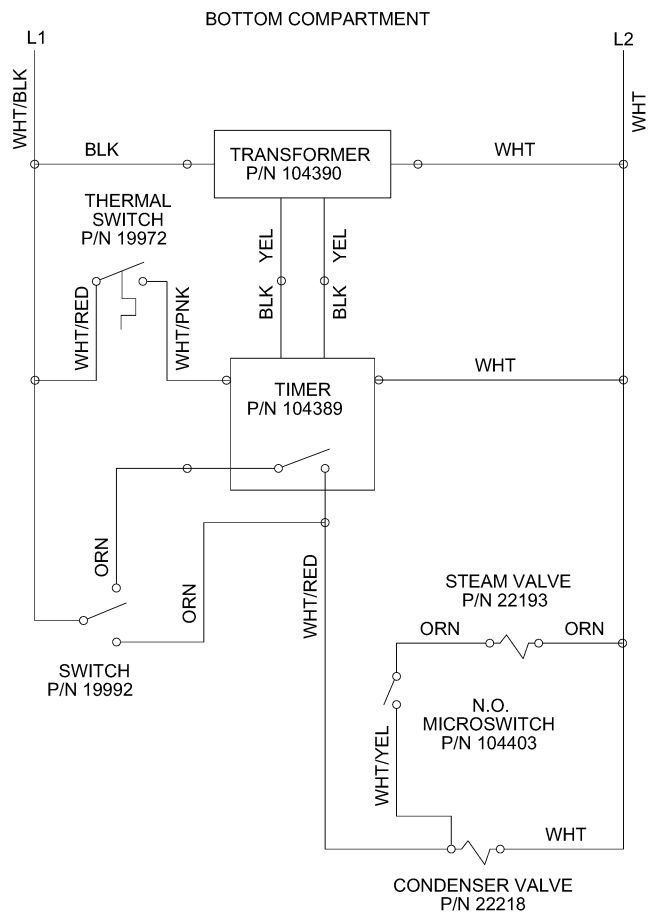
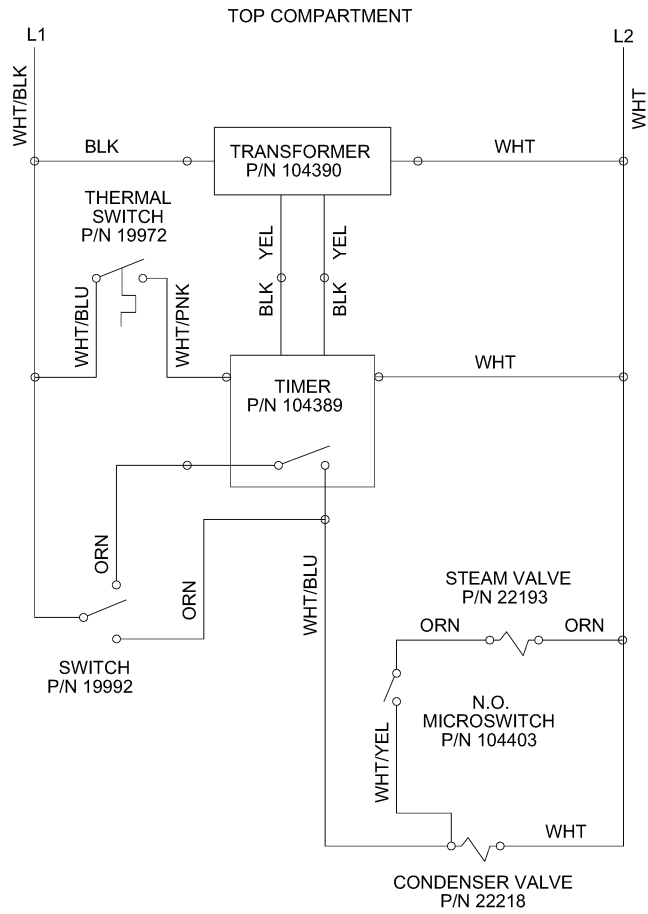

COMPLETE
WIRING
HARNESS
PT. NO.
106233

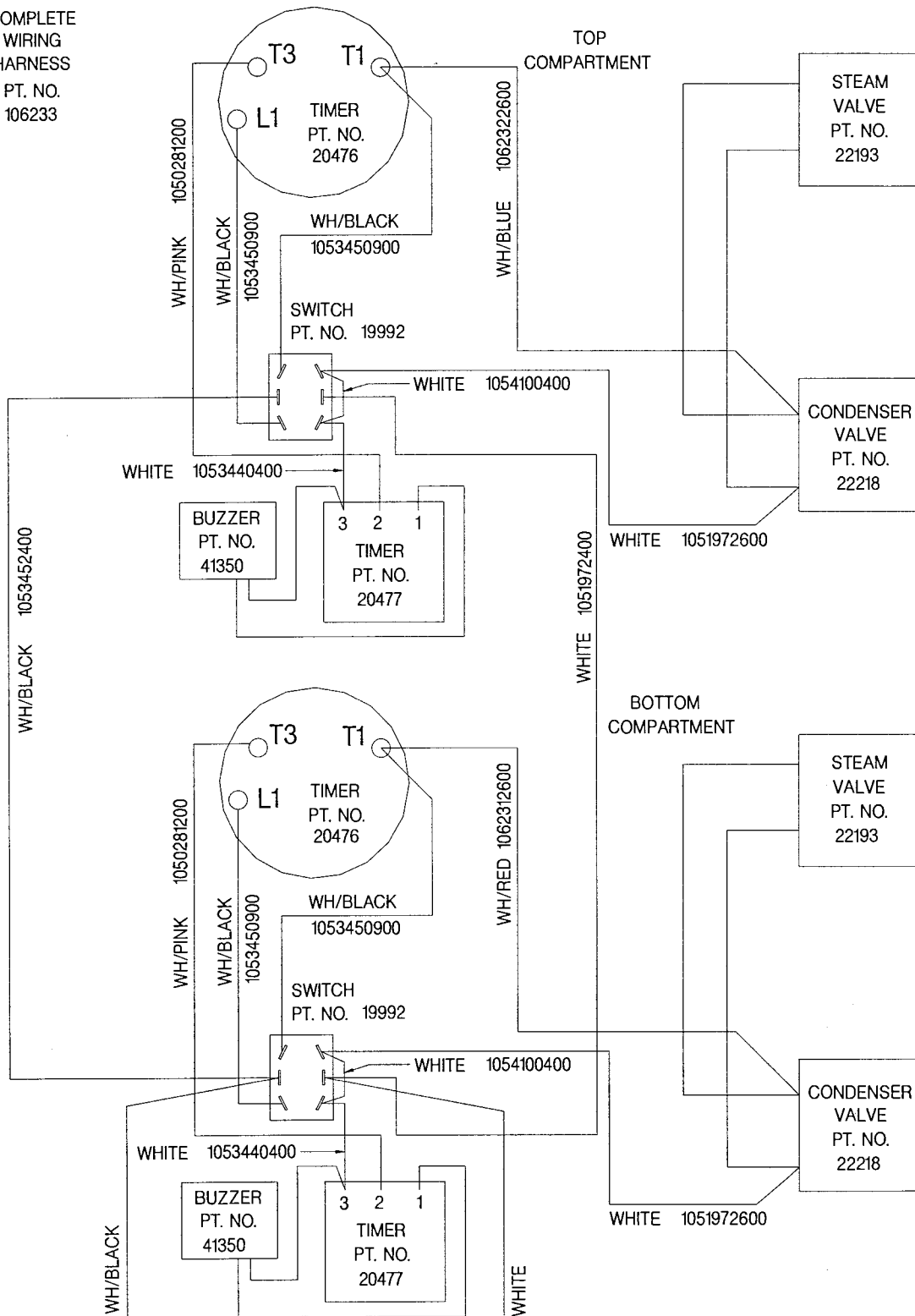

CONVECTION PRO XVI STEAMER - MECHANICAL TIMER
WIRING SCHEMATIC C-1043982

GAUGE PRESSURE	TEMPERATURE DEG. F.	HEAT IN BTU PER LB.		
		SENSIBLE	LATENT	TOTAL
0	212	180	970	1150
2	219	187	966	1153
4	224	192	962	1154
5	227	195	960	1155
7	232	200	957	1157
10	239	207	953	1160
12	244	212	949	1161
14	248	216	947	1163
15	250	218	946	1164
20	259	227	939	1166
25	267	234	934	1168
30	274	243	929	1172
35	281	250	924	1174
40	286	256	920	1176
45	292	261	916	1177
50	298	267	912	1179

Project _____
 Item _____
 Quantity _____
 FCSI Section _____
 Approval _____
 Date _____

PRESSURE STEAMERS

2 OR 3 COMPARTMENTS, GAS FIRED STEAM GENERATOR
 200 OR 300M BTU, 36" WIDE CABINET BASE
 with NICKELGUARD™

Cleveland Standard Features

- 5 psi Operating Pressure in cooking compartments
- Mechanical interlock prevents unlatching door while compartment is pressurized
- Timers, one per compartment, are mechanical style with audible signal
- Thermostatic Trap vents cooking compartment automatically
- Steam Inlet Valves and Exhaust Valves interlocked for synchronous action
- 8 psi Compartment Safety Valve
- Capacity per compartment for eight, 12" x 20" x 2 1/2" deep Cafeteria Pans, or four, 18" x 26" Bun Pans
- Heavy Duty, free floating, cast aluminum compartment doors
- Compartment Door Hinges have adjustable hinge pins and self-lubricating bushings
- Door Gasket replaceable without tools
- Pressure Gauge for compartment Operating Pressure
- Compartment Slide Racks are removable without tools, for easy cleaning
- Type 430 Stainless Steel: external enclosure, Table Top and eight gauge plate cooking compartments
- Modular Cabinet Base with Hinged Doors
- High efficiency Gas-Fired Steam Generator with NickelGard and Automatic Water Fill on start-up
- Automatic Water Level Control System with Low Water Power Cut-off Circuit
- Steam Generator equipped with High-limit Pressure Safety Switch and Safety Valve
- Automatic Steam Generator (boiler) Blowdown allows intermittent control, complete with additional Manual Drain Valve
- Steam Generator with Electronic Spark Ignition
- Single Cold Water Connection (no hot water required)
- 6" Stainless Steel Legs with level adjustment and flanged feet
- Gas Pressure Regulator and Control Valve
- Standard Voltage 115 volts, 60 hz, single phase
- All Major Components are serviceable from the front of unit
- Secondary Low Water Cut-Off, factory installed (CALG)
(Required for AZ. AR. CA. CO. CT. DE. FL. GA. HI. IL. IA. KS. MD. MA. MI. MN. MT. NE. NV. NM. NC. OK. OR. PR. RI. TN. UT. VA. WA. WV., Buffalo, NY, Wash. DC)

Options & Accessories

- Automatic Steam Inlet and Exhaust Operation (AT-2): includes 60 minute Automatic Timers and Manual Bypass

- MODELS:** 2 Compartments 3 Compartments
- PGM-200-2 PGM-200-3
- PGM-300-2 PGM-300-3



Short Form Specifications

Shall be _____ Compartments, CLEVELAND, Pressure Steamer, Model PGM-_____ - _____, Gas-fired Steam Generator, _____ M BTU input; _____ volts, single phase. Each Cooking Compartment equipped with: 60 Minute Timer; Pressure Safety Valve; Heavy-duty, free floating Door with Safety Interlock; and synchronous operating Steam Inlet and Exhaust/Drain Valves. Solid State Controls operate Water Level and Steam Generator (boiler) Safety Functions. Automatic Steam Generator (boiler) Blowdown with additional Manual Drain Valve.

- 15 psi for Kettle Operation, includes Power Take-Off (PTO)
- Kettle Interconnecting Kit (IMK)
- Stainless Steel Insulated Flue (SSF)
- Special Compartment Slide Racks
- Stainless Steel base Frame (FSS)
- 12" x 20" Cafeteria Pans 1", 2 1/2", 4" or 6" deep
- Intermediate Pull-Out Shelf (POS)
- Spray Head with flexible Hose (SH)
- Gas Option, other than natural
- Water Filters
- Rear Gas Connection (RGT)
- Correctional Packages

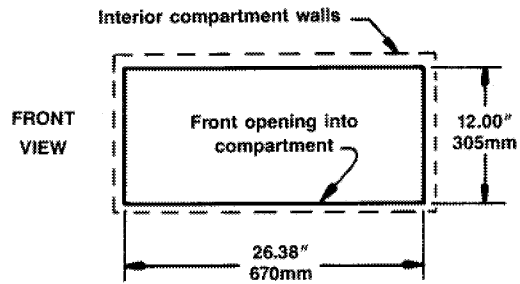
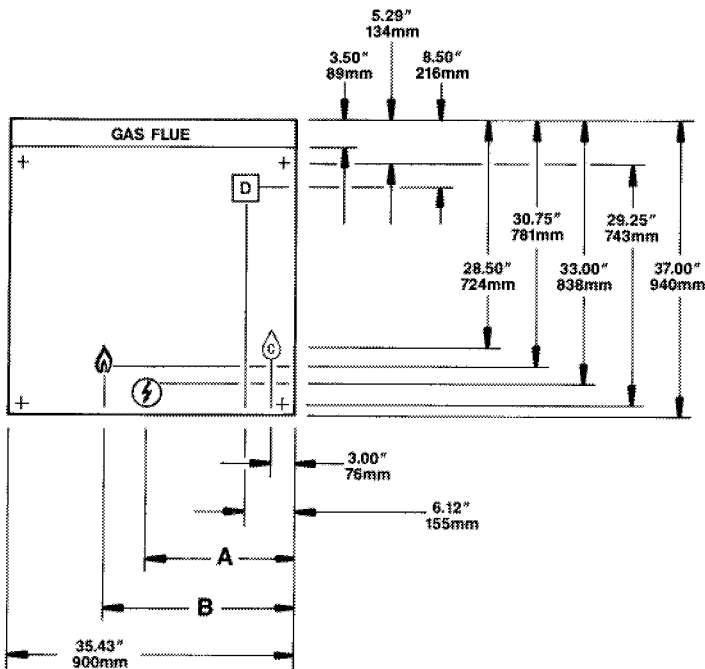

- Each compartment has capacity for:
 - Eight, 12" x 20" x 2½" Cafeteria Pans or
 - Six, 12" x 20" x 4" Cafeteria Pans or
 - Four, 12" x 20" x 6" Cafeteria Pans or
 - Four, 18" x 26" Bun Pans
- Many regional, state and local codes exist and it is the responsibility of the owner and installer to comply with those codes.
- Cleveland Range equipment is built to comply with applicable standards for manufacturers. Included among those approval agencies are: ASME/N.Bd., NSF, CSA (AGA, CGA).

WATER QUALITY REQUIREMENT

The recommended minimum water quality standards whether untreated or pre-treated, based upon 10 hours of use per day, and a Daily Blowdown, are as follows:

TOTAL DISSOLVED SOLIDS	less than 60 parts per million
TOTAL ALKALINITY	less than 20 parts per million
SILICA	less than 13 parts per million
pH FACTOR	greater than 7.5
CHLORINE	less than 30 parts per million

Consult a local water treatment specialist for an on site water analysis for recommendations concerning steam generator feed water treatment (if required), in order to remove or reduce harmful concentrations of minerals. The use of highly mineralized water will mean that more frequent servicing of the steam generator will be necessary. The fact that a water supply is potable is not proof that it will be suitable for the generator.

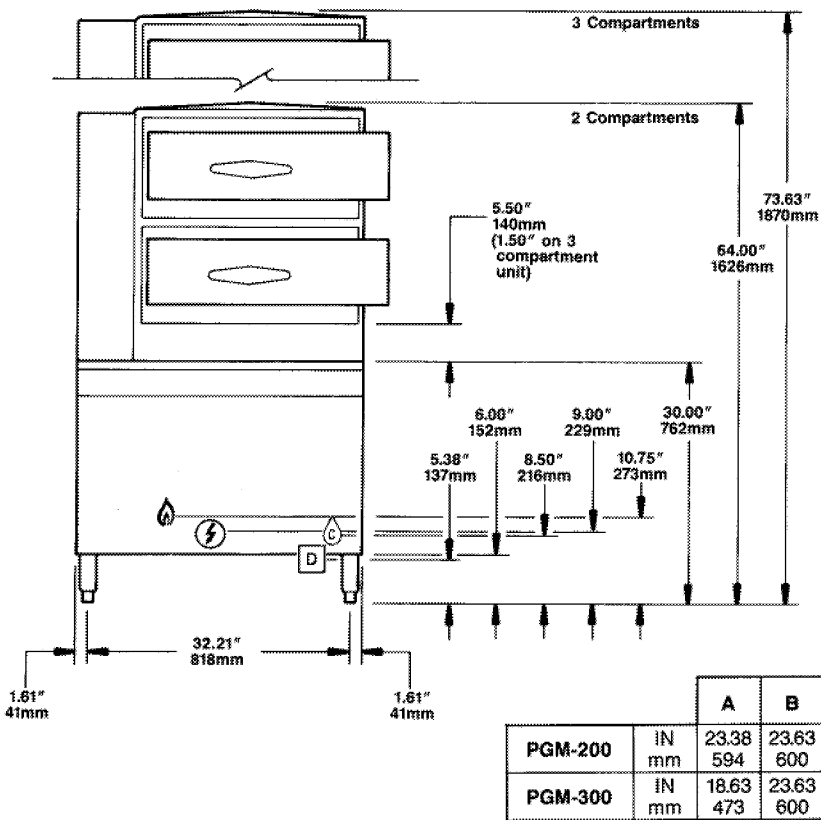

		A	B
PGM-200	IN	23.38	23.63
	mm	594	600
PGM-300	IN	18.63	23.63
	mm	473	600

GAS		ELECTRIC	WATER	DRAINAGE	CLEARANCE
NATURAL	PROPANE	115V - 1 PH	¼" NPT Cold Water Inlet	The Floor Drain must be located outside the confines of the equipment.	Right - 6", Left - 6", Rear - 6" (12" on control side if adjoining wall or equipment is over 30" high for service access)
¾" IPS for 220,000 BTU or less. 1.00" IPS for 250,000 BTU or more.	¾" IPS for 220,000 BTU or less. 1.00" IPS for 250,000 BTU or more.	25 watts per compartment	35 psi minimum	1 1/2" IPS common drain.	For use in non-combustible locations.
Supply pressure: 4.00" W.C. minimum 14.00" W.C. maximum	Supply pressure: 12.00" W.C. minimum 14.00" W.C. maximum	50 watts for Steam Generator Control	60 psi maximum	Do not connect other units to this drain.	Contact factory for variances to clearances.
Manufacturer must be notified if unit will be used above 2,000 ft. altitude.		5.0 Amps	Boiler feed	Do not use PVC pipe for drain.	
		** Do not connect to GFI outlet. See note below.			

NOTES:

**DO NOT CONNECT TO GFI OUTLET. CLEVELAND RANGE RECOMMENDS GAS FIRED 120 VOLT STEAMERS BE HARD WIRED DIRECTLY TO ELECTRICAL SYSTEM.

Cleveland Range reserves right of design improvement or modification, as warranted.

Many regional, state and local codes exist and it is the responsibility of the owner and installer to comply with the codes.

Cleveland Range equipment is built to comply with applicable standards for manufacturers. Included among those approval agencies are ASME/N. Bd, UL, NSF and CSA (AGA, CGA).

(NOT TO SCALE)

SECT. VI PAGE 4

0609

Litho in U.S.A.

ANTI-FLEX BRACE INSTALLATION PART NUMBER 100179

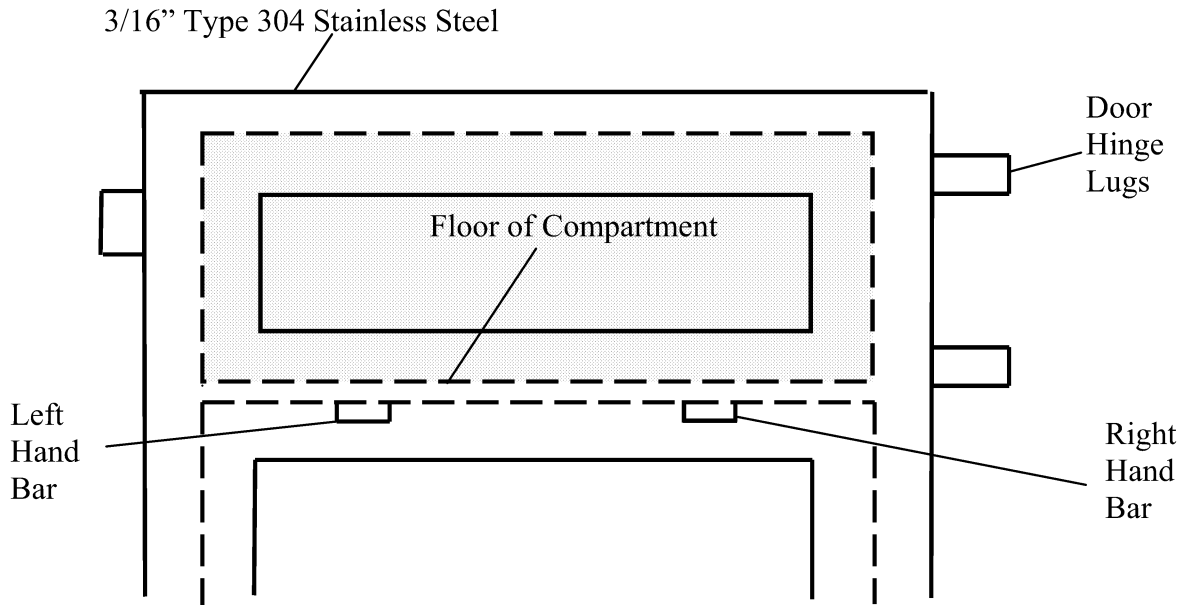

Welding rod type (recommended): 5/32" diameter, type 308 Stainless Steel

- 1). Position L.H. brace to underside of partition with retaining bar – **9" from left side.**
- 2). Tack weld at 2" intervals- brace to partition.
- 3). Remove retaining bar and position R.H. brace 9" from right, (hinged) side- same as #1.
- 4). Tack weld at 2" intervals – brace to partition.
- 5). Weld (single pass) low point of partition to brace with 2-3" long bead.
- 6). Remove flux and wire brush weld bead thoroughly to prevent loose scale from falling into food.

9/26/78

260AWI REV.A

SteamPro XVI® PRESSURE/CONVECTION STEAMERS

LARGE COMPARTMENTS, HIGH VOLUME
 DIRECT STEAM
 36" WIDE CABINET BASE DESIGN

MODEL: 36-PCDM

Cleveland Standard Features

- Cooking Capacity for up to eight 12" x 20" x 2½" deep Cafeteria Pans per compartment or four 18" x 26" Bun Pans.
- Each compartment can operate independently as a Pressure Steamer, or as a Convection Steamer, user selectable.
- **In the Convection Mode;** Pressureless cooking with convection steam, permitting doors to be opened while cooking continues.
- **In the Pressure Mode;** Door is locked and sealed, compartment operates at 5 psi steam pressure
- Each compartment is equipped with a 60 minute mechanical timer, separate bypass switch for constant steaming and a cold water condenser for superior cooking results (Convection only).
- **Durable 10 Gauge Stainless Steel Construction:** For Compartment Door and Steam Cooking Cavity
- **Separate Main Power Switch for "On/Off"**
- **Exclusive Steam Cooking Distribution System:** The Exclusive Convection Jets produce a high velocity convection steam without fans. Coved Corner design in cooking compartment distributes heat evenly and is easy to keep clean. Creased bottom enhances drainage. Cold Water Condenser for each compartment maintains a dry steam. Fully insulated cooking compartment for thermal efficiency. Removable Stainless Steel Slide Racks for easy cleaning.
- **Heavy duty, one piece, solid compartment door design with replaceable door gasket.**
- **Left Hand Door Hinging:** Compartment Doors hinged left, control on the right.
- Modular Cabinet Base with Hinged Door.
- **Heavy duty Stainless Steel Base Frame**
- **Moisture Separator Trap for incoming steam**
- **Pressure Reducing Valve:** For 35-50 psi incoming steam pressure based on a ¾" steam line. (minimum size)
- **Single Cold Water Connection**
- **NSF Certified 6" Stainless Steel Legs** with adjustable flanged feet for a one inch level adjustment.
- Standard voltage for controls 115 volts, 60 Hz, single phase.
- All Controls are serviceable from the front.
- Compartment Door Steam Shut Off Switch.



Shown with optional Electronic Timer

Short Form Specifications

Shall be Two Compartments, CLEVELAND Pressure/Convection Steamer, Direct Steam, Model 36-PCDM. Pressure/Convection Modes to be selectable at user's option with no restrictions as to any combination of modes. Type 304 Stainless Steel cooking compartment. Insulated cooking compartments. One 60 minute Mechanical Timer with Touch Control per compartment. Audible and Visual Signals for cycle completion and steam shut-off. Separate visual indication for each operational mode.

Options & Accessories

- Electronic Timer with Compensating Load Feature. (ETC)
- Cafeteria pans in depths of 1", 2½", 4" and 6"
- 18" x 26" Bun Pans
- Voltages for controls other than standard
- Correctional Packages
- Second Pressure Reducing Valve for 50-120 psi steam pressure (PRV)
- Clean non-toxic, uncontaminated steam is required for all "Direct Steam" steamers

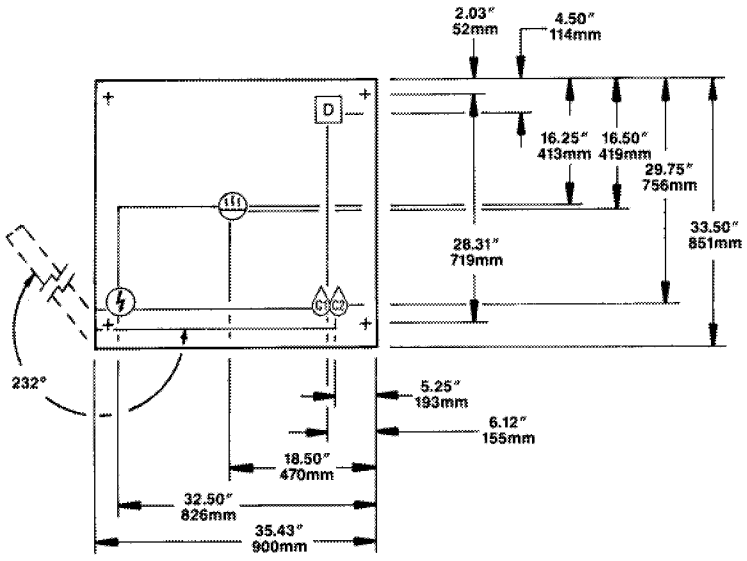

- Each compartment has capacity for: Eight, 12" x 20" x 2 1/2" deep Cafeteria Pans. Can accommodate four, 18" x 26" Bun Pans.
- Many regional, state and local codes exist and it is the responsibility of the owner and installer to comply with those codes.
- Cleveland Range equipment is built to comply with applicable standards for manufacturers. Included among those approval agencies are: UL, A.G.A., NSF, ASME/N.Bd., CSA, CGA, ETL, and others.

WATER QUALITY REQUIREMENT

The recommended minimum water quality standards whether untreated or pre-treated, based upon 10 hours of use per day, and a Daily Blowdown, are as follows:

TOTAL DISSOLVED SOLIDS	less than 60 parts per million
TOTAL ALKALINITY	less than 20 parts per million
SILICA	less than 13 parts per million
pH FACTOR	greater than 7.5
CHLORINE	less than 30 parts per million

Consult a local water treatment specialist for an on site water analysis for recommendations concerning steam generator feed water treatment (if required), in order to remove or reduce harmful concentrations of minerals. The use of highly mineralized water will mean that more frequent servicing of the steam generator will be necessary. The fact that a water supply is potable is not proof that it will be suitable for the generator.

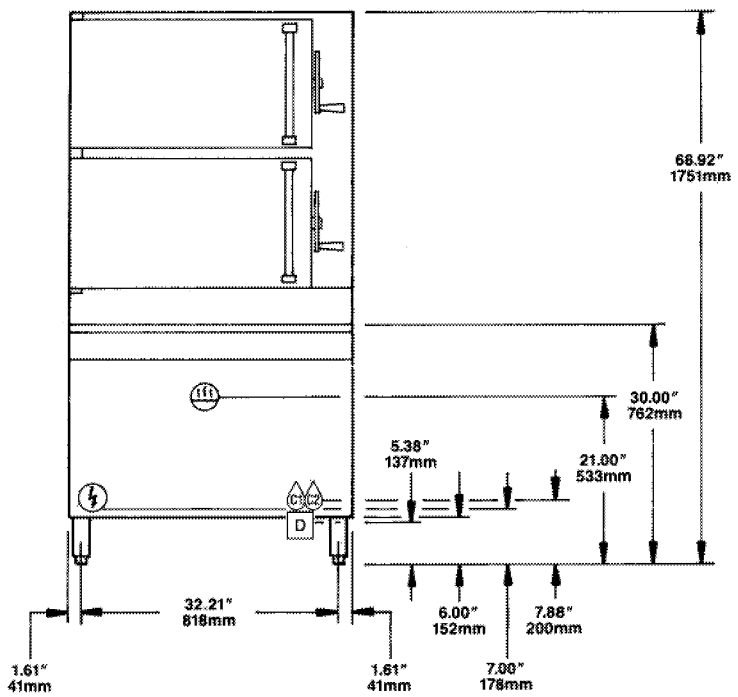

DIRECT STEAM (S)	WATER (C)	DRAINAGE (D)	ELECTRIC (E)	CLEARANCE
Steam Supply: Furnish 3/4" IPS minimum line. 35 psi minimum pressure required. For pressures above 50 psi, an additional Pressure Reducing Valve must be specified.	35 psi minimum 60 psi maximum cold water 3/8" NPT Condenser feed	1 1/2" IPS common drain. Do not connect other units to this drain. Do not use PVC pipe for drain.	115V-1PH 25 watts per compartment.	Right - 3", Left - 3", Rear - 3" (12" on control side if adjoining wall or equipment is over 30" high for service access) Contact factory for variances to clearances.

NOTES:
 Cleveland Range reserves right of design improvement or modification, as warranted.
 Many regional, state and local codes exist and it is the responsibility of the owner and installer to comply with the codes.
 Cleveland Range equipment is built to comply with applicable standards for manufacturers. Included among those approval agencies are UL, UL/NSF#4 and CSA.

CLEVELAND RANGE 36PCGM300
SEQUENCE OF OPERATIONS
Cooking Cabinets
With Electronic Timer

1. 115 VAC is sent to the primary of the 24 VAC timer transformer and the time/manual switch.
 - 115 VAC is also sent to the normal open contacts of the thermal switch.
 - 24 VAC is sent to the timer.
2. When the time/manual switch is in the timed position 115 VAC is sent to the contacts of the timer.
 - When time is on the electronic timer the contacts will close and the timer will display “PAUS”.
 - 115 VAC is sent to the convection/pressure switch.
 - When the thermal switch closes at 193 degrees the timer begins to count down.
 - When the timer counts to zero the contacts open and a buzzer sounds.
3. When the time/manual switch is in the manual position the timer contacts are bypassed and 115 VAC is sent directly to the convection/pressure switch.
4. When the convection/pressure switch is in the convection position:
 - 115 VAC is sent to the normally open contacts of the arm lock micro switch.
 - When the door is closed and the arm lock in the down position the micro switch closes.
 - 115 VAC is sent to the steam solenoid and it opens sending steam to the cooking cabinet.
 - 115 VAC is sent through the normally closed contacts of the relay to the condensate solenoid sending water to the condensate spray nozzles.
5. When the convection/pressure switch is in the pressure position:
 - 115 VAC is sent to the lock solenoid locking the door closed.
 - 115 VAC is sent to the coil of the relay.
 - The relay is energized and the normally closed contacts to the condensate solenoid open.
 - The normally open contacts to the 3-way solenoid close.
 - 115 VAC is also sent to the normally open contacts of the arm lock micro switch.
 - With the door closed and the arm lock in the down position, both the micro switches are closed.
 - 115 VAC is sent to the steam valve and it opens sending steam into the cabinet.
 - 115 VAC is then sent to the 3-way solenoid energizing it.
 - Water is sent to the flow regulator causing it to back up into the Pinch valve.
 - The bladder in the pinch valve swells closing the drain.
 - Pressure builds in the cabinet and the steam-plunger lock solenoid.
 - This locks the door until no pressure is in the cabinet.

STEAM PRO - ELECTRONIC TIMER

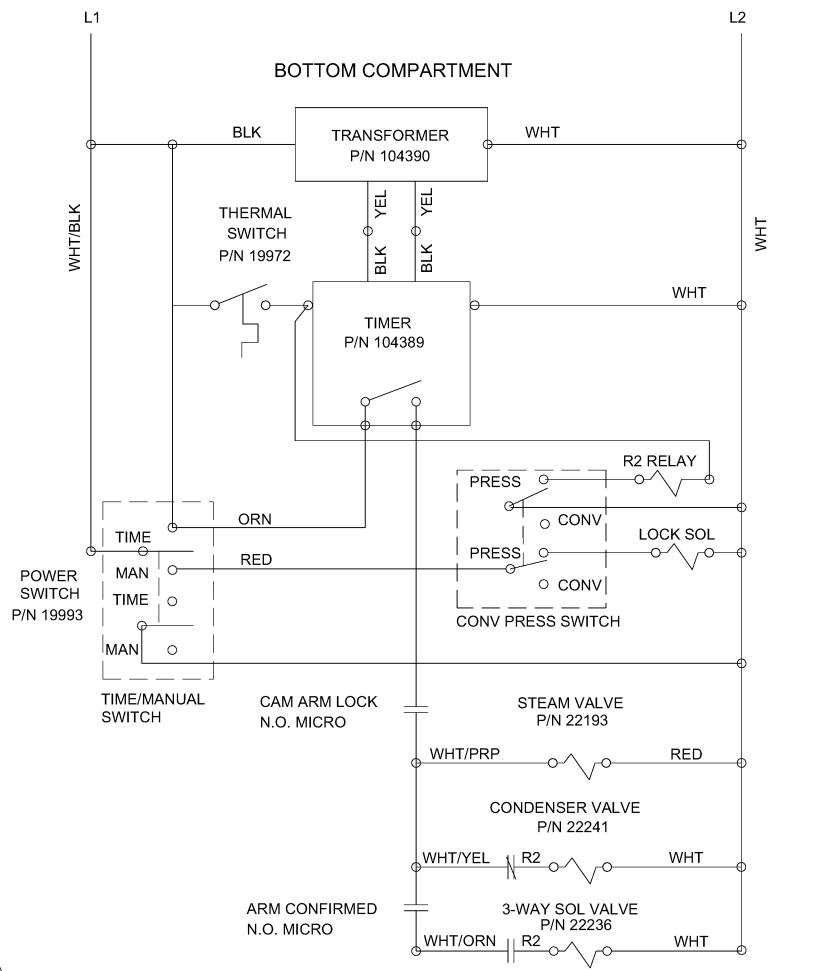
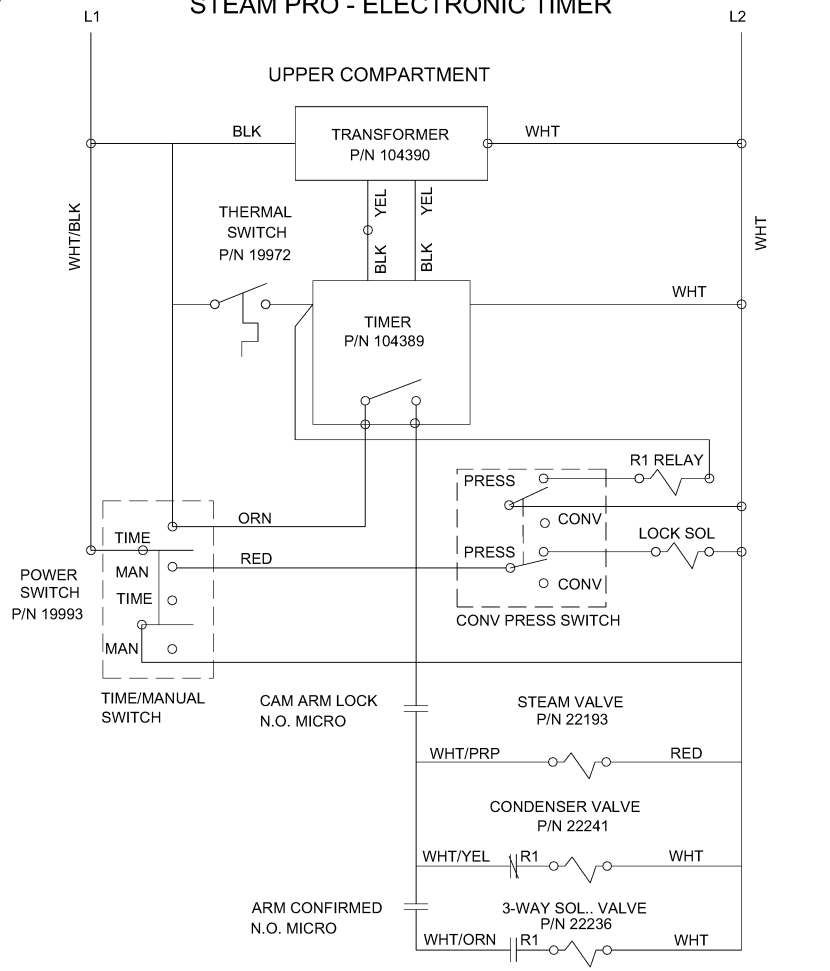

CLEVELAND RANGE 36PCGM300
SEQUENCE OF OPERATIONS
Cooking Cabinets
With Mechanical Timer

1. 115 VAC is sent to pressure/convection switch.
2. When the convection/pressure switch is in the convection position 115 VAC is sent to the timer. When time is on the timer:
 - 115 VAC is sent to the normally open contacts of the arm lock micro switch.
 - When the door is closed and the arm lock in the down position the micro switch closes.
 - 115 VAC is sent to the steam solenoid and it opens sending steam to the cooking cabinet.
 - 115 VAC is sent through the normally closed contacts of the relay to the condensate solenoid sending water to the condensate spray nozzles.
 - When the timer times down 115 VAC is sent energizing the 3-second timer.
 - The buzzer is energized for 3 seconds.
3. When the convection/pressure switch is in the pressure position and time on the timer:
 - 115 VAC is sent to the lock solenoid locking the door closed.
 - 115 VAC is sent to one side of the coil of the relay.
 - 115 VAC is also sent to the normally open contacts of the arm lock micro switch.
 - With the door closed and the arm lock in the down position, both the micro switches are closed.
 - 115 VAC is sent to the steam valve and it opens sending steam into the cabinet.
 - 115 VAC also goes through the normally closed contacts of the relay to the condensate solenoid.
 - When the cabinet heats to 192 degrees, the thermal switch closes and 115 VAC is sent to the other side of the relay coil.
 - The relay is energized and the normally closed contacts open turning off the condensate solenoid.
 - The normally open contacts of the relay close.
 - 115 VAC is then sent to the 3-way solenoid energizing it.
 - Water is sent to the flow regulator causing it to back up into the Pinch valve.
 - The bladder in the pinch valve swells closing the drain.
 - Pressure builds in the cabinet and the steam-plunger lock solenoid.
 - This locks the door until no pressure is in the cabinet.
4. When the cabinet timer is done and 115 VAC is removed from the 3-way solenoid the water is removed from the pinch valve through the flow regulator opening the cabinet drain.
 - Pressure is removed from the cabinet and the steam-plunger solenoid releases and the door can be opened.
 - 115 VAC is sent to the 3-second timer.
 - The buzzer is energized for 3 seconds.

TOP COMPARTMENT

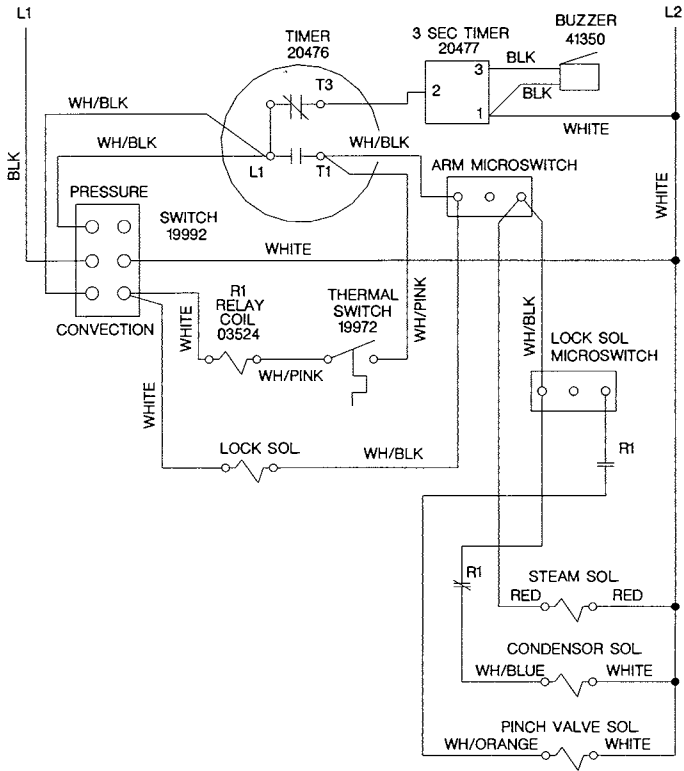

BOTTOM COMPARTMENT

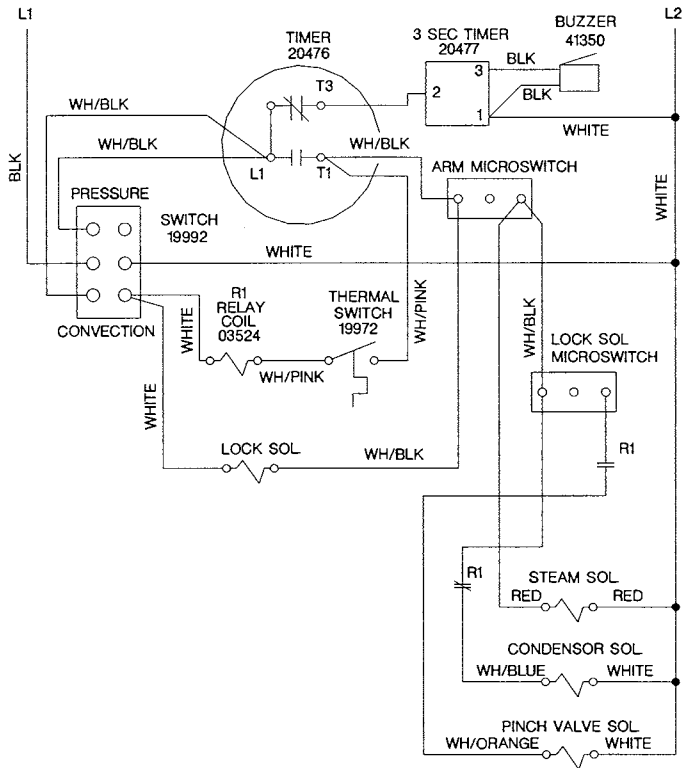

11.000

STEAM PRO - MANUAL CONTROLS C-104967

