



# TIPPER TIE®

A **DOVER** COMPANY

P.O. BOX 866 LUFKIN ROAD  
APEX, N.C. USA 27539-0866  
(919) 362-8811 or 1-800-331-2905  
FAX: (919) 362-8667

**Clipper Manual  
Model SZ4135L**

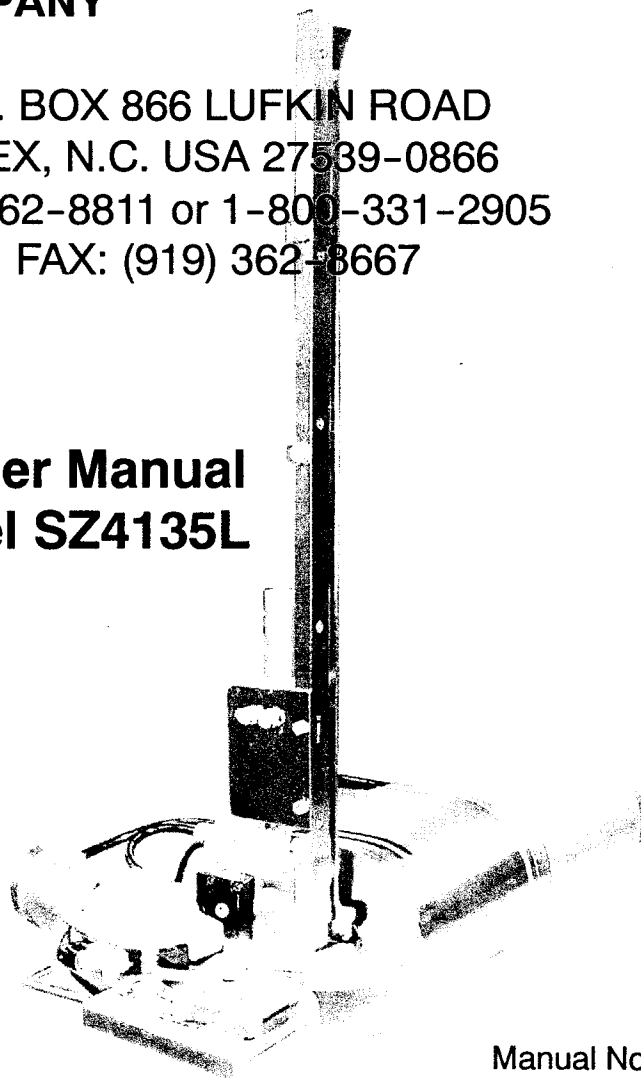

Manual No. 80-1302  
Revision No. 00  
(11/19/2002)

# Tipper Tie Models SZ4135L

## Table of Contents

<b>Tipper Tie Warranty:</b> .....	5
<b>Chapter 1: Machine Description and Specifications</b>	
1.1 Description .....	6
1.2 Applications .....	6
1.3 Machine specifications .....	7
<b>Chapter 2: Safety Instructions</b>	
2.1 International Safety signs .....	8-9
2.2 Safety Instructions .....	10-11
2.3 Danger Areas .....	12
2.4 Sound levels .....	13
<b>Chapter 3: Delivery and Inspection</b>	
3.1 Delivery and inspection .....	14
3.2 Unpacking equipment .....	14
<b>Chapter 4: Air Connections and Lubrication</b>	
4.1 Installation of Main Air Supply .....	15
4.2 Filter / Regulator / Lubricator .....	15
4.3 Air regulator Assembly .....	16
4.4 Lubricator Adjustment .....	17
4.5 Regulator Adjustment .....	18
<b>Chapter 5: Operating instructions</b>	
5.1 Preparation .....	19
5.2 Operating machine .....	19
5.3 Punch Assembly Procedure .....	20
5.4 Mechanical Crimp control .....	21
5.5 Clipper cycle .....	22
<b>Chapter 6: Cleaning Procedure</b>	
6.1 U.S. Department of Agriculture Guidelines .....	23-24
6.2 Cleaning Procedure .....	25
<b>Chapter 7: Maintenance</b>	
7.1 General maintenance Checklist .....	26
7.2 Lubricator Maintenance .....	27
7.3 Filter / Regulator Maintenance .....	27

**Chapter 8 Trouble Shooting Guide** ..... 28

**Chapter 9: Spare Parts List**

9.1 Recommended Spare Parts ..... 29

9.2 Loose Parts List ..... 29

**Chapter 10:Assembly drawings** ..... 30

## TERMS AND CONDITIONS

Tipper Tie, Inc. and the customer named on the reverse side of 1st page hereof ("Customer") agree the following terms and conditions shall govern the delivery and installation of the equipment ("Equipment") set forth on the reverse side or 1st page hereof.

**1.A Warranty. Limitation of Liability.** Tipper Tie, Inc. warrants the Equipment will, upon delivery to Customer, conform to the description and specifications set forth herein and will be free from defects in material and workmanship. Tipper Tie, Inc. shall repair or replace, at their option, any part or parts comprising the Equipment which become defective during the (i) six-month period following the delivery of the Equipment to the Customer's plant location, or (ii) the period ending when the equipment has run the number of Machine Cycles as specified on Addendum A attached hereto for the particular model of equipment purchased by the Customer. The repair or replacement of parts shall occur within a commercially reasonable period following receipt of a declaration from the Customer. Items, components, or parts not conforming to the forgoing warranty, shall be returned to Tipper Tie, Inc., f.o.b. Apex, North Carolina. All items, components, or parts replaced by Tipper Tie, Inc. shall become the property of Tipper Tie, Inc. The warranty becomes immediately void in every case where repairs affecting machine operation or safety are compromised, modifications or alterations are carried out by the Purchaser or by third parties, without the prior written consent of Tipper Tie. The warranty does not cover damages caused by insufficient, incorrect or forceful operation of the equipment, failure to observe the operating instructions, overloading, the use of materials, consumables or accessories not manufactured by Tipper Tie or specifically approved in writing by Tipper Tie for use with the equipment, chemical or electrolytic action, the use of spare parts from an outside source, or any event of force majeure.

**1.B** Tipper Tie makes no warranties for damages resulting from normal or excessive wear of component parts to include, but not be limited to, punches, dies, knife blades, skin brakes, or conveyor belts and other parts which by their nature as a result of normal equipment operation wear out and must be replaced. Tipper Tie makes no warranties as to any equipment or accessories not manufactured by Tipper Tie, and Purchaser shall be limited only to the warranties, if any, provided by the manufacturer of such equipment or accessories. Any declaration made under this warranty must be presented, in writing, to Tipper Tie during the Warranty Period.

**1.C** In addition, either the Customer or Tipper Tie, Inc. may terminate this agreement at any time during the two week period following the date the Equipment is first installed and operable if Customer is not satisfied the Equipment conforms to the description and specifications set forth herein and Tipper Tie, Inc. states they unable to cure such alleged defect. In such event and no later than ten days following said two week period, Customer shall at Customer's expense, clean, sanitize, render chemically inert any cleaning solution, crate and deliver (freight prepaid) the equipment to Tipper Tie, Inc., Apex, North Carolina. All risk of loss and damage to the Equipment (while at Customer's plant and while in transit) shall be borne by Customer until delivery to Tipper Tie, Inc. If the Equipment is not delivered to Tipper Tie, Inc. within the period and physical condition stated above, the Equipment shall be deemed accepted by Customer and to conform to such description and specifications. The cost of any parts or components not returned shall be borne by the Customer. Tipper Tie, Inc. will not be liable for personal injury or property damage nor shall it have obligations or liabilities for consequential damages including but not limited to product loss, film loss and lost profits even if advised of the possibility of such. **THE FOREGOING WARRANTY IS IN LIEU OF ALL OTHER WARRANTIES, EXPRESS OR IMPLIED, INCLUDING BUT NOT LIMITED TO, THE IMPLIED WARRANTIES OF MERCHANTABILITY AND FITNESS FOR A PARTICULAR PURPOSE.** Customer further agrees that Tipper Tie, Inc.'s liability hereunder for damages including but not limited to patent and copyright infringement shall not exceed the aggregate sum paid hereunder by Customer to the date the amount of such liability is determined.

**2.A Implied Patent and Copyright License.** Customer is granted an implied license to practice the inventions and authored works of Tipper Tie incorporated in the Equipment which license is limited and does not include any unauthorized reconstruction of the Equipment. Unauthorized reconstruction shall constitute infringement for which Customer shall be liable pursuant to Title 35 and Title 17 of the United States Code (US Patent and Copyright Act), and shall be subject to injunction, and damages payment of all attorney fees and costs.

**2.B Patent and Copyright Indemnification.** If notified promptly in writing of any action brought against Customer, based on a claim that the Equipment infringes a United States Patent or copyright, Tipper Tie, Inc. will defend such action at its expense and will pay the costs and damages awarded in any such action, provided that Tipper Tie, Inc. shall have the sole control of the defense of any such action and all negotiations for its settlement or compromise. In the event that a final injunction shall be obtained against the Customer's use of the Equipment by reason of infringement of a United States patent or copyright, Tipper Tie, Inc. will, at its option and at its expense, either procure for the Customer the right to continue using the Equipment, replace or modify the same so that it becomes non-infringing, or grant Customer a credit for such Equipment as depreciated and accept its return. Customer shall hold Tipper Tie, Inc. harmless against any expense, judgment or loss for infringement of any patents or copyrights which result from Tipper Tie, Inc.'s compliance with Customer's designs, specifications, or any unauthorized reconstruction of Equipment.

**3. Security Interest.** Customer hereby grants Tipper Tie, Inc. a security interest in the Equipment and proceeds thereof, to secure Customer's obligation hereunder. Customer hereby appoints Tipper Tie, Inc. its attorney-in-fact to execute financing statements to perfect such security interest.

**4. General.** All obligations and warranties by Tipper Tie, Inc. granted hereunder are void in the event of any unauthorized reconstruction by or for Customer and any liabilities or claims of any nature whatsoever associated with the Equipment shall be assumed by Customer. If any of the provisions of this agreement are invalid under any applicable statute or rule of law, they are to that extent deemed omitted. The Customer's remedies in this agreement are exclusive. Any purchase order or similar form attached hereto is void to the extent that it contains any terms that are contrary to, or inconsistent with, the provisions of this contract. The parties agree that this agreement is the complete and exclusive statement of the understanding between the parties, which supersedes all proposals oral or written and all other communications between the parties relating to the subject matter of this agreement. This agreement will be governed by the laws of the State of North Carolina.

### ADDENDUM A

<u>Model Number</u>	<u>Cycles/Minute</u>	<u>Machine Cycles</u>	<u>Model Number</u>	<u>Cycles/Minute</u>	<u>Machine Cycles</u>
DKF 18/15	80	8,000,000	SAM3E	25	2,500,000
DKF 15/12	150	15,000,000	TB-15	15	1,500,000
DC 18/15	80	8,000,000	TCM 2250, pump	8	800,000
DC 15/12	150	15,000,000	TCM 2250, breech	5	500,000
RS4202M	14	1,400,000	PTM	17	1,700,000
RS4203	14	1,400,000	PTRFMx, normal	30	3,000,000
TC4353	15	1,500,000	PTRFMx, high speed	45	4,500,000

<u>Model Number</u>	<u>Cycles/Minute</u>	<u>Machine Hours</u>
HS3	8	2000
Rota-Clip	8	2000

### 1.3 Machine Specifications

**Air Consumption:** .7 cubic feet per cycle at 80 PSI, (19.81 Liters at 5,5 Bar)  
**Air Requirements:** 80-100 PSI, (5,5 - 6,9 Bar)  
**Clip size:** Z400 series stick clips  
**Machine weight:** 68 lbs. (30.6Kg.)  
**Shipping weight:** 75 lbs. (33.7Kg.)

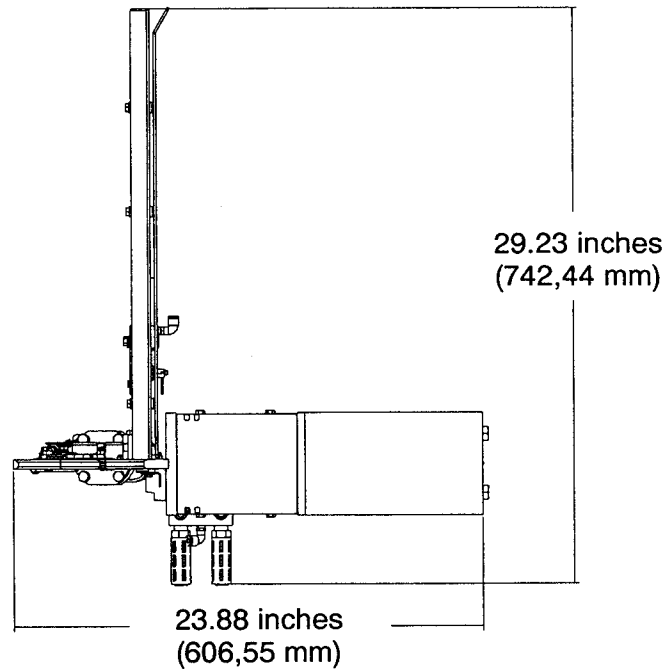
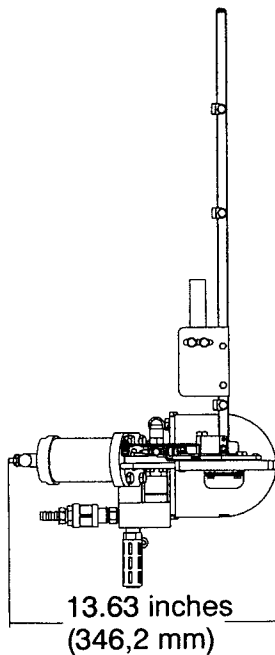
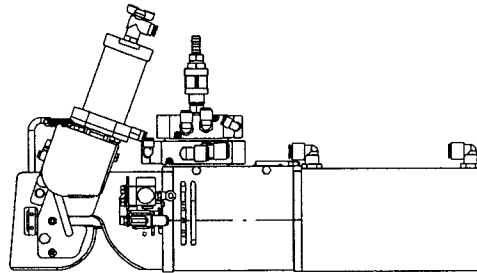

# **Chapter 1: Machine Description and Specifications**

## **1.1 Description**

The Tipper Tie Clipper, Model SZ4135L is a horizontally mounted clipper designed to apply a secure seal on a variety of packaging materials. For each clipper cycle, the machine will do the following:

- \* *Gather the neck of the bag*
- \* *Apply a secure leak proof seal*
- \* *Trim excess bag tail from product*

The clippers are designed to operate with all Tipper Tie Z400 series stick clips. Clip size is determined and selected on the basis of product or closure size. A Tipper Tie representative will gladly assist in determining the correct clip for the given application.

## **1.2 Applications**

The SZ4135L clipper is designed to provide one-step closing for a variety of food products, such as beef, poultry, cheeses, or a wide assortment of non-food products.

## Chapter 2: Safety Instructions

### 2.1 International Safety Signs

#### INTERNATIONAL SAFETY SIGNS USED TO COMMUNICATE HAZARD INFORMATION USED WITH APPROPRIATE MACHINE FUNCTIONS

- THE YELLOW TRIANGLE SIGNS WARN OF EXISTING HAZARDOUS CONDITIONS
- THE BLUE CIRCULAR SIGNS DEFINE MANDATORY ACTIONS REQUIRED

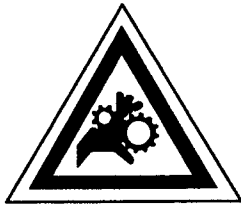

**WARNING: DANGER OF CRUSHING**



**WARNING: EXPLOSIVE ATMOSPHERE**



**WARNING: KEEP HANDS AWAY FROM PINCH AREA**

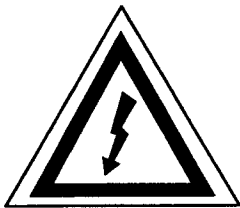

**WARNING: DANGEROUS ELECTRICAL CURRENT**



**WARNING: HOT SURFACE**



**WARNING: KEEP HANDS AWAY FROM KNIFE AREA**



**WARNING:**



**INSERT SAFETY LOCKOUT**



**CONSULT SERVICE MANUAL**



**ELECTRICAL LOCKOUT REQUIRED**

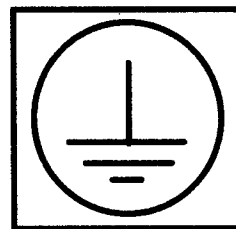

**PROTECTIVE EARTH GROUND**

## 2.1 International Safety Signs continued:



**WARNING:**

When using this machine, all operating instructions, safety instructions and precautions must be followed and strictly adhered!

Do not attempt to install, setup or operate this machine before you have read and understood this manual and any accompanying supplier's manuals.



Follow all warnings and safety instructions in this manual. Failure to comply with safety instructions could result in serious injury.



## 2.2 Safety Instructions

With the use of this machine, the following safety precautions must be obeyed:

- \* Before installing and first operating the machine, this manual must be read and understood. Follow all operating and safety instructions and exercise extreme care.
- \* This machine must be installed securely, and permanently attached to a solid surface before starting and operating.
- \* This machine must be operated only by trained personnel. Training must be repeated at regular intervals.
- \* Safety devices must be checked each day to ensure proper operation. Safety features should be examined once each year by experts.
- \* All guards, protective covers and shields must be in place before operating the machine. Do not modify, remove, disable or bypass the guards. Operating this machine with guards, covers and shields removed could result in serious injury. **Never operate this machine without safety devices.**
- \* **The maximum working pressure for this machine is 100 psi, (6,9 bars)**  
Air pressure greater than this could cause an explosive rupture in any of the air lines or pneumatic components. Failure to adhere to this caution could result in personal injury or damage to the machine.
- \* Keep hands and fingers clear of the punch, die and knife areas at all times. Never touch these areas while the machine is in operation. Do not allow fingers, hands, jewelry or clothes around moving parts during operation of this machine.

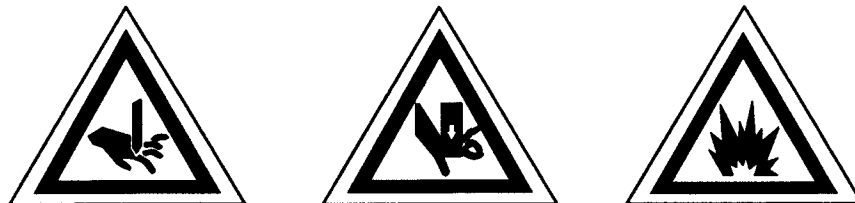

## 2.2 Safety Instructions continued:

- \* Immediately report any malfunction to the person in charge
- \* Stop machine to correct malfunctions.
- \* Disconnect air supply prior to servicing or moving the machine. The main air supply line must be disconnected from the machine before performing any service operation or maintenance.
- \* When this machine is not in operation, the air supply must be disconnected at the plant / regulator junction or at the quick disconnect on the machine. Failure to disconnect the air supply from this machine creates serious risk of injury. To prevent unauthorized personnel from operating this machine, secure the lock out valve in closed position. Attach a padlock through the holes.
- \* When moving the machine, keep hands and fingers clear of punch, die and knife areas.
- \* Use only original spare parts and accessories.
- \* If the machine is sold, the manual must be supplied to the new owner.

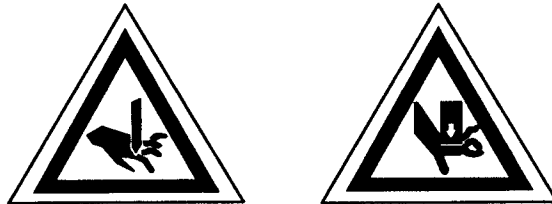

## 2.3 Danger areas

**Warning:**  
**Keep hands and fingers clear of die, punch, and knife areas.**

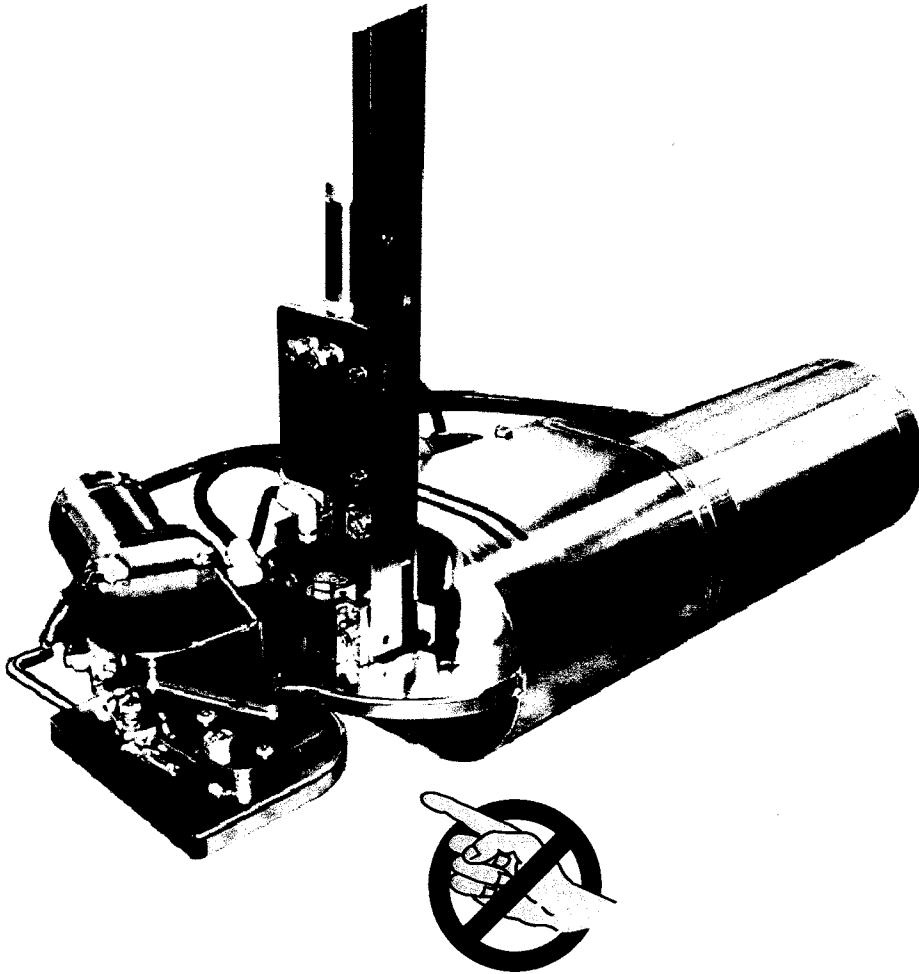

## **Chapter 2 Continued:**

### **2.4 Sound levels**

The sound and noise level tests were conducted under the European Norm Number 31201, Noise Emitted by Machinery & Equipment Standards for Emission of Both Peak & Continuous Sound Levels at a Work Station.

The tests were conducted for both continuous and peak noise levels. The following data are a result of the test:

#### **Continuous sound power level:**

"A" Weighted scale

1000 Hertz Frequency Range

Continuous Sound Levels were recorded at 72.8dB.

The standard indicated the 8 hours exposure level shall not exceed 85dB without hearing protection.

#### **Peak instantaneous sound pressure value:**

"C" Weighted scale

1000 Hertz Frequency Range

Peak instantaneous Sound Pressure Values were recorded at 86.4dB.

The standard indicates the Peak Instantaneous Sound Pressure Level Shall not exceed 130dB on the "C" weighted scale without hearing protection.

The sound tests were conducted as specified in the standard, from a height of 1.6 meters from the floor and 1/2 meter from the machine. This test location simulated the distance an operator would be standing in relation to the machine and at the hearing height of an average person.

## **Chapter 3: Delivery and Inspection**

### **3.1 Delivery**

Upon delivery, inspect the shipping container and equipment for damages due to shipping and handling. If damage is found or suspected, contact the shipping agent immediately. In order that the carrier may have an opportunity to inspect goods and thereby properly verify claims, any loss or damage discovered after delivery should be reported to the agent of the delivering line immediately or within 15 days after receipt of goods.

In many instances, the original container is not opened and the contents not examined before reshipment to final destination. Therefore, under (SUBPART C: CLAIMS FOR LOSS OR DAMAGE: SECTION 1226.200 NATIONAL MOTOR FREIGHT CLASSIFICATION), 9 months are allowed for filing claims for loss or damages.

The shipping agent or carrier will help you in processing your claim. Remember to report all suspected damages immediately. If additional assistance is required, TIPPER TIE will gladly help in settling your claim. However, first contact the carrier or his agent involved.

WITH ALL CORRESPONDENCE, INCLUDE THE FOLLOWING:

- \* Original bill of lading or copy thereof. \*
- \* Vendor invoice, or certified copy, when claim is based on weight or valuation of shipment has been improperly described.
- \* Catalog pages or product information.
- \* Original packing slip or receiving reports.
  - \* or copy of electronic bill of lading manifest.

### **3.2 Unpacking Equipment**

For ease of shipping, partial disassembly of the machine sometimes is necessary. Check the shipping list and loose parts list to ensure that all items have been received. Do not discard packing materials until machine is assembled and operation. notify **Tipper Tie** immediately if any component is missing or if additional assistance is required.

Refer to the installation and operating instructions before starting to operate the equipment. Add all required oils and fluids, and make all machine adjustments as instructed before starting machine. Failure to do so may result in equipment damage or personal injury, and voids product warranty.

## **Chapter 4: Air Connections and Lubrication**

### **4.1 Installation of Main Air Supply**

Recommended clipper working pressure setting is 80–100 psi (5,5–6,9 bar). Before operating, check clipper air line connections as set at factory. If lines have become disconnected, reassemble as shown per pneumatic schematic. Air pressure can be regulated from the air regulator assembly. The air regulator assembly consists of filter, regulator, and oiler. Please note incoming air direction. (plant air flow)

Assemble the factory air supply to the air regulator assembly by means of the quick-disconnect, connector. This quick-disconnect provides a means of removing the air supply for servicing and clean-up. The quick-disconnect must be attached with the check valve half (female), to the supply side of the air circuit.

### **4.2 Filter / Regulator / Lubricator**

The filter must be kept clean to maintain maximum filtering efficiency. Open drain cock, under the filter periodically and drain off any bowl accumulation before it reaches level of lower baffle. A visible coating of dirt or condensate on the filter element surface or an excessive pressure drop is an indication that cleaning is necessary. To clean, turn-off air supply, and depressurize. Loosen locking collar and remove bowl. Clean all parts with denatured alcohol and blow-out the inside with compressed air.

### 4.3 Filter, Regulator, Lubricator Assembly, (FRL)

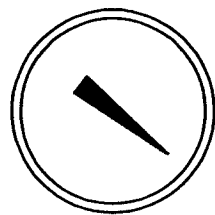
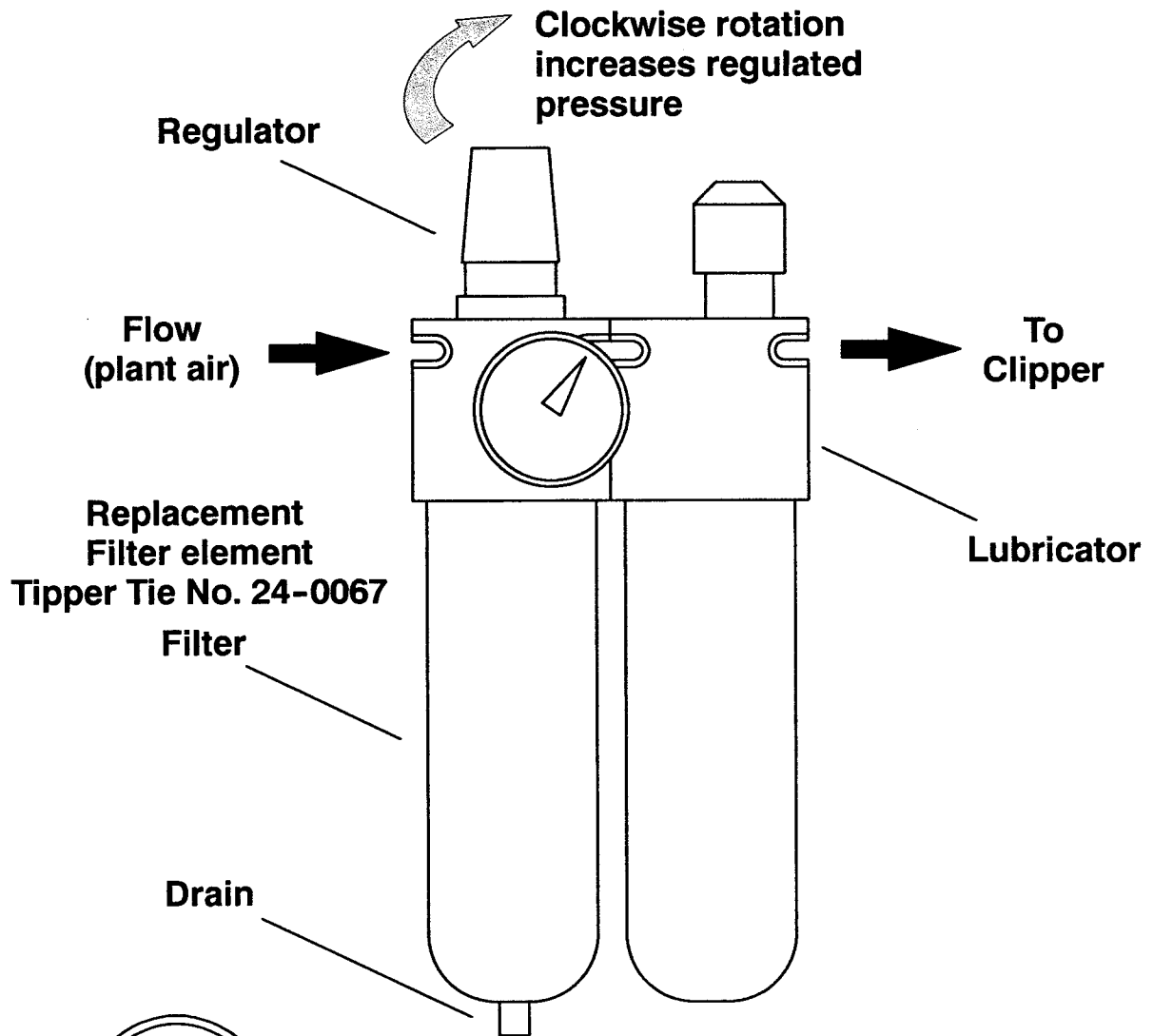

**Recommended Pressure Setting:  
80-100 psi (5,5-6,9 bar)**



**Warning:  
Do not set air pressure  
above 100 psi, (6,9 bar)**

## 4.4 Lubricator Adjustment



**Do not attempt to add oil to the lubricator while under pressure. Disconnect the air pressure supply and purge pressure from the system before filling with lubrication fluids.**

**The lubricator cannot be filled while under pressure.**

### **LUBRICATION:**

For average operating conditions, the use of SAE #10 (SUV > 150-200 SEC @100 degrees F) oil is recommended. Other lubrications may be used if not heavier than SAE #40 (SUV 800 SEC @ 100 degrees F).

### **FILLING:**

Shut down and depressurize before refilling lubricator. Slowly remove the fill plug and fill to 1/4 inch to the top of the bowl using recommended oil.

### **ADJUSTMENT:**

The adjustment knob is calibrated from "0" to "9". At "0" no oil is delivered, the unit is not lubricating. To adjust, first turn on the air. Turn the knob to start oil flow, observing the drip rate visible through the sight glass. One to two drops per minute is suggested, correct lubrication being a matter of experience and demand. *Counter-clockwise rotation of knob increases oil feed rate.*

To check lubrication, hold a mirror of similar material near the equipment exhaust. A heavy film discharge indicates over-lubrication. The oil drop rate should be reduced by turning the knob to a lower setting, decreasing oil drop rate.

If no oil drips through the sight glass with the needle valve open, proceed as follows:

- \* Make certain there is sufficient oil in the bowl.
- \* Check to determine whether there is air pressure ahead of the lubricator.
- \* Check the air flow from the lubricator.

If oil still does not drip through the sight glass, an accumulation of dirt in the lubricator is indicated. The lubricator will need to be cleaned.

## 4.5 Air regulator adjustment



**It is recommended that air pressure remain between 80 - 100 psi (5,5- 6,9 bar)**

**Always keep air pressure below 100 psi (6,9 bar)**

*Clockwise turning of the adjusting knob increases the regulated pressure.* Erratic regulator operation or loss of regulation is due most often to dirt in the disk area of the regulator, requiring disassembly and cleaning. To clean, turn-off air supply, and depressurize. Remove bottom plug, spring and disc. Clean all parts with denatured alcohol, wipe off seat, and blow-out regulator body with compressed air. Reassemble as a unit. Before tightening plug make sure disk is centered.

## Chapter 5: Operating instructions

### 5.1 Preparation

Before operating check all air connections. If they have become disconnected, reassemble as shown in the pneumatic schematic. Adjust incoming air to the recommended pressure of 80-100 psi (5,5-6,9 bar) and check for any air leakage. If leakage is present, correct before continuing. Load clip stick, and push clips down rails and manually reset clip pusher. Check for proper feeding, and for any obstructions at the punch, knife, and die areas.

### 5.2 Operating the Machine

- \* Slide the package to be clipped into the slot of the clipper die support. When the package reaches the bottom of the throat, the trigger activates the trigger valve. The clipper goes through its cycle. The trigger valve will reset automatically at the end of the clipping cycle.
- \* The trigger valve activates the punch cylinder. The punch advances into the die forming a clip onto the product.
- \* An air signal is then sent through an adjustable flow control into a volume chamber which creates a delayed signal to extend the knife.
- \* After the cut-off knife fully extends and cuts off the excess package, start to remove the product. The trigger valve resets, retracting the cut-off knife and clip punch.
- \* Continue to remove the package out of the clipper by pulling the material away from the bottom of the die support plate.
- \* System resets, machine is ready for another cycle.



#### **Warning!**

**If a clip jams in the die area, do not attempt to cycle the machine again until the jam is cleared. Follow all safety procedures! Turn off the air supply, lock-out the emergency stop valve, before attempting to remove the clip or other obstruction from the die area.**

### 5.3 Punch assembly procedure

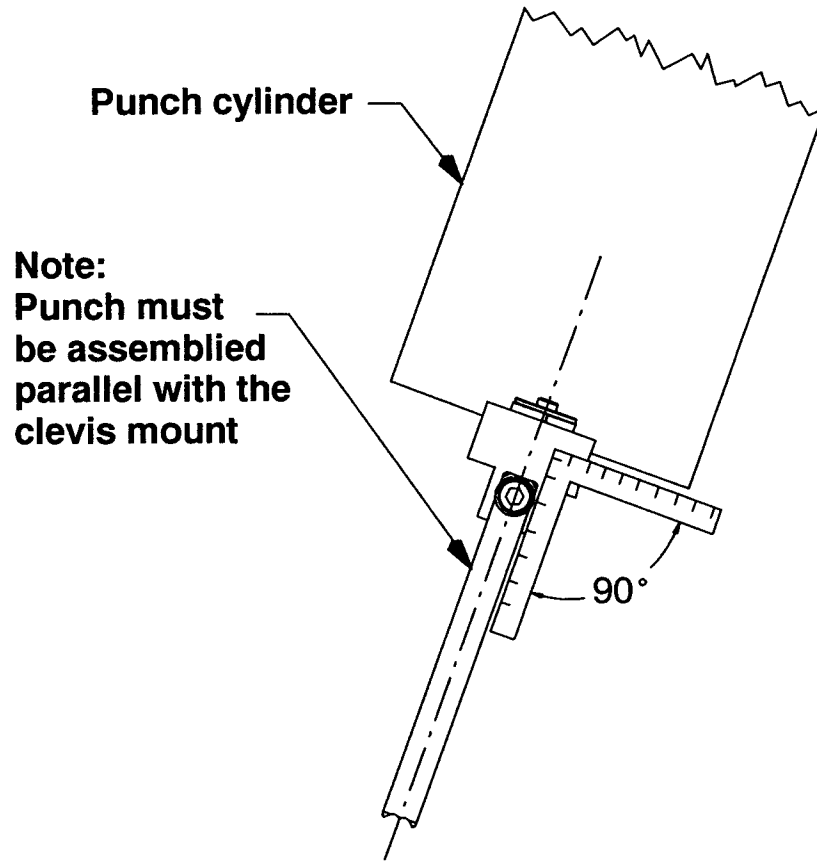

## 5.4 Mechanical crimp control

The crimp control is located in the inside of the machine, centrally mounted onto the punch cylinder support base. To adjust, loosen the lock screw in the rear of the clipper. This lock screw is against the threads of the crimp control knob to prevent it from turning. The crimp control knob is accessible through the slots in the front guard and can be rotated using the holes provided around its diameter with a Hex wrench or small Screw driver. A clockwise rotation of the adjust wheel will result in a looser clip crimp. Turning the wheel counterclockwise will result in a tighter crimp. After adjustment retighten the lock screw before returning clipper to operation.

Adjustments to the air pressure and crimp control are required to set the machine for the best closure. Differences in envelope size may require adjustment for optimum closing and operation.



**GUARD REMOVED ONLY FOR CLARITY**

**CRIMP CONTROL RING**



**Turning the wheel counterclockwise will result in a tighter crimp.**

**Hex wrench or small Screw driver used to adjust crimp control ring through access slots.**

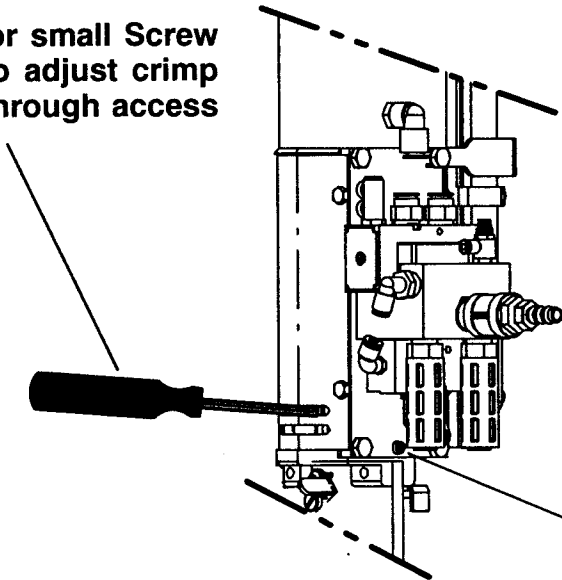

**Loosen the Lock screw before adjusting crimp control. Be sure to retighten before restarting the clipper.**

## 5.5 Clipper Cycle

- A) Push the product into slot on Die plate.
- B) Product activates the punch trigger valve.
- C) Punch assembly starts forward, and a clip is taken from rail. At the end of the stroke, the clip forms onto product in the forming die.
- D) At end of punch stroke, cut-off knife extends and trims off product tail.
- E) Valve resets system. Knife and punch retract.
- F) Remove product. Machine is ready for another cycle.

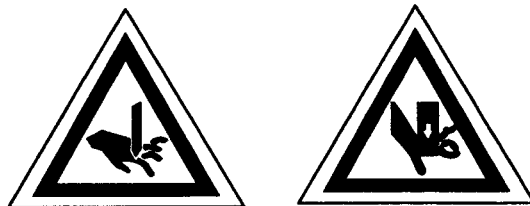
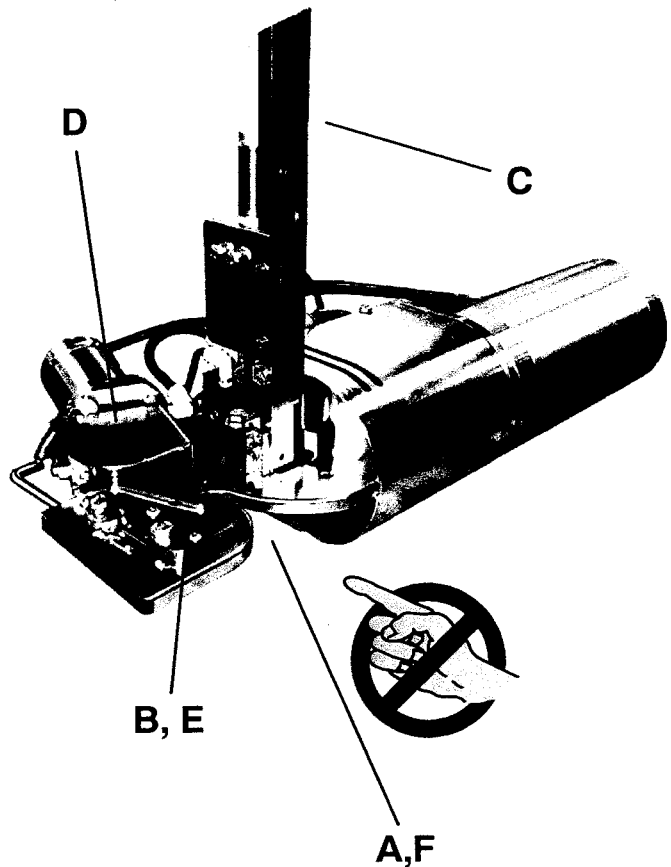

## **Chapter 6: Cleaning Procedure**

### **6.1 U.S. Department of Agriculture Guidelines**

**APPROVED CLEANING COMPOUNDS:  
U.S. DEPARTMENT OF AGRICULTURE  
FOOD SAFETY AND INSPECTION SERVICE  
(REFERENCE AGRICULTURE HANDBOOK NO. 562)**

This publication is intended to assist in applying approved cleaning methods under the USDA meat and inspection program. Cleaning materials used must be in compliance with the USDA. Compliance with the requirements set forth in the publication does not, in itself constitute authorization. Users must submit application with the USDA for consideration of suitability of preparations and their safety for use as directed.

**Submit requests for such evaluation to :**

Compounds Evaluation Unit, CPS  
Product Safety Branch  
Food Ingredient Assessment Division, Science, FSQS  
U.S. Department of Agriculture  
Building 396, Room 300, Barc-East  
Beltsville, MD 20705  
Tel (301) 344-2566

**U.S. Department of Agriculture Food Safety and Inspection Service  
Handbook No. 562 Part 5, Section 5.1 Cleaning Compound**

**(A) GENERAL USE CRITERIA**

- (1) Neutral or mildly alkaline preparations consisting of any combination of soaps, detergents, wetting agents, emulsifiers, solubilizers, and common inorganic builders may be used on any surface in and department
- (2) Strongly alkaline preparations (those containing in excess of 20 percent caustic soda or other ingredients with the equivalent causticity thereof) may be used only in soak tanks or with steam or mechanical cleaning devices in any department
- (3) Acidic preparations consisting of mineral acids, organic acids, or acidic salts may be used in any department for the removal of rust, corrosion, scale, or other deposits which are not readily removed by alkaline preparations.

**(B) RESTRICTIONS OF USE**

- (1) Before using any cleaning preparation, food products and packaging materials must be removed from the room or carefully protected. After using such preparations, all surfaces must be thoroughly rinsed with potable water.
- (2) Preparations having a characteristic odor of fragrance as diluted for use may, in the opinion of the **USDA**, interfere with sanitary inspection of food contact surfaces may not be used on food contact surfaces. They may be authorized for limited use on floors and walls only.
- (3) Preparations containing abrasive materials such as silica, pumice, etc. may be used on food contact surfaces only if care is taken to remove all odors or residues resulting from their use by thorough rinsing with potable water.
- (4) Boric acid and salts thereof, may be used in such preparations only at concentrations up to 90 percent in association with strong acids, strong alkalis, soaps, or synthetic detergents.

## **6.2 Cleaning procedure**

After use of machine, the clipper must be cleaned to remove all residues (food products) from the throat, punch, knife and die areas, (*food contact zone*). Also check all other machine surfaces and surrounding work station for material residues or contamination. All surfaces must be cleaned using the recommended materials and procedures as outlined by the U.S. Department of Agriculture Food and Inspection Service Handbook No. 562. A copy of Part 5, Section 5.1, Titled: Cleaning Compounds: is included with this manual. Cleaning product approval, in writing is required, as outlined in the copy provided.

Remember, before cleaning the clipper, ensure that the air supply has been disconnected from the clipper, and all lock-out procedures have been followed.

### **Never attempt to clean the clipper while it is attached to the air supply!**

- \* Turn off factory air and disconnect the air line from the clipper with the "Quick disconnect" attached on the rear of the clipper.
- \* Remove all guards to expose all surfaces for cleaning.
- \* Clean all surfaces as outlined by the U.S. Department of Agriculture Handbook.
- \* After cleaning, (FDA food contact approved) light mineral should be applied to all pivot areas. The internal moving parts are lubricated by the filter / regulator / lubricator.
- \* After cleaning and lubricating, reassemble all guards and check for safe function. Check for and tighten all loose connections and screws before returning machine to operation. Check for and remove all burrs around die pocket.
- \* While cleaning the clipper, inspect for worn or damaged components needing replacement. For replacement parts refer to the list of recommended spare parts, and assembly drawing.

## **Chapter 7: Maintenance**

### **7.1 General Maintenance Checklist**

- \* Check regularly for loose screws.
- \* Check the oil level in the lubricator regularly
- \* Check the air filter on a regular basis
- \* Check the knife for signs of chipping
- \* Check the end of the punch for burrs
- \* Check guards for safe function

Check for and tighten all loose connections and screws before returning machine to operation. Check for and remove any burrs around die pockets.

While cleaning the clipper, inspect for worn or damaged components needing replacement. For replacement parts refer to the list or recommended spare parts and assembly drawings.

## **7.2 Lubricator Maintenance**

The oil level in the lubricator must never be allowed to drop below the end of the dip tube. To replenish oil, first shut off the air supply, lock-out the system. Remove the slotted filler plug and fill to oil level mark. Replace and tighten plug.

Normally, the lubricator should require only occasional cleaning, provided clean oil is used, and the air supply is kept clean by the filter system. However, if no oil drips through the sight glass, and the oil supply has been replenished, the lubricator requires cleaning.

*Check the following before cleaning the lubricator:*

- \* Make sure there is sufficient oil in the bowl.
- \* Check to determine whether there is air pressure ahead of the lubricator
- \* Check the air flow from the lubricator

If each of these areas are functioning properly, continue to clean the lubricator.

## **7.3 Filter / Regulator / Maintenance**

The air filter is equipped with an automatic drain that should be cleaned periodically to maintain maximum filter efficiency. Open drain cock under the filter periodically and drain off any bowl accumulation before it reaches level of the lower baffle. A visible coating of dirt on the filter element surface or an excessive pressure drop in an indication that cleaning is necessary.

To clean the filter, turn off air supply, lock out system, and depressurize. Loosen locking collar and remove bowl. Clean all parts with denatured alcohol and blow out the inside with compressed air.

To clean the regulator, turn off air supply, lock out system, and depressurize. Remove the bottom plug, spring, and disk. Clean all parts with denatured alcohol. Wipe off seat and blow out regulator body with compressed air. Reassemble the filter / regulator unit. Before tightening the plug, make certain the disk is centered.

After cleaning and servicing, the air regulator may need adjusting. Adjust the incoming air to the recommended pressure settings of 80-100 psi, (5,5-6,9 bar). Always keep air pressure below 100 psi, (6,9 bar).

Always check the air muffler for oil build up and blockage. A muffler caked with oil or accumulated contamination will restrict the porting of the used air into the atmosphere, and slow down the machine. Always check the mufflers when servicing the filter / regulator unit, and replace as required.

## Chapter 8: Trouble Shooting Guide

### **Symptoms**

### **Solution**

***Clipper has no power***

- Air connection may be loose. Check all air connections.
- or Regulator may be turned off. Check the regulator unit.
- or Water may be in the system. Drain and change the filter.

***Clipper is slow***

- Water may be in the system. Drain the water and change the filter.
- or Muffler may be clogged. Replace the muffler.
- or Pressure to the clipper is low. Check the pressure setting and increase if necessary.
- or Air lines are pinched. Replace the air lines.
- or Cylinder is stuck. First check for pinched air line and check the air pressure. If cylinder is still stuck, disconnect air line and check for broken or worn parts. Replace bad parts or air cylinder.

***Punch does not retract***

Knife blade housing may be jammed with product residue. Disassemble and clean.

***Knife does not cut***

Check knife for nicks and sharpen as needed.

***Malformed clips***

- Punch or die may be damaged. Replace as necessary.
- or Air pressure may be too low or too high. Check air pressure and adjust if necessary.

***Clips are loose and seal poorly***

- Check crimp control and adjust if needed.
- or Air pressure is too low. Check air pressure and adjust if necessary.
- or Punch and die may be worn down. Check for wear on punch and die, and replace if needed.

## Chapter 9: Spare parts List

When ordering replacement or spare parts, always include the following:

**Machine model number and date of purchase:**

**Identifying part numbers stamped on part:**

**Part number or numbers on spare parts list,  
or identifying item numbers on assembly drawings:**

### 9.1 Recommended Spare parts

Item	Part No.	Description	Qty.
1	05-0126	Die, Z400	1
2	11-0141	Knife, for LH clipper	1
3	13-0115	Punch, Z4111	1
4	17-0131	Torsion spring, pawl	2
5	21-0164	SMC Valve VFA5120-03	1
6	21-0223	Valve VFA3130-02	1
7	21-1810	Air Valve #3P	1
8	29-0858	M3 x 30mm lg. Soc. hd. Set screw	2
9	62-0045	2-014 O-ring 1/16 x .629	1
10	62-2731	2-017 O-ring 1/16 x .816	1
11	99-1242	M3 Lockwasher	2

**The above items may be ordered by individual part numbers  
or they may be ordered as a kit: No. 55-0099**

### 9.2 Loose Parts List

Item	Part No.	Description	Qty.
1	28-4636	3/8 Air hose Assembly	1
2	80-1302	SZ4135L Operators Manual	1

## Chapter 10: Assembly Drawings

SZ4135L	Clipper Model SZ4135L
00-1597	Clip Pusher Cylinder Assembly RH
00-1716	Rail Assembly - 4100H
00-1990	Punch cylinder Assembly
00-1991	Lower Assembly SZ4135L
00-2123	Horizontal Clipper Mount
21-0432	Manifold Assembly
24-0066	Watts Qube FRL
28-4636	3/8" Hose Assembly
63-0301	Pneumatic Schematic

USED ON

Z2105

Z2115

Z4135

Z4136

28-9063 1 REQ'D.  
3/8 MALE BARB PM-13 BN

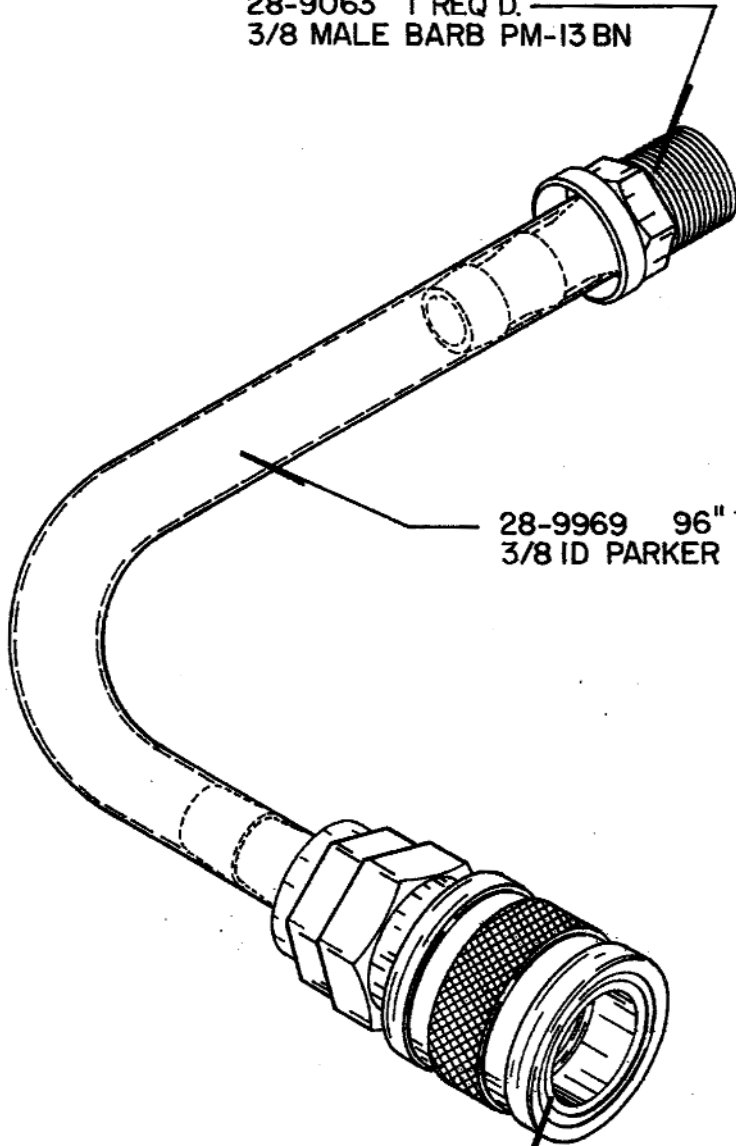

28-9969 96" ± 2" REQ'D.  
3/8 ID PARKER 801 HOSE

28-9066 1 REQ'D.  
3/8 BARB SOCKET 1714 BN

M82

REV. 1

3/8 SUPPLY HOSE x 8 FT.

28-4636

5-26-77

**REVISIONS**

NO.	DESCRIPTION	DATE	APPROVED	NO.	DESCRIPTION	DATE	APPROVED
01	SEE ECN 24-0066-01	4/00	SDG				
02	SEE ECN 24-0066-02	10/01	SDG				
03	SEE ECN 24-0066-03	12/01	SDG				

A SUBSTITUTE ITEM SHALL NOT BE USED WITHOUT PRIOR TESTING AND APPROVAL BY ENGINEERING

**THIS SUB-ASSEMBLY IS MADE FROM:**  
 1 - 24-0075 WATTS QUBE 75 FILTER/REGULATOR  
 2 - 24-0076 WATTS QUBE 75 LUBRICATORS

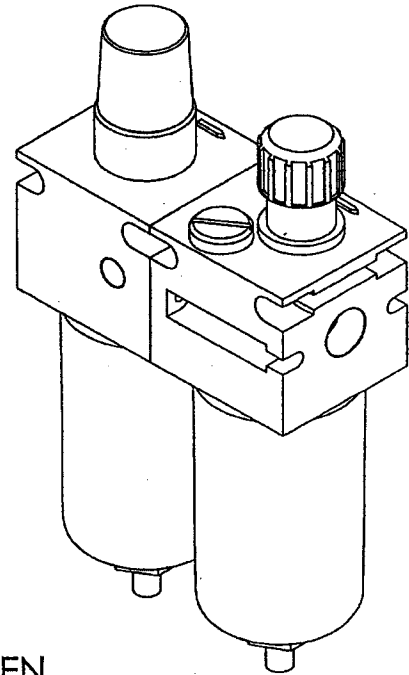

**WATTS**

- QUBE 75 SERIES INTERGRAL FILTER/REGULATOR
- 3/8" PORTS
- ZINC BOWL WITH WRAP AROUND SIGHT GLASS
- 40 MICRON FILTER\*
- PRESSURE RANGE 0 - 125 PSIG
- MANUAL DRAIN
- QUBE 75 SERIES LUBRICATOR
- 3/8" PORTS
- ZINC BOWL WITH WRAP AROUND SIGHT GLASS
- MANUAL DRAIN
- UNITS ARE SEALED WITH A 2-020 O-RING BETWEEN THEM AND HELD TOGETHER WITH (2) 10-32 X 1/2 BUTTONHEAD SCREWS

\*REPLACEMENT FILTER # : 24-0067

WATTS FULD AIR	C75-03BLWJCWX72
----------------	-----------------

NAME OF VENDOR	VENDOR ADDRESS	VENDOR PART NO.
----------------	----------------	-----------------

	CHECKED BY _____ DATE D. MAY 10-31-2001	SOURCE CONTROL DRAWING WATTS QUBE 75 SERIES FRL 3/8"
	APPROVED BY _____ DATE D. MAY 10-31-2001	
DRAWN BY _____ DATE S. GRIGGS 10-31-2001	RELEASED BY _____ DATE S. GRIGGS 10-31-2001	SIZE <b>A</b>
SCALE NTS		DO NOT SCALE DRAWING SHEET 1 of 1

This drawing (or print) is the property of Tipper Tie, Apex NC and shall not be traced, photographed, photocopied or reproduced in any manner nor used for any purpose whatsoever except by written permission of Tipper Tie.

ITEM NO.	QTY.	PART NO.	DESCRIPTION
1	1	100-1716	RAIL ASSEMBLY - 4100H
2	1	100-1990	PUNCH CYLINDER ASSEMBLY
3	1	21-0432	MANIFOLD ASSEMBLY
4	1	100-1991	LOWER ASSEMBLY-SZ4135
5	1	116-0613	3/4 HEX SPACER
6	1	132-1904	CLIPPER BACK PLATE
7	1	10-5167	BALL MOUNTING COVER PLATE
8	1	10-2965	PUNCH CYLINDER MOUNT
9	1	109-0598	CENTER GUARD - 5" BORE
10	1	129-1022	M8 X 40 MM LG CUP PT SET SCREW
11	2	129-0585	M8 X 25 MM LG FH SST
12	2	129-0688	M8 X 20 MM LG HH SST DIN 933
13	1	129-0584	M8 X 20 MM LG FH SST
14	4	129-0950	M12 X 30 MM LG SH SST
15	4	129-0667	M6 X 10 MM LG HH SST DIN 933
16	2	129-0922	M8 X 20 MM LG SH SST
17	2	129-0546	M5 X 16 MM LG FH SST
18	1	199-0604	PART NUMBER TAG
19	2	129-4683	#2 X 3/16 LG RND HEAD U-TYPE SCR
20	1	128-0199	MALE ELBOW KQ06-01S (M)
21	1	128-0328	1/8 BSPT PIPE PLUG
22	2	128-0186	MALE ELBOW KQ112-03S (M)
23	2	128-0185	MALE ELBOW KQ08-02S (M)
24	2	128-0300	UNION TEE KQ106-00 (M)

**LOOSE PARTS**

24-0046 - WATTS FRL  
 28-4436 - 3/8" SUPPLY HOSE  
 80-1302 - MANUAL

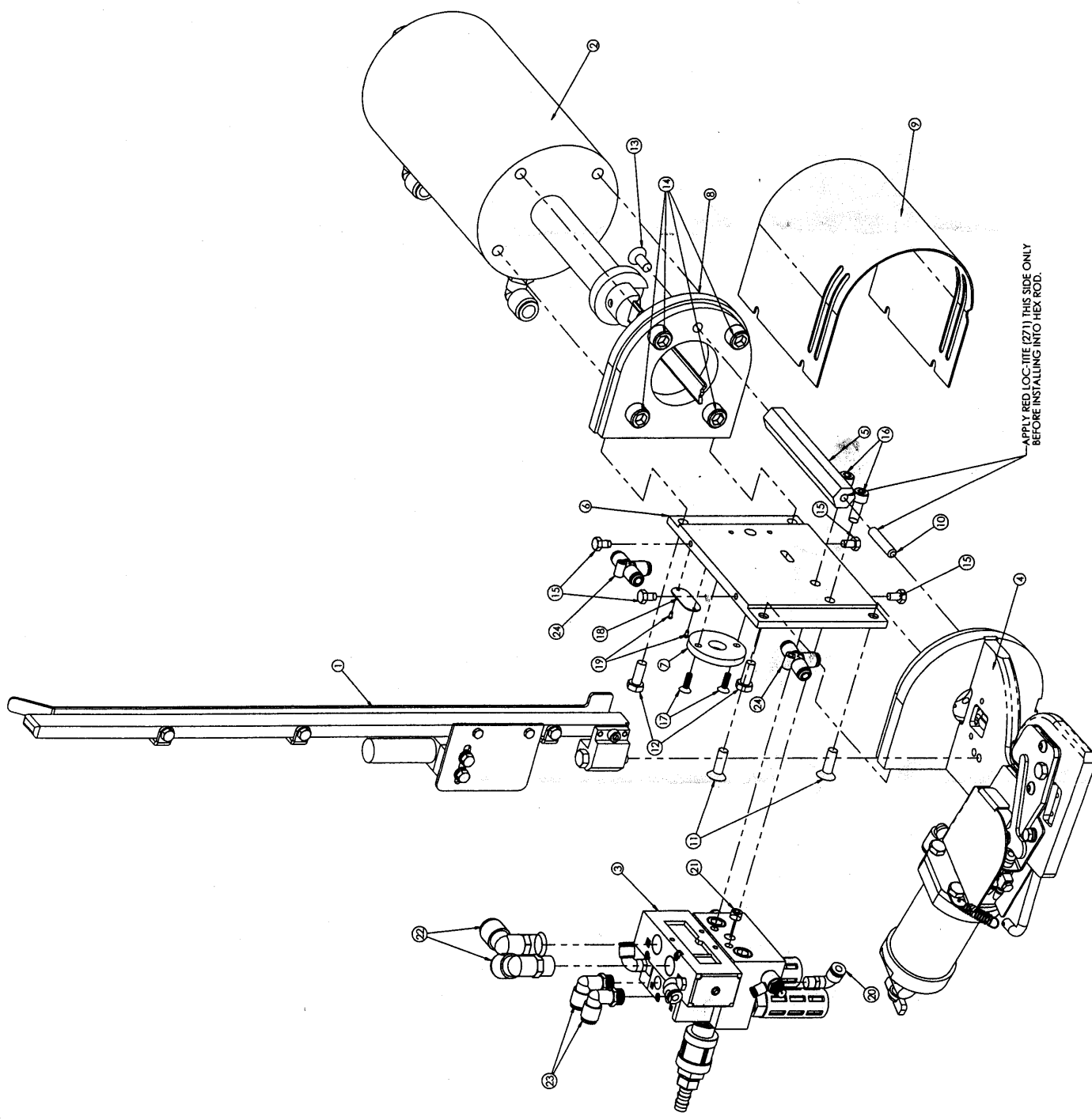

APPLY RED LOC-TITE (271) THIS SIDE ONLY BEFORE INSTALLING INTO HEX ROD.

REV	DATE	DESCRIPTION	BY	CHKD
1	11/28/88	REVISED TO INCLUDE 07/23/02	W	W
2	07/23/02	REVISED TO INCLUDE 07/23/02	W	W
3	07/23/02	REVISED TO INCLUDE 07/23/02	W	W
4	07/23/02	REVISED TO INCLUDE 07/23/02	W	W
5	07/23/02	REVISED TO INCLUDE 07/23/02	W	W
6	07/23/02	REVISED TO INCLUDE 07/23/02	W	W
7	07/23/02	REVISED TO INCLUDE 07/23/02	W	W
8	07/23/02	REVISED TO INCLUDE 07/23/02	W	W
9	07/23/02	REVISED TO INCLUDE 07/23/02	W	W
10	07/23/02	REVISED TO INCLUDE 07/23/02	W	W
11	07/23/02	REVISED TO INCLUDE 07/23/02	W	W
12	07/23/02	REVISED TO INCLUDE 07/23/02	W	W
13	07/23/02	REVISED TO INCLUDE 07/23/02	W	W
14	07/23/02	REVISED TO INCLUDE 07/23/02	W	W
15	07/23/02	REVISED TO INCLUDE 07/23/02	W	W
16	07/23/02	REVISED TO INCLUDE 07/23/02	W	W
17	07/23/02	REVISED TO INCLUDE 07/23/02	W	W
18	07/23/02	REVISED TO INCLUDE 07/23/02	W	W
19	07/23/02	REVISED TO INCLUDE 07/23/02	W	W
20	07/23/02	REVISED TO INCLUDE 07/23/02	W	W
21	07/23/02	REVISED TO INCLUDE 07/23/02	W	W
22	07/23/02	REVISED TO INCLUDE 07/23/02	W	W
23	07/23/02	REVISED TO INCLUDE 07/23/02	W	W
24	07/23/02	REVISED TO INCLUDE 07/23/02	W	W

CLIPPER MODEL SZ4135L  
 SZ4135L-02

This drawing (or print) is the property of Tipper Tie. Apex NC and shall not be traced, photographed, photocopied, or reproduced in any manner nor used for any purpose whatsoever except by written permission of Tipper Tie.







ITEM NO.	QTY.	PART NO.	DESCRIPTION
1	1	04-0365	AURORA CYL 5"BORE X 4 5/8"STROKE
2	1	18-0256	Z4151 PUNCH SUPPORT
3	1	13-0115	PUNCH - Z4111
4	2	28-0184	MALE ELBOW KQL12-04S (M)
5	1	29-0410	M8 X 16 MM LG SH SST NYLOCK
6	1	99-1246	8MM ID LOCKWASHER SST
7	4	29-0826	M12 X 20 MM LG HH SST DIN 931

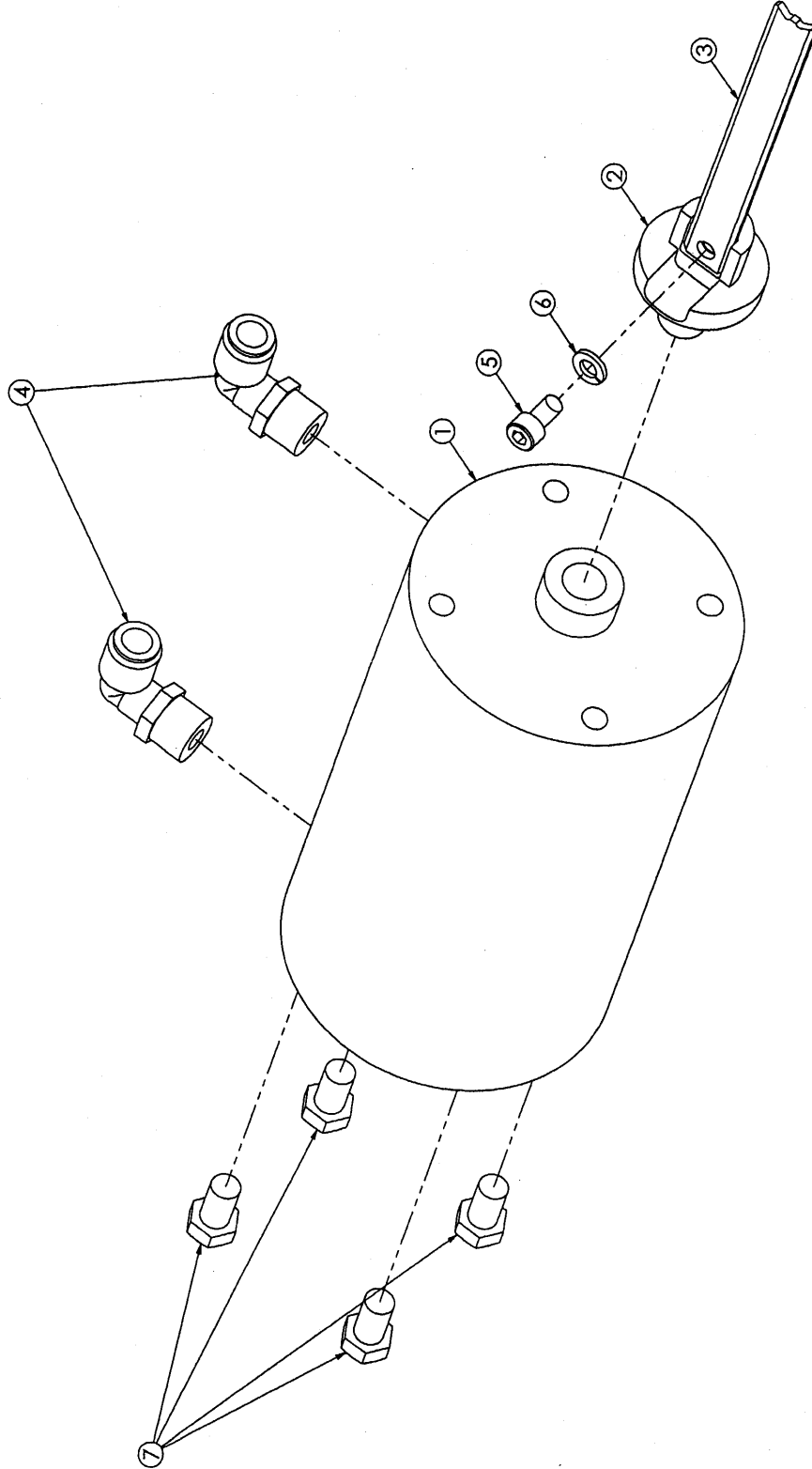

NO.	DATE	DESCRIPTION	APPROVED	NO.	DATE	DESCRIPTION	APPROVED

**SW**  
**TIPPER TIE**  
DESIGNED BY DATE  
APPROVED BY DATE  
RELEASED BY DATE  
 A. HOLLOWAY 07/19/02  
 D. MAY 07/19/02  
 A. HOLLOWAY 07/19/02

SZ4135 PUNCH CYL. ASSEMBLY  
 SIZE **D**  
 SCALE 1:1  
 PART NO. **00-1990-00**  
 OF **1** SHEETS

This drawing (or print) is the property of Tipper Tie, Apex NC and shall not be traced, photographed, photocopied or reproduced in any manner not used for any purpose whatsoever except by written permission of Tipper Tie.







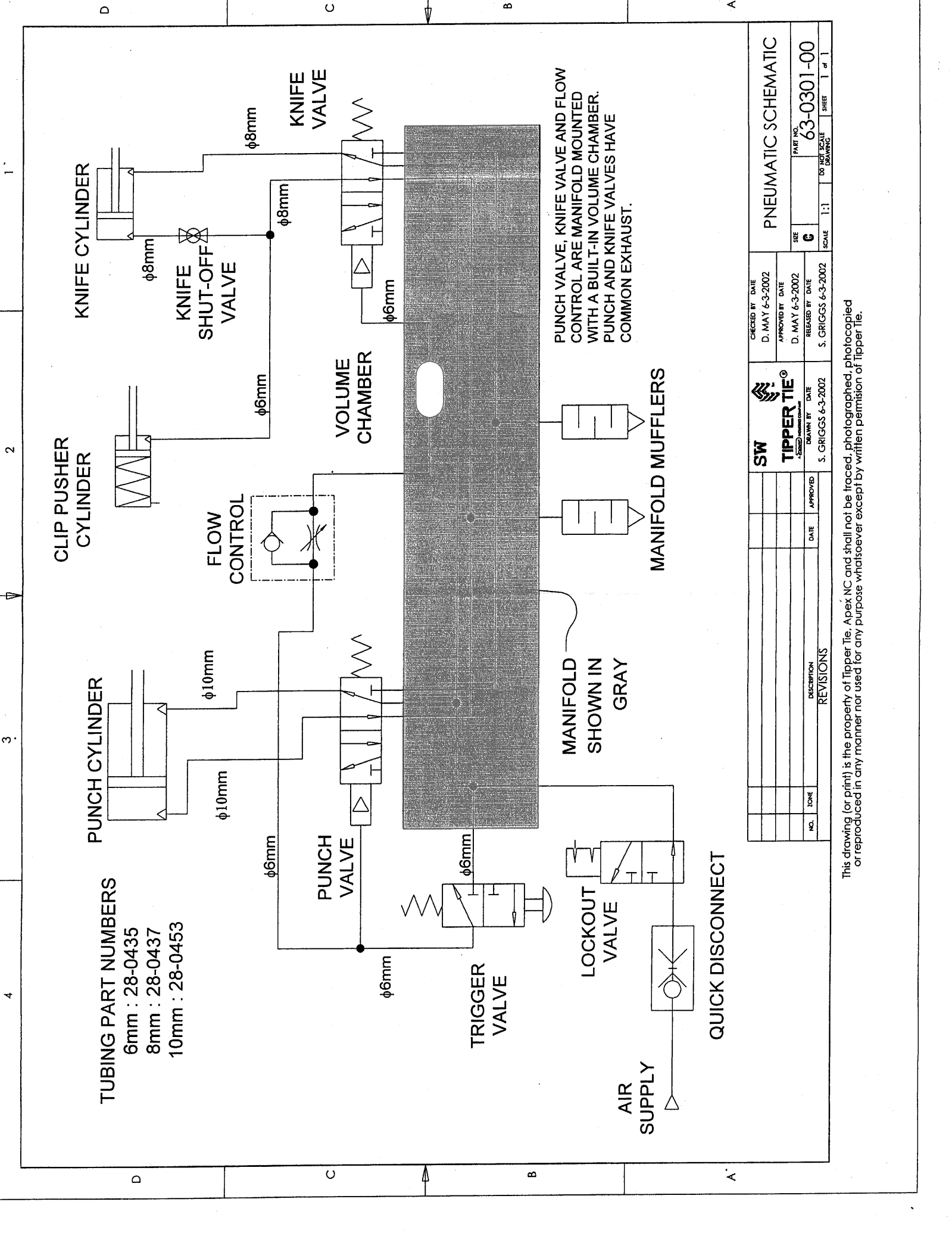

**TUBING PART NUMBERS**  
 6mm : 28-0435  
 8mm : 28-0437  
 10mm : 28-0453

PUNCH VALVE, KNIFE VALVE AND FLOW CONTROL ARE MANIFOLD MOUNTED WITH A BUILT-IN VOLUME CHAMBER. PUNCH AND KNIFE VALVES HAVE COMMON EXHAUST.

MANIFOLD SHOWN IN GRAY

MANIFOLD MUFFLERS

QUICK DISCONNECT

CHECKED BY DATE D. MAY 6-3-2002		DRAWN BY DATE S. GRIGGS 6-3-2002		PNEUMATIC SCHEMATIC	
APPROVED BY DATE D. MAY 6-3-2002		RELEASER BY DATE S. GRIGGS 6-3-2002		PART NO. 63-0301-00	
NO.		DESCRIPTION		SCALE 1:1	
DATE		APPROVED		SHEET 1 of 1	
REVISONS		REVISONS		DRAWING	

This drawing (or print) is the property of Tipper Tie, Apex NC and shall not be traced, photographed, photocopied or reproduced in any manner nor used for any purpose whatsoever except by written permission of Tipper Tie.



**Cleveland Range, LLC.**  
1333 East 179<sup>th</sup> Street  
Cleveland, OH 44110  
Phone: (216) 481-4900  
Fax: (216) 481-3782  
<http://www.clevelandrange.com>

## CLIPPER VAC & CLIPPER

### Steam Requirements

- Line sizes
- Phase
- Amp. draw

### Air Requirements

- Line size
- Pressures
- Check lubricator
- Check for leaks

### Clipper Mounting

Model no. \_\_\_\_\_  
Serial no. \_\_\_\_\_

Comments: