

RETRACTABLE SPLASH GUARD / PAN SHELF*, FOR ST STAND DRAIN DRAWERS

Project _____
 Item _____
 Quantity _____
 FCSI Section 11400 _____
 Approved _____
 Date _____

Models

- SG-28 • SG-42
- (For stand model ST-55 order two SG-28's.)

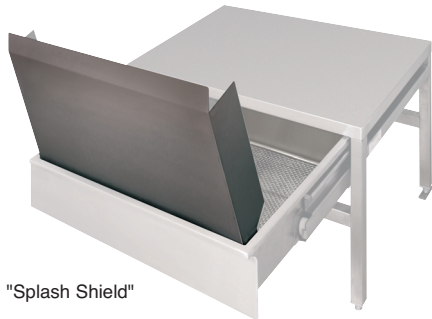

"Splash Shield"



"Pan Shelf"

Standard Features

- Designed for higher volume pouring
- Dual function:
 - Splash Guard - for safer and cleaner pouring
 - Pan Shelf - when pans are placed on it they are closer to the pouring lip of kettle or skillet for easier and cleaner pouring
- Heavy gauge stainless steel construction for rugged durability
- Easily removable for cleaning

* Only available for ST-28 stands built on or after September 1, 2004.

For ST stands built prior to September 1, 2004, a complete drawer assembly with retractable splash guard/pan shelf is available (DDSG-28, DDSG-42). For stand model ST-55 order two DDSG-28's.

Short Form Specifications

Shall be CLEVELAND, Retractable Splash Guard/Pan Shelf, all stainless steel assembly.

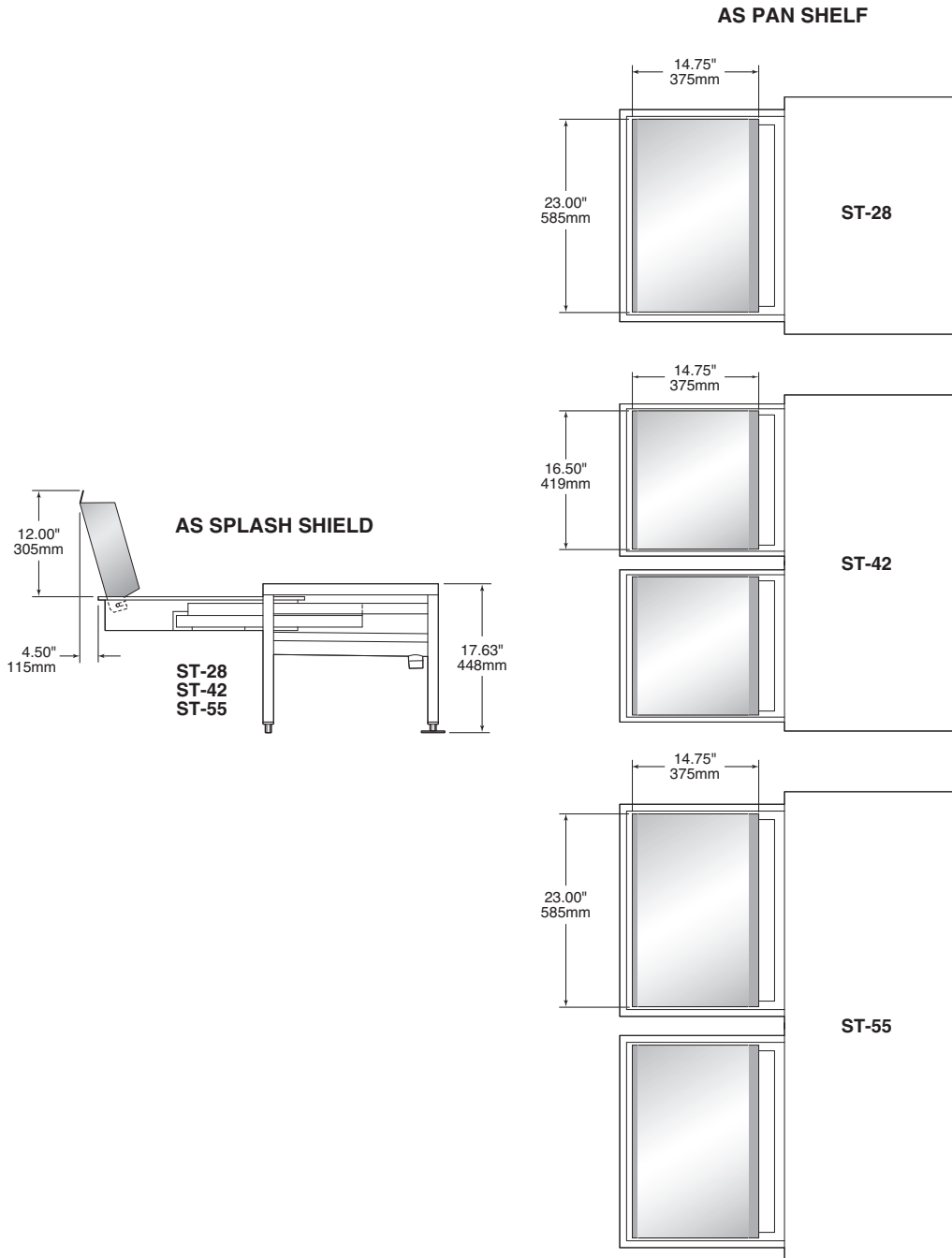

NOTES:

Cleveland Range reserves right of design improvement or modification, as warranted.
 Many regional, state and local codes exist and it is the responsibility of the owner and installer to comply with the codes.
 Installations of Back Flow Preventers, Vacuum Breakers and other specific code requirements are the responsibility of the Owner and Installer.
 Cleveland Range equipment is built to comply with applicable standards for manufacturers. Included among those approval agencies are U.L., NSF, CGA, CSA, ETL and others.

(NOT TO SCALE)