

# SLIDING DRAIN PAN FOR OPEN BASE R-SERIES SKILLETTS

Project \_\_\_\_\_  
 Item \_\_\_\_\_  
 Quantity \_\_\_\_\_  
 FCSI Section 11400 \_\_\_\_\_  
 Approved \_\_\_\_\_  
 Date \_\_\_\_\_

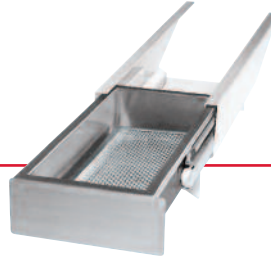

## Models

- SLD-TD • SLD

MODEL SLD-TD (Shown on model SGL-40-TR)

Complete with:

- Sliding Drain Drawer
- 2" Tangent Draw-Off Valve



## Standard Features

- Drain Drawer and 2" Tangent Draw-Off Valve mounted on left-hand side of unit.
- Modified Pan Hinge allows full tilting.
- Durable 12 gauge, 304 Stainless Steel construction.
- 1 1/4" NPT Drain Pipe Connection.
- Removable Stainless Steel Grate.
- Durable Nylon Rollers.

MODEL SLD-TD (Shown on model SGL-40-TR)

Complete with:

- Sliding Drain Drawer



## Standard Features

- Drain Drawer and Pour Spout mounted on left-hand side of unit.
- Cover Handle mounted on right-hand side of unit.
- Durable 12 gauge, 304 Stainless Steel construction.
- 1 1/4" NPT Drain Pipe Connection.
- Removable Stainless Steel Grate.
- Durable Nylon Rollers.

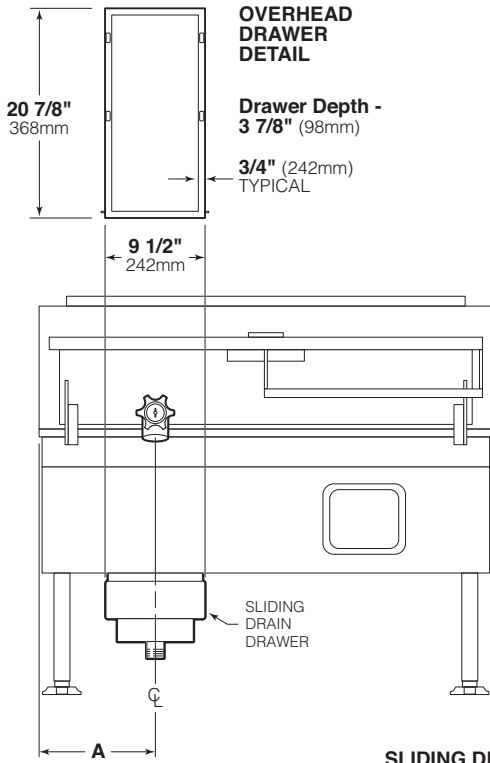
**DIMENSIONS**

CAPACITY	A
30 GAL.	9 3/16"
	(234mm)
40 GAL.	12 3/32"
	(307mm)

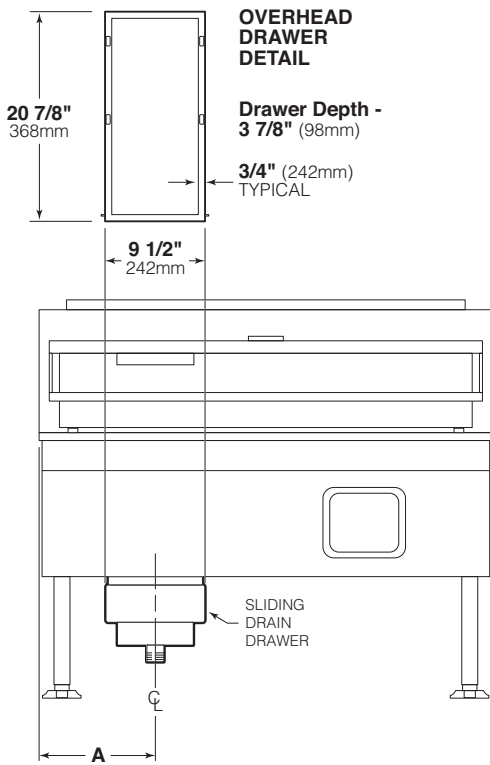
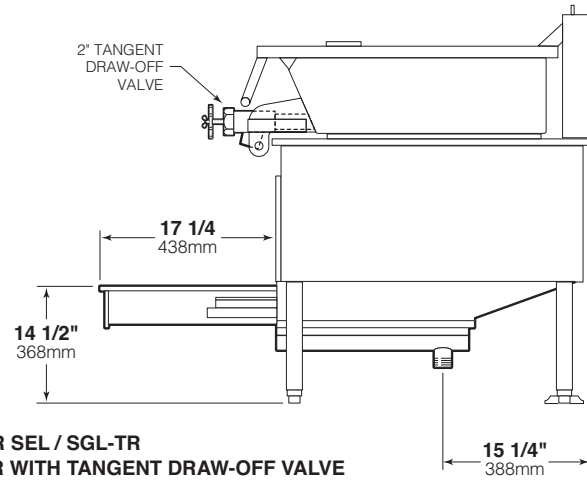

FOR SEL / SGL-TR  
SLIDING DRAIN DRAWER

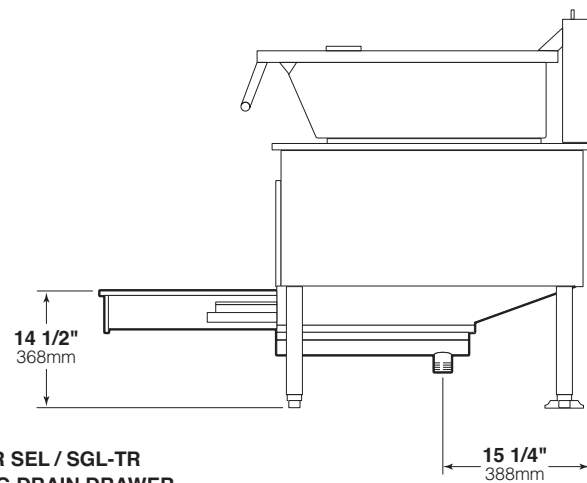
**NOTES:**

Cleveland Range reserves right of design improvement or modification, as warranted.  
 Many regional, state and local codes exist and it is the responsibility of the owner and installer to comply with the codes.  
 Cleveland Range equipment is built to comply with applicable standards for manufacturers. Included among those approval agencies are U.L., NSF, CGA, CSA, ETL and others.

(NOT TO SCALE)