

Cleveland

Service Manual

FREE STANDING GAS SKILLETTS

MODEL: SGM-X
SGL-X



SGL-T4

SKI-06

OPERATING CONTROLS AND INDICATORS

For your better understanding and confidence, the following explanation of the control system used on these skillets is offered.

Item No.	Description	Function
13	Gas Control Valve (Skillet Bottom Dwg.)	Controls main gas supply to the skillet.
2	Pilot Light (Electrical Components Dwg.)	When illuminated, the lower pilot light indicates electrical power is on to the skillet and the upper pilot light indicates the main gas burners are on.
4	Thermostat Control Knob (Electrical Components Dwg.)	This control knob allows the operator to select various heat increments for operating the skillet.
7	On/Off Toggle Switch (Electrical Components Dwg.)	Controls electrical power to the skillet.
9	Timer Control Knob (Electrical Components Dwg.)	This knob controls the bell timer and allows the operator to select a time interval after which a bell will sound.
15	Tilt Switch (Electrical Components Dwg.)	When activated this switch will raise or lower the skillet pan.
13, 17	Hand Wheel (Hydraulic Lift Mechanism Dwg.)	Turn counter-clockwise to raise skillet pan.
12, 16	Push Button (Hydraulic Lift Mechanism Dwg.)	Press to allow skillet pan to lower.
10	Micro Switch (Electric Jack Assembly Dwg.)	Protective switch to prevent burners from igniting while skillet pan is in a raised position.
27	Micro Switch (Hydraulic Jack Assembly Dwg.)	Protective switch to prevent burners from igniting while skillet pan is in a raised position.

PARTS LIST - SKILLET BOTTOM

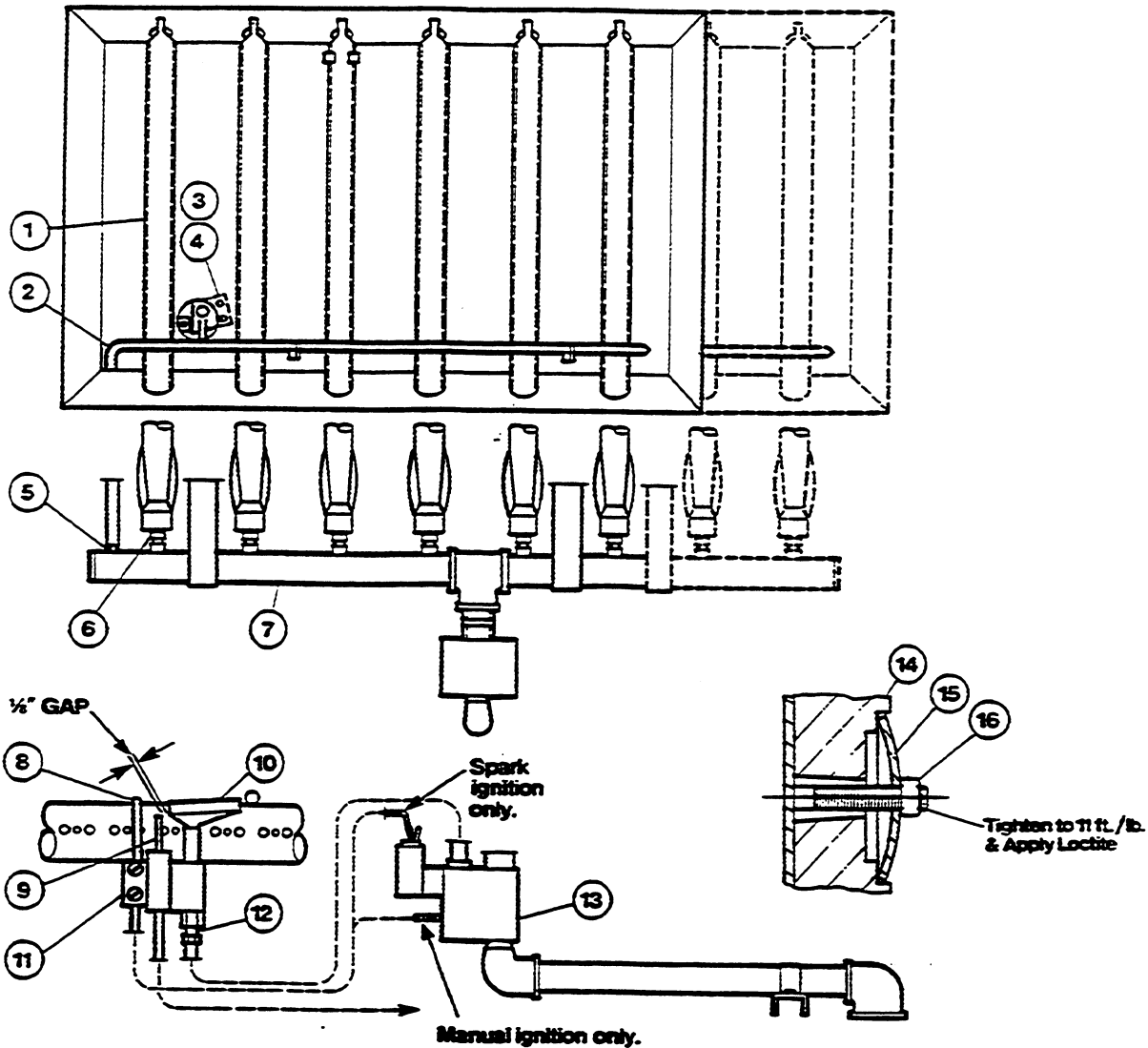

Item No.	Part No.	Description	Qty.
1	SK50502	Burner	6, 8
2	SK50520	Zip Tube (SGL, SGM-30-X)	1
	SK50521	Zip Tube (SGL, SGM-40-X)	1
3	SK50553	Bracket, Pilot Mounting	1
4	FA10360	Screw, 10-32 x 1/4"	2
5	SK50363	Orifice, Zip Tube, Natural Gas (0-2000 Ft. Elev. #61 Drill)	1
	SK50669	Orifice, Zip Tube, Natural Gas (2000-4000 Ft. Elev. #62 Drill)	1
	SK50671	Orifice, Zip Tube, Natural Gas (4000-6000 Ft. Elev. #63 Drill)	1
	SK50364	Orifice, Zip Tube, L.P. (0-2000 Ft. Elev. #72 Drill)	1
	SK50670	Orifice, Zip Tube, L.P. (2000-4000 Ft. Elev. #73 Drill)	1
	SK50672	Orifice, Zip Tube, L.P. (4000-6000 Ft. Elev. #74 Drill)	1

6	SK50503	Orifice, Burner, Natural Gas (0-2000 Ft. Elev. #52 Drill)	6, 8
	SK50505	Orifice, Burner, Natural Gas (2000-4000 Ft. Elev. #1/16 Drill)	6, 8
	SK50507	Orifice, Burner, Natural Gas (4000-6000 Ft. Elev. #53 Drill)	6, 8
	SK50504	Orifice, Burner, L.P. (0-2000 Ft. Elev. #57 Drill)	6, 8
	SK50506	Orifice, Burner, L.P. (2000-4000 Ft. Elev. #58 Drill)	6, 8
	SK50508	Orifice, Burner, L.P. (4000-6000 Ft. Elev. #59 Drill)	6, 8
7	SK00192	Manifold, Burner (SGL, SGM-30-X)	1
	SK00193	Manifold, Burner (SGL, SGM-40-X)	1
8	KE51111	Pilot Flame Sensor (Thermopile Type) (Manual Ignition)	1
	KE51159	Pilot Flame Sensor (Mercury Vapour Type) (Spark Ignition)	1
9	KE01016	Ignition Electrode (Spark Ignition)	1
10	KE51114	Pilot Burner	1
11	KE51115	Holder, Pilot Flame Sensor (Manual Ignition)	1
12	KE51116	Orifice, Pilot, Natural Gas (.020")	1
	KE51162	Orifice, Pilot, L.P. (.0145")	1
13	KE51155	Combination Gas Control Valve, Natural Gas, 24 VAC (Spark Ignition)	1
	KE51163	Combination Gas Control Valve, L.P., 24 VAC (Spark Ignition)	1
	SK50608	Combination Gas Control Valve, Natural Gas, 24 VAC (Manual Ignition)	1
	SE00043	Combination Gas Control Valve, L.P., 24 VAC (Manual Ignition)	1
	KE51110	Combination Gas Control Valve, Natural Gas, 120 VAC (Manual Ignition)	1
	KE51161	Combination Gas Control Valve, L.P., 120 VAC (Manual Ignition)	1
14	SK50249	Heat Spreader (R.H. End Piece)	1
	SK50531	Heat Spreader (L.H. End Piece)	1
	SK50532	Heat Spreader (with Thermostat cut-out)	1
	SK50213	Heat Spreader (Plain)	3,5
15	SK50416	Washer, Spherical	28,36
16	FA21024	Nut, 5/16 - 18	28,36

Use only replacement parts which are factory supplied as to preserve the certification of Underwriters Laboratories, American Gas Association, Canadian Standards Association or Canadian Gas Association (as applicable). The use of other than factory supplied replacement parts will void the warranty.

ELECTRICAL COMPONENTS

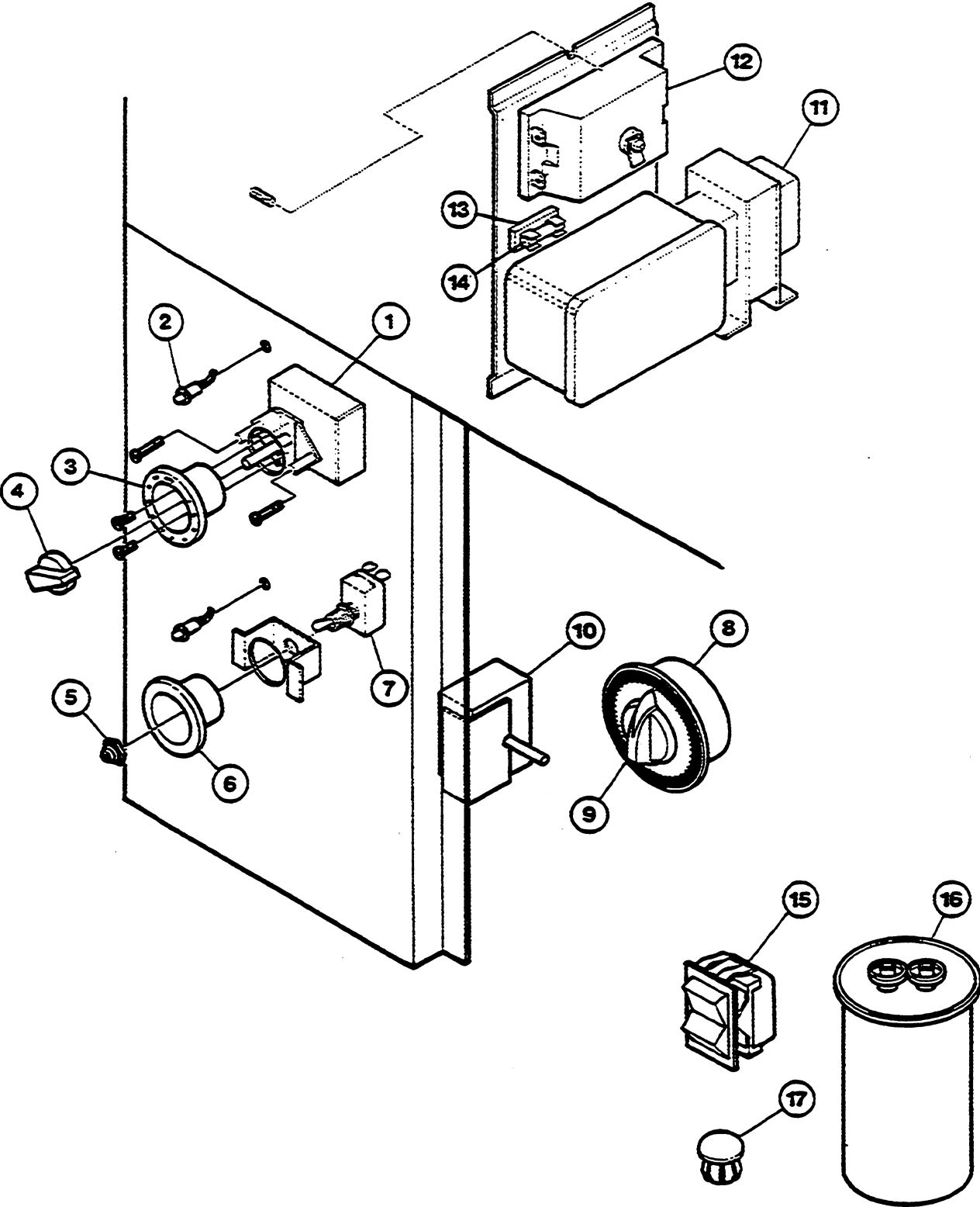

PARTS LIST - ELECTRICAL COMPONENTS

Item No.	Part No.	Description	Qty.
1	SK50606	Thermostat, Operating (230°C)	1
2	SK50539	Pilot Light	2
3	SK00031	Bezel, Thermostat (°F)	1
	SK00180	Bezel, Thermostat (°C)	1
4	SK50059	Knob, Thermostat	1
5	SK50062	Rubber Boot	1
6	SK50540	Bezel, ON/OFF Switch	1
7	KE50504	Switch, Toggle, ON/OFF, SPST	1
8-9	SK50725	Timer	1
9	11301	Knob, Timer	1
10	SK50607	Thermostat, Safety (280°C)	1
11	KE51164	Transformer, 120/24 V	1
12	KE51167	Pilot Re-Lite (Nat. Gas)	1
	KE51405	Pilot Re-Lite and Cycling Pilot Safety Timer Combination (L.P. Gas)	1
13	KE51139	Fuse Holder	1
14	KE51169	Fuse, 1 1/2 Amp (Spark Ignition)	1
	KE51140	Fuse, 4/10 Amp (Manual Ignition)	1
15	SK50680	Switch, Rocker, Momentary	1
16	SK50728	Capacitor, 20 MFD (Silver, Metal)	1
16a	ke5138	Capacitor, 30 MFD (Silver Metal)	1
		(Please order Item No. 16)	
16b	6	Capacitor, 27-32 MFD (Black, Plastic) (Please order Item No. 16 and See Note)	1
17	SK50397	Plug Button	1

Note: When replacing this capacitor, the original mounting clip must be broken off, two holes drilled in the mounting box and a tie wrap used to hold the new capacitor.

Use only replacement parts which are factory supplied as to preserve the certification of Underwriters Laboratories, American Gas Association, Canadian Standards Association or Canadian Gas Association (as applicable). The use of other than factory supplied replacement parts will void the warranty.

**PARTS LIST - HYDRAULIC LIFT MECHANISM
(PRIOR TO APRIL 1, 1988)**

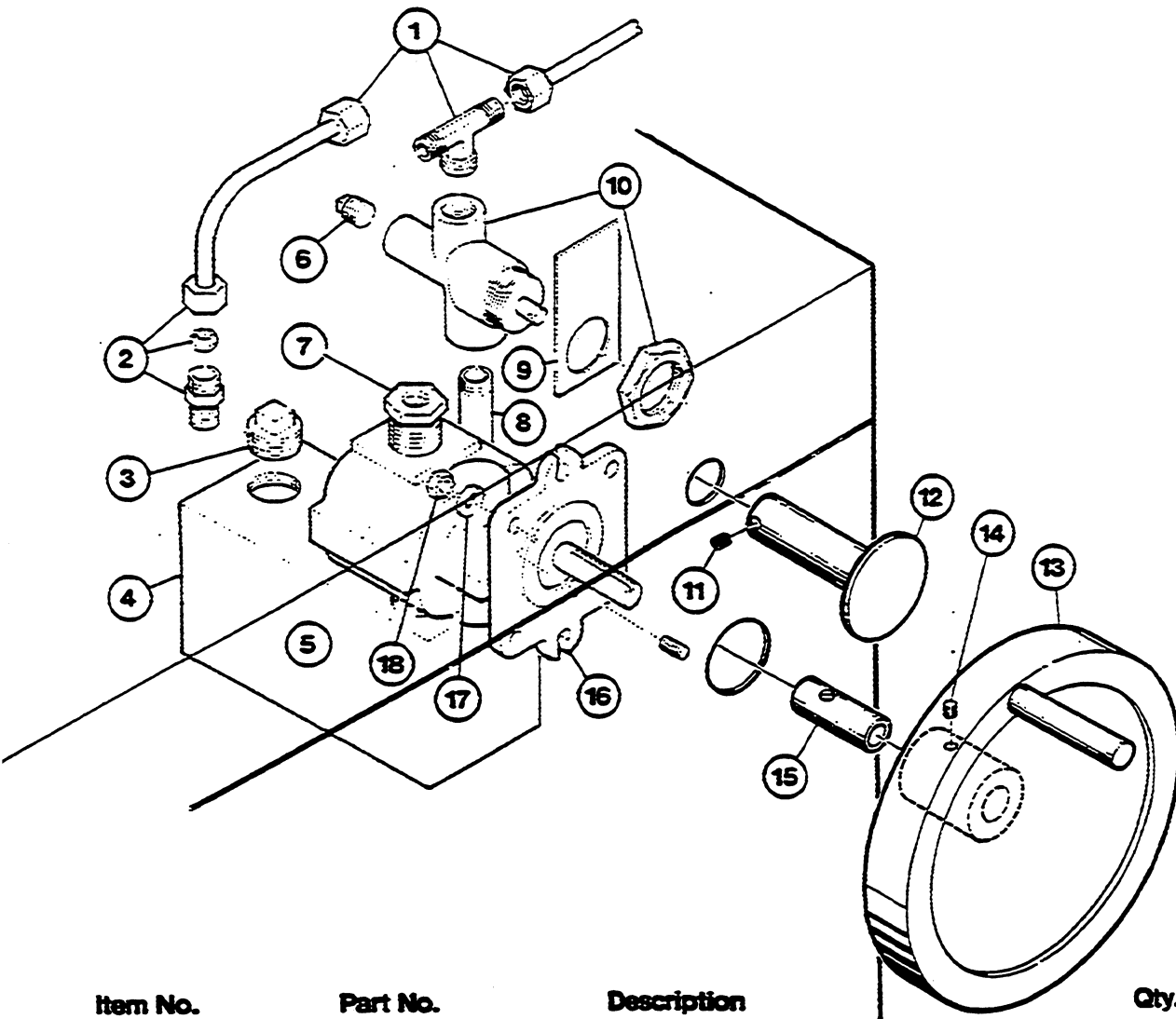

Item No.	Part No.	Description	Qty.
1	FI05048	Tee	1
2	FI05132	Ballcheck Connector	1
3	SK50557	Plug, 3/4" NPT	1
4	SK00191	Oil Tank	1
5	SK50715	Motor Oil, SAE 30	1L/1 Qt.
6	FI00236	Plug, 1/4" NPT	1
7	FI00350	Reducer Bushing	1
8	FI05133	Pipe	1
9	SK50604	Bracket, Relief Valve	1
10	SK50603	Relief Valve	1
11	FA19060	Set Screw, #8-32 x 1/8"	1
12	SK00241	Push Button	1
13-14	KE00508	Hand Wheel	1
14	FA19501	Set Screw, 3/8-16 x 3/8"	1
15	SK50556	Bushing, Hand Wheel	1
16	SK50602	Hydraulic Pump	1
17	FA31009	Lockwasher, 5/16	2
18	FA20010	Hex Nut, 5/16-18	2

Use only replacement parts which are factory supplied as to preserve the certification of Underwriters Laboratories, American Gas Association, Canadian Standards Association or Canadian Gas Association (as applicable). The use of other than factory supplied replacement parts will void the warranty.

PARTS LIST - HYDRAULIC LIFT MECHANISM (AFTER APRIL 1, 1988)

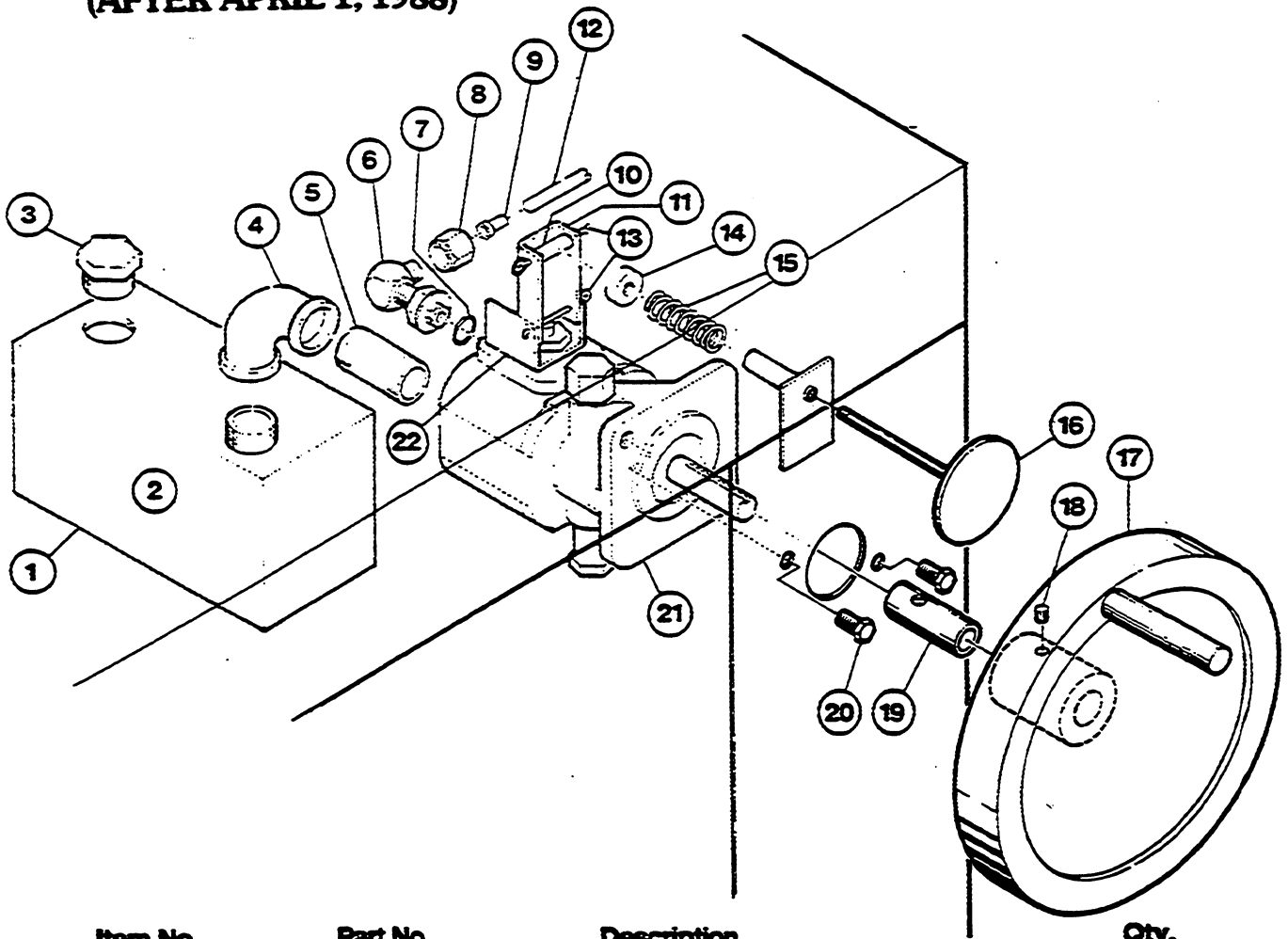

Item No.	Part No.	Description	Qty.
1	SK00191	Oil Tank	1
2	SK50715	Motor Oil, SAE 30	1L/1 Qt.
3	SK50557	Plug, 3/4" NPT	1
4	FI00051	Elbow, 1/2" NPT	1
5	FI00587	Pipe, 1/2" NPT x 2 1/2"	1
6-7	FI05140	Elbow	1
7	SE50239	"O" Ring	1
8	FI05139	Nut, 7/16 - 20 Std. Thread	1
9	FI05138	Sleeve	1
10	SK50666	Roller	1
11	SK50604	Bracket, Relief Valve	1
12	SK50628	Oil Tubing, 77" (SGL-30-X)	1
	SK50629	Oil Tubing, 88 1/4" (SGL-40-X)	1
	SK50630	Oil Tubing, 86 1/2" (SGM-30-X)	1
	SK50631	Oil Tubing, 97 3/4" (SGM-40-X)	1
13	FA95029	Cotter Pin, 1/8" Dia. x 1 1/2"	2
14	SK50667	Threaded Slug	1
15	SK50677	Spring	1
16	SK00241	Push Button	1
17-18	KE00508	Hand Wheel	1
18	FA19501	Set Screw, 3/8 - 16 x 3/8"	1
19	SK50556	Bushing, Hand Wheel	1
20	FA10753	Bolt, 3/8 - 24 x 1"	2
21	SK50679	Hydraulic Pump	1
22	SK50558	Bracket, Relief Valve	1

HYDRAULIC JACK ASSEMBLY

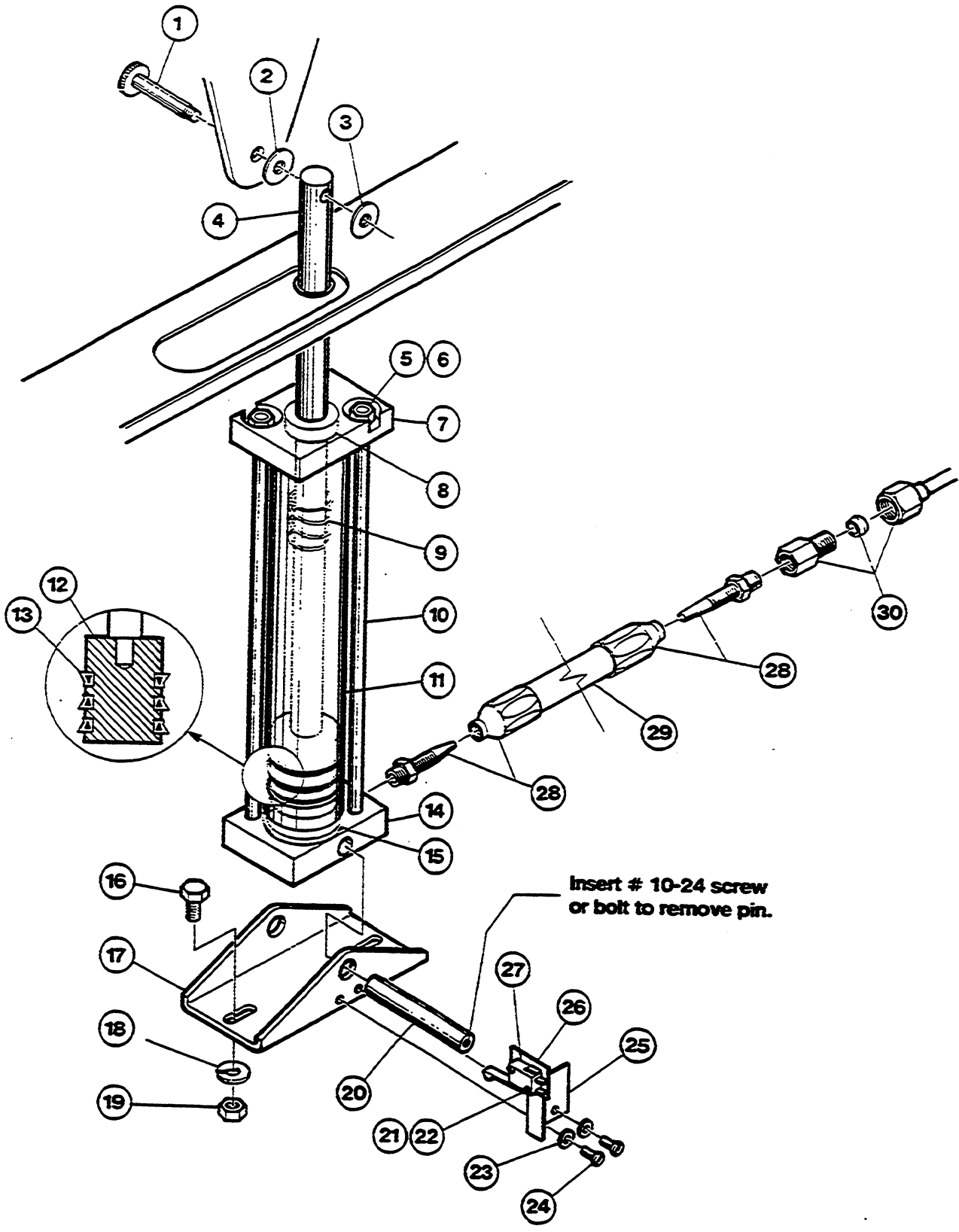

PARTS LIST - HYDRAULIC JACK ASSEMBLY

Item No.	Part No.	Description	Qty.
1	SK50605	Mounting Pin, Top Jack	1
2	SK00315	Cap. Jack	1
3	FA30006	Washer	1
4-15	SK00208	Hydraulic Jack Assembly	1
4	SK50578	Piston Rod	1
5	FA20026	Hex Nut, 1/4-20	2
6	FA32008	Lockwasher, 1/4	2
7	SK50575	Cylinder Top	1
8	SK50596	Wiper Scraper Seal	1
9	SK50711	Spring	1
10	SK50579	Tie Rod	2
11	SK50576	Cylinder	1
12	SK50574	Cylinder Piston	1
13	SK50595	Wiper Seal	3
14	SK50573	Cylinder Base	1
15	SK50597	Tetra Seal	1
16	FA10603	Bolt, 5/16 - 18 x 3/4"	2
17	SK50541	Mounting Bracket, Hydraulic Jack	1
18	FA31009	Lockwasher, 5/16	2
19	FA20010	Hex Nut, 5/16 - 18	2
20	SK50552	Mounting Pin, Bottom Jack	1
21	FA10032	Screw, #4 - 40 x 5/8"	2
22	FA32002	Tooth Lockwasher, #4	2
23	FA32006	Tooth Lockwasher, #10	2
24	FA10362	Screw, #10 - 32 x 3/8"	2
25	SK50546	Bracket, Micro Switch	1
26	KE52312	Fish Paper	1
27	SK50663	Micro Switch	1
28	FI05135	Coupling	2
29	FI05136	Hydraulic Hose, 1/4" ID x 12"	1
30	FI05134	Connector	1

Use only replacement parts which are factory supplied as to preserve the certification of Underwriters Laboratories, American Gas Association, Canadian Standards Association or Canadian Gas Association (as applicable). The use of other than factory supplied replacement parts will void the warranty.

ELECTRIC JACK ASSEMBLY

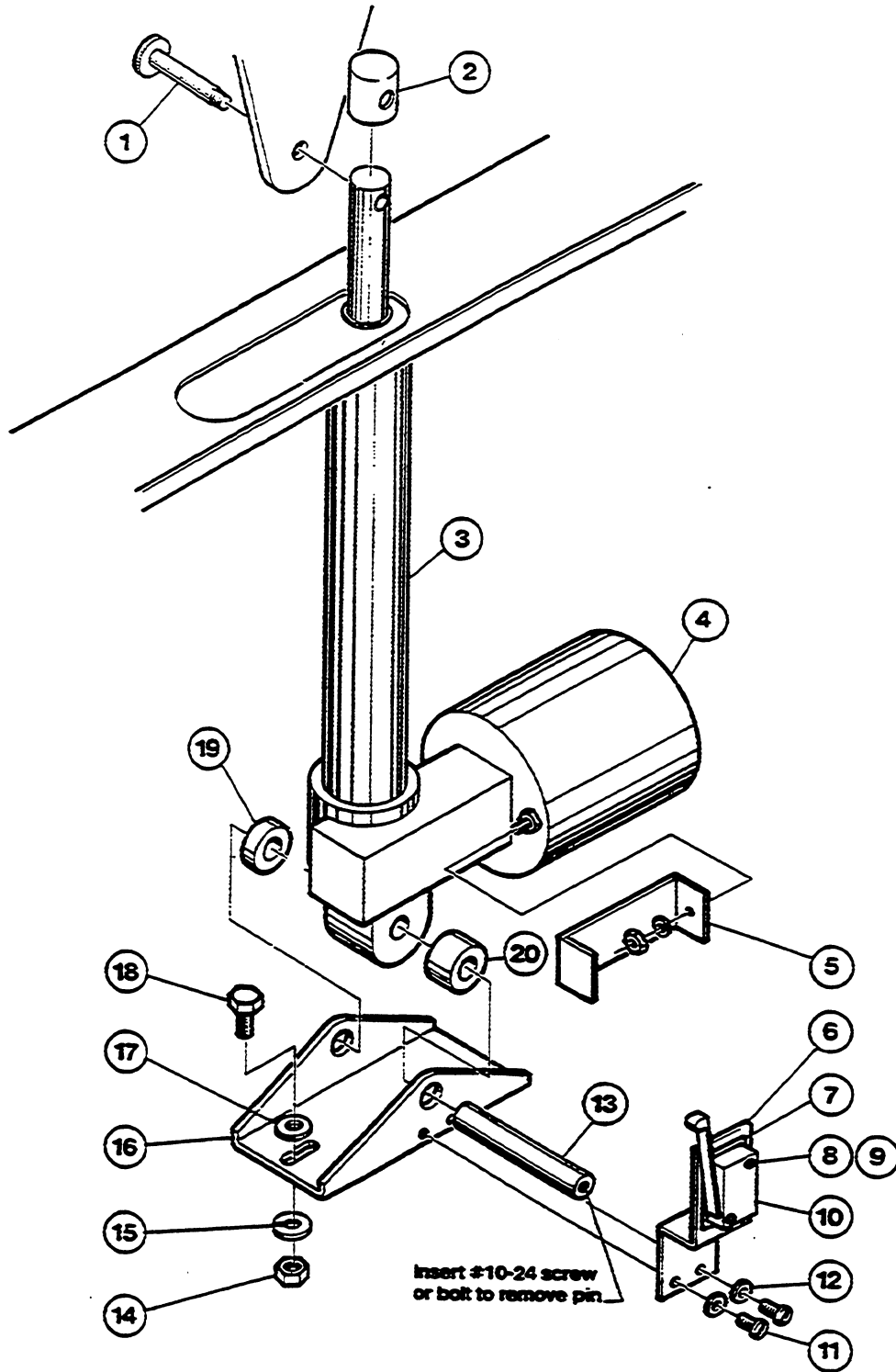

PARTS LIST - ELECTRIC JACK ASSEMBLY

Item No.	Part No.	Description	Qty.
1	SK50605	Pin, Mounting, Top Jack	1
2	SK50648	Washer	1
3-4	SK50493	Electric Jack Assembly	1
4	SE50025	Motor, Electric Jack	1
5	SK50621	Lever, Micro Switch	1
6	SK50601	Bracket, Micro Switch	1
7	KE52312	Fish Paper	1
8	FA10032	Screw, #4 - 40 x 5/8"	2
9	FA32002	Tooth Lockwasher, #4	2
10	SK50663	Micro Switch	1
11	FA10362	Screw, #10 - 32 x 3/8"	2
12	FA32006	Tooth Lockwasher, #10	2
13	SK50552	Mounting Pin, Bottom Jack	1
14	FA20010	Hex Nut, 5/16 - 18	2
15	FA31009	Lockwasher, 5/16	2
16	SK50542	Bracket, Mounting, Electric Jack	1
17	FA30078	Washer	2
18	FA10603	Bolt, 5/16 - 18 x 3/4"	2
19	SK50644	Spacer, L.H., 3/16" Thick (SGL, SGM-30-X)	1
	SK50645	Spacer, L.H., 1/4" Thick (SGL, SGM-40-X)	1
20	SK50647	Spacer, R.H., 1/2" Thick (SGL, SGM-30-X)	1
	SK50646	Spacer, R.H., 7/16" Thick (SGL, SGM-40-X)	1

Use only replacement parts which are factory supplied as to preserve the certification of Underwriters Laboratories, American Gas Association, Canadian Standards Association or Canadian Gas Association (as applicable). The use of other than factory supplied replacement parts will void the warranty.

PARTS LIST -HINGE ASSEMBLY

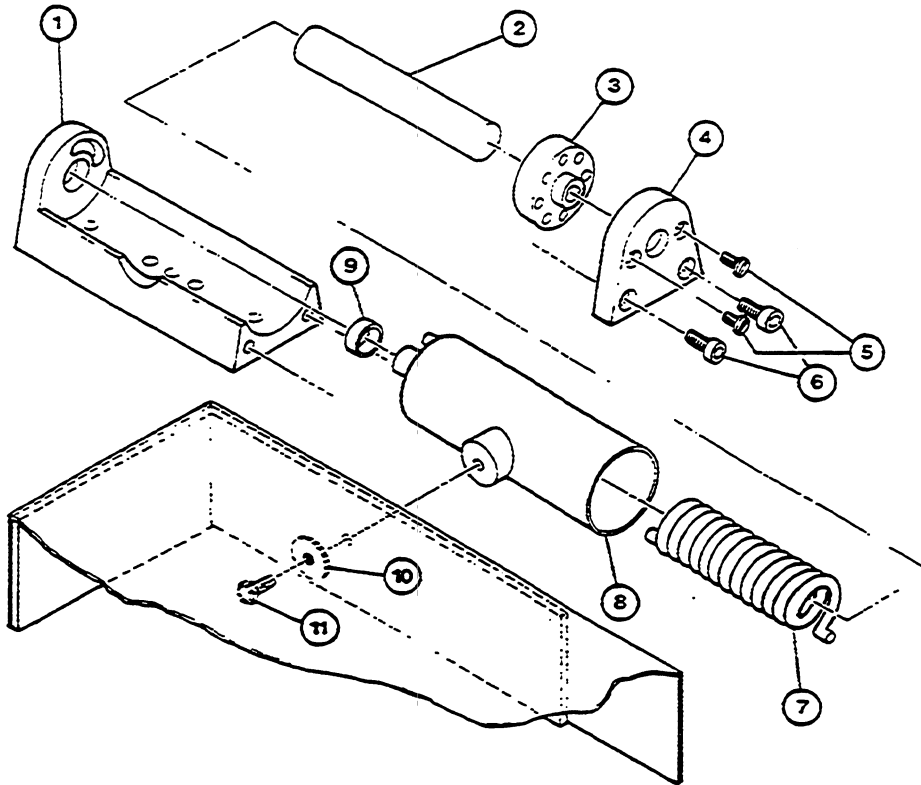

Item No.	Part No.	Description	Qty.
1-9	KE00598	Hinge Assy. (30 Gal.)	2
	SK00168	Hinge Assy. (40 Gal.)	2
1	KE51218	Body, Hinge	1
2	KE50823	Pin, Hinge	1
3	KE50820	Insert, Hinge	1
4	KE50819	End Piece, Hinge	1
5	FA11507	Screw, Tension Adjust, 10-24 x 3/4"	2
6	FA11284	Screw, End Piece, 1/4-20 x 1/2"	2
7	KE50122	Spring, Hinge (30 Gal.)	1
	KE50121	Spring, Hinge (40 Gal.)	1
8	KE51217	Cylinder, Hinge	1
9	KE50824	Bearing, Hinge	1
10	SK50209	Washer	1
11	SK00101	Bolt, 3/8-16 x 1"	1

Use only replacement parts which are factory supplied as to preserve the certification of Underwriters Laboratories, American Gas Association, Canadian Standards Association or Canadian Gas Association (as applicable). The use of other than factory supplied replacement parts will void the warranty.

PARTS LIST-COVER-VENT CAP AND DEFLECTOR

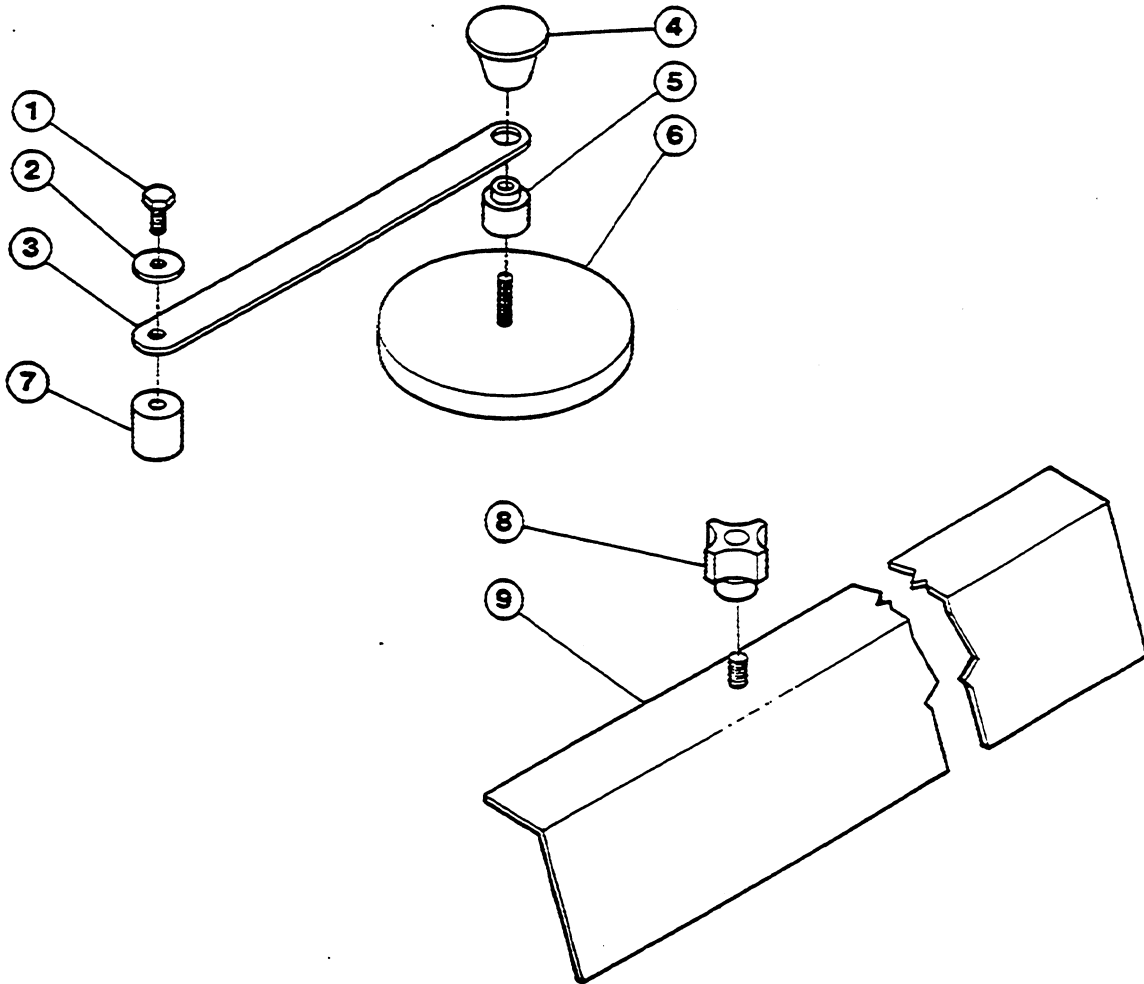

Item No.	Part No.	Description	Qty.
1	SK00105	Screw, ¼-20 x ¾"	1
2	SK50179	Washer	1
3-6	SK00054	Vent Cap Assy.	1
3	SK51032	Support Arm	1
4	SK50218	Knob	1
5	SK50131	Spacer	1
6	SK00059	Cover	1
7	SK50133	Spacer	1
8	SK50444	Knob	3, 4*
9	SK00175	Deflector Assy. (30 Gal.)	1
	SK00176	Deflector Assy. (40 Gal.)	1

*The first figure applies to 30 gal. skillets, the second figure applies to 40 gal. skillets

Use only replacement parts which are factory supplied as to preserve the certification of Underwriters Laboratories, American Gas Association, Canadian Standards Association or Canadian Gas Association (as applicable). The use of other than factory supplied replacement parts will void the warranty.

PARTS LIST - FAUCET

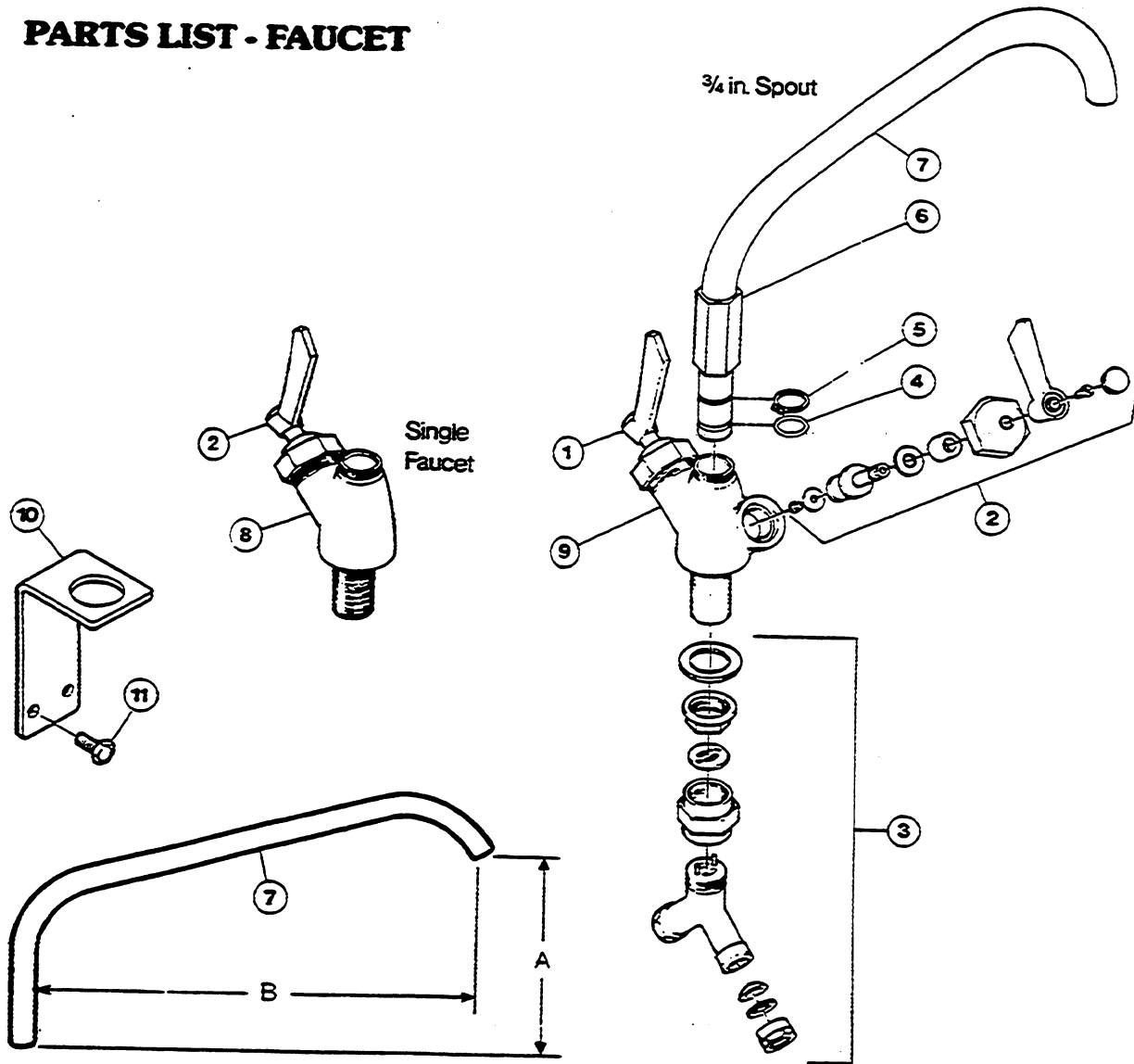

Item No.	Part No.	Description	Qty.
1	SE50020	Hot Water Stem Assy.	1
2	SE50021	Cold Water Stem Assy.	1
3	SE50022	Yoke Connection Kit	1
4	FA00016	"O" Ring	1
5	FA95022	Retaining Ring	1
6	KE51736	Spout Nut	1
7	KE50832	3/4" Spout, 10"(A) x 9"(B)	1
8	KE51401	Single Pantry Control Valve (c/w Item No. 2)	1
9	KE51403	Double Pantry Control Valve (c/w Item No. 1,2,3)	1
10	SK00212	Faucet Mounting Bracket	1
11	FA11272	Bolt, 1/4-28 UNF x 3/4"	2

Use only replacement parts which are factory supplied as to preserve the certification of Underwriters Laboratories, American Gas Association, Canadian Standards Association or Canadian Gas Association (as applicable). The use of other than factory supplied replacement parts will void the warranty.

SERVICING GUIDE

This section contains servicing information intended for use by Authorized Service Personnel. If Fault Isolation Procedure is required, be sure to start at step #1.

A/Problem: Skillet is not heating at all. (Skillet must be on, in a down position and thermostat control set).

Possible Causes

- | | |
|---|--|
| 1. No power — either gas or electric. | 8. Defective pilot flame sensor. |
| 2. Micro (cut-off) switch faulty or not activated (skillet in a tilted position). | 9. Defective pilot re-light. |
| 3. Defective on/off switch. | 10. Defective cycling pilot safety timer. (Spark ignition) |
| 4. Defective control thermostat. | 11. Defective or incorrectly adjusted gas control valve. |
| 5. Defective safety thermostat. | 12. Blown 4/10, 1½, or 10 amp fuse. |
| 6. Defective 208-240/120 VAC transformer. (208-240V units) | 13. Incorrect spark gap. (Spark ignition) |
| 7. Defective 120/25 VAC transformer. | 14. Poor ground. |
| | 15. Faulty wiring. |
-

Fault Isolation Procedure

Step	Test	Result	Remedy
1.	Are both electrical and gas supplies available to unit?	Yes	Go to step #2.
		No	Correct external power supply problem.
2.	Is the main power (lower) pilot light illuminated?	Yes	Go to step # 6.
		No	Go to step # 3.
3.	Is the 4/10 amp fuse (manual ignition), 1½amp fuse (spark ignition) or 10 amp fuses (208-240V units) blown?	Yes	Replace blown fuse.
		No	Go to step # 4.
4.	On 120V units, go to step # 5. On 208-240V units, is there 120 VAC present at the output of the 208-240/120 VAC transformer?	Yes	Go to step # 5.
		No	Replace defective 208-240/120 VAC transformer.
5.	Is there 25 VAC present at the output of the 120/25 VAC transformer?	Yes	Replace defective on/off switch.
		No	Replace defective 120/25 VAC transformer.
6.	Is the operating (upper) pilot light illuminated?	Yes	Go to step # 9.
		No	Go to step # 7.
7.	Is there 25 VAC across the tilt safety switch?	Yes	Adjust or replace defective tilt safety switch.
		No	Go to step # 8.
8.	Is there 25 VAC across the control thermostat?	Yes	Replace defective control thermostat.
		No	Replace defective high limit thermostat.
9.	It is assumed that there is proper operating incoming gas pressure of minimum 7" WC for natural gas and 12" WC for LP gas. For manual ignition, go to step #10. For spark ignition natural gas, go to step #12. For spark ignition LP gas, go to step # 17.		

10.	Can a pilot light be achieved?	Yes	Refer to Pilot Flame Adjustment Procedure and adjust flame if necessary. If adjustment is not required or unsuccessful, go to step #11.
		No	Replace defective gas control valve.
11.	Does the pilot flame sensor (thermopile) generate 450-750 mV?	Yes	Replace defective gas control valve.
		No	Replace defective pilot flame sensor.
12.	Look through peep hole. Can a pilot flame be achieved?	Yes	Go to step # 16.
		No	Go to step # 13.
13.	Is a spark being generated?	Yes	Go to step # 15.
		No	Go to step # 14.
14.	Is the spark gap $1/8" \pm 1/32"$?	Yes	Replace defective pilot re-light.
		No	Adjust spark gap.
15.	Measure continuity across pilot flame sensor's pins #3 and #4. Is it a closed circuit?	Yes	Replace defective gas control valve.
		No	Replace defective pilot flame sensor.
16.	After pilot has been lit for 5 minutes, pull pilot flame sensor's connection off and quickly measure continuity between pins #2 and #4. Is it a closed circuit at first and after pilot flame sensor cools down the circuit opens?	Yes	Replace defective gas control valve.
		No	Refer to Pilot Flame Adjustment Procedure and adjust flame if necessary. If adjustment is not required or unsuccessful, replace defective pilot flame sensor.
17.	Look through peep hole. Is a spark being generated?	Yes	Go to step # 19.
		No	Go to step # 18.
18.	Is the spark gap $1/8" \pm 1/32"$?	Yes	Replace defective pilot re-light.
		No	Adjust spark gap.
19.	Turn power on/off switch to "off" for 5 minutes. This will zero the cycling pilot safety timer. Then turn unit back on. Is a pilot flame now available?	Yes	If burners now fail to ignite, go to step #21.
		No	Go to step # 20.
20.	Measure continuity across pilot flame sensor's pins #3 and #4. Is it a closed circuit?	Yes	Replace either defective cycling pilot safety timer or gas control valve. (Note: Gas control valve would be the more reliable component)
		No	Replace defective pilot flame sensor.
21.	After pilot has been lit and just as pilot goes out due to cycling pilot safety timer, pull pilot flame sensor's connection off and quickly measure continuity between pins #2 and #4. Is it a closed circuit at first and after pilot flame sensor cools down the circuit opens?	Yes	Replace defective gas control valve.
		No	Refer to Pilot Flame Adjustment Procedure and adjust flame if necessary. If adjustment is not required or unsuccessful, replace defective pilot flame sensor.

B/Problem: Skillet heats too slowly or not hot enough. (Note: Maximum surface temp. is 425°F).

Possible Causes

1. Low incoming gas pressure.
2. Defective or incorrectly adjusted gas control valve.
3. Defective or incorrectly adjusted control thermostat.
4. Defective or incorrectly adjusted safety thermostat.

Fault Isolation Procedure

Step	Test	Result	Remedy
1.	Tilt skillet fully forward and manually activate the tilt safety switch. Inspect the burner flame for a period of 4 or 5 minutes. Is the burner flame strong and constant?	Yes	Go to step # 3.
		No	Go to step # 2.
2.	There is an operating gas supply problem, either incoming or outgoing. Refer to Pilot Flame Adjustment and Gas Pressure Adjustment Procedure. If this does not correct the problem, check incoming operating gas supply. It should be minimum 7" WC natural gas or 12" WC LP gas. If gas pressure is correct, replace defective gas control valve.		
3.	In an operating situation and with control thermostat set at #10, does the operating (upper) pilot light go out too early? (Burners shut off too early)	Yes	Go to step # 4.
		No	Go to step # 2.
4.	Immediately after operating (upper) pilot goes out, turn control thermostat to #1. Can you hear or feel the thermostat "clicking" off?	Yes	Adjust or replace safety thermostat (adjust to 470°F)
		No	Adjust or replace control thermostat (adjust to approx. 425°F)

C/Problem: Skillet is overheating.

Replace or adjust control thermostat. (adjust to approx. 425°F) Verify that the safety thermostat shuts off at approx. 470°F.

D/Problem: Skillet fails to tilt (Power tilt units) (Note: A thermal overload in jack motor does not allow constant consecutive tilting)

Possible Causes

1. No electrical power to the skillet.
2. Defective rocker (up-down) switch.
3. Defective start capacitor.
4. Blown 10 amp fuse. (208-240V units)
5. Defective 208-240/120 VAC transformer. (208-240V units)
6. Defective power jack.

Fault Isolation Procedure

Step	Test	Result	Remedy
1.	Is there electrical power to the skillet?	Yes	Go to step #2.
		No	Correct external power supply problem.
2.	On 120V units, go to step #4. On 208-240V units, is either one of the 10 amp fuses blown?	Yes	Replace blown fuse.
		No	Go to step # 3.
3.	Is there 120 VAC present at output of 208-240/120 VAC transformer?	Yes	Go to step # 4.
		No	Replace defective 208-240/120 VAC transformer.
4.	Test rocker switch for continuity. Is it operating properly?	Yes	Go to step # 5.
		No	Replace defective rocker switch.
5.	Remove motor from power jack. Activate tilt switch. Does the motor rotate?	Yes	Replace defective power jack.
		No	Go to step # 6.
6.	Remove power jack wiring from connections. Measure resistance across each of the three wires. Do they read (approx.) 14 ohms between black and white, 29 ohms between black and red, and 14 ohms between red and white?	Yes	Replace defective start capacitor.
		No	Replace defective motor.

GAS PRESSURE ADJUSTMENT PROCEDURE

CAUTION: The following procedure, as well as other work on gas controls should be performed only by a qualified service technician.

NOTE: Gas pressure adjustment is pre-set and rarely needs any adjustment.

1. Remove gas pressure adjustment cover screw.
2. Operating gas pressure output should be regulated to 6"W.C. natural gas and 11"W.C. LP gas.
3. Turn gas pressure adjustment screw (under cover screw) clockwise to increase or counterclockwise to decrease gas pressure.
4. Replace cover screw.

PILOT FLAME ADJUSTMENT PROCEDURE

CAUTION: The following procedure, as well as all other work on gas controls should be performed only by a qualified service technician.

1. Remove pilot adjustment cover screw.
2. Turn pilot flow adjustment screw (under cover screw) clockwise to increase flame (see below drawing for correct flame adjustment).
3. Replace cover screw.

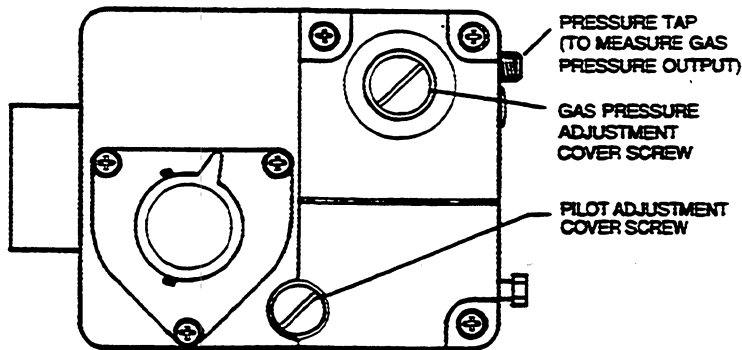

COMBINATION CONTROL VALVE

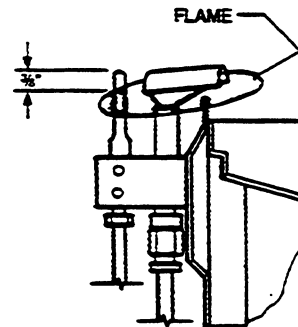

PILOT GENERATOR

HYDRAULIC JACK REPLACEMENT PROCEDURE

Refer to "Hydraulic Jack Assembly" drawing.

1. Place skillet pan in a down position.
2. Remove jack's top mounting pin (1).
3. Remove micro switch bracket (25) by removing screws (24).
4. Insert a #10-24 screw or bolt into jack's bottom mounting pin (20) and pull pin away from jack to remove.
5. Disconnect hydraulic hose (28, 29) at connector (30).
6. Remove jack from skillet.
7. Disconnect hydraulic hose from old jack and connect to new jack.
8. Ensure replacement jack is in a down position and place end of hydraulic hose into pump's oil tank by removing $\frac{3}{4}$ " plug. Draw out jack's piston rod so that oil is drawn into hydraulic hose.
9. Remove hose from tank and turn jack upside down. Push in on the jack's piston rod. Oil with air bubbles will seep out the end of the hydraulic hose. Continue pushing down on the rod until all air bubbles stop and only oil is being emitted.
10. Follow steps 1 through 6 in reverse order to re-assemble.

NOTE: If alot of oil has been lost, check oil level in oil tank. It should be filled to approximately $\frac{1}{2}$ " from top of tank with standard motor oil (SAE-30).

POWER JACK REMOVAL PROCEDURE

WARNING: Skillet pan is heavy and support should always be given to pan if jack is being removed.

1. Remove top jack mounting pin.
2. Remove bottom jack mounting pins retaining bracket.
3. Remove bottom jack mounting pin by inserting a #10-24 screw or bolt into the pin and pulling towards the interior of the skillet.
4. There should now be plenty of clearance to remove jack.

HYDRAULIC PUMP REPLACEMENT AND AIR BLEEDING PROCEDURE (units after April 1, 1988)

NOTE: Bleeding the pump of air is necessary if air has entered hydraulic lines, jack, or pump. If pump is not being replaced omit step #6.

Refer to "Hydraulic Lift Mechanism" drawing.

1. Place skillet pan in a down position.
2. Remove hand wheel (17) by loosening set screw (18).
3. Remove hydraulic line nut (8) from elbow (6).
4. Remove bolts (20) that secure pump to frame.
5. Remove pump (21) from unit.
6. Remove oil tank (1) from old pump and re-connect onto new pump. Pour oil out of old tank and into new tank.
7. Tilt oil tank up at back so that oil flows toward pump.
8. Turn pump shaft counter-clockwise until oil starts to seep out of elbow.
9. Set pump and oil tank down so that oil tank is sitting flat on surface. Support pump so that it will not tip forward.
10. Turn pump shaft counter-clockwise while applying slight pressure with finger on opening of elbow. Oil and air bubbles should seep out. Continue to do this until all air bubbles stop and only oil is being emitted.
11. Re-install pump into unit securing with mounting bolts.
12. Re-connect hydraulic line to elbow.
13. Re-install hand wheel.

NOTE: If alot of oil has been lost, check oil level in oil tank. It should be filled to approximately $\frac{1}{2}$ from top of tank with standard motor oil (SAE-30).

HINGE ADJUSTMENT INSTRUCTIONS

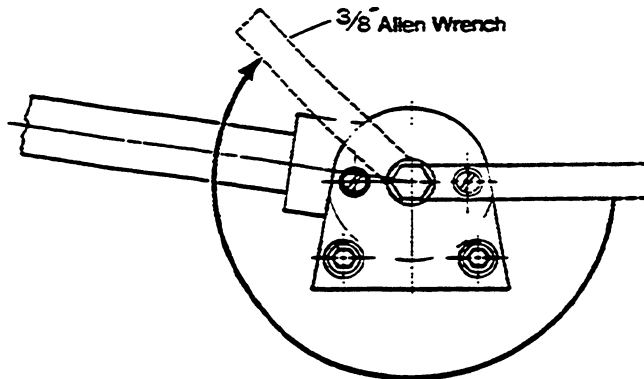

1. Insert $\frac{3}{8}$ " Allen wrench.
2. Turn clockwise to relieve tension on spring.
3. While tension is released remove one of the two slotted screws.
4. To prevent Allen wrench from springing back abruptly while the second slotted screw is removed, insert a pin (approximately $\frac{1}{8}$ ") in the hole where the first slotted screw was removed from.
5. Remove second slotted screw.
6. While holding Allen wrench remove pin.
7. Turn Allen wrench clockwise to tighten or counter-clockwise to loosen tension to produce desired effect.
8. Re-insert pin in one of the two holes.
9. Tighten one slotted screw in the other hole (it may be necessary to turn Allen wrench slightly to align holes.)
10. Remove pin and repeat step number 9 for other slotted screw.

WIRING DIAGRAM - SPARK IGNITION

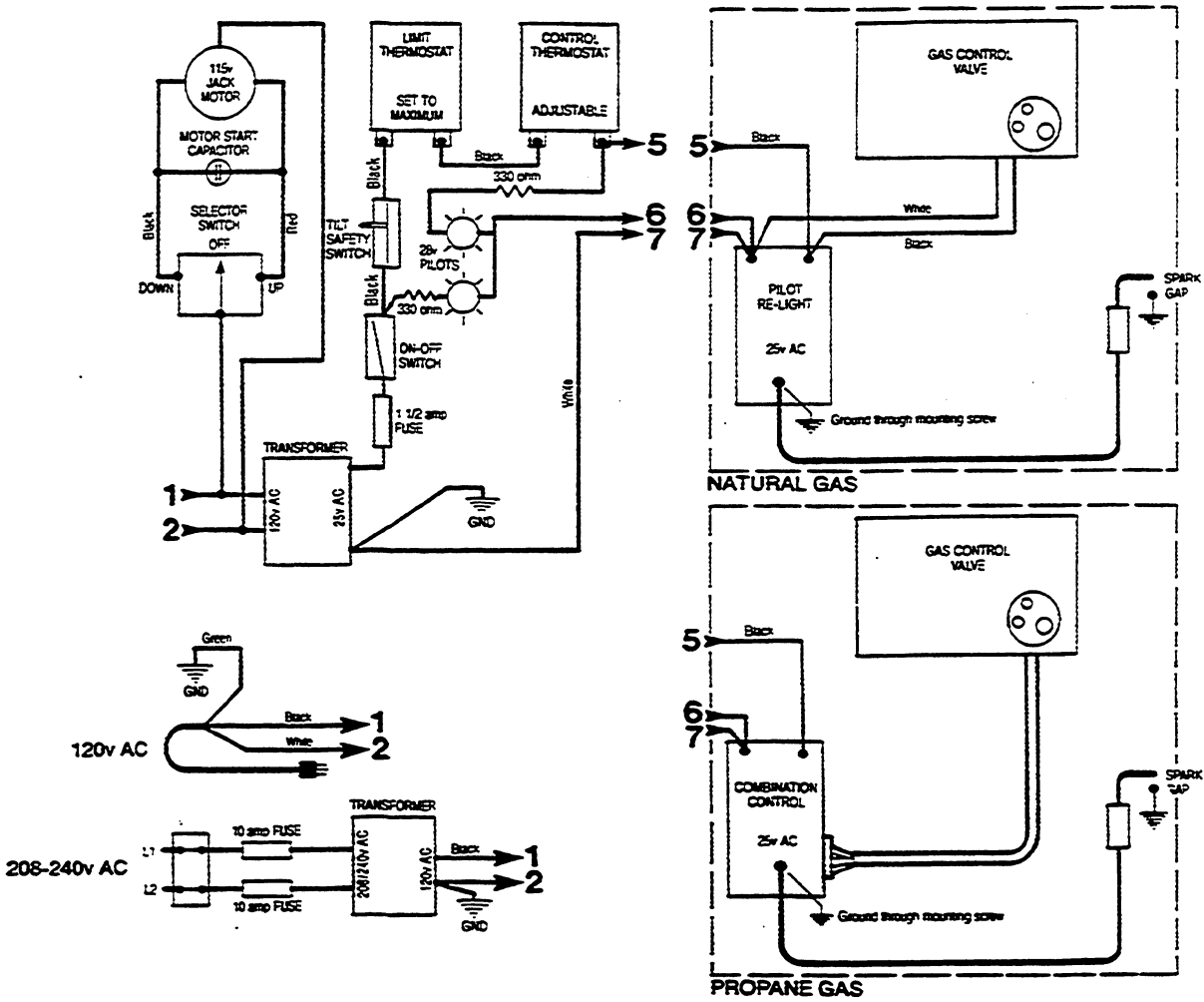

WIRING DIAGRAM - MANUAL IGNITION

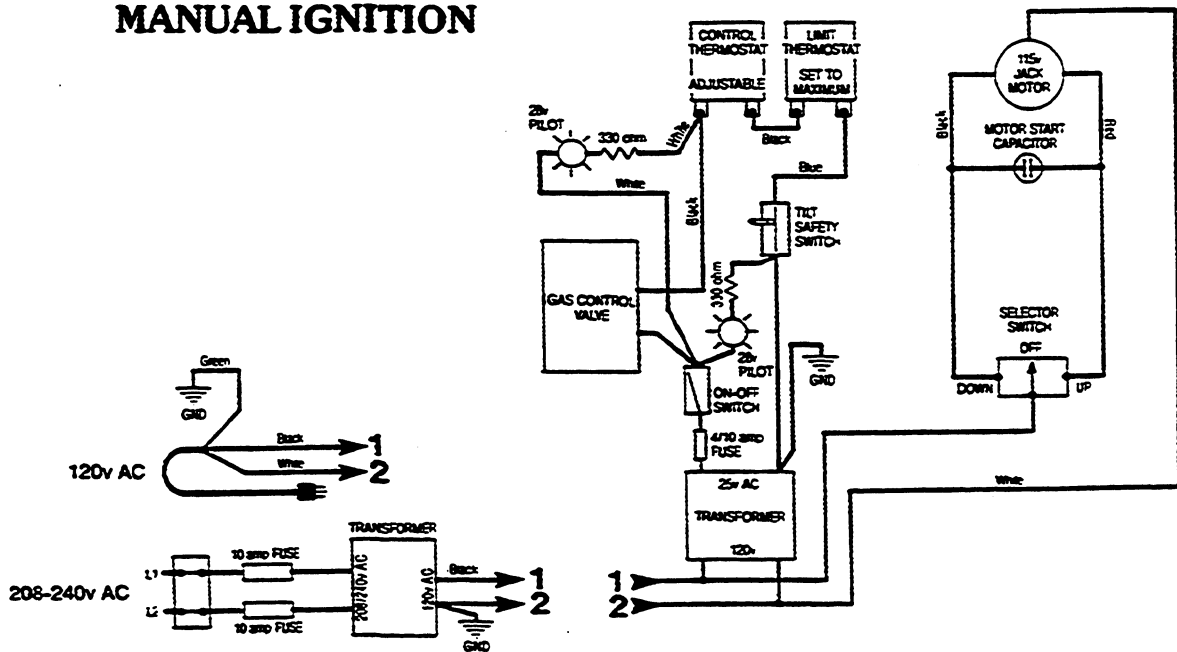

Notes

