



Operators Manual

Installation, Operation & Service

Skillets

OPEN BASE & MODULAR GAS SKILLETS -

MODELS

SGL-30-TR SGM-30-TR
SGL-40-TR SGM-40-TR

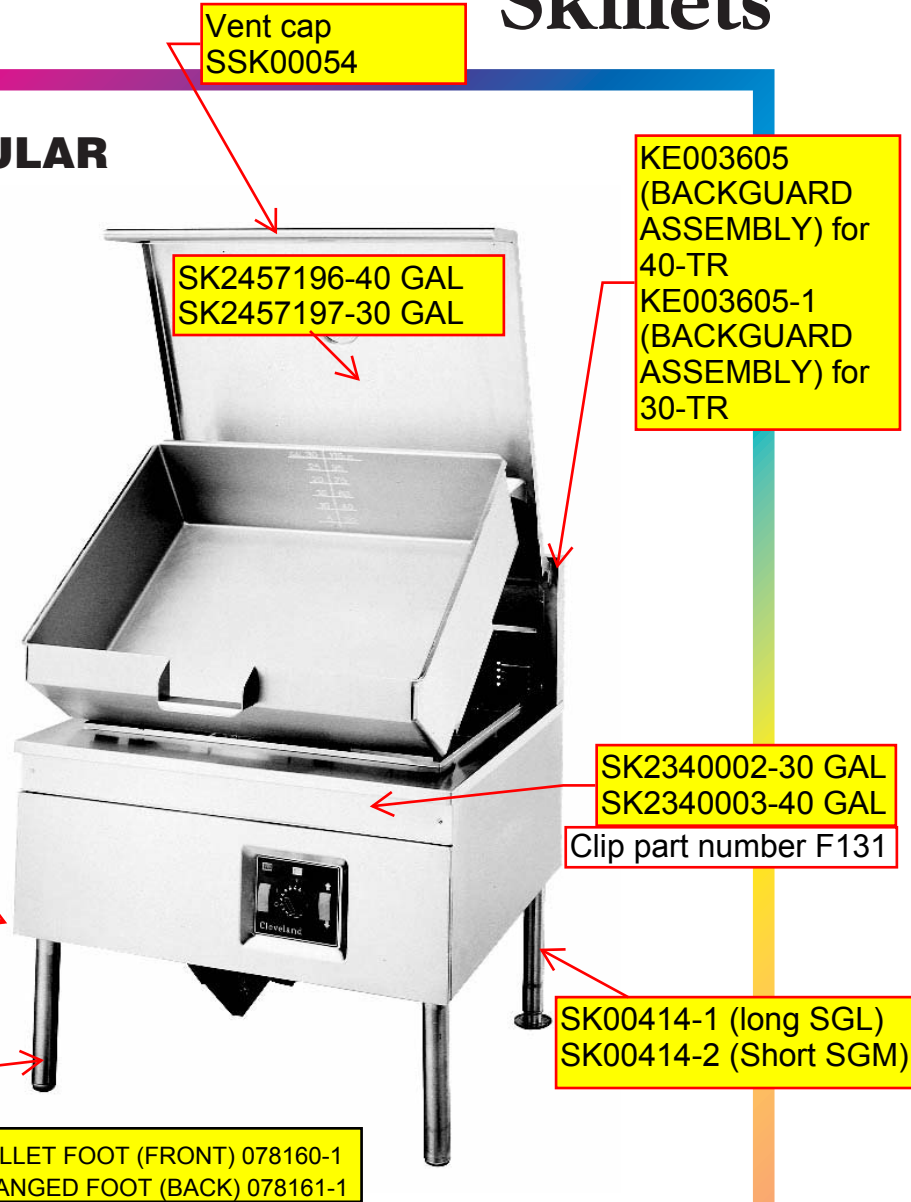

SIDE PANEL
SK2336800; SEL/SGL-TR
SK2336801; SGM/SEM-TR

SK2355200 HINGE WELDED
SK2355201 HINGE BOLTED

SK2335499

BULLET FOOT (FRONT) 078160-1
FLANGED FOOT (BACK) 078161-1

Vent cap
SSK00054

SK2457196-40 GAL
SK2457197-30 GAL

KE003605
(BACKGUARD
ASSEMBLY) for
40-TR
KE003605-1
(BACKGUARD
ASSEMBLY) for
30-TR

SK2340002-30 GAL
SK2340003-40 GAL

Clip part number F131

SK00414-1 (long SGL)
SK00414-2 (Short SGM)



1333 East 179th St., Cleveland, Ohio, U.S.A. 44110

Enodis

Phone: (216) 481-4900 Fax: (216) 481-3782
Visit our web site at www.clevelandrange.com

FOR THE USER

FOR YOUR SAFETY

DO NOT STORE OR USE GASOLINE OR ANY OTHER FLAMMABLE LIQUIDS AND VAPOURS IN THE VICINITY OF THIS OR ANY OTHER APPLIANCE.

WARNING: Improper installation, adjustment, alteration, service or maintenance can cause property damage, injury or death. Read the Installation and Operating instructions thoroughly before installing or servicing this equipment.

IMPORTANT

Post in a prominent location, instructions to be followed in the event the user smells gas. This information shall be obtained by consulting your local gas supplier.

Keep appliance area free and clear from combustibles.

Do not obstruct the flow of combustion and ventilation air.

All service must be performed by a qualified cleveland range technician.

For unit equipped with casters, the installation shall be made with a connector that complies with the *Standard for Connectors for Movable Gas Appliances, ANSI Z21.69* or *Connectors for Moveable Gas Appliances, CAMCGA-6.16*, and a quick-disconnect device that complies with the *Standard for Quick Disconnect Devices for Use With Gas Fuel, ANSI Z21.41*, or *Quick Disconnect Devices for Use with Gas Fue4 CANT-6.9*. Adequate means must be provided to limit the movement of the appliance without depending on the connector and the quick-disconnect device or its associated piping to limit the appliance movement. A restraint can be attached to the rear leg next to the gas connection.

For Australia, the equipment must be installed by an authorized person in accordance with AS 5601, local authority, gas, electricity, any applicable statutory regulations and manufacturer requirements.

RETAIN THIS MANUAL FOR YOUR REFERENCE.

For your safety

DANGER



Keep hands and utensils away from moving parts and pinch points.

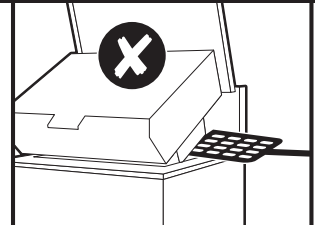
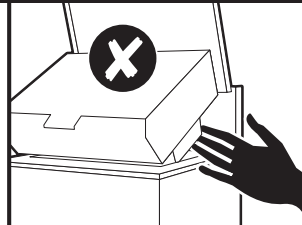

IMPORTANT



Inspect unit daily for proper operation.

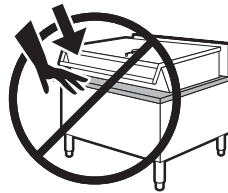

Do not lean on or place objects on skillet lip.



Lift lid before tilting skillet.

CAUTION

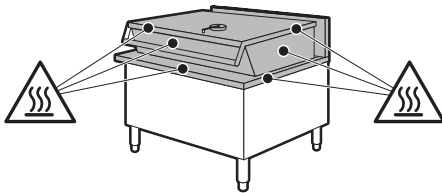

Surfaces may be extremely hot! Use protective equipment.

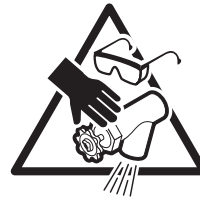

Wear protective equipment when discharging hot product.

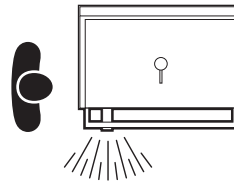

Stand clear of product discharge path when discharging hot product.

SERVICING

WARNING: Improper installation, adjustment, alteration, service or maintenance can cause property damage, injury or death. Read the installation, operating and maintenance instructions thoroughly before installing or servicing this equipment.

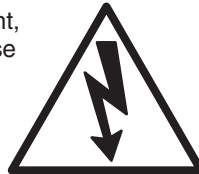

Shut off power at main fuse disconnect prior to servicing.



Ensure skillet is at room temperature prior to servicing.

GAS APPLIANCES

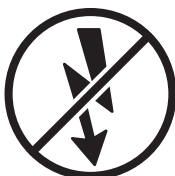

Do not attempt to operate this appliance during a power failure.



Keep appliance and area free and clear of combustibles.

INSTALLATION

GENERAL

Installation of the unit must be accomplished by qualified installation personnel working to all applicable local and national codes. Improper installation of unit could cause injury or damage.

This equipment is built to comply with applicable standards for manufacturers. Included among those approval agencies are: UL, A.G.A., NSF, ASME/N.Bd., CSA, CGA, ETL, and others. Many local codes exist, and it is the responsibility of the owner/installer to comply with these codes.

The rating plate is located directly behind the upper front panel (left side). For easy access, remove the two screws securing the upper front panel and hinge the lower front panel downwards. Gas type, burner ratings and electrical requirements are stated on the plate.

Observe all clearance requirements to provide proper make-up air flow. Do not obstruct the flow of combustion and ventilation air. Check rating plate to ensure that unit has been equipped to operate with the type of gas available at the installation.

All units are protected with fuses which are located inside the service box. For easy access, hinge front panel downwards.

A pressure tap is supplied with each unit and is installed on the manifold. The gas pressure must be checked when unit is installed, to ensure unit gas pressure is the same as specified on the rating plate. For access to the pressure tap, remove front panel, turn power switch to the 'OFF' position as a precaution and hinge front panel downwards. The pressure tap is located behind the front shield. If necessary, pressure adjustments can be made at the pressure regulator which is installed on the manifold. For easy access to the pressure regulator, view along left side of unit from underneath. Once pressure test is completed, turn power switch and thermostat to the 'OFF' position. Raise lower front panel back into position.

Make certain that new piping, joints and connections have been made in a clean manner and have been purged, so that piping compound, chips, etc., will not clog valves and/ or controls. Use pipe joint sealant that is approved for use with liquefied petroleum gas.

Have a qualified gas technician check the gas pressure to make certain that existing gas facilities (meter, piping; etc.) will deliver the BTU's of gas required at the unit with no more than 1/2" water column pressure drop. When checking pressure, be certain that all the equipment on the same gas line is turned to the 'ON' position.

WARNING: Always check gas connections for leaks using soap solution or similar means. **DO NOT CHECK WITH AN OPEN FLAME.**

INSPECTION

Before unpacking visually inspect the unit for evidence of damage during shipping.

If damage is noticed, do not unpack the unit, follow shipping damage instructions.

SHIPPING DAMAGE INSTRUCTIONS

If shipping damage to the unit is discovered or suspected, observe the following guidelines in preparing a shipping damage claim.

1. Write down a description of the damage or the reason for suspecting damage as soon as it is discovered. This will help in filling out the claim forms later.
2. As soon as damage is discovered or suspected, notify the carrier that delivered the shipment.
3. Arrange for the carrier's representative to examine the damage.
4. Fill out all carrier claims forms and have the examining carrier sign and date each form.

CLEARANCE REQUIREMENTS/ DRAIN LOCATIONS

This unit must be installed in accordance with the clearances shown on the rating label which is adhered to the unit.

FOR YOUR SAFETY. Keep the appliance area free and clear of combustible materials.

VENTILATION

These units must be installed under an adequate ventilation system.

INSTALLATION

KEEP THE APPLIANCE AREA FREE AND CLEAR OF COMBUSTIBLE MATERIALS.

1. Carefully remove unit from carton or crate. Remove any packing material from unit.
2. A protective material has been applied to the stainless steel panels.
NOTE: This material must be removed immediately after installation, as heat will melt the material and make it difficult to remove.
3. Position the unit in its permanent location.
4. Level skillet by means of adjustable stainless steel feet. Use a spirit level and level unit four ways; across front and back and down left and right edges.
5. Once positioned and leveled, permanently secure the unit's flanged feet to the floor using 5/16" lag bolts and floor anchors (supplied by the installer). Three bolts are required to secure each of the flanged feet.
6. Seal joints of flanged feet with a silicone sealant.

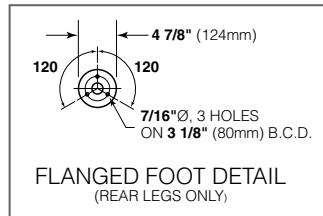

GAS

ENSURE THE GAS SUPPLY MATCHES THE SKILLET'S REQUIREMENTS AS STATED ON THE RATING PLATE.

A 3/4" NPT gas connection is required along the left side of the unit.

It is recommended that a sediment trap (drip leg) be installed in the gas supply line. If the gas pressure exceeds 14" water column, a pressure regulator must be installed, to provide a maximum of 14" water column gas pressure to the gas control valve.

Connect the gas supply piping. Location and pressure data are shown on the specification sheet.

Installation must be in accordance with local codes and/or the National Fuel Gas Code ANSI Z233.1-latest edition (USA) or Installation Codes for Gas Burning Appliances and Equipment CAN/CGA-B 149.1 and B 149.2 (Canada). Use a gas pipe joint compound which is resistant to L.P gas. Test all pipe joints for leaks with soap and water solution. Ensure that the gas pressure regulator is set for the manifold pressure indicated on the gas rating plate.

The appliance and its individual shut-off valve must be disconnected from the gas supply piping system during any pressure testing of that system at test pressures in excess of 1/2 psi (3.45 kPa). The appliance must be isolated from the gas supply piping system by closing its individual manual shut-off valve during any pressure testing of the gas supply piping system at test pressures equal to or less than 1/2 psi (3.45 kPa).

VENTILATION

A gas skillet must be installed in a location in which the facilities for ventilation permit satisfactory combustion of gas and proper venting. Proper ventilation is imperative for good operation of the appliance. The ideal method of ventilating a gas skillet is the use of a properly designed ventilating canopy, which should extend at least 6" (152mm) beyond all sides of the appliance (except against a wall, if the canopy is a wall installation). This is usually part of a mechanical exhaust system.

Further information can be obtained by referring to the U.S.A. National Fire Protection Association's NFPA96 regulations. These standards have also been adopted by the National Building Code in Canada.

AIR SUPPLY

Unit shall be located so as not to interfere with proper circulation of air within the confined space. All gas burners require sufficient air to operate.

Large objects should not be placed in front of the unit which might obstruct the air flow through the front. Do not obstruct the flow of combustion and ventilation air.

Do not permit fans to blow directly at the unit and wherever possible avoid open windows adjacent to the appliance sides and back; also wall type fans which create air crosscurrents within the room.

ELECTRICAL

A cord and plug is supplied on each unit, 120 volts, single phase, 1.0 amps.

WARNING: Electrical Grounding Instructions:

This appliance is equipped with a three prong (grounding) plug for your protection against shock hazard and should be plugged directly into a properly grounded three prong receptacle. Do not cut or remove the grounding prong from this plug.

A separate 15 amp service must be provided. For 120V usage, each skillet is electrically equipped with a cord set with a three prong plug which fits any standard 120 volt three prong grounded receptacle.

When a unit is ordered and built for 208/240 volt, the supply line must be connected to the wiring terminations located inside the terminal box. For ease in attaching the supply line, there is a removable cover on the terminal box. A wiring diagram is attached to the rear panel of each unit.

IMPORTANT: This appliance must be electrically grounded in full accordance with local codes, or in the absence of local codes, with the Canadian Electrical Code C22.1 or with the National Electrical Code, ANSI/NFPA No. 70-latest edition (whichever is applicable).

WATER CONNECTIONS (OPTIONAL)

A 3/8" NPT cold water line and a 3/8" NPT hot water line are required for the fill faucet.

CLEANING

After installation the unit must be thoroughly cleaned and sanitized prior to cooking.

OPERATING INSTRUCTIONS

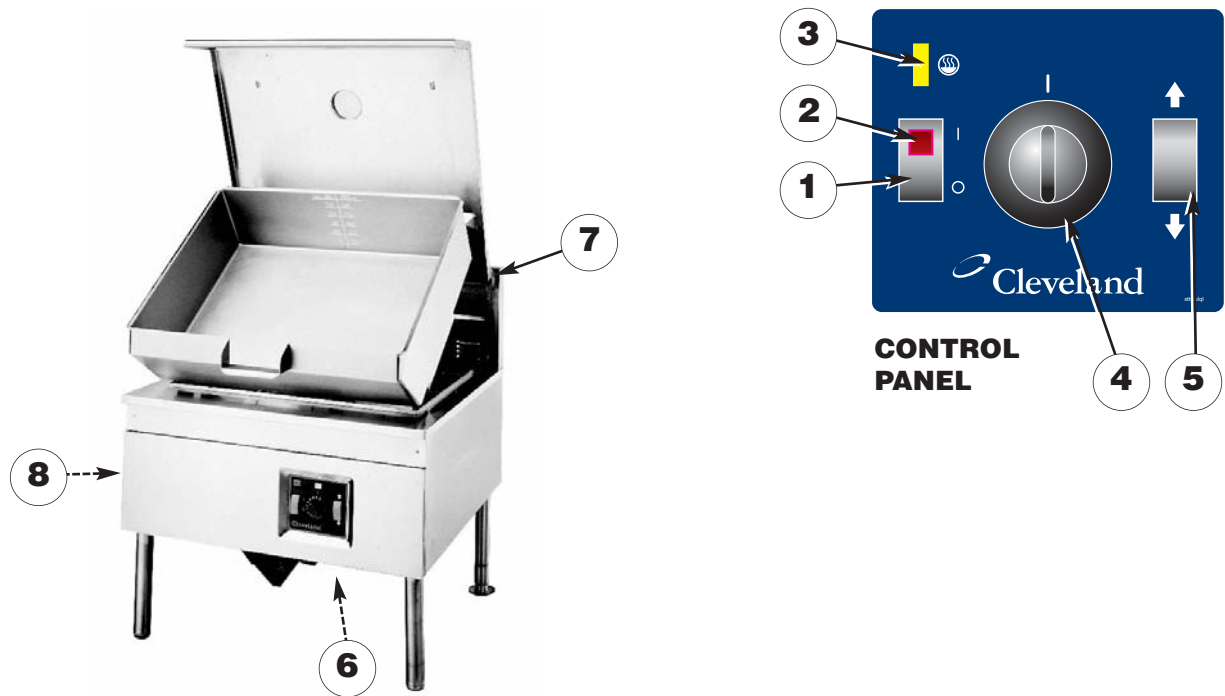

ITEM #	DESCRIPTION	FUNCTION
1.	On-Off Switch	Main power switch for unit.
2.	Power Indicator Light (Red)	Indicates power is on.
3.	Heat Indicator Light (Yellow)	Turns ON when system is calling for heat and OFF when system is satisfied.
4.	Temperature Dial	Regulates the surface temperature of the pan.
5.	Power Tilt Switch	Used for tilting the pan up or down. Some models have a Hand Tilt Wheel.
6.	Manual Tilt Override	Used on units with Power Tilt for tilting the pan up or down in case of power or mechanical failure.
7.	Flue	
8.	Gas Shut Off Valve	Allows you to shut the gas off to the appliance if required.
9.	Tangent Draw-Off Valve (not shown)	Option - Used for draining product or wash water from kettle.
10.	Faucet (not shown)	Option - hot and/or cold faucet mounts to skillet for convenient filling of the pan.

START UP PROCEDURE

This appliance has been factory tested and adjusted under ideal conditions but, rough handling, low gas pressure, altitude or variations in gas characteristics may require fine adjustment.

All units are equipped with fixed orifices and do not require primary air adjustment.

LIGHTING INSTRUCTIONS

NOTE: This appliance is equipped with a direct spark ignition system. Ensure gas and electrical supply to the appliance, are in the 'ON' position.

1. Turn the main manual gas shut-off valve to the 'ON' position.
2. Turn power switch to the 'ON' position.
3. Set thermostat to desired temperature.
4. If ignition fails and/or the control system goes into lockout, set power switch to the 'OFF' position.
5. Wait 5 minutes then repeat steps 1 through 3. If the problem persists, have a qualified serviceman check the system.
6. To shutdown system, turn power switch and main manual gas valve to the 'OFF' position.

OPERATING INSTRUCTIONS

1. Ensure gas and electrical supply to the appliance are in the 'ON' position.
2. Turn power switch to the 'ON' position. The green pilot light will indicate power is on. Wait one minute to allow flame sensor to heat up.

3. TILTING OPTIONS

Note: Before tilting the pan make sure the lid is open.

PowerTilt

Cleveland skillets are equipped with an electric power tilt mechanism for raising and lowering the frypan. To raise frypan, raise the cover and press up on the tilt switch. To lower frypan, press down on the tilt switch.

Manual Tilt

Cleveland skillets can also be equipped with the optional manual tilt mechanism for raising and lowering the frypan. To raise frypan, raise the cover and turn the wheel clockwise. To lower frypan, push in on the lever located behind the wheel.

4. **FOR YOUR SAFETY**, this skillet is also equipped with a power interrupter which automatically shuts off the gas supply to the burners whenever the skillet is raised more than 1/2" (13mm).

5. Turn power switch to the 'OFF' position when skillet is not in use.
6. During an electrical power interruption, turn power switch to the 'Off' position. This unit cannot be made to operate without electrical power or gas supply.

OPERATING SUGGESTIONS

IMPORTANT: Always raise the spring assist cover before activating the tilt mechanism. Before commencing to cook, ensure frypan is in the lowered position by pressing down on the tilt switch.

1. To preheat, set thermostat to desired cooking temperature. The amber pilot light will cycle on and off with the thermostat.
2. Allow skillet to preheat for approximately 15-30 minutes.
3. Once preheated, insert product in skillet and adjust thermostat to required cooking temperature.
4. If desired, once product has cooked, it can be held prior to serving at a lower temperature setting.
5. When cooking is completed, set thermostat and power switch to the 'OFF' position.
6. The best time to clean the skillet is immediately after use, once skillet has cooled down.





CLEANING INSTRUCTIONS



CARE AND CLEANING

Cooking equipment must be cleaned regularly to maintain its fast, efficient cooking performance and to ensure its continued safe, reliable operation. The best time to clean is shortly after each use (allow unit to cool to a safe temperature).

WARNINGS

- ⇒  Do not use detergents or cleansers that are chloride based or contain quaternary salt.
Chloride Cleaners
- ⇒  Do not use a metal bristle brush or scraper.
Wire Brush &
- ⇒  Steel wool should never be used for cleaning the stainless steel.
Steel Pads
- ⇒  Unit should never be cleaned with a high pressure spray hose.
High Pressure Spray Hose
- ⇒  Do not leave water sitting in unit when not in use.
Stagnant Water

CLEANING INSTRUCTIONS

1. Turn unit off.
2. Remove drain screen (if applicable). Thoroughly wash and rinse the screen either in a sink or a dishwasher.
3. Prepare a warm water and mild detergent solution in the unit.
4. Remove food soil using a nylon brush.
5. Loosen food which is stuck by allowing it to soak at a low temperature setting.
6. Drain unit.
7. Rinse interior thoroughly.
8. If the unit is equipped with a **Tangent Draw-Off Valve**, clean as follows:
 - a) Disassemble the draw-off valve first by turning the valve knob counter-clockwise, then turning the large hex nut counter-clockwise until the valve stem is free of the valve body.
 - b) In a sink, wash and rinse the inside of the valve body using a nylon brush.
 - c) Use a nylon brush to clean tangent draw-off tube.
 - d) Rinse with fresh water.
 - e) Reassemble the draw-off valve by reversing the procedure for disassembly. The valve's hex nut should be hand tight only.
9. Using mild soapy water and a damp sponge, wash the exterior, rinse, and dry.

NOTES

- ⇒ For more difficult cleaning applications one of the following can be used: alcohol, baking soda, vinegar, or a solution of ammonia in water.
- ⇒ Leave the cover off when the kettle is not in use.
- ⇒ For more detailed instructions refer to the Nafem Stainless Steel Equipment Care and Cleaning manual (supplied with unit).

STAINLESS STEEL EQUIPMENT CARE AND CLEANING

(Supplied courtesy of Nafem. For more information visit their web site at www.nafem.org)

Contrary to popular belief, stainless steels ARE susceptible to rusting.

Corrosion on metals is everywhere. It is recognized quickly on iron and steel as unsightly yellow/orange rust. Such metals are called "active" because they actively corrode in a natural environment when their atoms combine with oxygen to form rust.

Stainless steels are passive metals because they contain other metals, like chromium, nickel and manganese that stabilize the atoms. 400 series stainless steels are called ferritic, contain chromium, and are magnetic; 300 series stainless steels are called austenitic, contain chromium and nickel; and 200 series stainless, also austenitic, contains manganese, nitrogen and carbon. Austenitic types of stainless are not magnetic, and generally provide greater resistance to corrosion than ferritic types.

With 12-30 percent chromium, an invisible passive film covers the steel's surface acting as a shield against corrosion. As long as the film is intact and not broken or contaminated, the metal is passive and stain-less. If the passive film of stainless steel has been broken, equipment starts to corrode. At its end, it rusts.

Enemies of Stainless Steel

There are three basic things which can break down stainless steel's passivity layer and allow corrosion to occur.

1. Mechanical abrasion
2. Deposits and water
3. Chlorides

Mechanical abrasion means those things that will scratch a steel surface. Steel pads, wire brushes and scrapers are prime examples.

Water comes out of the faucet in varying degrees of hardness. Depending on what part of the country you live in, you may have hard or soft water. Hard water may leave spots, and when heated leave deposits behind that if left to sit, will break down the passive layer and rust stainless steel. Other deposits from food preparation and service must be properly removed.

Chlorides are found nearly everywhere. They are in water, food and table salt. One of the worst chloride perpetrators can come from household and industrial cleaners.

So what does all this mean? Don't Despair!

Here are a few steps that can help prevent stainless steel rust.

1. Use the proper tools.

When cleaning stainless steel products, use non-abrasive tools. Soft cloths and plastic scouring pads will not harm steel's passive layer. Stainless steel pads also can be used but the scrubbing motion must be in the direction of the manufacturers' polishing marks.

2. Clean with the polish lines.

Some stainless steel comes with visible polishing lines or "grain." When visible lines are present, always scrub in a motion parallel to the lines. When the grain cannot be seen, play it safe and use a soft cloth or plastic scouring pad.

3. Use alkaline, alkaline chlorinated or non-chloride containing cleaners.

While many traditional cleaners are loaded with chlorides, the industry is providing an ever-increasing choice of non-chloride cleaners. If you are not sure of chloride content in the cleaner used, contact your cleaner supplier. If your present cleaner contains chlorides, ask your supplier if they have an alternative. Avoid cleaners containing quaternary salts; it also can attack stainless steel and cause pitting and rusting.

4. Treat your water.

Though this is not always practical, softening hard water can do much to reduce deposits. There are certain filters that can be installed to remove distasteful and corrosive elements. To insure proper water treatment, call a treatment specialist.

5. Keep your food equipment clean.

Use alkaline, alkaline chlorinated or non-chloride cleaners at recommended strength. Clean frequently to avoid build-up of hard, stubborn stains. If you boil water in stainless steel equipment, remember the single most likely cause of damage is chlorides in the water. Heating cleaners that contain chlorides have a similar effect.

6. Rinse, rinse, rinse.

If chlorinated cleaners are used, rinse and wipe equipment and supplies dry immediately. The sooner you wipe off standing water, especially when it contains cleaning agents, the better. After wiping equipment down, allow it to air dry; oxygen helps maintain the stainless steel's passivity film.

7. Never use hydrochloric acid (muriatic acid) on stainless steel.

8. Regularly restore/passivate stainless steel.

Recommended cleaners for specific situations

Job	Cleaning Agent	Comments
Routine cleaning	Soap, ammonia, detergent, Medallion	Apply with cloth or sponge
Fingerprints & smears	Arcal 20, Lac-O-Nu Ecoshine	Provides barrier film
Stubborn stains & discoloration	Cameo, Talc, Zud, First Impression	Rub in direction of polish lines
Grease & fatty acids, blood, burnt-on-foods	Easy-off, De-Grease It Oven Aid	Excellent removal on all finishes
Grease & oil	Any good commercial detergent	Apply with sponge or cloth
Restoration/Passivation	Benefit, Super Sheen	

Review

1. Stainless steels rust when passivity (film-shield) breaks down as a result of scrapes, scratches, deposits and chlorides.
2. Stainless steel rust starts with pits and cracks.
3. Use the proper tools. Do not use steel pads, wire brushes or scrapers to clean stainless steel.
4. Use non-chlorinated cleaners at recommended concentrations. Use only chloride-free cleaners.
5. Soften your water. Use filters and softeners whenever possible.
6. Wipe off cleaning agent(s) and standing water as soon as possible. Prolonged contact causes eventual problems.

To learn more about chloride-stress corrosion and how to prevent it, contact the equipment manufacturer or cleaning materials supplier.

Developed by Packer Engineering, Naperville, Ill., an independent testing laboratory.

HYDRAULIC JACK ASSEMBLIES

Hydraulic Jack Assembly KE000772

For units built prior to February 2005
(replaces old Jack #s SK2381000 & SK00403)

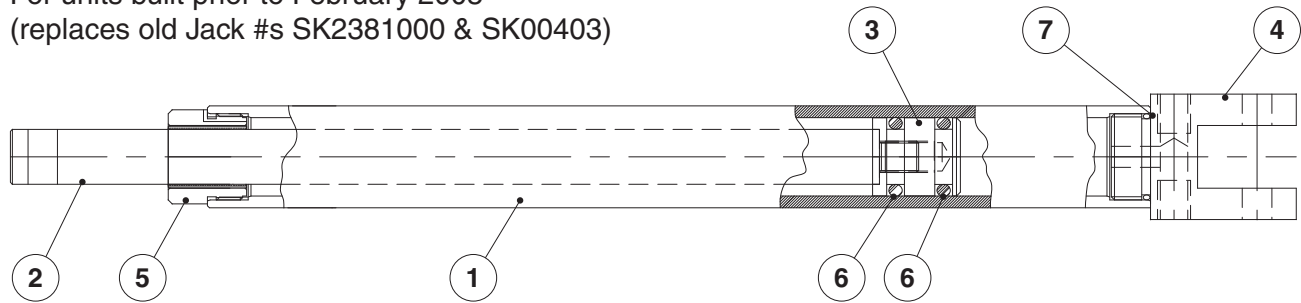

Hydraulic Jack Assembly KE000523

For units built after February 2005

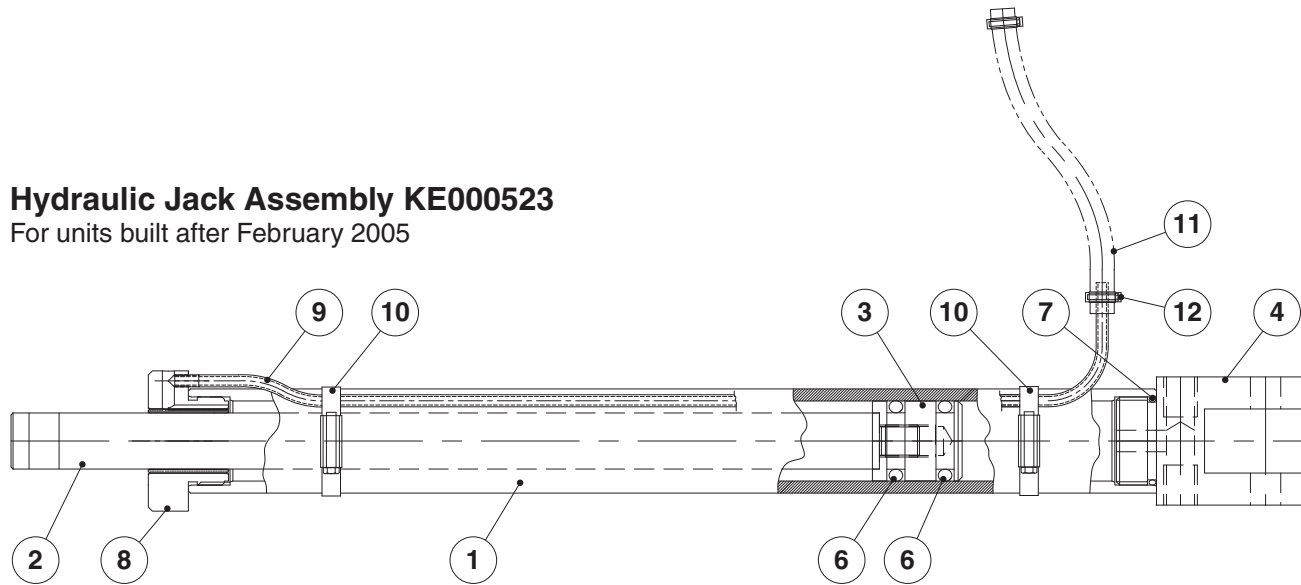

ITEM NO.	PART NO.	DESCRIPTION	QTY.
1	KE600526	HYDRAULIC CYLINDER	1
2	KE600527	PUSH ROD	1
3	KE600528	HYDRAULIC PISTON	1
4	KE600529	FORK, HYDRAULIC JACK	1
5	KE000771	GUIDE BUSHING ASSEMBLY	1
6	FA05002-41	O RING, 7/8 I.D. X 1 1/4 O.D.	2
7	FA05002-40	O RING, 1 3/16 I.D. X 1 3/8 O.D.	1
8	KE000525	GUIDE BUSHING ASSEMBLY	1
9	KE600667	DRAIN TUBE	1
10	F105220-4	HOSE CLAMP	2
11	KE600668	DRAIN HOSE	1
12	F105220-1	HOSE CLAMP	2

HYDRAULIC JACK ASSEMBLIES - HAND TILT

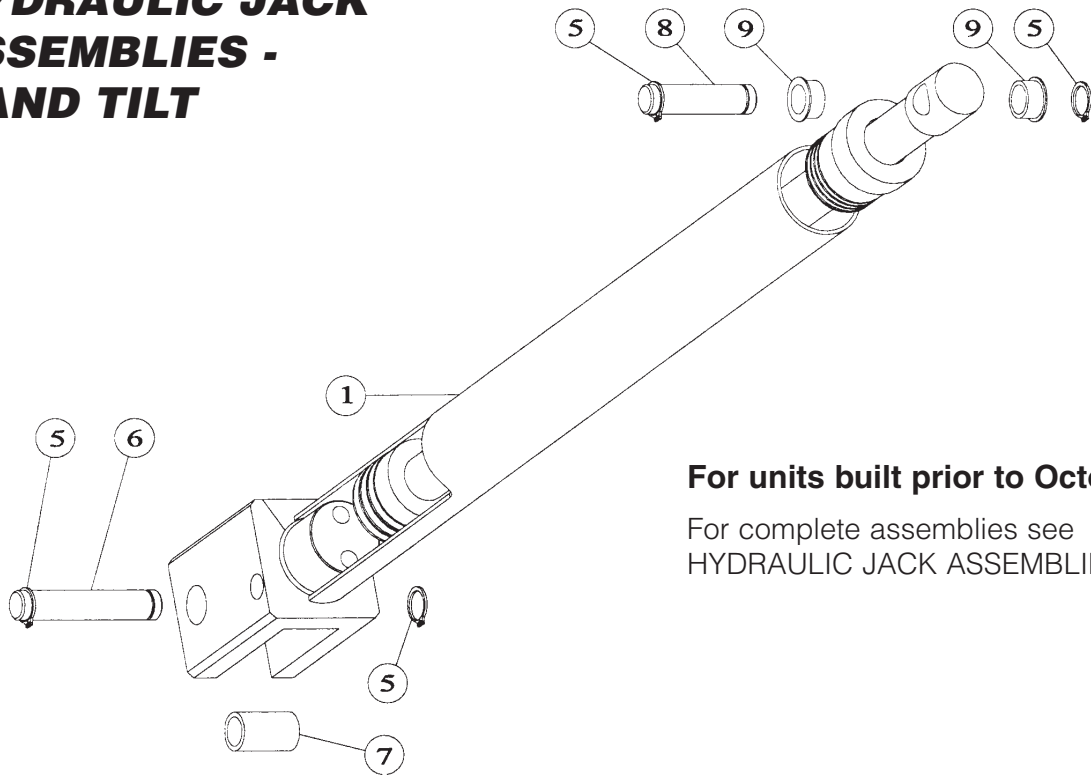

For units built prior to October 2001

For complete assemblies see
HYDRAULIC JACK ASSEMBLIES.

ITEM NO.	PART NO.	DESCRIPTION	QTY.
1	2381000	HYDRAULIC JACK ASSEMBLY (NO LONGER AVAILABLE, USE KE000772)	1
5	FA95007-7	RETAINING RING	4
6	2376503	ACTUATOR PIN (FRONT)	1
7	2357500	SLEEVE BEARING	1
8	2376504	ACTUATOR PIN (REAR)	1
9	FA30505-3	WASHER	2

ACTUATOR ASSEMBLY - POWER TILT

(used prior to January, 2000)

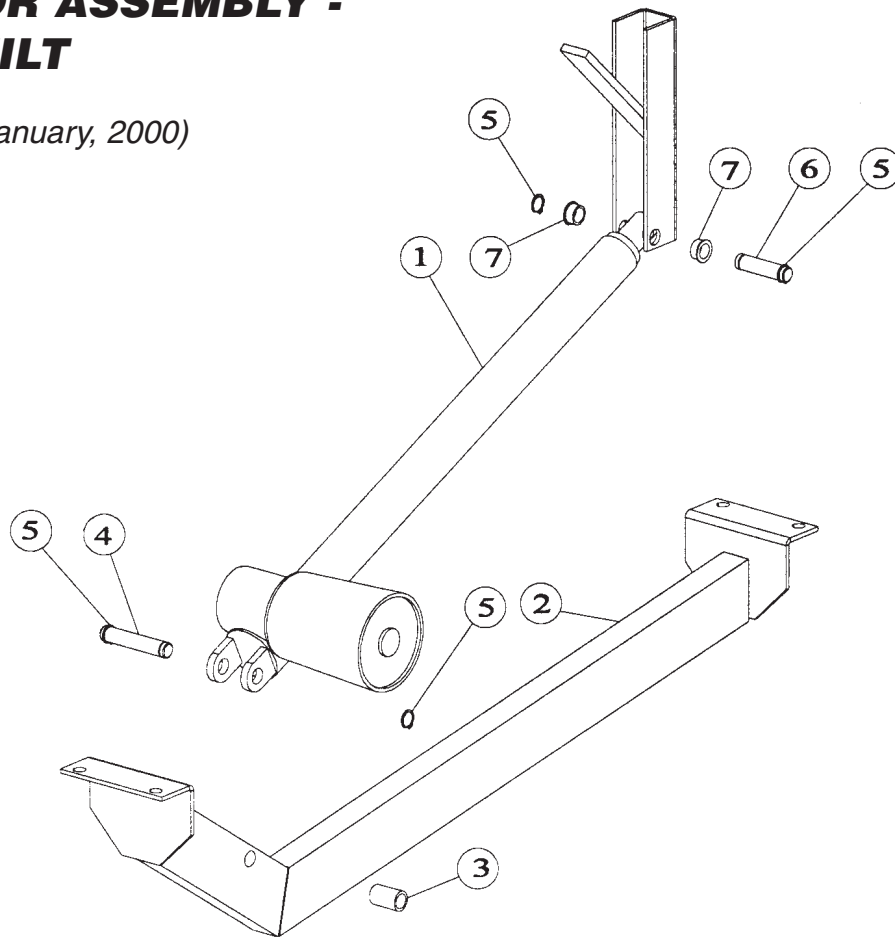

ITEM NO.	PART NO.	DESCRIPTION	QTY.
1.	SK2346101	ACTUATOR	1
2.	SK2337499	ACTUATOR MOUNTING BRACKET ASSY.	1
3.	SK2357500	SLEAVE BEARING	1
4.	SK2376503	ACTUATOR PIN, FRONT	1
5.	FA95007-7	RETAINING RING	1
6.	SK2376504	ACTUATOR PIN, REAR	1
7.		FLANGE BEARING	2

obsolete no
replacement (no
longer used)

ACTUATOR ASSEMBLY - POWER TILT

(used after January, 2000)

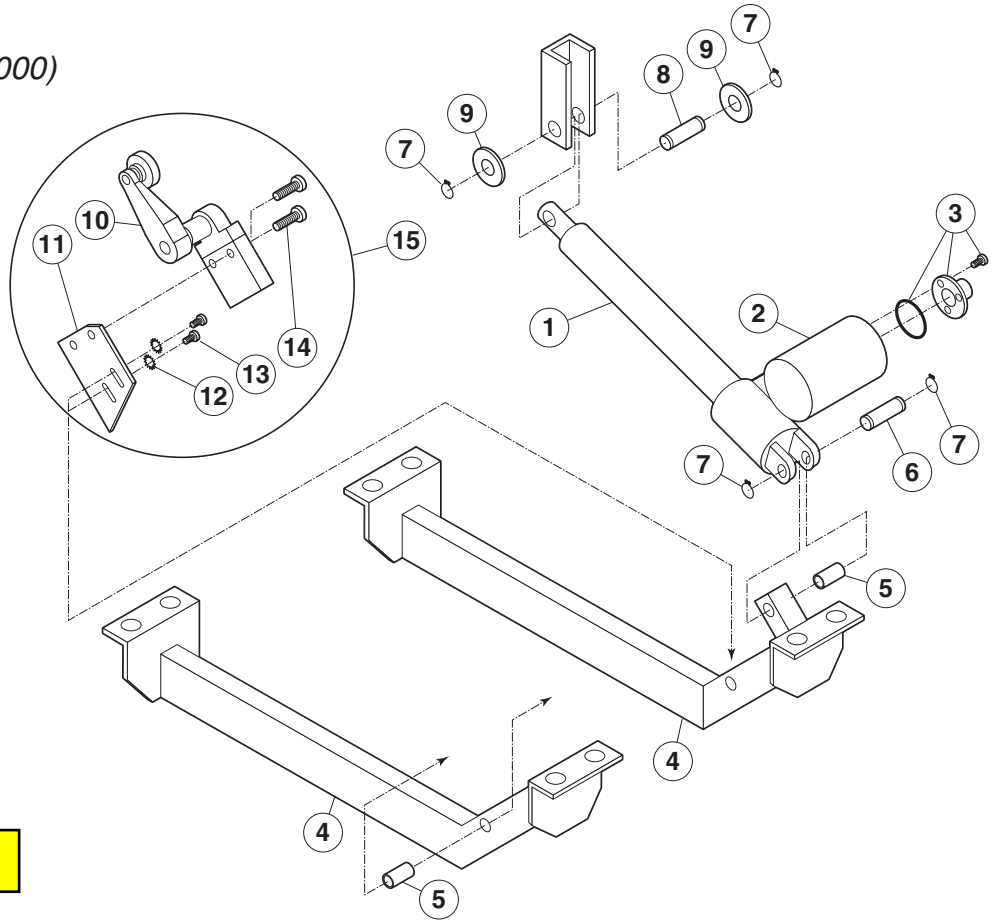

Polyswitch
SK2533199

ITEM NO.	PART NO.	DESCRIPTION	QTY.
1.	SK2346101	ACTUATOR ASSY., WITH MANUAL OVERRIDE, COMPLETE WITH ITEMS 2 & 3	1
	KE003242		1
2.	SK2346100-1	MOTOR	1
	SK2346101-1	MOTOR, WITH MANUAL OVERRIDE	1
3.	KE603205	COVER	1
	FA11091	SCREWS, SS, 8-32 X 3/8	3
	FA05002-54	O-RING	1
4.	SK2337499	MOUNTING BRACKET, WITHOUT TANGENT DRAW-OFF VALVE ON PAN	1
	SK00352	MOUNTING BRACKET, WITH TANGENT DRAW-OFF VALVE ON PAN	1
5.	SK2357500	SLEEVE BEARING	1
6.	SK2376503	ACTUATOR PIN, LONG	1
7.	FA95007-7	RETAINING RING	4
8.	SK2376504	ACTUATOR PIN, SHORT	1
9.	FA30505-3	WASHER	2
10.	KE601979	LIMIT SWITCH	1
11.	KE601960	BRACKET, LIMIT SWITCH, WITHOUT TANGENT DRAW-OFF VALVE ON PAN	1
	KE602198	BRACKET, LIMIT SWITCH, WITH TANGENT DRAW-OFF VALVE ON PAN	1
12.	FA32005	LOCKWASHER, #8	2
13.	F10	SCREW, #8-32X3/8	2
14.	F12	SCREW, #10-24X1/2	2
15.	KE002226	KIT FOR UNITS BUILT PRIOR TO MARCH 2006	1

HYDRAULIC TILT ASSEMBLY

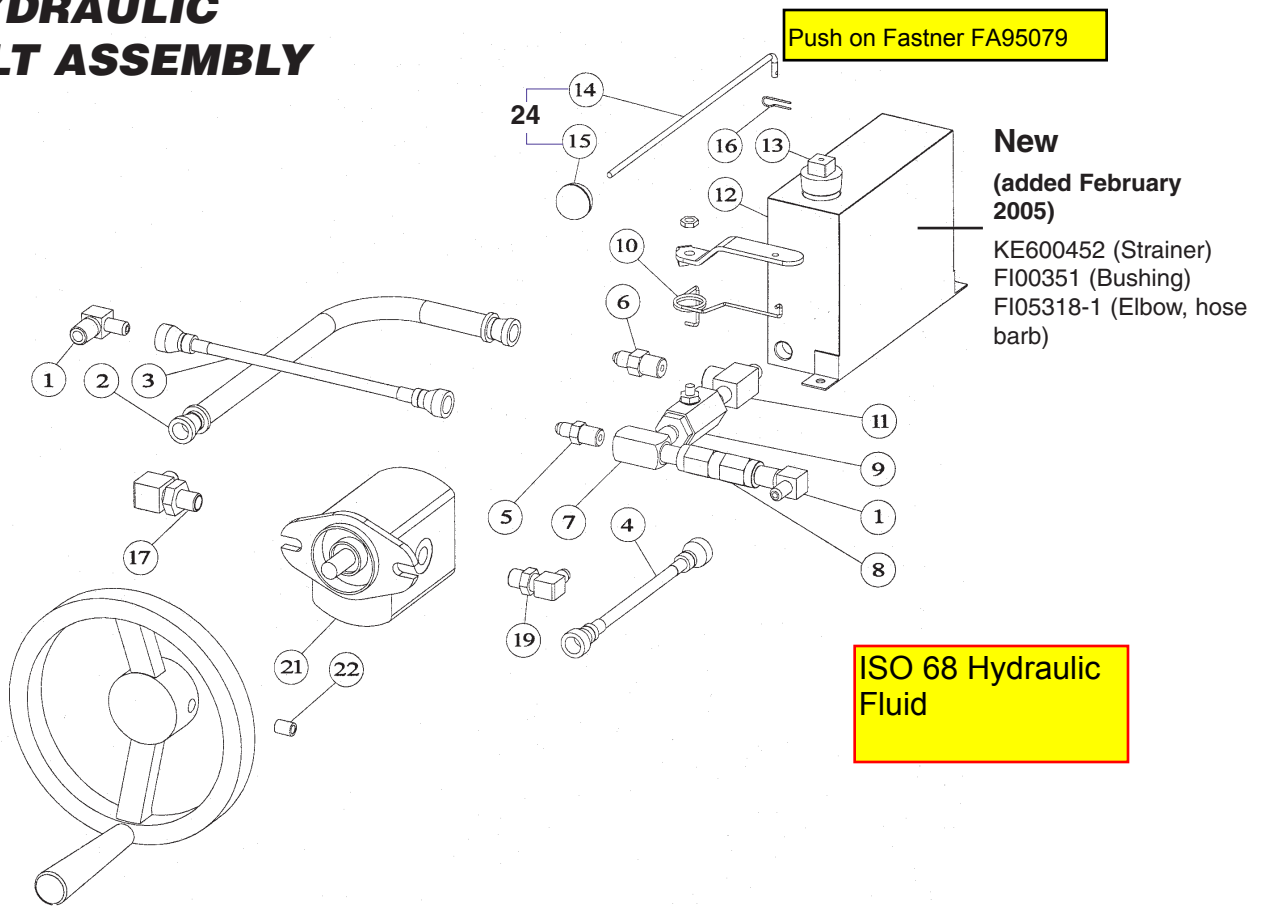

ITEM NO.	PART NO.	DESCRIPTION	QTY.
1	2379100	HYDRAULIC ADAPTOR	2
2	2379600	HYDRAULIC HOSE ASSY	1
3	2379501	HYDRAULIC HOSE ASSY	1
4	2379500	HYDRAULIC HOSE ASSY, 8" LONG	1
5	2379000	HYDRAULIC ADAPTOR	1
6	2379001	HYDRAULIC ADAPTOR	1
7	2378901	TEE F/M/M	1
8	2379400	CHECK VALVE	1
9	2379301	BALL VALVE C/W HANDLE AND NUT	1
10	2382700	VALVE RETURN SPRING	1
11	2378900	TEE M/F/M	1
12	2375699	OIL TANK ASSY	1
13	2250700	PLUG (DRILLED)	1
14	2376200	LINK ROD	1
15	078279-1	BALL KNOB	1
16	FA95079	PUSH-ON FASTENER	1
17	FI05059	1/2" TO 3/8"	1
19	2379200	ELBOW WITH O-RING 3/8 TO 1/4"	1
21		HYDRAULIC PUMP	
	SK2378802	USED PRIOR TO JANUARY 2002	1
	SK2378801	USED BETWEEN JANUARY 2002 & FEBRUARY 2005	1
	SK2378802	USED AFTER FEBRUARY 2005	1
22	KE00508-1	HANDWHEEL ASSY	1
23		1/4-28 x 3/8" part number FA19500-5	1

24 SE00128 Link Rod Kit

CONTROL PANEL

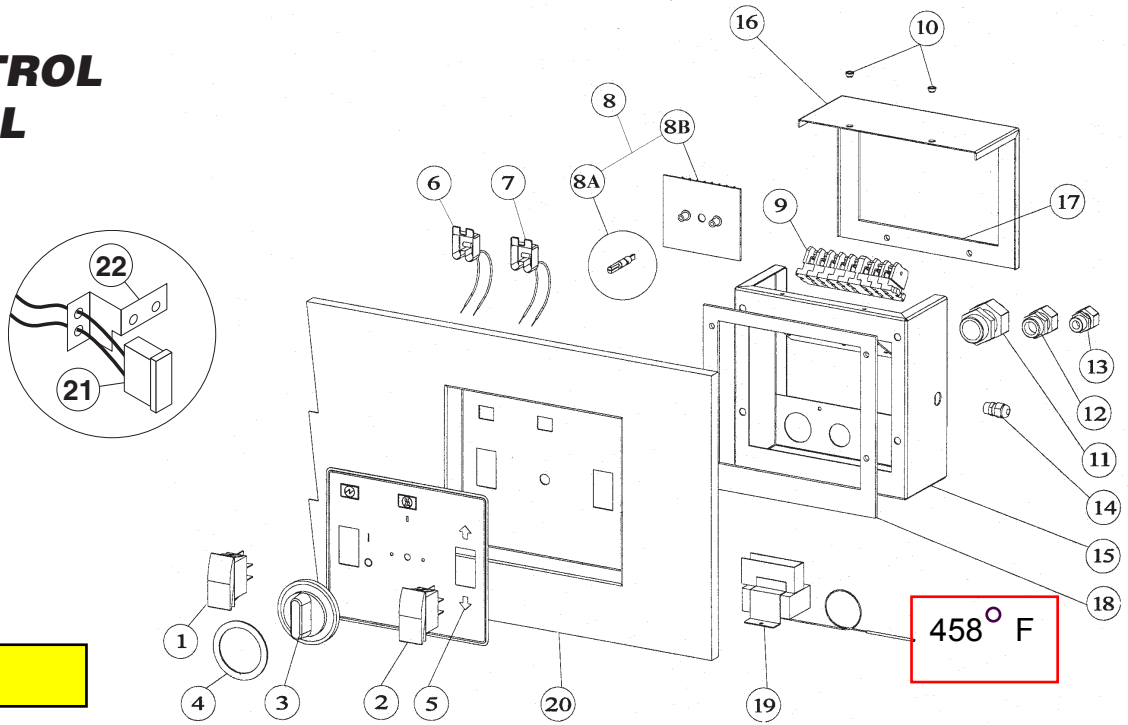

Polyswitch
SK2533199

ITEM NO.	PART NO.	DESCRIPTION	QTY.
1	2474101	POWER SWITCH (240V, USED AFTER FEBRUARY 2001)	1
	2474100	POWER SWITCH (USED AFTER FEBRUARY 2001)	1
	2343500	POWER SWITCH (USED PRIOR TO FEBRUARY 2001)	1
	2343502	TILT SWITCH (POWER TILT ONLY, USED AFTER FEBRUARY 2001)	1
2	2343501	TILT SWITCH (POWER TILT ONLY, USED PRIOR TO FEBRUARY 2001)	1
	SK2533199	FUSE, POLYSWITCH ASSY.	1
3	2138700	DIAL KNOB	1
4	2360701	DIAL INSERT °C	1
	2360700	DIAL INSERT °F . 100-425 Degrees	1
5	KE95586-1	LABEL, CLEVELAND, MANUAL TILT	1
	KE95586-2	LABEL, CLEVELAND, POWER TILT	1
	KE95586-3	LABEL, GARLAND, MANUAL TILT	1
	KE95586-4	LABEL, GARLAND, POWER TILT	1
6	2356100	INDICATOR LIGHT, GREEN, USED PRIOR TO FEB. 2001 (ORDER SERVICE PART # SE00121)	1
7	2356102	INDICATOR LIGHT, AMBER, USED PRIOR TO FEB. 2001 (ORDER SERVICE PART # SE00131)	1
8	SE00119	ELECTRONIC THERMOSTAT KIT (INCLUDES 8A & 8B)	1
9	SK50872-1	TERMINAL BLOCK	18
	SK50872-2	TERMINAL END	3
10	F33	SEALER WASHER	4
11	2147403	LIQUID-TIGHT FITTING 5/8"	1
12	2147402	LIQUID-TIGHT FITTING 3/8"	1
13	2147401	LIQUID-TIGHT FITTING 5/16" (POWER TILT ONLY)	1
14	2147400	LIQUID-TIGHT FITTING 3/16"	1
15	2352898	CONTROL BOX ASSY.	1
16	2353100	CONTROL BOX COVER	1
17	2383200	CONTROL COVER GASKET	1
18	2357900	NEOPRENE GASKET	1
19	KE55069-7	HIGH LIMIT	1
20	SK00383-1	CONTROL PANEL, POWER TILT, 40-TR	1
	SK00383-2	CONTROL PANEL, POWER TILT, 30-TR	1
	SK00383-3	CONTROL PANEL, MANUAL TILT, 40-TR	1
	SK00383-4	CONTROL PANEL, MANUAL TILT, 30-TR	1
21	SK50905-1	INDICATOR LIGHT, USED AFTER FEB, 2001 (GAS MODELS)	1
	SK50905-2	INDICATOR LIGHT, USED AFTER FEB, 2001 (ELECTRIC MODELS)	1
22	SK50903	BRACKET, USED AFTER FEB, 2001	1

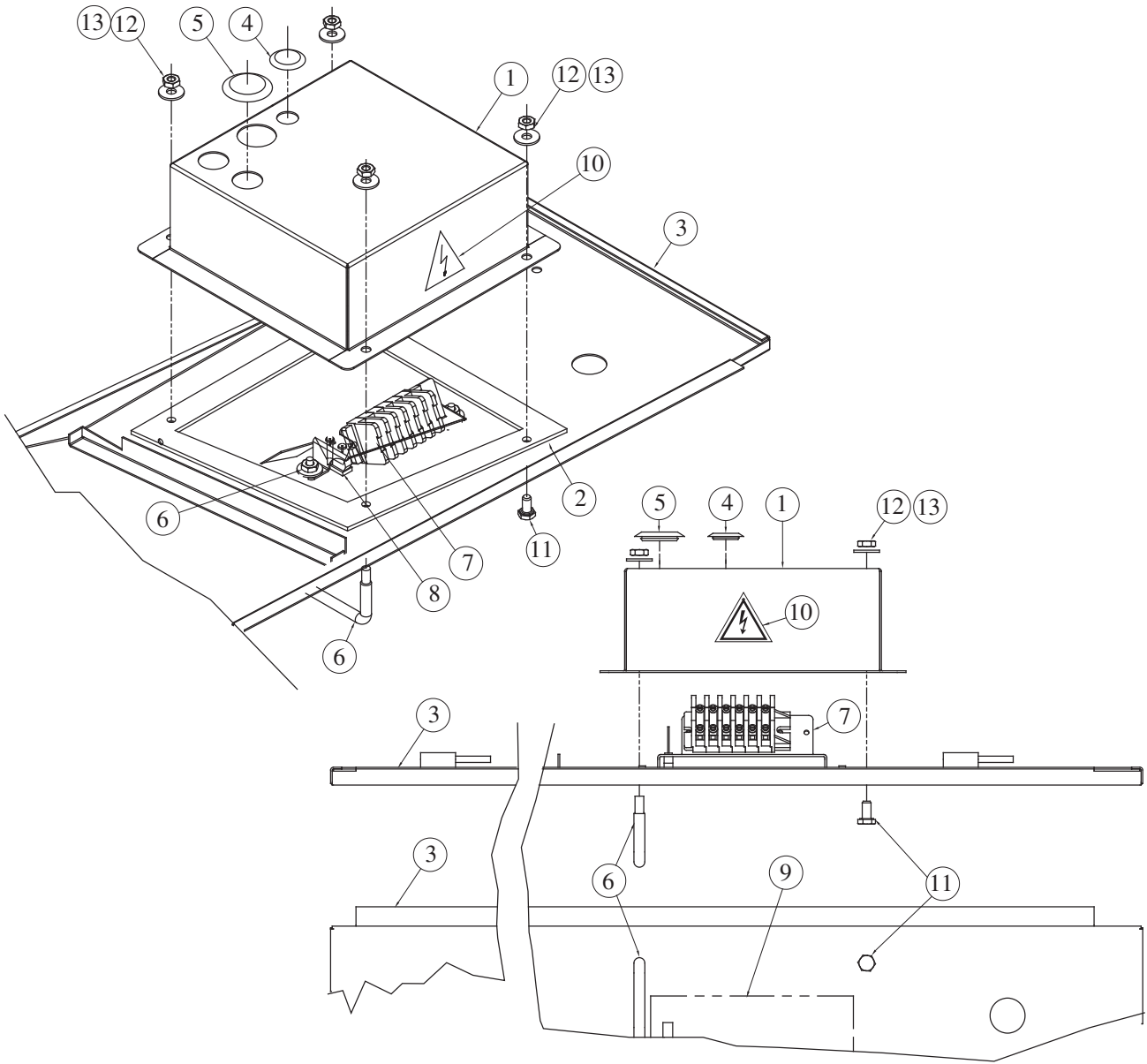

KE003742

KE003742-1 PANEL ASSEMBLY SGL-30-TR			
ITEM	PART NUMBER	DESCRIPTION	QTY.
1	KE603728	COVER; CONTROL SWITCHES	1
2	KE603729	GASKET	1
3	SK00383-4	CONTROL PANEL ASS'Y 30 GAL	1
4	KE54907-3	PLUG BUTTON (5/8 HOLE)	1
5	KE54907-6	PLUG BUTTON (7/8 HOLE)	1
6	KE601005	SWITCH GUARD	1
7	KE603726	TERMINAL BLOOCK BRACKET	1
8	SK50905-1	28V INDICATOR CLEAR LIGHT	1
9	KE95586-1	LABEL; TR SKILLETS	1
10	KE95497	LABEL; RISK OF EL. SHOCK	1
11	FA11260	HEX BOLT S.S. 1/4-20 X 1	2
12	FA30505-1	FLAT WASHER S.S 1/4	4
13	FA21008	HEX NUT S.S 1/4	4
14	FA20504-3	LOCK NUT #10	2

KE003742-2 PANEL ASSEMBLY SGL-40-TR			
ITEM	PART NUMBER	DESCRIPTION	QTY.
1	KE603728	COVER; CONTROL SWITCHES	1
2	KE603729	GASKET	1
3	SK00383-3	CONTROL PANEL ASS'Y 40 GAL	1
4	KE54907-3	PLUG BUTTON (5/8 HOLE)	1
5	KE54907-6	PLUG BUTTON (7/8 HOLE)	1
6	KE601005	SWITCH GUARD	1
7	KE603726	TERMINAL BLOOCK BRACKET	1
8	SK50905-1	28V INDICATOR CLEAR LIGHT	1
9	KE95586-1	LABEL; TR SKILLETS	1
10	KE95497	LABEL; RISK OF EL. SHOCK	1
11	FA11260	HEX BOLT S.S. 1/4-20 X 1	2
12	FA30505-1	FLAT WASHER S.S 1/4	4
13	FA21008	HEX NUT S.S 1/4	4
14	FA20504-3	LOCK NUT #10	2

SHAFT ASSEMBLY

1

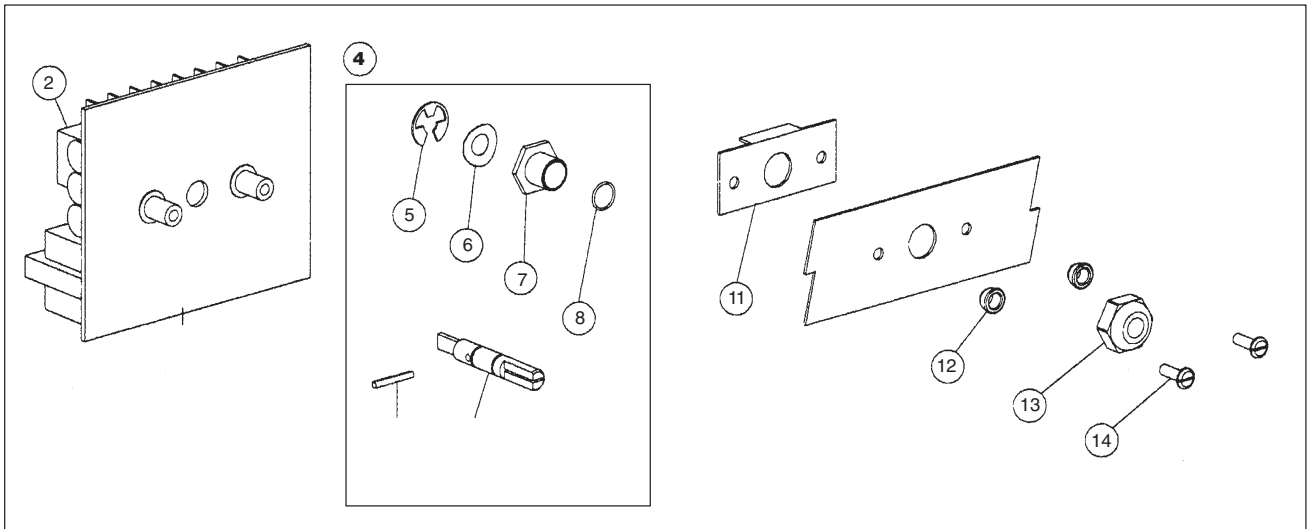

ITEM NO.	PART NO.	DESCRIPTION	QTY.
1.	SE00119	THERMOSTAT BOARD ASSEMBLY (INCLUDES 2 - 14)	1

ELECTRICAL BOX

Component Box Cover 2343900

Igniton cable SE00111

KE002226
Replacement Kit

KE003668 for units
prior to 4/10
KE603774-1 for units
after 4/10

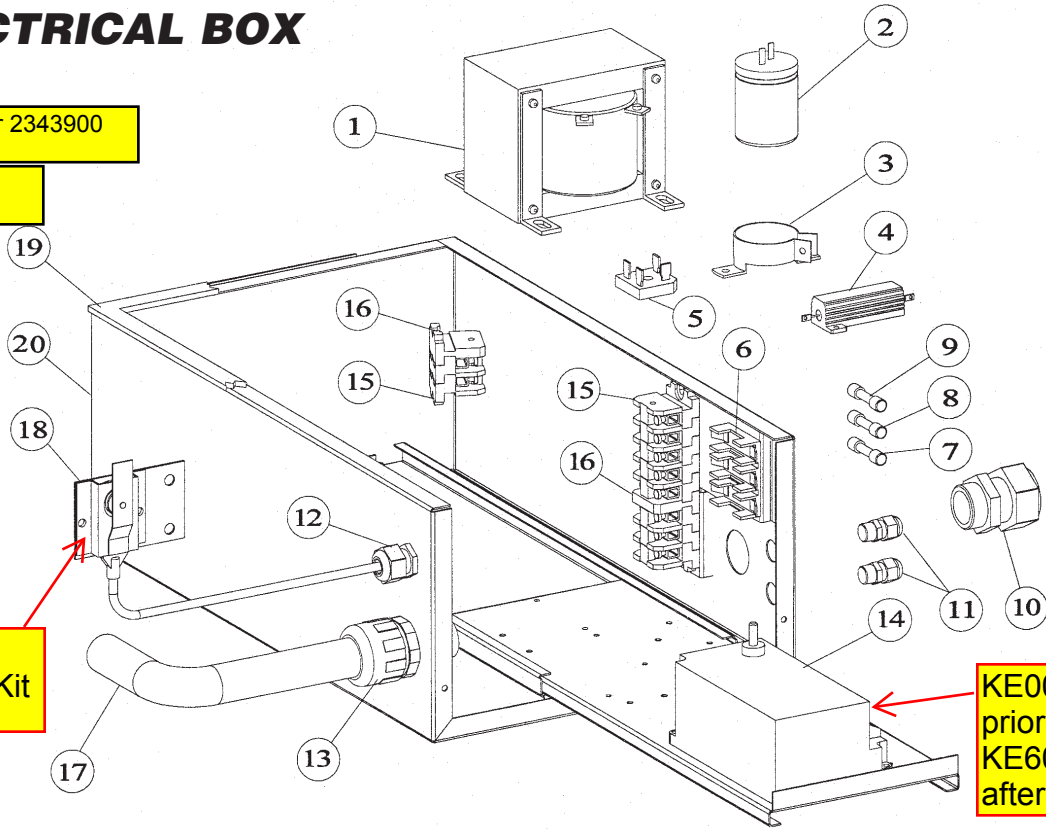

ITEM NO.	PART NO.	DESCRIPTION	QTY.
1	KE53838-32	TRANSFORMER - POWER TILT - 110-120V/60	1
	KE53838-31	TRANSFORMER - POWER TILT - 208-240/60	1
	KE53838-30	TRANSFORMER - POWER TILT - 208-240/50	1
	KE53838-25	TRANSFORMER - HAND TILT - 110-120/60	1
	KE53838-18	TRANSFORMER - HAND TILT - 208-240	1
2	1427305	CAPACITOR	1
3	2282100	CAPICITOR CLAMP	1
4	1426600	RESISTOR	1
5	KE50581	RECTIFIER, POWER TILT ONLY	1
6	2320702	FUSE HOLDER	1
7	KE52936-7	FUSE 2.5A MDL 115V POWER TILT	1
	KE52936-10	FUSE 1.5A MDL 208/240V POWER TILT	1
	KE52936-13	FUSE 1A AGC 115V HAND TILT	1
	KE52936-11	FUSE .5A AGC 208/240V HAND TILT	1
8	KE52936-9	FUSE 15A MDA POWER TILT ONLY	1
9	KE52936-8	FUSE 1.25A AGC	1
10	2147403	LIQUID-TIGHT FITTING	1
11	2147400	LIQUID-TIGHT FITTING	2
12	2147401	LIQUID-TIGHT FITTING	1
13	2361500	LIQUID-TIGHT FITTING	1
14	2329100	IGNITION MODULE	1
15	SK50872-1	TERMINAL BLOCK - SECTION	18
16	SK50872-2	TERMINAL END	1
17	2361700	LIQUID-TIGHT CONDUIT	1
18	2348100	SEALED SWITCH	1
19	2383300	COVER GASKET	1
20	2343699	SERVICE BOX ASSY.	1

Direct Spark Ignition

24VAC & 120VAC

DXM Series

MAXLITER

IGNITION CONTROL

FEATURES:

- Diagnostic LED Indicator light
- Remote or Local Flame Sensing
- Natural and LP Gas Equipment
- Multiple Tries For Ignition
- Potted or with Integral Stand-Offs
- Custom Pre-Purge & Inter-Purge Timings
- Automatic One Hour Reset

APPLICATIONS:

- Infrared Radiant Heaters
- Commercial Cooking Equipment
- Gas Fired Furnaces, Fire Places and Gas Boilers
- Commercial Water Heaters and Dryers

DESCRIPTION

The model DXM above is a 24 or 120VAC Direct Spark ignition control. The microprocessor circuit design provides precise, repeatable timing and operating sequences. The on-board diagnostics with LED output provides assistance with troubleshooting to ensure a safe and efficient operation.

Full featured design makes it the right choice for any gas fired direct spark appliance and works with both natural and LP gas.

APPROVALS

Software conforms to UL 1998 requirements
Designed to ANSI Z21.20 Standards

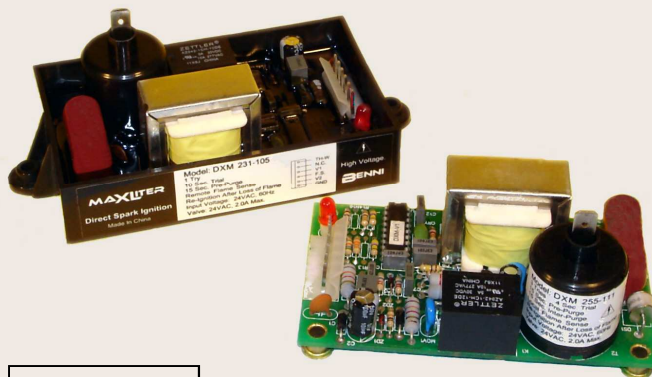

Model DXM

Specifications

INPUT VOLTAGE	- 18-30VAC 50/60 Hz (Class 2 Transformer) or - 102-138VAC 50/60 Hz
CURRENT DRAW MAIN VALVE	2.0A @ 24VAC or 120VAC
INPUT CURRENT DRAIN	300 mA @ 24VAC, 350 mA @120VAC
VALVE CONTACT RATING	2.0A @ 24VAC, 1.5A@ 120VAC
OPERATING TEMPERATURE	-40F to 175F, -40C to +80C
TYPES OF GASES	Natural, LP, or Manufactured
FLAME SENSITIVITY	0.7uA Minimum
SPARK RATE	50/60 Hz (Line Frequency)
FLAME FAILURE RESPONSE	0.8 Seconds Maximum
SIZE (L x W x H)	4.00 x 2.30 x 1.50 inches
ENCLOSURE	Potted or Integral Stand Offs
MOISTURE RESISTANCE	CONFORMAL COATED OR POTTED TO 95% R.H. AVOID DIRECT EXPOSURE TO WATER
WEIGHT	

ON BOARD DIAGNOSTICS

LOCKOUT MODE	LED INDICATION
Ignition Failure	2 Flashes
Exceed Flame Lost	3 Flashes
MCU Failure or Flame Exists	4 Flashes

Main Offices/Warehouse:



3267 Grapevine Street
Mira Loma, CA 91752
TEL: 951-360-5537
FAX: 951-360-5329

Web: www.bennitech.com

Ordering Information

DXM	X	X	X	X	-	X	X	X		DESCRIPTION
										RESET METHODS AND ENCLOSURE
										2 = POWER OFF RESET - POTTED
										3 = AUTOMATIC RESET - POTTED
										4 = POWER OFF RESET - INTEGRAL STAND OFFS WITH NO COVER
										5 = AUTOMATIC RESET - INTEGRAL STAND OFFS WITH NO COVER
										FLAME SENSING METHOD
										R = REMOTE SENSE (DUAL ROD)
										L = LOCAL SENSE (SINGLE ROD)
										TRIAL FOR IGNITION
										1 = 4 SECONDS
										2 = 7 SECONDS
										5 = 10 SECONDS
										INTER-PURGE
										0 = NONE (Single Try Models Only)
										1 = 15 SECONDS
										2 = 30 SECONDS
										PRE-PURGE
										0 = NONE
										1 = 15 SECONDS
										2 = 30 SECONDS
										TRIES FOR IGNITION
										1 = SINGLE TRY ONE HOUR AUTO RESET
										2 = THREE TRIES ONE HOUR AUTO RESET
										3 = SINGLE TRY NO ONE HOUR RESET
										4 = THREE TRIES NO ONE HOUR RESET
										INPUT VOLTAGE
										2 = 24VAC
										3 = 120VAC
										9 = CUSTOM SPECIAL OEM CONFIGURATION
										DXM = DIRECT SPARK IGNITION CONTROL MaxLiter Series

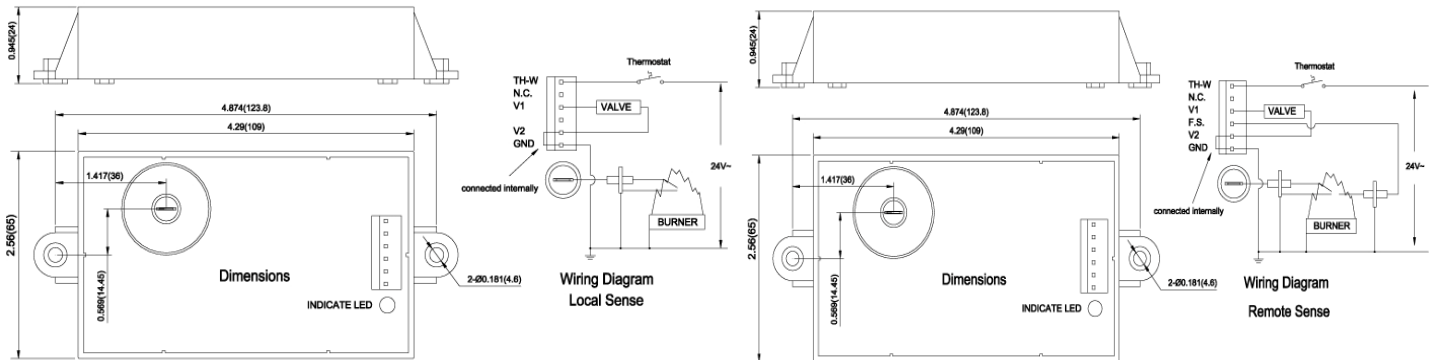

DISCONNECT THE POWER SUPPLY BEFORE MAKING WIRING CONNECTIONS TO PREVENT ELECTRICAL SHOCK OR EQUIPMENT DAMAGE.

EXPLOSION HAZARD. CAN CAUSE INJURY OR EQUIPMENT DAMAGE.

Only trained professional gas appliance service technicians should install and check out this control.

PLATE ASSEMBLY

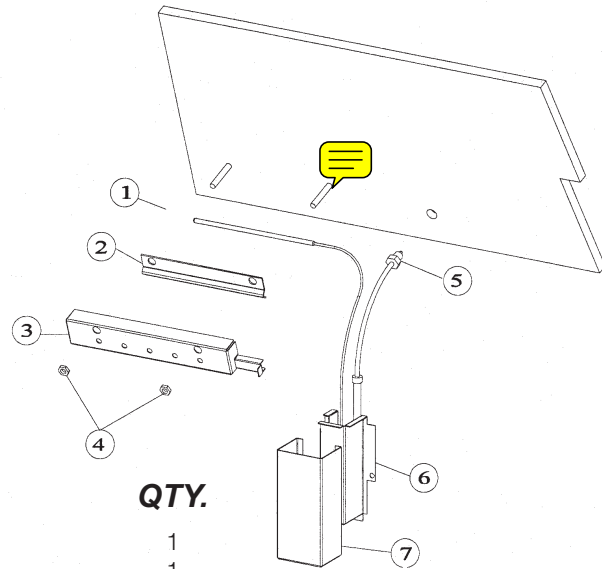

ITEM NO.	PART NO.	DESCRIPTION	QTY.
1	KE55069-7	HI-LIMIT	1
2	2353900	BULB CLAMP	1
3	2354099	BULB SHIELD ASSY	1
4	F95	NUT	1
5	2345100	RTD SENSOR	1
6	2344900	SHIELD LINER	1
7	2345000	SHIELD	1

PAN HINGE

13 14

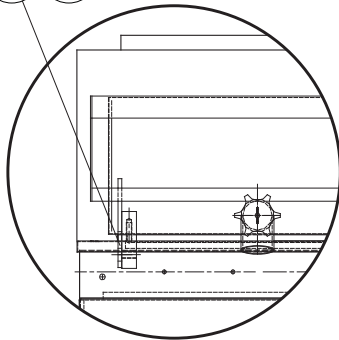

For units with TD Valve

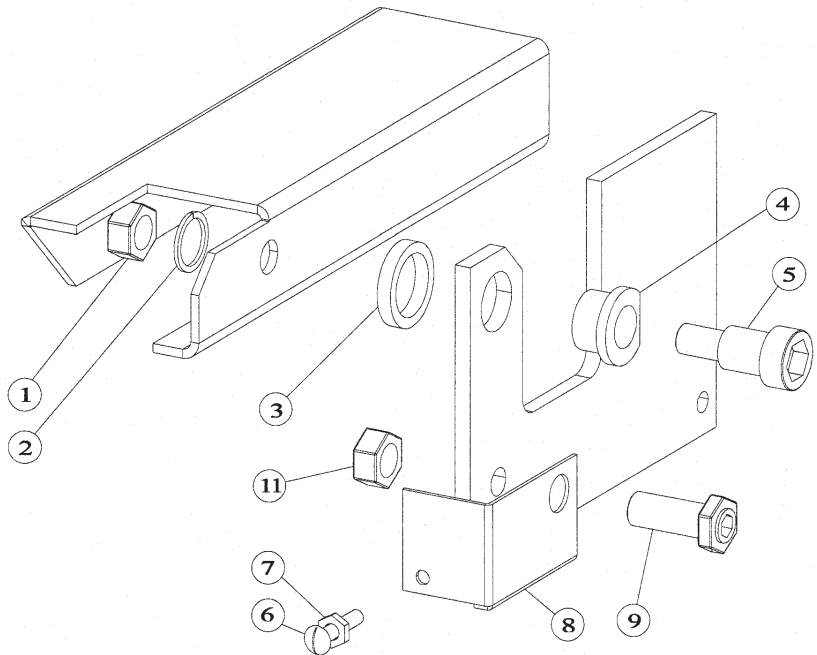

ITEM NO.	PART NO.	DESCRIPTION	QTY.
1	FA21053	LOCK NUT 1/2-13 S.S.	2
2	FA30505-3	LOCK WASHER 1/2-13 S.S.	2
3	078248-1	SPACER	2
4	G02925-2	BUSHING	2
5	FA15015	BOLT 1/2-13 X 3/4"	2
6	FA10245	TRUSS HEAD SCREW 8-32 X 1 S.S.	1
7	FA21004	HEX NUT 8-32 S.S.	1
8	2354199	STRIKER PLATE ASSY	1
9	FA11224	HEX BOLT, 5/16-18 X 1" LONG	1
11	FA21024	HEX NUT 1/2-13 S.S.	1
13	FA15019-2	SHOULDER BOLT, 1/2-13 (303)	2
14	SK50813	BEARING HINGE	2

SPRING ASSEMBLY

To replace bellcrank hook, flue insert must be removed.

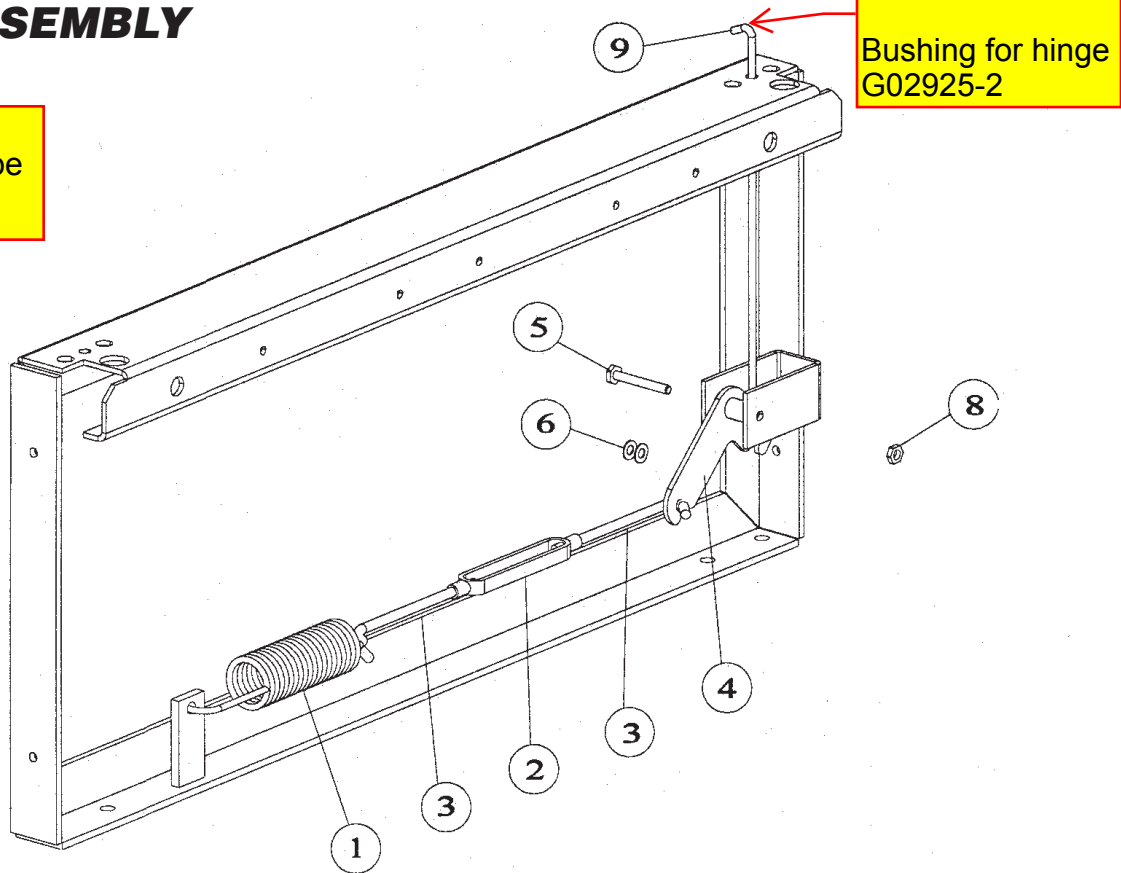

Shoulder bolt
F909
Bushing for hinge
G02925-2

ITEM NO.	PART NO.	DESCRIPTION	QTY.
1	2452300	SPRING2
2	2381700	TURNBUCKLE BODY2
3	2374900	CONNECTING ROD R/H THREAD2
	2374901	CONNECTING ROD L/H THREAD2
4	2529499	BELL CRANK ASSY2
5	1082200	BOLT, 9/16-18 X 1-5/16 SHOULDER2
6	F112	FLAT WASHER 3/8" I.D.4
8	FA20500	NUT, 9/16-18, S.S.2
9	2372400	BELL CRANK HOOK2

Lid Hinge Assembly

KE003605 (BACKGUARD ASSEMBLY) for 40-TR
KE003605-1 (BACKGUARD ASSEMBLY) for 30-TR

F909 Shoulder Bolt

sk2357300 Bushing

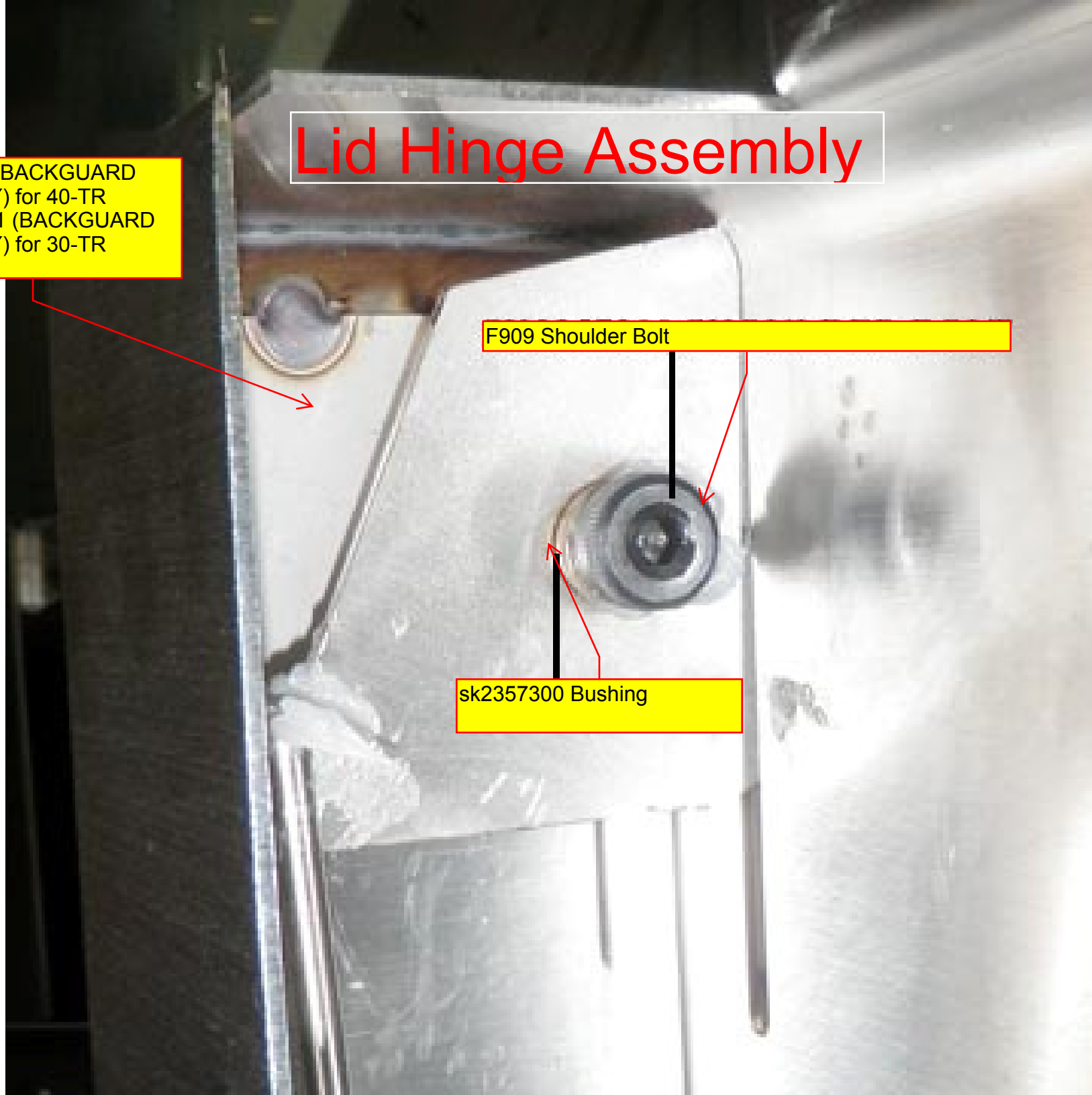

BURNER BOX ASSEMBLY

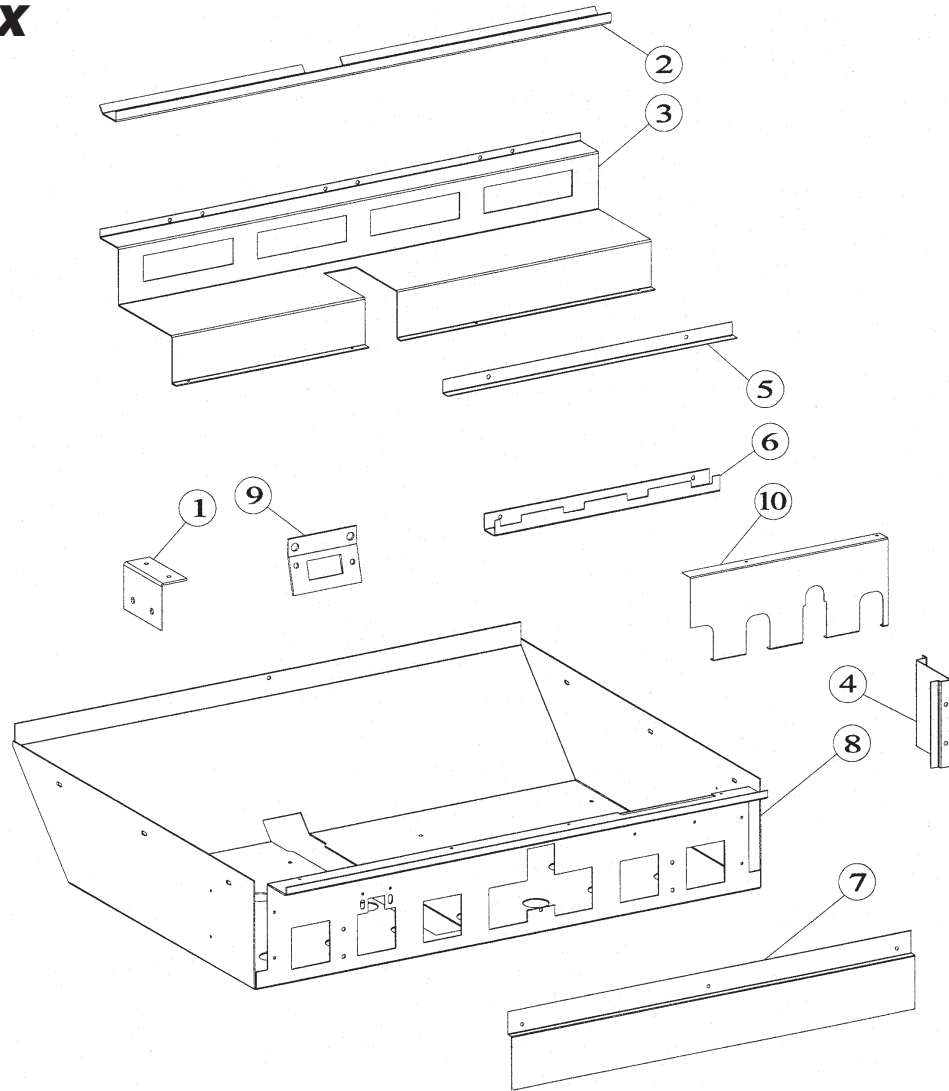

SK2380200
Ignitor protector

ITEM NO.	PART NO.	DESCRIPTION	QTY.
1	2359300	BACK TOP MOUNTING BRACKET	2
2	2360101	REAR COMBUSTION SEAL - 40 GAL.	1
	2360100	REAR COMBUSTION SEAL - 30 GAL.	1
3	2342499	BURNER REST ASSEMBLY - 40 GAL.	1
	2342399	BURNER REST - ASSEMBLY 30 GAL.	1
4	071497-2-9	INSIDE HINGE COVER	2
5	2342602	BURNER TIE DOWN - 40 GAL.	2
	2342600	BURNER TIE DOWN L/H - 30 GAL.	1
	2342601	BURNER TIE DOWN R/H - 30 GAL.	1
6	2445200	SECONDARY BURNER REST R/H - 40 GAL.	1
	2445201	SECONDARY BURNER REST L/H - 40 GAL.	1
	2445300	SECONDARY BURNER REST R/H - 30 GAL.	1
	2445400	SECONDARY BURNER REST L/H - 30 GAL.	1
7	2347800	FRONT SHIELD - 40 GAL.	1
	2347900	FRONT SHIELD - 30 GAL.	1
8	2342200	BURNER PAN - 40 GAL.	1
	2342100	BURNER PAN - 30 GAL.	1
9	2373900	IGNITOR MOUNTING BRACKET	1
10	SK50890	RADIATION SHIELD R/H - 40 GAL.	1
	SK50891	RADIATION SHIELD L/H - 40 GAL.	1
	SK50892	RADIATION SHIELD R/H - 30 GAL.	1
	SK50893	RADIATION SHIELD L/H - 30 GAL.	1

MANIFOLD ASSEMBLY

111585 NAT TO LP STICKER
1115851 LP TO NAT STICKER

Sensor wire
4517368

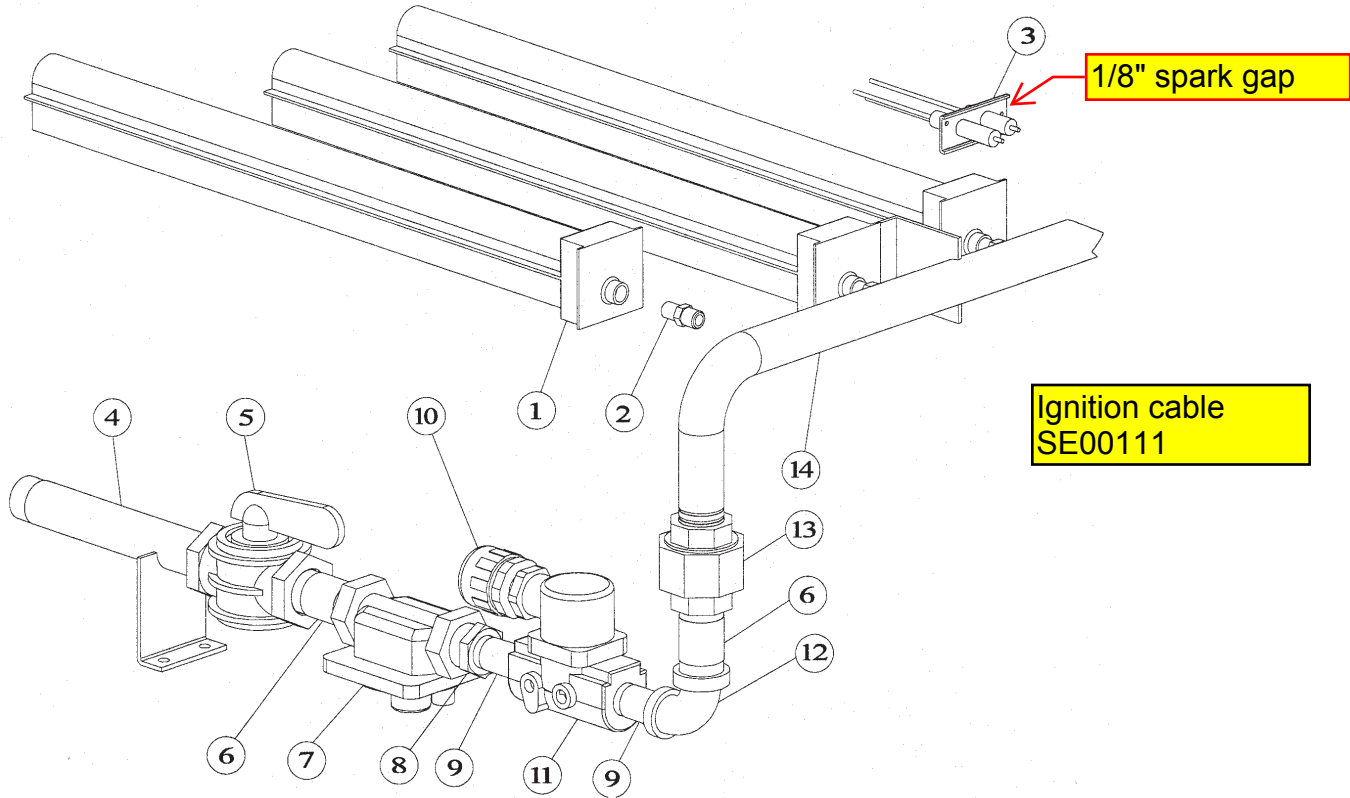

Ignition cable
SE00111

ITEM NO.	PART NO.	DESCRIPTION	QTY.
1	2373100	BURNER (NAT. GAS)7 for 30 gal., 10 for 40 gal.
	KE02410	BURNER (LP GAS)7 for 30 gal., 10 for 40 gal.
2	KE55277-1	ORIFICE, (NAT. GAS), 2000 FT7 for 30 gal., 10 for 40 gal.
	KE55277-5	ORIFICE, (LP), 2000 FT.7 for 30 gal., 10 for 40 gal.
3	KE53437-1	SPARK ELECTRODE1
4	2363599	NIPPLE PLATE ASSY1
5	F01518-1	SHUT-OFF VALVE1
6	N0640C2	NIPPLE 3/4" NPT2
7	KE54618-2	GAS REGULATOR - NATURAL1
	KE54618-1	GAS REGULATOR - LP1
8	FI00336	NPT BUSHING 3/4" X 1/2"1
9	N0440C2	NIPPLE 1/2" NPT X 2"2
10	2361500	LIQUID-TIGHT FITTING1
11	2345700	GAS SOLENOID1
12	FI00357	ELBOW 90° 3/4" X 1/2"1
13	FI00073-1	UNION 3/4" NPT1
14	2339799	MANIFOLD - 40 GAL.1
	2339899	MANIFOLD - 30 GAL.1

MAINTENANCE

NOTE: ANY MAINTENANCE OR SERVICE INVOLVING DISSASSEMBLY OF COMPONENTS SHOULD BE MADE BY A QUALIFIED SERVICE TECHNICIAN. ENSURE GAS, ELECTRICAL AND WATER SUPPLY (IF APPLICABLE) TO THE APPLIANCE ARE SHUT OFF

You have purchased the finest commercial cooking equipment available anywhere. Like any other fine, precision built piece of equipment it should be given regular care and maintenance.

Periodic inspections by your dealer or a qualified service agency are recommended to check temperatures, adjustments and ensure moving parts are operative. Whenever possible, avoid overheating idle equipment as this is the primary cause for increased service costs.

When corresponding with the factory or your equipment dealer regarding service problems or replacement parts, be sure to refer to the particular unit by the correct model number (including prefix and suffix letters and numbers) and the serial or code number. The rating plate affixed to the unit contains this information.

"REGULAR MAINTENANCE ENSURES PEAK PERFORMANCE".

TILT MECHANISM LUBRICATION

The linear actuator (power tilt models), the hydraulic cylinder (manual tilt), and the bronze bushings are all self-lubricating and require no lubrication.

CALIBRATION INSTRUCTIONS

IMPORTANT: DO NOT ATTEMPT TO CALIBRATE THE THERMOSTAT

The electronic thermostat supplied with this skillet has been precisely calibrated at the factory and should not require field calibration.

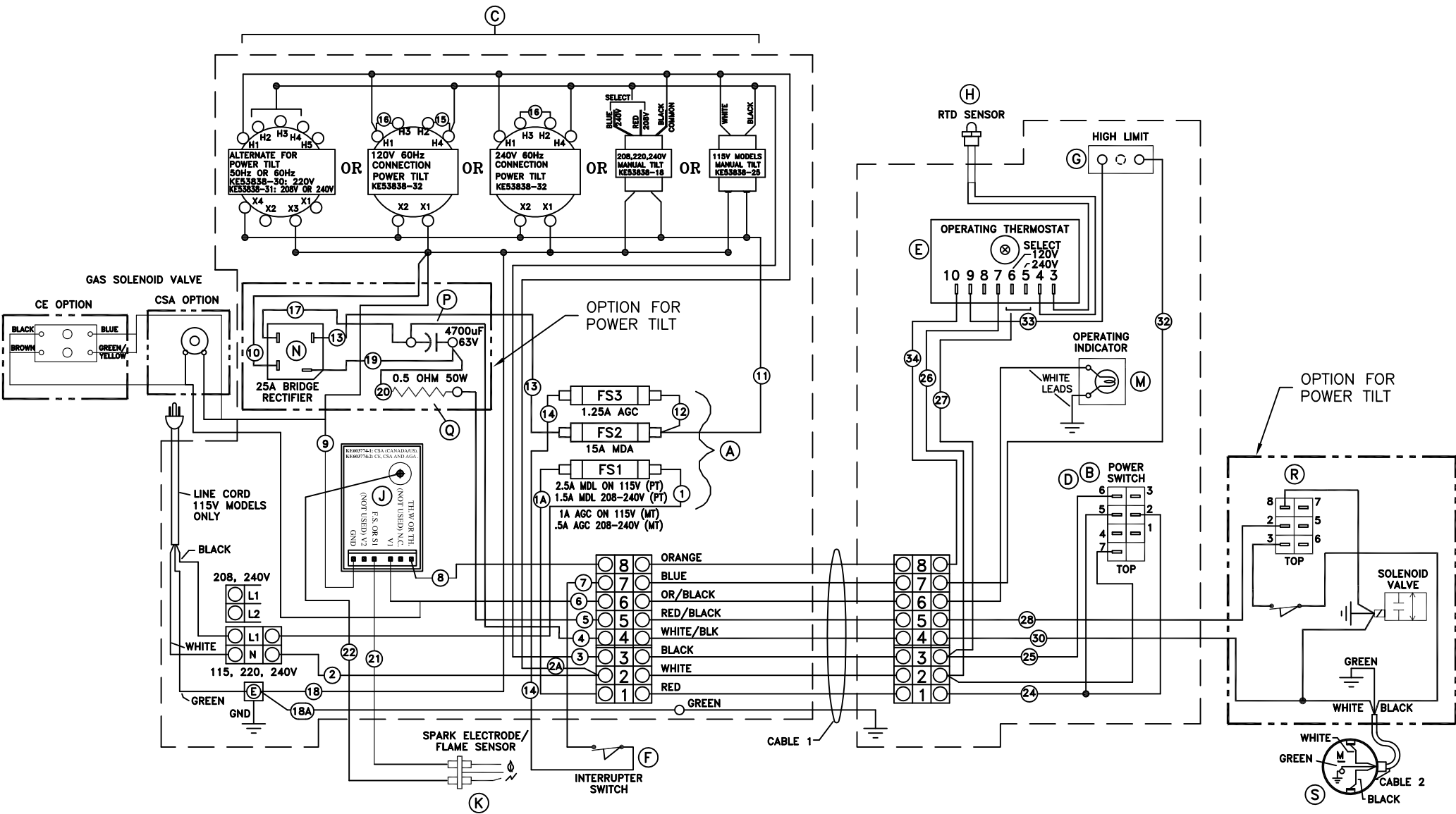

MODEL: SGL,M-30,40TR

After serial number
110823058797

After serial number
110823058797

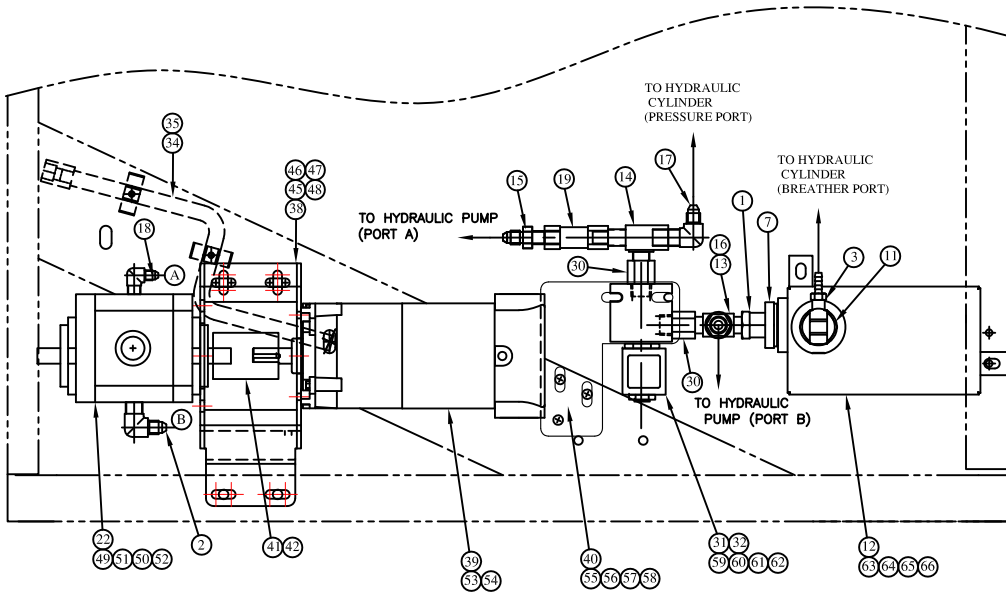

POWER TILT TR SKILLET ASSEMBLY				
ITEM	PART #	DESCRIPTION	QTY.	BOM COMMENTS
1	FI00351	HEX BUSHING;1/2 X 1/4	1	
2	FI05059	ELBOW; STRAIGHT THREAD	1	
3	FI05318-1	ELBOW HOSE BARB 90 BRASS	1	
4	KE000523	HYDRAULIC JACK ASSY TR/F	1	
5	KE53143	PLUG; 1/4-18 HYDRAULIC	1	
6	KE55267	FLOW RESTRICTOR MT/TR	1	
7	KE600452	STRAINER; OIL (MT-TR/F)	1	
8	KE603728	COVER; CONTROL SWITCHES	1	
9	M194	HYDRAULIC OIL; HD68-4L	1	
10	SK2147401	FITTING;LIQUID TIGHT	1	
11	SK2250700	PLUG MODIFD FI00285	1	
12	SK2375699	OIL TANK ASSY MT/TR	1	
13	SK2378900	TEE; 1/4 P (M/F/M)	1	
14	SK2378901	TEE; 1/4 P (F/M/M)	1	
15	SK2379000	ADAPTER; 1/4 P	1	
16	SK2379001	ADAPTER; 1/4 P	1	
17	SK2379100	ELBOW;1/4-90D-	2	
18	SK2379200	ELBOW;O-RING BOSS 90DEG	1	
19	SK2379400	CHECK VALVE PARKER C400B	1	
20				
21	KE95586-2	LABEL; CLEVELAND/PT/TR	1	
22	SK2378802	HYDRAULIC PUMP; TR/F	1	
23	SK2379501	HYDRAULIC HOSE ASSY;22	2	
24	KE50581	BRIDGE RECTIFIER; #MB256	1	
25	KE52936-9	FUSE; 15A/250V/MDA-15-R	1	
26	SK1427305	CAPACITOR;4700MF/63VDC	1	
27	SK2282100	CAPACITOR; CLAMP #VR3	1	
28	SK2343502	SWITCH; TILT SWITCH	1	
29	KE601979	LIMIT SW ;TR- (UL APPV)	1	
30	KE603895	HYDRAULIC HOSE ADAPTER	2	
31	KE54834-17	SOLENOID VALVE	1	
32	KE603873	SOLENOID VALVE CONNECTOR	1	
33	KE003707	HYDRAULIC HOSE ASSY	1	
34	KE003160	HANDLE MANUAL CRANK	1	
35	SK2473800	CLIP; SMALL	2	
36	F10	PAN QUAD SCR #8-32X3/8	2	
37	KE54907-1	PLUG BUTTON	1	
38	KE003705	MOTOR MOUNT BRACKET ASS'Y	1	
39	KE603896	GEARMOTOR, DC	1	
40	KE603898	SOLENOID MOUNTING PLATE	1	
41	KE50582-5	COUPLING HUB 1/2 DIA.	2	
42	KE50583-1	SPIDER	1	
43	SK2147402	LIQUID TIGHT FITTING	1	
44				

NOTES:

- 1.) ITEMS 4, 5, 6, 8, 9, 10, 21, 23, 24, 25, 26, 27, 28, 29, 33, 36, 37, 43, 67, 70, 71, 72 AND 73 ARE NOT SHOWN FOR CLARITY.
- 2.) SEE DRAWING SK95062 FOR WHERE TO MOUNT ITEM#72

ITEM	PART #	DESCRIPTION	QTY.	BOM COMMENTS
FASTENERS FOR THE MOTOR MOUNT BRACKET ASS'Y				
45	FA11260	HEX BOLTS S.S., 1/4-20UNC X 1"	4	
46	FA30505-1	FLAT WASHER S.S., 1/4	8	
47	FA31029	LOCK WASHER S.S., 1/4	4	
48	FA21008	HEX NUT S.S., 1/4-20UNC	4	
FASTENERS FOR THE HYDRAULIC PUMP				
49	FA11325	HEX BOLTS S.S., 15/16-18UNC X 1 1/4"	2	
50	FA30505-5	FLAT WASHER S.S., 5/16	2	
51	FA31030	LOCK WASHER S.S., 5/16	2	
52	FA21024	HEX NUT S.S., 5/16-18UNC	2	
FASTENERS FOR GEARMOTOR				
53	FA11148	10-32UNF X 3/4 PAN PHIL M/S 18-8 S.S.	4	
54	FA32022	EXT. TOOTH LOCK WASHER S.S., #10	4	
FASTENERS FOR SOLENOID MOUNTING PLATE				
55	FA11260	HEX BOLTS S.S., 1/4-20UNC X 1"	2	
56	FA30505-1	FLAT WASHER S.S., 1/4	4	
57	FA31029	LOCK WASHER S.S., 1/4	2	
58	FA21008	HEX NUT S.S., 1/4-20UNC	2	
FASTENERS FOR SOLENOID VALVE				
59	FA11509-4	HEX BOLTS S.S., 1/4-20UNC X 1 3/4"	2	
60	FA30505-1	FLAT WASHER S.S., 1/4	4	
61	FA31029	LOCK WASHER S.S., 1/4	2	
62	FA21008	HEX NUT S.S., 1/4-20UNC	2	
FASTENERS FOR TANK				
63	FA11148	10-32UNF X 3/4 PAN PHIL M/S 18-8 S.S.	1	
64	FA32022	EXT. TOOTH LOCK WASHER S.S., #10	1	
65	FA30505-2	FLAT WASHER S.S., #10	1	
66	FA21006	HEX NUTS 18-8 S.S., #10-24UNC	1	
FASTENERS FOR TILTING LIMIT SWITCH				
67	FA11148	10-32UNF X 3/4 PAN PHIL M/S 18-8 S.S.	2	WAS QTY. 4
68	FA32022	EXT. TOOTH LOCK WASHER S.S., #10	2	
69	FA21006	HEX NUTS 18-8 S.S., #10-24UNC	2	
70	FA30505-9	SAE FLAT WASHERS S.S., 1/4	2	
71	FA31029	LOCK WASHERS 18.8, 1/4	2	
73	FA11260	HEX BOLTS S.S., 1/4-20UNC X 1"	2	
PAN WITH TD OPTION				
72	KE603877-1	LIMIT SWITCH MOUNTING BRACKET	1	
PAN WITHOUT TD OPTION				
72	KE603877-2	LIMIT SWITCH MOUNTING BRACKET	1	