

"SPLASH PROOF"
ELECTRIC TABLE TYPE, RECTANGULAR,
10 GALLON (40 LITER)

Project _____
Item _____
Quantity _____
FCSI Section 11400 _____
Approved _____
Date _____

Models

- SET-10



Shown with optional Support Stand (ST28)

Standard Features

- Heat Element are cast integrally into 1.25" (32mm) thick aluminum blocks which are securely camped to the underside of the cooking surface, providing even heat distribution and energy efficiency with rapid heat-up
- Stainless Steel Cooking Surface is structurally braced to prevent warping
- Splash Proof
- Bead-blast Textured Cooking Surface Finish to reduce sticking
- Two Position Cooking Setting-Horizontal and 9° forward Tilt
- Skillet and Frame are Type 304 Stainless Steel Construction, with #4 Finish
- Thermostat Control conveniently located in a Drip Proof Side Console. Temperature Controlled from 190°F (88°C) to 440°F (227°C)
- Sanitary Base Mounting for Table Top Installation
- Standard 208 or 240 Volts, 60 Hz, 3 Phase, 3 Wire
- Lift-Off Cover
- Typical approvals include UL, CSA, CE and NSF

Short Form Specifications

Shall be CLEVELAND 10 Gallons (40 liters) Model SET-10 _____; _____ KW _____ Volt, Rectangular Tilting Skillet of type 304 Stainless Steel Construction, with #4 Finish. Electric Heating Elements cast integrally onto 1.25"/32mm thick aluminum blocks and securely clamped beneath cooking surface. Bead-Blast-Textured Cooking Surface. Complete with Thermostatic, Safety and Main Power Controls with Lighted Indicators. For Table Top Mounting. Lift-Off Cover.

Options & Accessories

- Poaching Pans (PP)
- Vegetable Steamer (VS)
- Double or Single Water Faucet with Swing Spout (DPS) or (SPS)
- Stainless Steel Support Stands (ST28) with Sliding Drain Drawer and Splash Screen
- Voltages other than standard (VOS)
- Single phase option (SPH)
- Food Strainer (SF15)

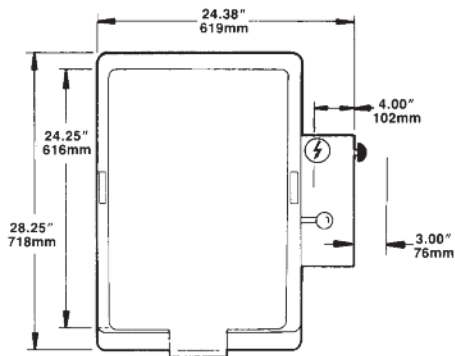
CAPACITIES

In 4 oz. servings. Other sizes may be calculated.
 10 gallons / 40 Liters 320

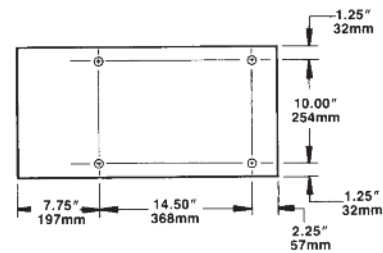
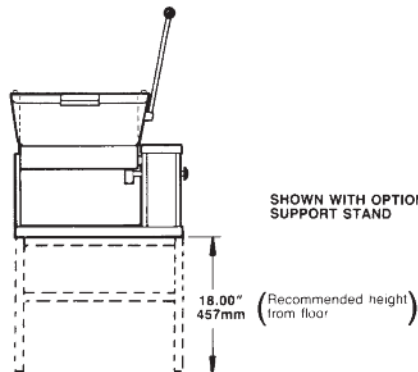
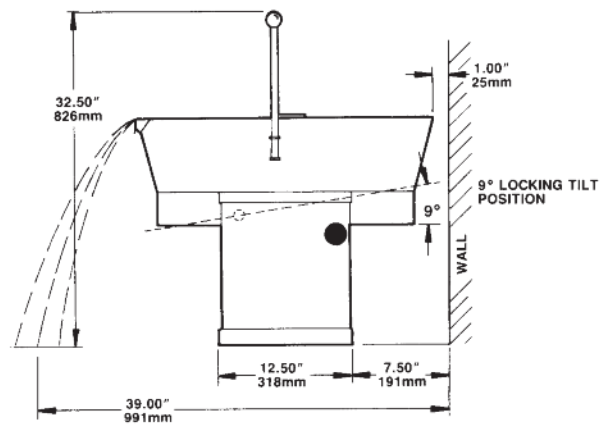
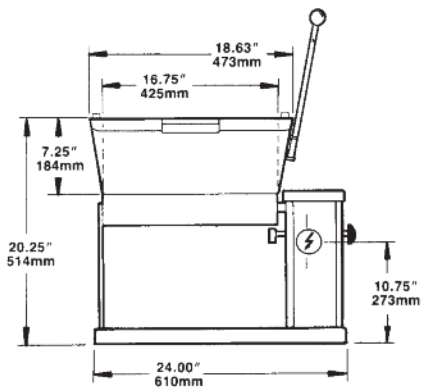

5/16" - 18 THREADED FERRULES
 WELDED TO UNDERSIDE OF BASE

**MOUNTING DIAGRAM
 TOP VIEW**

ELECTRIC ⚡											CLEARANCE		
GALS. LITERS		208 VOLTS			240 VOLTS			220 /380 VOLTS			RIGHT = 3.00"	LEFT = 0"	REAR = 1.00"
		AMPS			AMPS			AMPS					
		KW	1 PH	3 PH	KW	1 PH	3 PH	KW	1 PH	3 PH			
10	40	7.4	35.4	20.5	7.8	32.7	18.9	6.5	N/A	9.9			

DUAL VOLTAGE OF 220/380 SHOWN ON CHART REQUIRES A FOUR WIRE, THREE PHASE ELECTRICAL SUPPLY.

NOTES:

Cleveland Range reserves right of design improvement or modification, as warranted.
 Many regional, state and local codes exist and it is the responsibility of the owner and installer to comply with the codes.
 Cleveland Range equipment is built to comply with applicable standards for manufacturers. Included among those approval agencies are U.L., NSF, CGA, CSA, ETL and others.

(NOT TO SCALE)