

# DURAPAN™ SERIES

ELECTRIC, OPEN OR MODULAR BASE,  
30 & 40 GALLON (115 & 150 LITER)

Project \_\_\_\_\_  
 Item \_\_\_\_\_  
 Quantity \_\_\_\_\_  
 FCSI Section 11400 \_\_\_\_\_  
 Approved \_\_\_\_\_  
 Date \_\_\_\_\_

## Models

- SEL-30-TR • SEM-30-TR
- SEL-40-TR • SEM-40-TR



Open base model shown with optional  
Drain Drawer (SLD)

- Space-Saving Design- No Clearance Required at rear or sides (optional Faucet and Console requires 4 1/2" on one side)
- All Stainless Steel Construction for durability and easy cleaning
- Adjustable, Electronic Thermostat controls temperature from 100°F to 425°F
- High Efficiency Heating System with even heat distribution - 14 kW's for 30 gallon models, 18 kW's for 40 gallon models
- Fast Heat-Up and Recovery Time-Preheats in 15 minutes, full capacity from cold to boiling in 60 minutes
- Spring Assist Cover with Adjustable Vent and Full Width Handle
- On/Off Switch, Thermostat Knob and Pilots, recessed to avoid breakage
- Four Stainless Steel, Level adjustable feet, rear flanged for bolting
- Serviceable from the front of the unit
- Two Pilot Lights; Green = Power on, Amber = Temperature Cycling
- Splash Proof Controls and Water Tight Electrical Connections
- High Limit Safety Device set at 450°F (232°C)
- Anti-Splash Pouring Lip
- Typical approvals include UL, CSA, CE and NSF

## Short Form Specifications

Shall be CLEVELAND, Tilting Skillet;  
 Model SE - \_\_\_\_\_ - TR \_\_\_\_\_ KW, \_\_\_\_\_ Volts  
 holding no less than \_\_\_\_\_ gallons ( \_\_\_\_\_  
 liters); Complete with thermostatic and Safety  
 Controls; Gallon Markings; Stainless Steel Clad;  
 5/8" Cooking Surface; Hand Tilt; Spring Assist  
 Cover with adjustable Vent. All Stainless Steel  
 Construction. No Clearances Required.

## Standard Features

- Leg or Modular Base
- Full 30/40 Gallon (115/150 Liters) Capacity Rating to Bottom of Pouring Lip
- Hydraulic Hand Tilt with quick lowering feature (HTS)
- Stainless Steel Clad 5/8" Cooking Surface Guaranteed against warpage
- Stainless Steel Coved Cornered Pans with both Gallon and Liter Markings

## Options & Accessories

- Sliding Drain Drawer with Splash Screen (SLD) (for SEL models only)
- Power Tilt with Hand Tilt Override (PT1)
- Double or Single Pantry Faucet (SPS14, DPS14), includes Faucet Mounting Bracket
- Double or Single Pantry Skillet Filler with 60" hose (SKF-S or DKF-S)
- Hot & Cold Water Pre-Rinse Spray Head with Hose (PRS-S)
- Voltage Options:
  - VOSK1, 240 Volt, 60 Hz, 3 Phase
  - VOSK2, 380/415 Volt, 50 Hz, 3 Phase - for export
  - VOSK3, 440/480 Volt, 60 Hz, 3 Phase
- Food Strainers for pouring spout (FS)
- Vegetable Steamers (VS)
- Poaching Pans (PP)
- Wall Mounting (WMS)
- In-Wall Carriers (IWCS)
- Pan Carriers (PCS), not available on 30 gallon models with a Tangent Draw-Off Valve
- 2" Tangent Draw-Off Valve (TD2), left side only

MODEL	A	B	C	D	E	F	G
SEL-30-TR	36"	32"	9"	5"	20"	3"	32 7/8"
	(915mm)	(812mm)	(229mm)	(127mm)	(508mm)	(76mm)	(835mm)
SEL-40-TR	48"	44"	12 1/8"	8"	22"	6"	44 7/8"
	(1220mm)	(1118mm)	(308mm)	(203mm)	(559mm)	(153mm)	(1140mm)

**CAPACITIES**

In 4 oz. servings. Other sizes may be calculated.  
 30 gallons / 115 Liters ..... 960  
 40 gallons / 150 Liters ..... 1280

**SPECIFICATIONS**

CLEARANCE	APPROX. SHIPPING WEIGHTS
<b>RIGHT:</b> 1" (26mm) (4 1/2"/115mm with Faucet)	<b>SEL-30-TR</b> 420 LBS. 191 KG.
<b>LEFT:</b> 1" (26mm)	
<b>REAR:</b> 1" (26mm)	<b>SEL-40-TR</b> 490 LBS. 223 KG.



EXTERIOR HINGES (REQUIRED FOR OPTIONAL TD 2)

**ELECTRICAL**

SEL-30-TR & SEM-30-TR (Standard Wattage)						
Volts	Ph	Hz	Total Watts	Amps	Wire Size	
208	1	60	14400	69.2	4	
208	3	60	14400	40	8	
240	1	60	14400	60	6	
240	3	60	14400	34.6	8	
380	1	50	14400	37.9	8	
380	3	50	14400	21.9	10	
416	1	50	14400	34.6	8	
416	3	50	14400	20	10	
480	1	60	14400	30	8	
480	3	60	14400	17.3	10	

SEL-40-TR & SEM-40-TR (Standard Wattage)						
Volts	Ph	Hz	Total Watts	Amps	Wire Size	
208	1	60	18000	86.5	3	
208	3	60	18000	50	6	
240	1	60	18000	75	4	
240	3	60	18000	43.4	8	
380	1	50	18000	47.3	6	
380	3	50	18000	27.3	10	
416	1	50	18000	43.3	6	
416	3	50	18000	25	10	
480	1	60	18000	37.5	6	
480	3	60	18000	21.7	10	

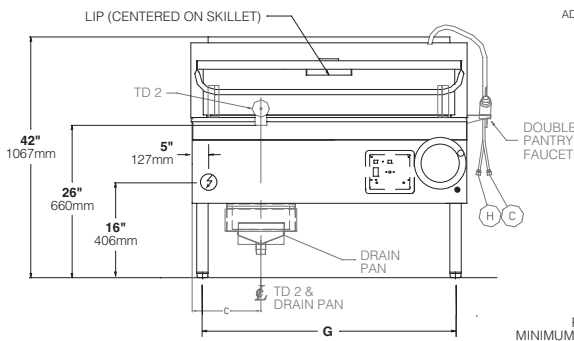
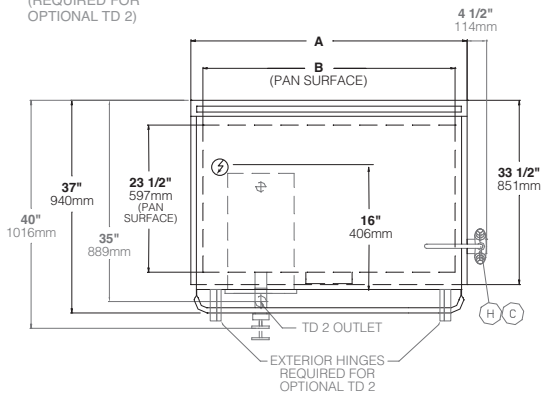

NOTE: NON STANDARD ITEMS ARE SHOWN IN GRAY

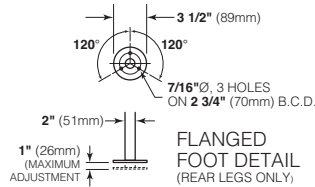
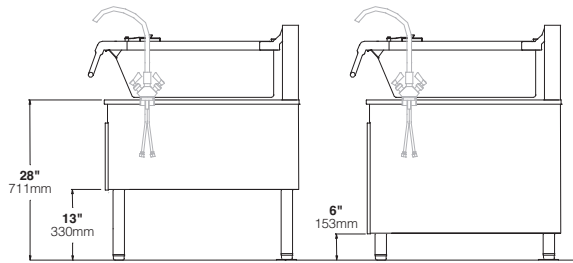
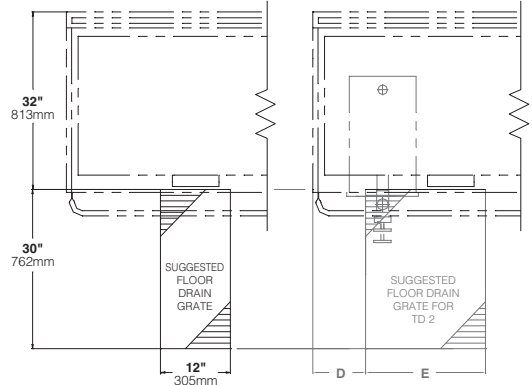

FLANGED FOOT DETAIL (REAR LEGS ONLY)

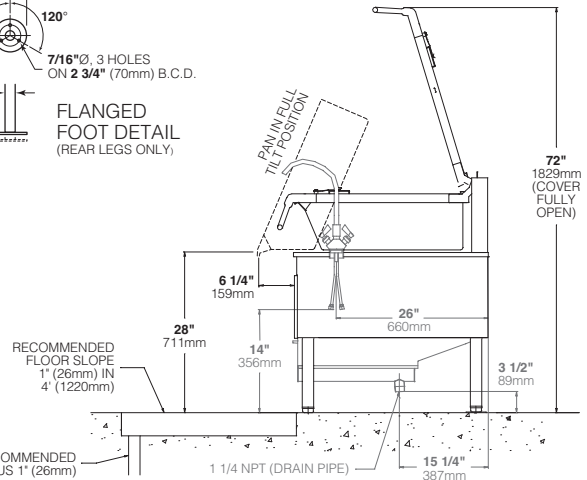
**NOTES:**

Cleveland Range reserves right of design improvement or modification, as warranted.  
 Many regional, state and local codes exist and it is the responsibility of the owner and installer to comply with the codes.  
 Cleveland Range equipment is built to comply with applicable standards for manufacturers. Included among those approval agencies are U.L., NSF, CGA, CSA, ETL and others.

(NOT TO SCALE)