

EQUIPMENT STAND WITH DRAIN,  
ENCLOSED; WITH LEGS, SLIDING DRAIN CATCH PAN AND  
SPLASH SHIELD 450, 650, 760, 1050, 1200, 1600 OR 1800MM  
WIDE TABLE WITH DRAIN

Project \_\_\_\_\_  
 Item \_\_\_\_\_  
 Quantity \_\_\_\_\_  
 FCSI Section 11400 \_\_\_\_\_  
 Approved \_\_\_\_\_  
 Date \_\_\_\_\_

**Models**

- SD-450      • SD-1050      • SD-1800
- SD-650      • SD-1200
- SD-760      • SD-1600

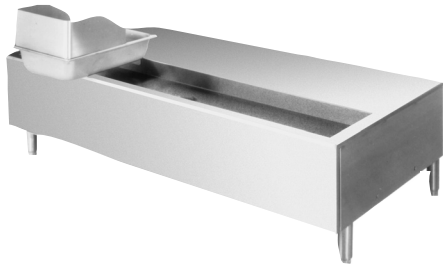

**Standard Features**

- Type 430 Stainless Steel, welded construction, #4 finish
- 6" Stainless Steel legs with level adjustment
- Full width drain trough with center drain outlet fitted with standard male drain connection
- Sliding drain catch pan with screened outlet and splash shield
- Enclosed cabinet-style base
- Suitable for kettles, mixer kettles, skillets, etc.
- 18" height (450mm) matches "Low Boy" mounted equipment

**Options & Accessories**

- Flanged feet (FF)

**Short Form Specifications**

Shall be CLEVELAND, equipment stand (with drain), adjustable legs 18" high, with \_\_\_\_\_ mm wide table top. (Measured left to right.) Type 430 Stainless Steel construction with #4 finish. Full width drain trough, having center outlet with standard male drain connection, sliding drain catch pan with screened outlet.

Model No.		A	B	C
SD- 450	IN mm	17.72 450	14.78 375	8.86 225
SD- 650	IN mm	25.59 650	73.86 1876	12.79 325
SD- 760	IN mm	29.92 760	26.98 685	14.96 380
SD-1050	IN mm	41.34 1050	38.40 975	20.67 525
SD-1200	IN mm	47.24 1200	44.30 1125	23.62 600
SD-1600	IN mm	62.99 1600	60.05 1525	31.50 800
SD-1800	IN mm	70.87 1800	67.93 1725	35.44 900

Model	Space Needed
KDT- 6-T	18"
KDT-12-T	23"
KDT-20-T	28"
KET- 6-T	24"
KET-12-T	27"
KET-20-T	32"
MKDT-12-T	24"
MKDT-20-T	30"
MKET-12-T	27"
MKET-20-T	32"
SET-10	24"
SET-15	31"

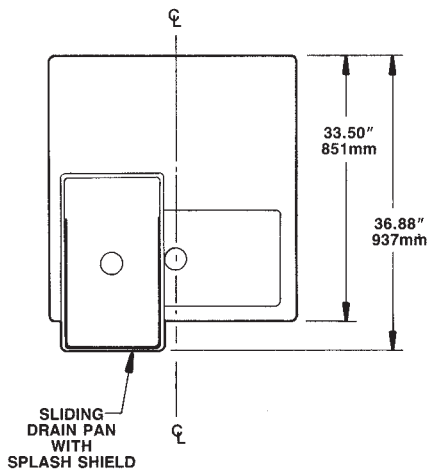

**NOTE:** To determine table width of SD stand, add widths of all equipment to be mounted, add 4" total for end clearances and add 4" between each unit.

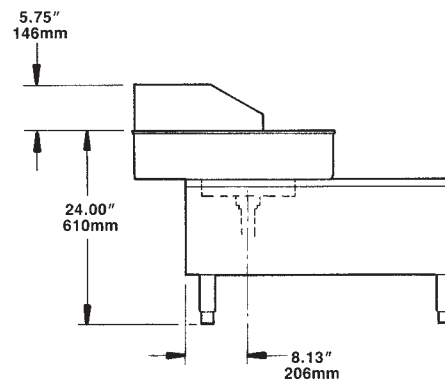
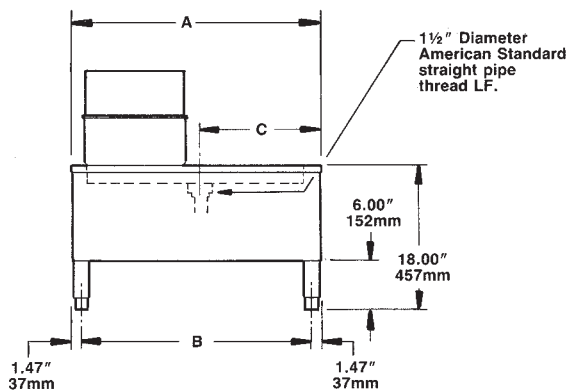

**NOTES:**

Cleveland Range reserves right of design improvement or modification, as warranted.  
 Many regional, state and local codes exist and it is the responsibility of the owner and installer to comply with the codes.  
 Cleveland Range equipment is built to comply with applicable standards for manufacturers. Included among those approval agencies are U.L./NSF#4 and CSA (AGA, CGA).

(NOT TO SCALE)