

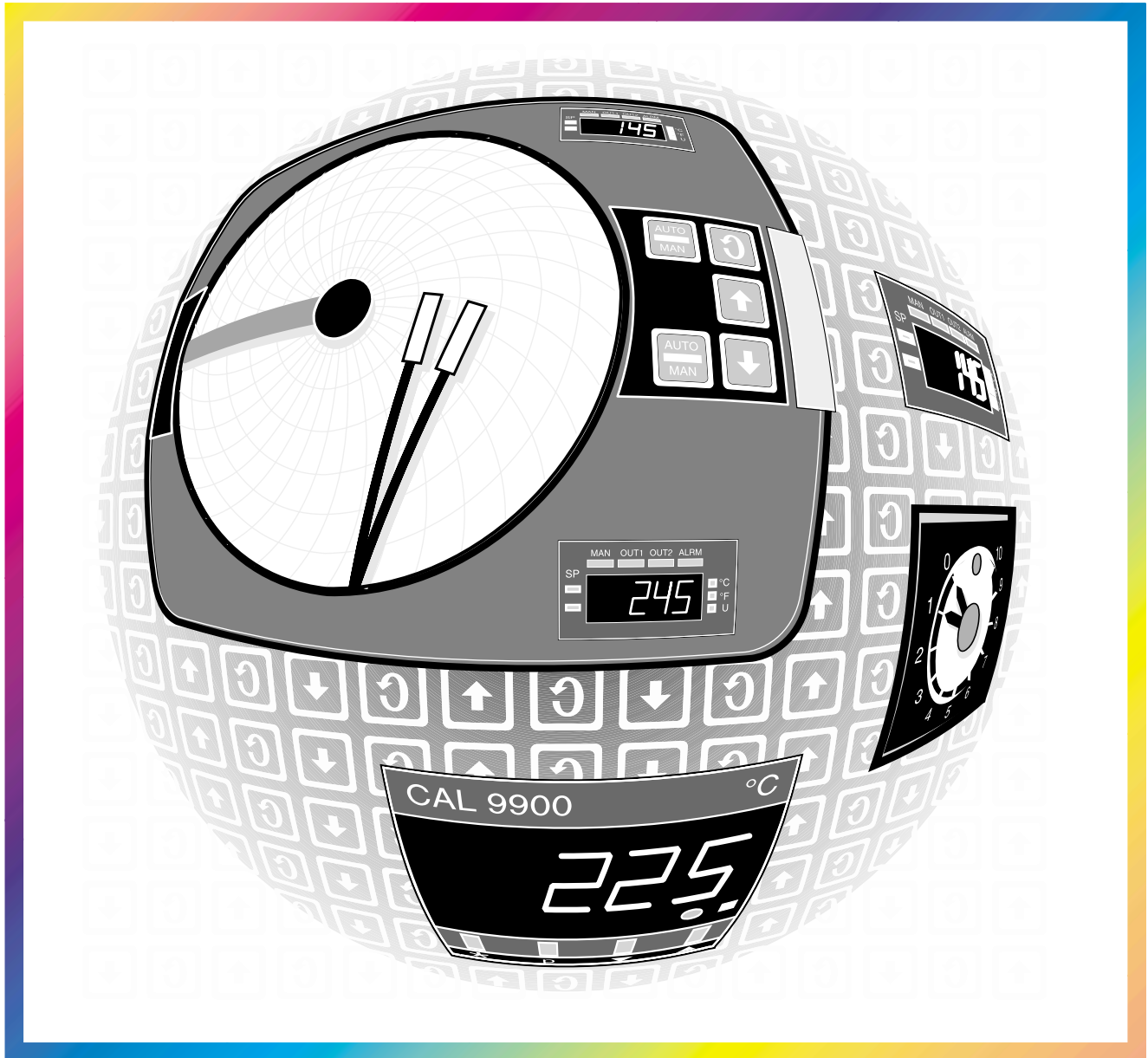

Operators Manual

Installation, Operation & Service

Digital & Analog Controllers used on Cleveland Range Kettles and Cook Tanks



Enodis

1333 East 179th St., Cleveland, Ohio, U.S.A. 44110

Phone: (216) 481-4900 Fax: (216) 481-3782
Visit our web site at www.clevelandrange.com

TABLE OF CONTENTS

Operating Instructions

<i>MRC 7000 Controls Drawing (1 Pen)</i>	1
<i>Mixer Kettle Operation using MRC 7000 (1 Pen)</i>	1
<i>Mixer Kettle Operation using MRC 7000 (1 Pen)</i>	1
<i>CAL 9900 Controls Drawing</i>	2
<i>Mixer Kettle Operation using CAL 9900</i>	2
<i>Changing Functions and Options (CAL 9900)</i>	2
<i>Cleveland Range Factory Settings (CAL 9900)</i>	2
<i>MRC 7000 Controls Drawing (2 Pen)</i>	3
<i>Cook Tank Operation using MRC 7000 (2 Pen)</i>	3
<i>Digital Water Meter Controls Drawing</i>	4
<i>Digital Water Meter Meter Operating Instructions</i>	4
<i>Left Hand View of Digital Water Meter Controls</i>	4
<i>Digital Water Meter Meter Operating Instructions</i>	5
<i>Configuring a Digital Water Meter</i>	5

Programming Instructions

<i>MRC 7000 Enable Mode Procedure (1&2 Pen)</i>	6
<i>MRC 7000 Enable Mode Flow Chart (1&2 Pen)</i>	6
<i>MRC 7000 Software Reference/Record Sheet</i>	7
<i>MRC 7000 General Programming Instructions (1 Pen)</i>	8-9
<i>Program Mode (Prog)</i>	8
<i>Tune Mode (TunE)</i>	9
<i>Calibration Mode (CAL)</i>	9
<i>Enable Mode (EnAb)</i>	9
<i>Jumpers on Process Board</i>	9
<i>MRC 7000 General Programming Instructions (2 Pen)</i>	10-11
<i>Program Mode (Prog)</i>	10
<i>Tune Mode (TunE)</i>	11
<i>Calibration Mode (CAL)</i>	11
<i>Enable Mode (EnAb)</i>	11
<i>Jumpers on Process Board</i>	11
<i>Horizontal Mixer Kettles -</i>	
<i>AC Inverter Programming Instructions</i>	12
<i>Program Code Summary</i>	12-13

OPERATING INSTRUCTIONS

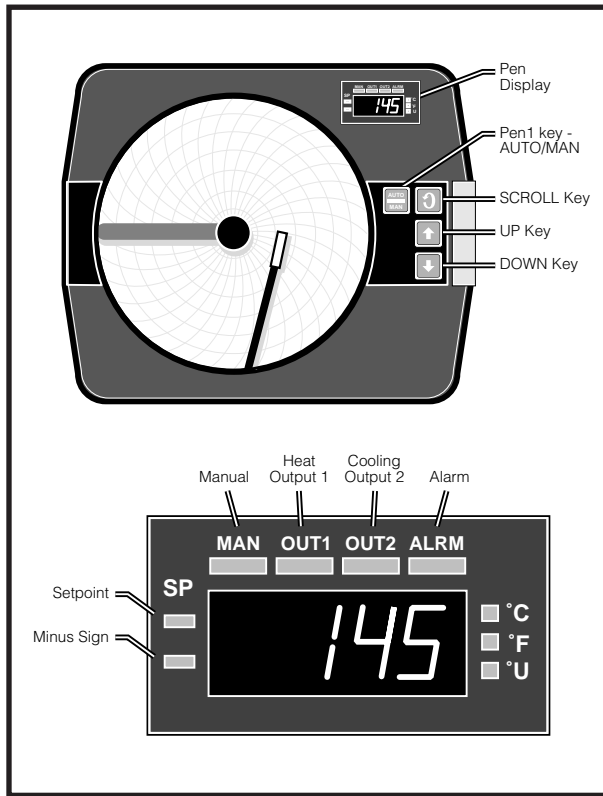

MRC 7000 Controls Drawing (1 pen)

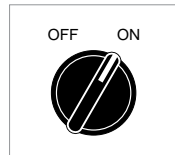

MIXER KETTLE OPERATION USING MRC 7000 (1 PEN)

Note: Temperature probe on mixer bridge must be covered with a minimum of three inches of product to function correctly.

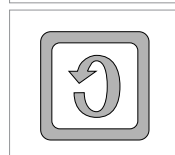
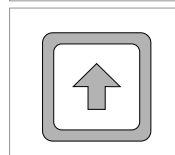
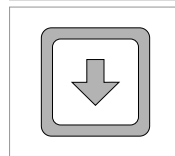
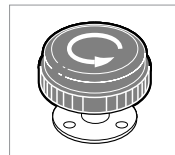
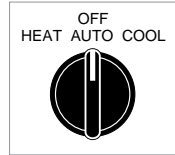

1. Turn MAIN POWER switch to "ON".
2. Turn HEAT/COOL switch to "OFF/AUTO".
3. Turn ACTIVE/BYPASS switch to "ACTIVE".
4. Open steam valve completely.
5. Push and hold key "↓" or "↑" until desired temperature is set.
6. To **start**: push function key "↻" until "Ctrl" is displayed.
7. Push down key "↓".
8. To **stop**: push function key "↻" until "OFF" is displayed.
9. Push down key "↓".

NOTE: For twin kettles, the MRC 7000 will control the kettle the mixer is in.

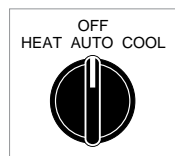

If the unit is used continually it may be simpler to control the "ON/OFF" function with the following steps:

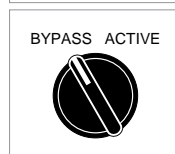

1. Keep HEAT/COOL switch at "OFF/AUTO".
2. To stop turn ACTIVE/BYPASS switch to "BYPASS".



3. To change temperature setting push and hold key "↓" or "↑" until desired temperature is set.
4. To start, turn ACTIVE/BYPASS switch to "ACTIVE".

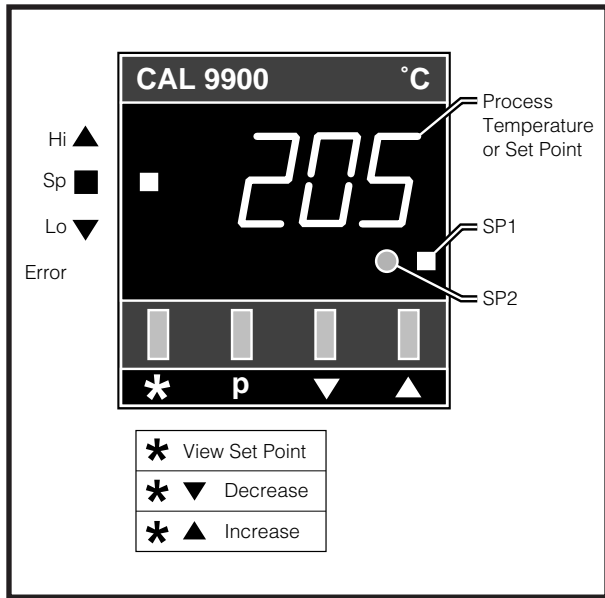

CAL 9900 Controls Drawing

MIXER KETTLE OPERATION USING CAL 9900

Note: Temperature probe on mixer bridge must be covered with a minimum of three inches of product to function correctly.

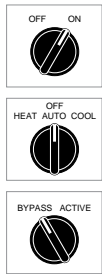

1. Turn mixer MAIN POWER switch to "ON" (CAL 9900 lights up and displays present temperatures).
2. Turn HEAT/COOL switch to "OFF/AUTO".
3. Turn ACTIVE/BYPASS switch to "BYPASS". The unit should not be heating or cooling at this point.
4. Push (*) button on CAL 9900 to read set point temperature. (This is the desired product temperature).
5. To change set point temperature push and hold (*) button while pushing (▲) or (▼) button. New set point is determined when (*) button is released.
6. Add product to kettle.
7. Turn ACTIVE/BYPASS switch to "ACTIVE". If the set point temperature is higher than the product temperature, the kettle will start heating.

Note: For twin kettles, the CAL 9900 will control the kettle the mixer is in.

Changing Functions and Options

The controller has been preset at the factory and should operate satisfactory. If you wish to fine tune the unit for your specific application consult the CAL 9900 Installation and Operation Manual. Following is a simplified procedure for changing parameters.



1. Mixer MAIN POWER switch in the "ON" position.
2. ACTIVE/BYPASS switch in "BYPASS" position.
3. Press button labeled (p). The display should show a number with a decimal place in it.

Left of the decimal place is the **OPERATING MODE** setting (this number should be flashing).

To the right is the **FUNCTION NUMBER**.

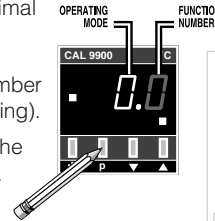

4. To change the **OPERATING MODE** setting push the (▲) or (▼) buttons.



5. To move to the **FUNCTION NUMBER** (right of the decimal) push (*) button.



6. That number should now be flashing. To move to another **FUNCTION NUMBER** push the (▲) or (▼) buttons.



7. Push (*) button to move to the left of the decimal. To change the **OPERATING MODE** setting push the (▲) or (▼) buttons.

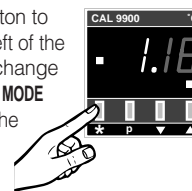

8. When your changes are complete push the button labeled (p) again to return to the Process Temperature.

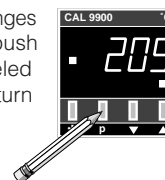

Cleveland Range Factory Settings

OPERATING MODE	FUNCTION NUMBER
0	0
0	1
5	2
0	3
4 steam 5 electric	4
0	5
5	6
0	7
0	8
1	9
0	10
0	11
0	12
0	13
0	14
0	15
9	16
0	17
0	18
1	19
2 T.A.P 0	20
0	21
0 = °C 1 = °F	22
6	23
--	24
0	25
--	26

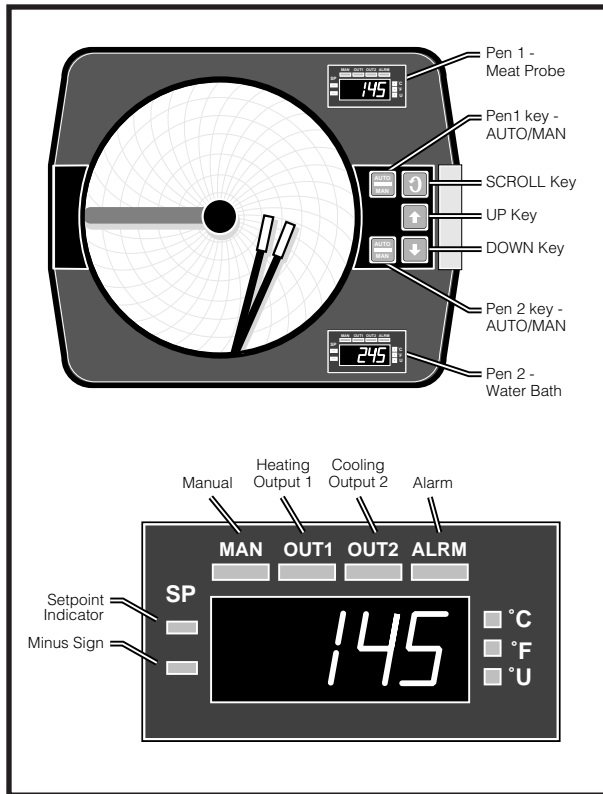

MRC 7000 Controls Drawing (2 pen)

COOK TANK OPERATION USING MRC 7000 (2 PEN)

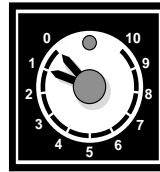

Setting must be done in this order:

1. Set timer by rotating dial.

Note: Turn past one hour and then set time - a minimum of 15 minutes is required for cook tank to work correctly.

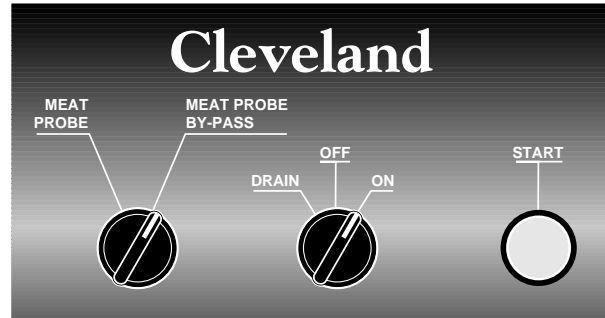

2. Turn right hand switch to "ON".
3. Set left hand switch to "MEAT PROBE" or "MEAT PROBE BY-PASS".

4. Set temperatures on chart recorder.

A. WATER BATH TEMPERATURE:

1. Push and release key "↓".

Note: A green light will come on in the bottom display window underneath the S.P. (set point) symbol. This temperature can be altered as long as this light is on.

2. Push key "↑" or "↓" to set temperature.

B. MEAT PROBE TEMPERATURE:

1. Push and release key "↑".

NOTE: A green light will come on in the top display window underneath the S.P. (set point) symbol. This temperature can be altered as long as this light is on.

2. Push key "↑" or "↓" to set temperature.

Note: Once MRC 7000 is turned on, it will remain on even when the power switch is turned off.

Steps **D** and **E** are only necessary when the display is alternating between "OFF" and the temperature display.

To turn on:

- D.** Push function key "⌂" until "Ctrl" is displayed.

- E.** Push and release the key "↓".

5. Push "START" button.

DIGITAL WATER METER OPERATING INSTRUCTIONS -

USED PRIOR TO SEPT. 97

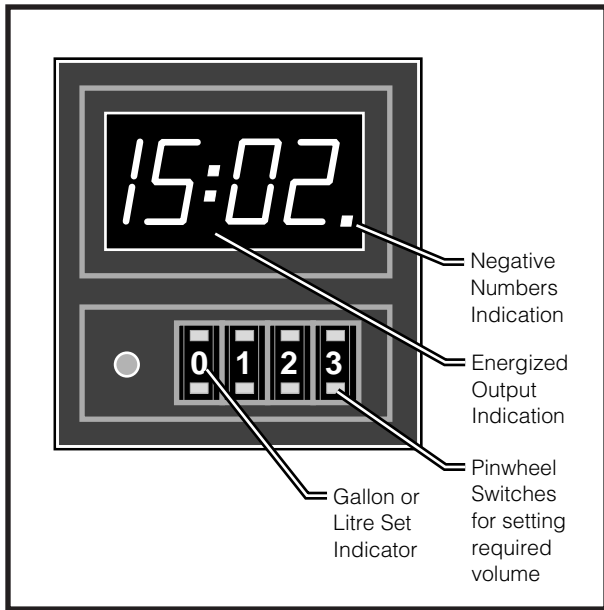

Digital Water Meter Controls Drawing

Dip Switch Programming

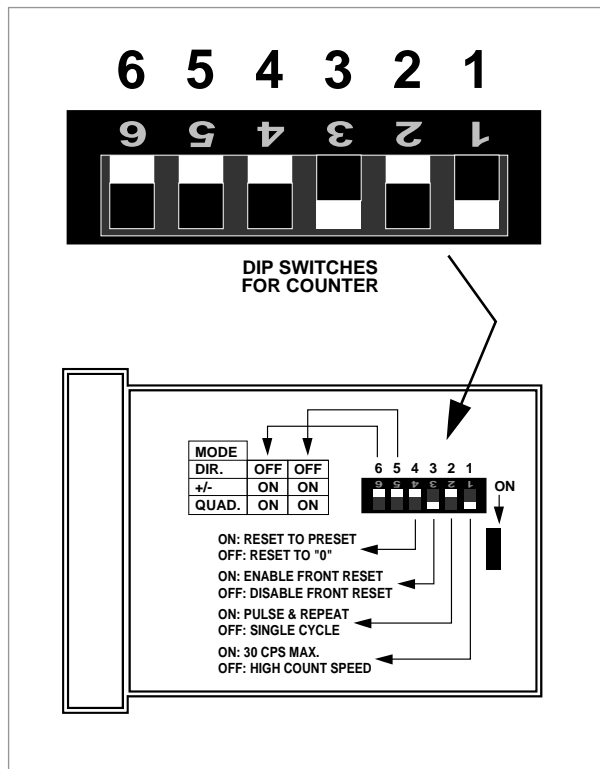

Left Hand View of Digital Water Meter Controls

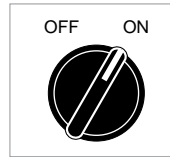

1. Turn POWER switch "ON".



2. Set required volume by pushing upper or lower PINWHEEL SWITCHES to change each number. Do not exceed kettle capacity.



3. Locate delivery spout over desired kettle.

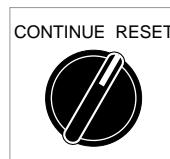

4. Turn START switch to "RESET". Delivery will start at "0" and stop at preset volume.

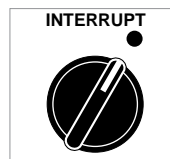

5. To stop delivery at any time, turn INTERRUPT switch to "●".

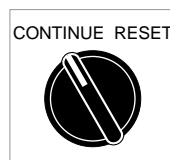

6. To complete delivery after interrupting, turn START switch to "CONTINUE".

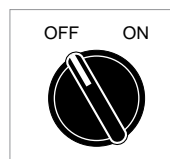

7. Turn POWER switch to "OFF" when meter is not in use

DIGITAL WATER METER OPERATING INSTRUCTIONS -

USED AFTER SEPT. 97

Note: The digital counter has been preset at the factory and should operate satisfactory. If installing a new counter (or the configuration settings to your existing digital counter become corrupted) you must configure the digital counter as shown below (**Configuring a Digital Counter**) prior to operation.

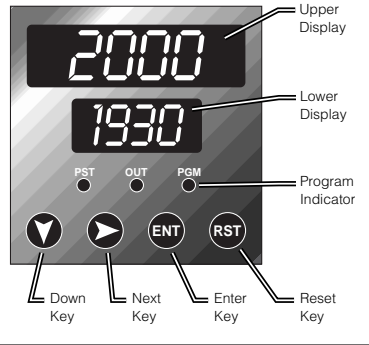

- 3** Locate delivery spout over desired kettle.
- 4** Turn START switch to "RESET". Delivery will start at "0" and stop at preset volume.
- 5** To stop delivery at any time, turn INTERRUPT switch to "•".
- 6** To complete delivery after interrupting, turn START switch to "CONTINUE".
- 7** Turn POWER switch to "OFF" when meter is not in use.

1 Turn POWER switch "ON".

2 Set required volume by first pushing the key until the digit you want to change is flashing in the lower display. Then use the key to change the value of the selected digit. When all digits are set, press the ENT key.

CONFIGURING A DIGITAL COUNTER

This procedure is only necessary when installing a replacement counter or settings to existing counter become corrupted.

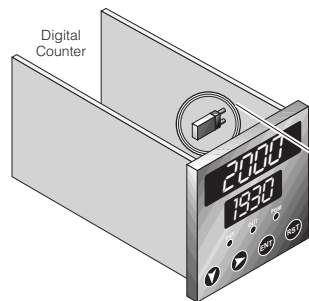

Changing to Configuration Mode

- 1** To enter Configuration Mode, turn POWER switch "OFF" and remove counter from its' housing.
- 2** Change the position of the jumper. **Note:** The actual position is irrelevant, as long as the position is changed.
- 3** Replace the counter in its' housing and turn POWER switch "ON".

Editing the Parameter Settings

After changing the jumper position (see above instructions - **Changing to Configuration Mode**), edit the parameters as follows:

Note: The PGM (program) indicator will flash while the counter is in the configuration mode.

- 1** Use the key to step through the parameters.
- 2** When the desired parameter description is shown in the upper display (see *Parameters Chart*), press the key to enter the edit mode and to scroll through the available settings.
- 3** When the desired setting is shown, press the ENT key.
- 4** To exit the Configuration Mode, momentarily remove power from counter or press and hold down the RST key for at least two seconds.

Parameters Chart	Parameter Description (Upper Display - in order of appearance)	Required Settings (Lower Display)
Counter Speed	SPEE	20 20 Hz.
Input Operation	INPU	A-B A-B (Add/Subtract)
Panel Reset Key	PR-ES	EnAb Enable
Auto Reset	AR-ES	EnAb Enable
Input Pull-Ups	PULL	no No (Current-Sourcing)
Count Direction	Cdir	uP Up-Counting
Lock Strategy	LOC	none None

Use key to step through parameters.

Use key to step to setting shown below.

PROGRAMMING INSTRUCTIONS

MRC 7000 ENABLE MODE PROCEDURE (1&2 PEN)

Reference page #36 in the MRC 7000 Installation, Wiring, Operation Manual, Form 2877, Edition 6, May 1994 update.

To prevent tampering, your programmer comes from the factory with the programming modes turned "OFF".

If adjustment is required then the modes must be turned "ON" before they are accessible. We recommend that when the adjustments have been completed you turn off the programming modes again.

To turn on the mode required perform the following steps:

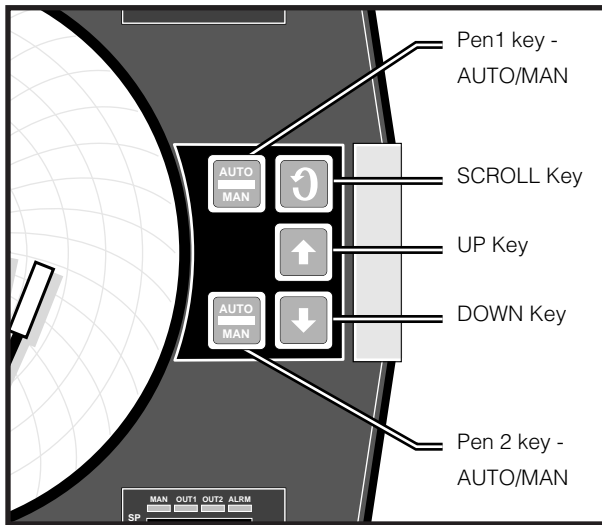

CAL 9900 Controls Drawing

1. Press the scroll key "⤵" until "Ctrl" is displayed.
2. Press and hold the "↑" and "↓" keys at the same time. All the display lamps will light.
3. After 10 seconds the display lights will go out and "EnAb" will be displayed. Release the "↑" and "↓" keys. "EtSt" will appear.
4. Repeatedly press the "↓" key until the desired mode is displayed.
5. Press the scroll key "⤵" once to display the mode's setting ("ON" or "OFF").
6. Press the "↑" key to turn the desired mode "ON".
7. To turn desired mode "OFF" follow steps 1-5 and then press "↓" key.

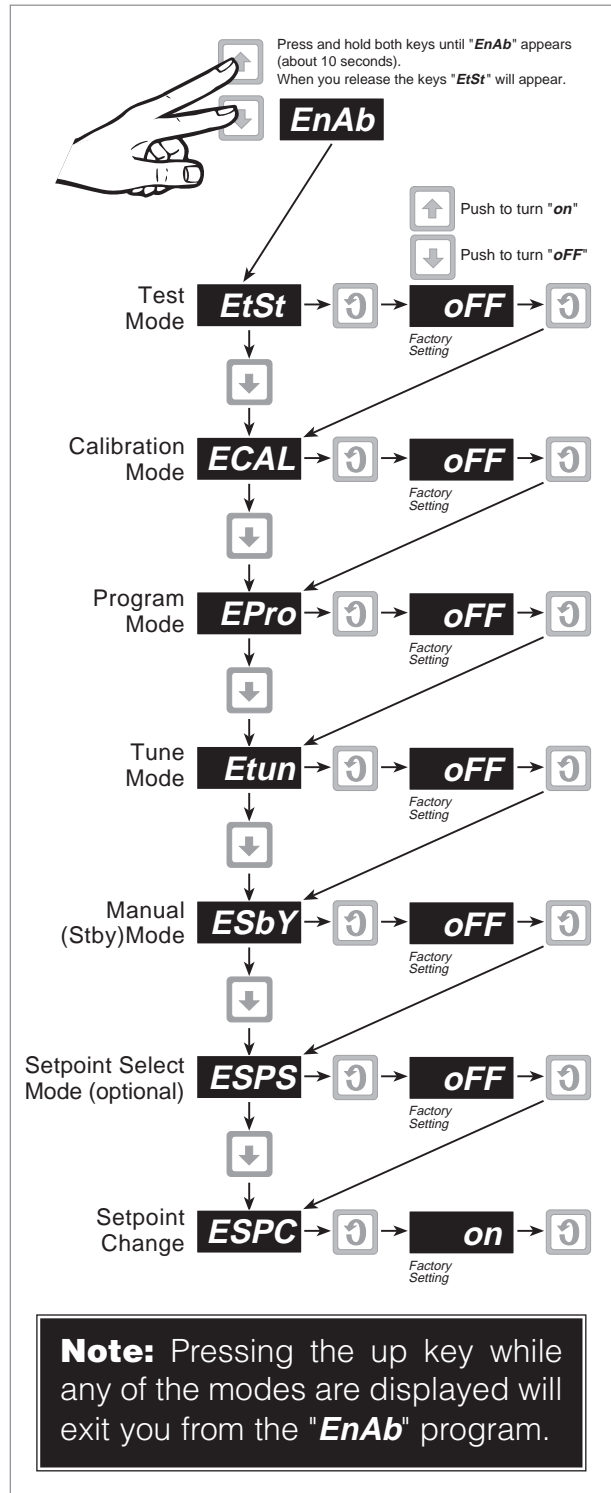

MRC 7000 Enable Mode Flow Chart

MRC 7000 SOFTWARE REFERENCE/RECORD SHEET

Use this sheet to record any changes to the Program, Tune or Enable Modes.

PROGRAM MODE			
	Pen 1	Pen 2	Unit
inPS			rLyA
iCor			rLyb
out1			rLyC
o1ul			rLyd
o1LL			rLyE
out2			rLyF
o2uL			rLyg
o2LL			rLyh
AL1			CurA
AL2			Curb
diSP			CurC
dPoS			Curd
Euu			CoAr
EuL			Cobr
HyCo			CoCr
HyAo			Codr
rSP			Crt
rSPu			Coo
rSPL			CCon
SPuL			CbS
SPLL			CAd1
AtFr			CAd2
Prnd			
dFF			
PFF			
Pout			
Pou			
PoL			
Cru			
CrL			
P1EC			
P2EC			
PAEC			

TUNE MODE		
	Pen 1	Pen 2
SoP		
PAL1		
dAL1		
bAL1		
PAL2		
dAL2		
bAL2		
Pb1		
Pb2		
rSEt		
ArSt		
rAtE		
Ct1		
Ct2		
SEnS		
FoP		

ENABLE MODE	
EtSt	
ECAL	
EPro	
Etun	
ESby	
ESPS	
ESPC	

MRC 7000 GENERAL PROGRAMMING INSTRUCTIONS (1 PEN)

The following instructions are of a general nature. Refer to the MRC 7000 Manual for complete instructions and explanations.

1. Install the chart recorder according to the wiring diagram.
2. Check and change the pin jumpers inside the chart recorder.
3. Set variables in controller by changing parameters in the Program mode (**Prog**) and the Tune mode (**tunE**).
4. Calibrate the pen using the Calibration mode (**CAL**). Use only (**CAL9**).

5. Use the Enable mode (**EnAb**) to turn off the program mode (**EPro**), Calibration mode (**ECAL**), Tune mode (**Etun**), Manual (**Stby**) mode (**Esby**). The off setting means the mode is activated but cannot be accidentally changed.
6. See page 45 (MRC 7000 Installation, Wiring, Operation Manual) - Changing Charts and Changing Pens.

Modes

Use the scroll key to move through the modes until the desired mode is reached. See Key Pad Controls pages 23-24 (MRC 7000 Manual). If the mode required does not show up on the digital display then the Enable mode will have to be accessed and the mode required turned on. See page 36 (MRC 7000 Manual- Enable Mode Configuration Procedure) or page 5 of this manual.

Program Mode (Prog)

Following is a list of the factory settings. A brief description has been provided on items you may wish to change. See page 28-32 (MRC 7000 Manual) for further information.

DISPLAY CODE	FACTORY SETTING	DESCRIPTION
inPS	21	RTD °F
	20	RTD °C
iCor	0	
out1	4	
o1uL	100	
o1LL	0	
out2	3	
o2uL	100	
o2LL	0	
AL1	0	
AL2	0	
diSP	2	display set to read process value and setpoint
dPoS	0	display set to zero decimal position
HyCo	5	Hysteresis band in degrees (glossary pg. 66 - MRC 7000 Manual) - adjust as required
HyAo	10	
SPuL	230	°F setpoint upper limit
	100	°C
SPLL	30	°F setpoint lower limit
	0	°C
AtFr	0	
Prnd	0	process value
dFF	1	
PFF	1	
Pout	0	
Cru	230	°F chart range upper level
	100	°C
CrL	30	°F chart range lower level
	0	°C
P1EC	0	
P2EC	0	
PAEC	1	on error condition, pen goes to 100% of chart
rLyA	5	relay A (heat is assigned to output 1- pen 1)
rLyB	6	relay B (heat is assigned to output 2- pen 1)
CrT	24.0	chart rotation time in hours

Tune Mode (tunE)

Following is a list of the factory settings. A brief description has been provided on items you may wish to change. See page 33-35 (MRC 7000 Manual) for further information.

DISPLAY CODE	FACTORY SETTING	DESCRIPTION
SoP	50	cooling comes on when temperature is exceeded by this amount
Pb1	10	proportional band for output 1, heating
Pb2	10	proportional band for output 2, cooling
rSEt	0	manual reset
ArSt	0	automatic reset
rAtE	0	rate
Ct1	30	cycle time for output 1, heating - DO NOT DECREASE
Ct2	30	cycle time for output 2, heating - DO NOT DECREASE
FoP	0	

Calibration Mode (CAL)

The chart recorder is a sensitive instrument that requires periodic maintenance and recalibration.

Temperature, humidity, vibrations, and handling all contribute to causing errors in temperature reading. Regular inspections a recalibration by a trained service technician with the proper equipment will keep the unit accurate and reliable.

MRC 7000 will calibrate the pen to the chart. This is the only calibration and you can do it without training and equipment. See page 46-49 (MRC 7000 Manual) for instructions.

Enable Mode (EnAb)

The Enable mode allows you to lock out the other modes you do not wish to use or be tampered with. See page 62 (MRC 7000 Manual) for operating instructions.

DISPLAY CODE	FACTORY SETTING	DESCRIPTION
EtSt	oFF	test mode
ECAL	oFF	calibration mode
EPro	oFF	program mode
Etun	oFF	tune mode
ESby	oFF	manual mode
ESPC	on	setpoint change

Jumpers on Process Board

Open the front panel using a screw driver and check the jumpers on the processor board for correct positioning. See page 36 (MRC 7000 Manual) for board layout.

JUMPER	FUNCTION	POSITION
JU1	enable mode	unlocked
JU4	input	T/C, mv, RTD
JU6	RTD input	RTD

MRC 7000 GENERAL PROGRAMMING INSTRUCTIONS (2 PEN)

The following instructions are of a general nature. Refer to the manual for complete instructions and explanations.

1. Install the chart recorder according to the wiring diagram.
2. Check and change the pin jumpers inside the chart recorder.
3. Set variables in controller by changing parameters in the Program mode (**Prog**) and the Tune mode (**tunE**).
4. Calibrate the pen using the Calibration mode (**CAL**). Use only (**CAL9**).

5. Use the Enable mode (**EnAb**) to turn off the Program mode (**EPro**), Calibration mode (**ECAL**), Tune mode (**Etun**), Manual (**Stby**) mode (**Esby**). The off setting means the mode is activated but cannot be accidentally changed.
6. See page 45 (MRC 7000 Installation, Wiring, Operation Manual) - Changing Charts and Changing Pens.

Modes

Use the scroll key to move through the modes until the desired mode is reached. See Key Pad Controls pages 23-24 (MRC 7000 Manual). If the mode required does not show up on the digital display then the Enable mode will have to be accessed and the mode required turned on. See page 36 (MRC 7000 Manual- Enable Mode Configuration Procedure) or page 5 of this manual.

Program Mode (Prog)

Following is a list of the factory settings. A brief description has been provided on items you may wish to change. See page 28-32 (MRC 7000 Manual) for further information.

DISPLAY CODE	FACTORY SETTING PEN 1	FACTORY SETTING PEN 2	DESCRIPTION
iPS	21	21	RTD °F
	20	20	RTD °C
iCor	0	0	Adjust to correct sensor error
out1	1	4	
o1uL	-	100	
o1LL	-	0	
out2	0	3	
o2uL	-	100	
o2LL	-	0	
AL1	0	0	
AL2	0	0	
diSP	2	2	display set to read process value and setpoint
dPoS	0	0	display set to zero decimal position
HyCo	1	5	Hysteresis band in degrees (glossary pg. 66 - MRC 7000 Manual) - adjust as required
HyAo	10	10	
SPuL	250	250	°F setpoint upper limit
	120	120	°C
SPLL	0	0	°F setpoint lower limit
	-10	-10	°C
AtFr	0	0	
Prnd	0	0	process value
dFF	1	1	
PFF	1	1	
Pout	0	0	
Cru	230	230	°F chart range upper level
	100	100	°C
CrL	30	30	°F chart range lower level
	0	0	°C
P1EC	-	0	
P2EC	-	0	
PAEC	1	1	on error condition, pen goes to 100% of chart
rLyA	5	-	relay A (meat probe) is assigned to output 1 - pen 1
rLyB	7	-	relay B (water bath) is assigned to output 2 - pen 2
CrT	24.0	-	chart rotation time in hours
COO	0	-	

Tune Mode (tunE)

Following is a list of the factory settings. A brief description has been provided on items you may wish to change. See page 33-35 (MRC 7000 Manual) for further information.

DISPLAY CODE	FACTORY SETTING	DESCRIPTION
SoP	50	cooling comes on when temperature is exceeded by this amount
Pb1	10	proportional band for output 1, heating
Pb2	10	proportional band for output 2, cooling
rSEt	0	manual reset
ArSt	0	automatic reset
rAtE	0	rate
Ct1	30	cycle time for output 1, heating - DO NOT DECREASE
Ct2	30	cycle time for output 2, heating - DO NOT DECREASE
FoP	0	

Calibration Mode (CAL)

The chart recorder is a sensitive instrument that requires periodic maintenance and recalibration.

Temperature, humidity, vibrations, and handling all contribute to causing errors in temperature reading. Regular inspections a recalibration by a trained service technician with the proper equipment will keep the unit accurate and reliable.

CAL 9 will calibrate the pen to the chart. This is the only calibration and you can do it without training and equipment. See page 46-49 (MRC 7000 Manual) for instructions.

Enable Mode (EnAb)

The Enable mode allows you to lock out the other modes you do not wish to use or be tampered with. See page 36 (MRC 7000 Manual) or page 5 of this manual for operating instructions.

DISPLAY CODE	FACTORY SETTING	DESCRIPTION	AVAILABLE SETTINGS	FACTORY SETTING
EtSt	oFF	test mode	on or oFF	oFF
ECAL	oFF	calibration mode	on or oFF	oFF
EPro	oFF	program mode	on or oFF	oFF
Etun	oFF	tune mode	on or oFF	oFF
ESby	oFF	manual mode	on or oFF	oFF
ESPC	on	setpoint change	on or oFF	on

Jumpers on Process Board

Open the front panel using a screw driver and check the jumpers on the processor board for correct positioning. See page 62 (MRC 7000 Manual) for board layout.

JUMPER	FUNCTION	POSITION
JU1	enable mode	unlocked
JU4	input, pen 1	T/C, mv, RTD
JU5	input, pen 2	T/C, mv, RTD
JU6	RTD input	T/C, mv, RTD
JU7	RTD input	RTD

HORIZONTAL MIXER KETTLES - AC INVERTER PROGRAMMING INSTRUCTIONS

The WFC Series AC Inverters come wired for external use and must be installed for use in a side panel control (See Wiring Diagram.). Refer to owners manual for complete instructions and explanations. Manual used for the following was FORM 1094.

After installation is complete the inverter must be reprogrammed to Cleveland's modifications of the factory settings. All modifications are achieved in Access Level 2.

1. Turn agitator power on. The top four LED indicators will illuminate momentarily - wait for the three green LED's to go out before proceeding.
2. Press the PROGRAM and SHIFT keys simultaneously to reach Access Level 2. The display display will now read:
3. Use the UP/DOWN arrow keys to select the program parameter for change.
4. Press the SHIFT key. The program number will blink indicating that that the data value may be changed.
5. Use the UP/DOWN arrow keys to select the new data code.
6. Press the ENTER key. The display will indicate ****STORED**** for one second, then revert to the normal parameter display.
7. Press the PROGRAM key to exit the programming mode or the UP/DOWN keys to select an new parameter for change.

PROGRAM CODE SUMMARY:

#	Name	Description	Data Range	Factory Setting	Units	Access Level	Customer Setting
01	MODEL	Model Number	0-65000	Note 1	---	1	
02	RVLVL	Software Revision	0-640	Note 1	---	2	
03	IRAT	Rated Current	2-200	Note 1	A	2	
05	SERNO	Serial Number	0-65000	---	---	2	
06	REP	Repair Date	0-65000	---	---	2	
07	FLT3	Last Fault	---	---	---	1	
08	FLT2	2nd Fault	---	---	---	2	
09	FLT1	1st Fault	---	---	---	2	
12	FOUT	Output Frequency	0-400	---	Hz	1	
13	VOUT	Output Voltage	0-100	---	%	1	
14	IOUT	Output Current	0-650	---	A	1	
15	LOAD	Drive Load	0-200	---	%	1	
16	TORQ	Load Torque	0-200	---	%	1	
17	TEMP	Inverter Temp	2-105	---	C	1	
18	TIME1	Total Run Time	0-65000	---	h	2	
19	TIME2	Power On Hours	0-65000	---	h	2	
21	MODE	Input Mode	0-36	0	---	1	4
24	FSEL	Reference Select	0-18	0	---	2	
27	TLSEL	Torque Limit Select	0-6	0	---	2	
31	FMIN	Min. Frequency	0.00-400	0	Hz	1	14
32	FMAX	Max. Frequency	20.00-400	60	Hz	1	70
33	F2	Preset Speed #2 - Jog	0.00-400	5	Hz	1	
34	F3	Preset Speed #3	0.00-400	20	Hz	2	
35	F4	Preset Speed #4	0.00-400	40	Hz	2	
36	F5	Preset Speed #5	0.00-400	60	Hz	2	

Bold areas indicate Cleveland modifications of factory settings.

37	F6	Preset Speed #6	0.00-400	0	Hz	2		
38	F7	Preset Speed #7	0.00-400	0	Hz	2		
39	FTL	Min. Frequency in Torque Limit	0.00-400	10	Hz	2		
41	RSEL	Ramp Selector	0-7	0	---	2		
42	ACC1	Acceleration Time #1	0.10-600	3	s	1	9	
43	DEC1	Deceleration Time #1	0.10-600	3	s	1	1	
44	ACC2	Acceleration Time #2	0.10-600	1	s	2		
45	DEC2	Deceleration Time #2	0.10-600	1	s	2		
46	DECTL	Torq. Limit Response Time	0.10-30	1	s	2		
47	DCBRK	DC Brake Time	0-5	0.2	s	2		
48	DCVLT	DC Brake voltage	0-15	Note1	%	2		
51	VSEL	V/Hz Characteristic Selector 0-5	0-5	0	---	2	2	
52	BOOST	Torque Boost	0-25	Note 1	%	1	8	
53	FKNEE	V/Hz Knee Frequency	26-640	60	Hz	2	75	
54	SKBND	Skip Freq. Hysteresis Band	0.20-20	1	Hz	2		
55	SK1	Skip Frequency #1	0.00-400	0	Hz	2		
56	SK2	Skip Frequency #2	0.00-400	0	Hz	2		
57	SK3	Skip Frequency #3	0.00-400	0	Hz	2		
58	SK4	Skip Frequency #4	0.00-400	0	Hz	2		
59	MVOLT	Rated Motor Voltage	185-480	Note 1	V	2		
61	LTLF	Load Torq. Limit Forward	5-150	150	%	2		
62	LTLR	Load Torq. Limit Reverse	5-150	150	%	2		
63	RTLFL	Regenerative Torq. Limit FWD	5-110	80	%	2		
64	RTLRL	Regenerative Torq. Limit REV	5-110	80	%	2		
65	SLIP	Slip Compensation	0-10*	0	%	1		
66	STAB	Current Stability	0-5	2	---	2		
67	TOL	Timed Overload Trip Point	0-100	0	%	2	100	
68	NRST	Restart Number	0-8	0	---	2		
69	DRST	Restart Delay	0-60*	0	s	2		
6C	TOLC	Timed Overload Characteristic	0-7	0	---	2		
71	METER	Analog Meter Output	0-7	1	---	1		
72	ST1	Auxiliary Output #1	0-11	6	---	2		
73	ST2	Auxiliary Output #2	0-11	3	---	2		
74	ST3	Auxiliary Output #3	0-11	7	---	2		
75	STR	Auxiliary Relay (Fault)	0-11	2	---	2	3	
81	PRGNO	Special Program Number	0-65000	0	---	2	2	
82	START	Inverter Start Options	0-7	0	---	2		
83	PWM	Carrier Frequency Selector	0-1	0	---	2	1	
84	DISP	Display Option Full Setting	0-65000	0	---	2		
85	UNITS	Display Units	ALPHA	RPM_1	---	2		
86	LANG	Display Language	0-3	0	---	2		
87	ACODE	Security Access Code	0-999	0	---	2		
A2	RATIO	Master Slave Speed Ratio (Note 2)	50-2000	100	%	2		
B1	OPTNO	Option Board Number	0-6	0	---	2		
Cx	CNTLx	Event Control (1-9)	BINARY (8)	0	---	2		
Ex	ECNTx	Event Counts (1-9)	0-65535	0	---	2		

Bold areas indicate Cleveland modifications of factory settings.