

E-Series prefilters are designed to increase the life of Everpure carbon water filters in areas with an unusual amount of dirt in the water. With a 10 micron (nominal) rating, the Everpure prefilter traps much of the dirt which contributes to scale buildup in ice makers, and clogs the delicate orifices of other water-using equipment.

PARTS LIST

Description	Part No.
Head	EV3112-37
O-Ring (E-Series)	EV3112-40
EC110 Coarse Prefilter Cartridge 40 pk.	EV9534-40
EC110 Coarse Prefilter Cartridge 12 pk.	EV9534-12
EC210 Coarse Prefilter Cartridge 20 pk.	EV9534-20
EC210 Coarse Prefilter Cartridge 6 pk.	EV9534-26
10" Bowl, clear	EV3112-39
20" Bowl, clear	EV3112-38
10" Bowl, opaque	EV3112-56
20" Bowl, opaque	EV3112-55
Reducer Bushing for inlet and outlet ports 3/4" NPT x 3/8" FPT (E10)	EV3105-91
Reducer Bushing for inlet and outlet ports 3/4" NPT x 1/2" FPT (E20)	EV3098-23
Filter wrench	EV3112-41

*The Standard EC110 Cartridge is provided with each Model E10 Filter. It is rated at 10 microns nominally and has a more-than-adequate life when filtering water with "normal" or average dirt loads. The EC210 cartridge is provided with each E20 filter, which is also rated at 10 microns nominally.

APPLICATIONS AND FEATURES

- General purpose coarse filtration
- Pre-filtration for fine filters
- Reduces dirt, rust, oxidized iron and sulfide
- High-strength materials

INSTALLATION

The E10 coarse prefilter (part number EV9795-80) includes two 3/8" FPT optional reducer bushings. The E20 coarse prefilter (part number EV9795-90) includes two 1/2" FPT optional reducer bushings. Before starting the installation, be sure to shut off both power and water to the equipment being served by your E-Series prefilter. For servicing purposes, a manual shut-off valve should be installed in the water line.

IMPORTANT: Always use a NSF approved pipe dope or Teflon tape at all thread connections.

1. Select a suitable location for mounting the prefilter and install mounting screws 2 1/4" apart. The prefilter should be close to the machine served and mounted ahead of the carbon filters for optimum performance.
2. Remove the prefilter from the carton and separate the bowl and head assembly. Set the bowl and cartridge aside. If installing the EV9795-80 coarse filter, assemble (2) 3/8" FPT x 3/4" MPT bushings to the head (as needed). If installing the EV9795-90 coarse filter, assemble (2) 3/4" MPT x 1/2" FPT bushings to the head (as needed). Be sure to use a NSF approved pipe dope or teflon tape.
3. Check to be sure the o-ring on the bowl is sufficiently lubricated. If additional lubrication is needed, use only a high quality food grade silicone lubricant.
4. Position the cartridge on the guide seat in the bottom of the bowl. Then screw the bowl onto the head, by hand; snug with filter wrench (EV3112-41)



E10 Prefilter—EV9795-80



E20 Prefilter—EV9795-90

INSTALLATION (continued)

5. Connect the water line to the inlet of the prefilter. (Use 3/8" minimum piping on Coarse prefilter EV9795-80, use 1/2" minimum piping on EV9795-90). Connect outlet side to the next piece of equipment used.
6. If installing the E-Series prefilter for use with standard Everpure Quick Change filters, shut off the water supply to the carbon filters by rotating the valve handles on the heads, to approximately the 9 o'clock position. If the E-Series prefilter is being installed to provide protection to an Everpure High Flow CSR water treatment system, shut off main water supply, install the prefilter in front of the ball valve and an additional ball valve in front of the prefilter.
7. Turn on the water to the prefilter and press the red button on the head to open the pressure relief valve, purging air from the system. When water begins coming through the pressure relief valve, release the button. Inspect the filter assembly for leaks.

Your prefilter is now in service, prolonging the life of the carbon filters. Always keep a supply of replacement cartridges on hand.

CARTRIDGE CHANGE

Replace prefilter cartridges when dirt has penetrated the center core of the cartridge or when the pressure gauge after the prefilter indicates extremely low pressure during water flow.

1. Turn off inlet water valve and press the pressure relief valve.
2. Unscrew the bowl from the filter head, remove the used cartridge and empty the water from the bowl.
3. If the o-ring on the bowl feels dry, lubricate it with a high quality food grade silicone lubricant.
4. Clean the bowl with a mild solution of unscented dishwashing detergent. DO NOT use soap, strong or scented detergents, chemical cleansers or abrasives.
5. Position the replacement cartridge on the guide seat in the bottom of the bowl. Then firmly screw the bowl into the head by hand. Snug with filter wrench (EV3112-41).

FILTER SPECIFICATIONS

Head has 3/4" female pipe threads for inlet and outlet pipe connections: it is constructed of polypropylene. The clear bowls are constructed of transparent plastic for easy visual inspection. The opaque bowls are constructed of polypropylene. Dirt/Rust cartridges are graded density spool type, with synthetic materials.

Protect filter bowl from pesticide sprays.

	E10 Prefilter	E20 Prefilter
Flow rate:	4 gpm (15 lpm) recommended	8 gpm (30.3 lpm) recommended
Capacity:	variable, depending on local water quality	variable, depending on local water quality
Pressure:	10-125 psig (0.3 - 8.6 bar), non-shock	10-125 psig (0.3 - 8.6 bar), non-shock
Temperature:	35-100°F (2-38°C)	35-100°F (2-38°C)
Unit dimensions:	5.16" x 12.44 (13.1 x 31.6 cm)	5.16" x 22.44" (13.1 x 57 cm)
	<i>a clearance of 2" (5 cm) underneath is required for cartridge exchange</i>	
Cartridge length:	EC110, 9.75" (25 cm)	EC210, 20" (50.7 cm)
Connections:	3/4" internal pipe thread (FPT)	3/4" internal pipe thread (FPT)

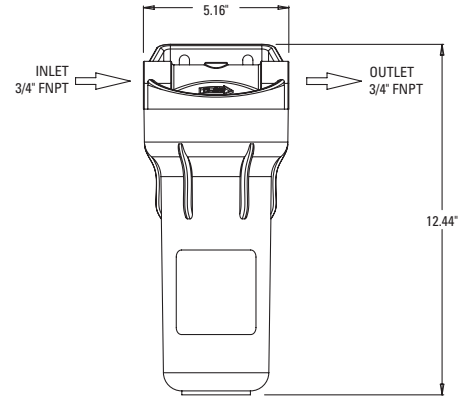

Figure 4 – E10 Prefilter – EV9795-80

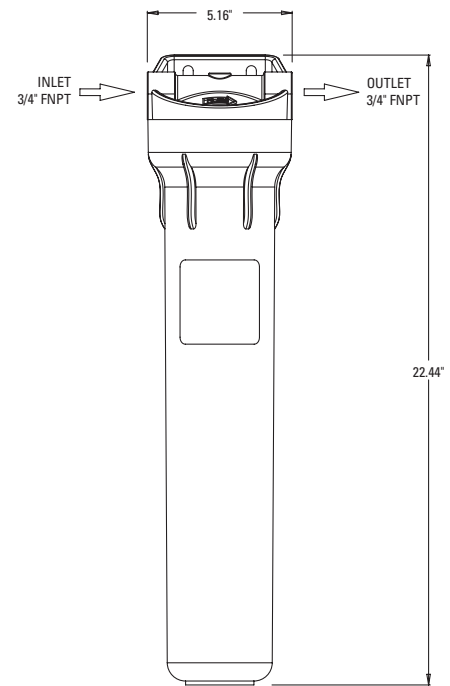

Figure 5 – E20 Prefilter – EV9795-90

LIMITED WARRANTY

COMMERCIAL WATER TREATMENT EQUIPMENT

You have just purchased one of the finest water treatment units made. As an expression of our confidence in Everpure products, this product is warranted against defects in material and workmanship to the original end-user when installed in accordance with Everpure specifications. The warranty period commences from the date of purchase and is administered as follows:

For a period of ONE YEAR

Replaceable elements (i.e., filter & water treatment cartridges)*

For a period of FIVE YEARS

The entire system (excluding replaceable elements)

***This is for material & workmanship, not filter or water treatment cartridge life.**

The unit must be used in operating conditions that conform to Everpure's recommended design guidelines. This warranty will not apply if the unit has been modified, repaired or altered by someone not authorized by Everpure.

If a part described above is found defective within the specified period, you should notify Everpure technical service at the phone number listed below. Any part found defective within the terms of this warranty will be repaired or replaced (at Everpure's discretion) by your local dealer or Everpure technical service. You pay only freight from our factory and local dealer charges. Any repaired or replaced warranty item will be incorporated under the original warranty terms of the existing system.

We are not responsible for damage caused by accident, fire, flood, freezing, Act of God, misuse, misapplication, neglect, oxidizing agents (such as chlorine, ozone, chloramines and other related components), alteration, installation or operation contrary to our printed instructions, or by the use of accessories or components which do not meet Everpure's specifications. Refer to the specifications section in the Installation and Operating manual for approved application parameters.

Our product performance specifications are furnished with each water treatment unit. TO THE EXTENT PERMITTED BY LAW, EVERPURE DISCLAIMS ALL IMPLIED WARRANTIES, INCLUDING WITHOUT LIMITATION WARRANTIES OF MERCHANTABILITY AND FITNESS FOR PARTICULAR PURPOSE; TO THE EXTENT REQUIRED BY LAW, ANY SUCH IMPLIED WARRANTIES ARE LIMITED IN DURATION TO THE PERIOD SPECIFIED ABOVE FOR THE ENTIRE WATER TREATMENT UNIT. As a manufacturer, we do not know the characteristics of your water supply or the purpose for which you are purchasing this product. The quality of water supplies may vary seasonally or over a period of time, and your water usage rate may vary as well. Water characteristics can also differ considerably if this product is moved to a new location. For these reasons, we assume no liability for the determination of the proper equipment necessary to meet your requirements, and we do not authorize others to assume such obligations for us. Further, we assume no liability and extend no warranties, express or implied, for the use of this product with a non-potable water source or a water source which does not meet the conditions for use described in the owner's guide or performance data sheet for this product. OUR OBLIGATIONS UNDER THIS WARRANTY ARE LIMITED TO THE REPAIR OR REPLACEMENT (AT EVERPURE'S DISCRETION) OF THE FAILED PARTS OF THE WATER TREATMENT UNIT, AND WE ASSUME NO LIABILITY WHATSOEVER FOR DIRECT, INDIRECT, INCIDENTAL, CONSEQUENTIAL, SPECIAL, GENERAL OR OTHER DAMAGES.

Some states do not allow the exclusion of implied warranties or limitations on how long an implied warranty lasts, so the above limitation may not apply to you. Similarly, some states do not allow the exclusion of incidental or consequential damages, so the above limitation or exclusion may not apply to you. This warranty gives you specific legal rights, and you may also have other rights which vary from state to state. Consult your telephone directory for your local independently operated Everpure dealer, or write Everpure for warranty and service information.



For sales, replacement components, and service, contact your Everpure dealer or:

Everpure, LLC: 1040 Muirfield Drive • Hanover Park, Illinois 60133 • 800.323.7873

In Europe: Toekomstlaan 30 • B-2200 Herentals, Belgium

In Japan: Hashimoto MN Bldg. 7F • 3-25-1 Hashimoto Sagamihara-Shi • Kanagawa 229-1103, Japan

Technical Service
800.942.1153
www.everpure.com