

2 OR 3 COMPARTMENTS
DIRECT STEAM, OPEN STAND
PEDESTAL BASE OR WALL MOUNTED

Project _____
Item _____
Quantity _____
FCSI Section 11400 _____
Approved _____
Date _____

Models

- 2 Compartments
- PDL-2
- 3 Compartments
- PDL-3



Standard Features

- 5 psi Operating Pressure in cooking compartments
- Mechanical interlock prevents unlatching door while compartment is pressurized
- Timers, one per compartment, are mechanical style with audible signal
- Thermostatic Trap vents cooking compartment automatically
- Steam Inlet Valves and Exhaust Valves interlocked for synchronous action
- 8 psi Compartment Safety Valve
- Capacity per compartment for eight, 12" x 20" x 2 1/2" deep Cafeteria Pans, or four, 18" x 26" Bun Pans
- Heavy Duty, free floating, cast aluminum compartment doors
- Compartment Door Hinges have adjustable hinge pins and self-lubricating bushings
- Door Gasket replaceable without tools
- Pressure Gauge for compartment Operating Pressure
- Compartment Slide Racks are removable without tools, for easy cleaning
- Type 430 Stainless Steel: external enclosure, Table Top and eight gauge plate cooking compartments
- Moisture Separator for incoming steam
- Pressure Reducing Valve for 12 to 50 psi steam supply pressure
- 6" Adjustable Legs with flanged feet

Short Form Specifications

Shall be _____ Compartments, CLEVELAND, Pressure Steamer, Model PD- _____ - _____, for Direct Steam operation,; _____ volts, single phase. Each Cooking Compartment equipped with: 60 Minute Timer; Pressure Safety Valve; Heavy-duty, free floating Door with Safety Interlock; and synchronous operating Steam Inlet and Exhaust/Drain Valves. Compartments are mounted to a Low Cabinet type base or Wall Mounted

Options & Accessories

- Second Pressure Reducing Valve for 50 to 120 psi supply pressure (PRV)
- Special Compartment Slide Racks
- 12" x 20" Cafeteria Pans 1", 2 1/2", 4" or 6" deep
- Intermediate Pull-Out Shelf (POS)

Note: Clean, non toxic, uncontaminated steam is required for all "Direct Steam" steamers

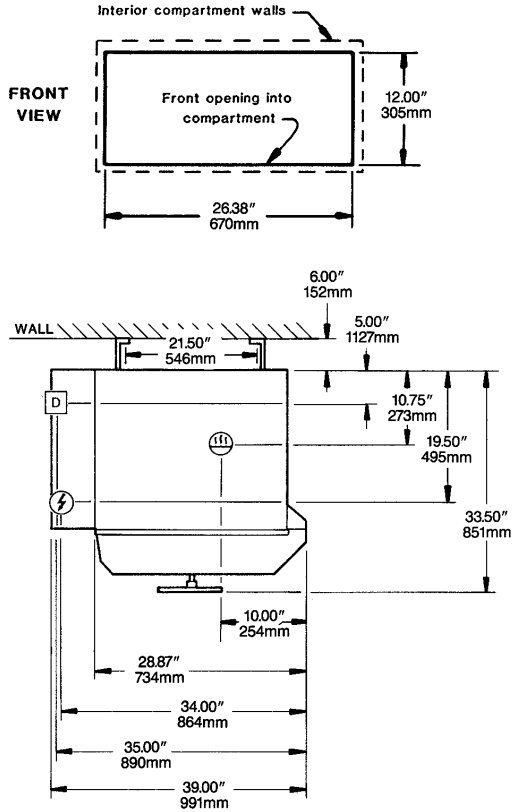
COMPARTMENT HAS CAPACITY FOR:

Eight, 12" x 20" x 2 1/2"	Cafeteria Pans or
Six, 12" x 20" x 4"	Cafeteria Pans or
Four, 12" x 20" x 6"	Cafeteria Pans or
Four, 18" x 26"	Bun Pans

**WATER QUALITY REQUIREMENTS
(Boilers, Generators)**

TTDS:	50-250 ppm
Hardness:	50 - 200 mm (3 - 12 gpg)
pH value:	7.0 - 8.5
CL (Chloride):	max 50 ppm
Cl ₂ (free chlorine):	max 0.1 ppm
SiO ₂ (silica):	max 13 ppm
NH ₂ Cl: (mono-chloramine)	max 0.1 ppm
Total Alkalinity:	50 - 100 ppm
Water Pressure	35 - 80 PSI
Temperature:	max 104°F

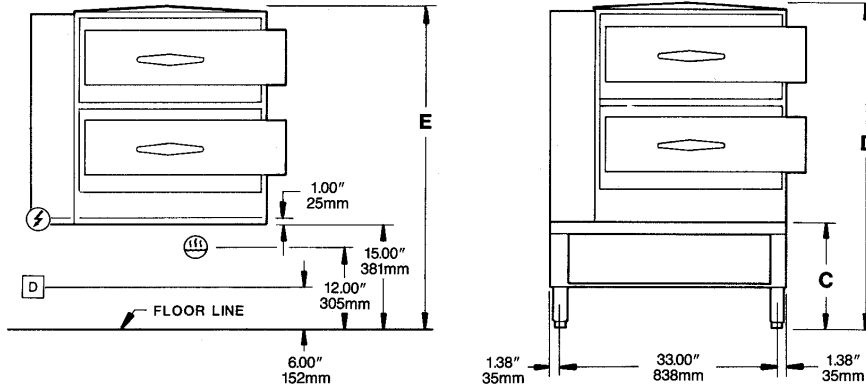

STEAM	ELECTRIC	DRAINAGE	CLEARANCE
Steam supply piping: • 3/4" IPS minimum line. 12 to 45 psi required. • For pressures above 45 to 120 psi, an additional Pressure Reducing Valve must be specified.	115V-1 Phase Units with Auto Timers use 25 watts per compartment		

	A	B	C	D	E
2 Compartments	IN 23.44	57.06	22.00	55.63	48.00
	mm 595	1449	559	1412	1219
3 Compartments	IN 19.44	63.06	18.00	61.63	59.00
	mm 494	1602	457	1565	1499

NOTES:

**DO NOT CONNECT TO GFI OUTLET. CLEVELAND RANGE RECOMMENDS GAS FIRED 120 VOLT STEAMERS BE HARD WIRED DIRECTLY TO ELECTRICAL SYSTEM. Cleveland Range reserves right of design improvement or modification, as warranted. Many regional, state and local codes exist and it is the responsibility of the owner and installer to comply with the codes. Cleveland Range equipment is built to comply with applicable standards for manufacturers. Included among those approval agencies are ASME/N. Bd, NSF and CSA (AGA, CGA). Cleveland Range reserves right of design improvement or modification, as warranted.

(NOT TO SCALE)