

MIXER KETTLE, ELECTRIC TABLE TYPE, TILTING 2/3 JACKETED

Project _____
 Item _____
 Quantity _____
 FCSI Section 11400 _____
 Approved _____
 Date _____

Models

- MKET-12-T



Shown with optional Faucet

Standard Features

- Solid State temperature Control ($\pm 1^\circ\text{F}$) for perfect simmering
- Solid State Low Water Safety Control
- Steam jacket filled with treated water, venting and/or refilling is not required
- 50 psi safety valve mounted under kettle to avoid tampering
- No water gauge required
- Rear mounted Pressure/Vacuum Gauge and Pressure Relief Valve protected by Stainless Steel Bracket
- Infinitely variable speed for all conditions; scraper from 0-70 rpm, agitator from 0-210 rpm
- Removable (without tools) Nylon Blades scrape entire jacketed surface
- 3/4 horse power D.C. Timing Belt Drive
- Safety Device prevents High Speed Starts
- Mixing stops when bridge is lifted - includes safety cover and screen
- Agitator and Scraper are bayonet mounted for easy removal
- Enclosed, balanced, 10 Gauge Stainless Steel Mixer Bridge
- Kettle and all exterior surfaces are Stainless Steel
- Large Pouring Lip
- Gallon Markers on Scraper Shaft
- Standard is 208-240 volts, 60 Hz, 3 phase
- Typical approvals include UL, CSA, CE, NSF and ASME

Short Form Specifications

Shall be CLEVELAND, Model MKET-12-T, Table Type Tilting, 12 Gallon, Electric Mixer Kettle with permanently filled steam jacket, 50 psi jacket rating and safety valve, Solid State Temperature ($\pm 1^\circ\text{F}$) and Low Water Safety Controls, rear mounted Combination Pressure/Vacuum Gauge, infinitely variable speed, 3/4 H.P. Timing Belt Drive, bayonet mounted Agitator and Scraper with removable blades, safety device prevents high speed starts, mixing stops when bridge is lifted. Kettle and all exterior surfaces are Stainless Steel.

Options & Accessories

- Double or Single Pantry Faucet (DPK or SPK)
- Faucet Bracket (FBKT)
- Food Strainer (FS-12)
- Flow Diverter (F-D)
- Kettle Accessory Kit (KAK) includes:
 - Clean-up Brush (CB)
 - 36" Kettle Paddle (KP)
 - 36" Kettle Whip (KW)
 - 36" Kettle Brush (KB)
 - Draw-off Brush (DB)
 - 24 oz. Ladle (KL)
- Type 316 Stainless Steel Kettle Interior for high acid food products (316-12G)
- Water Meter (GMF or LMF) Wall Mounted or on Stand (SWM)
- High Wattages (HW) and Special Voltages (VOS)

KE004046-81

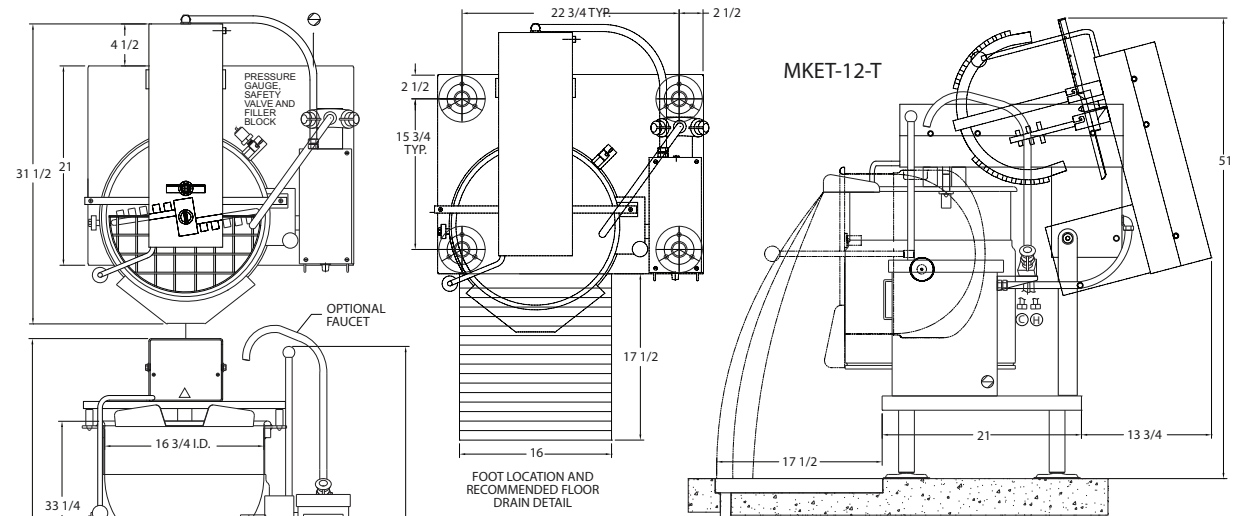
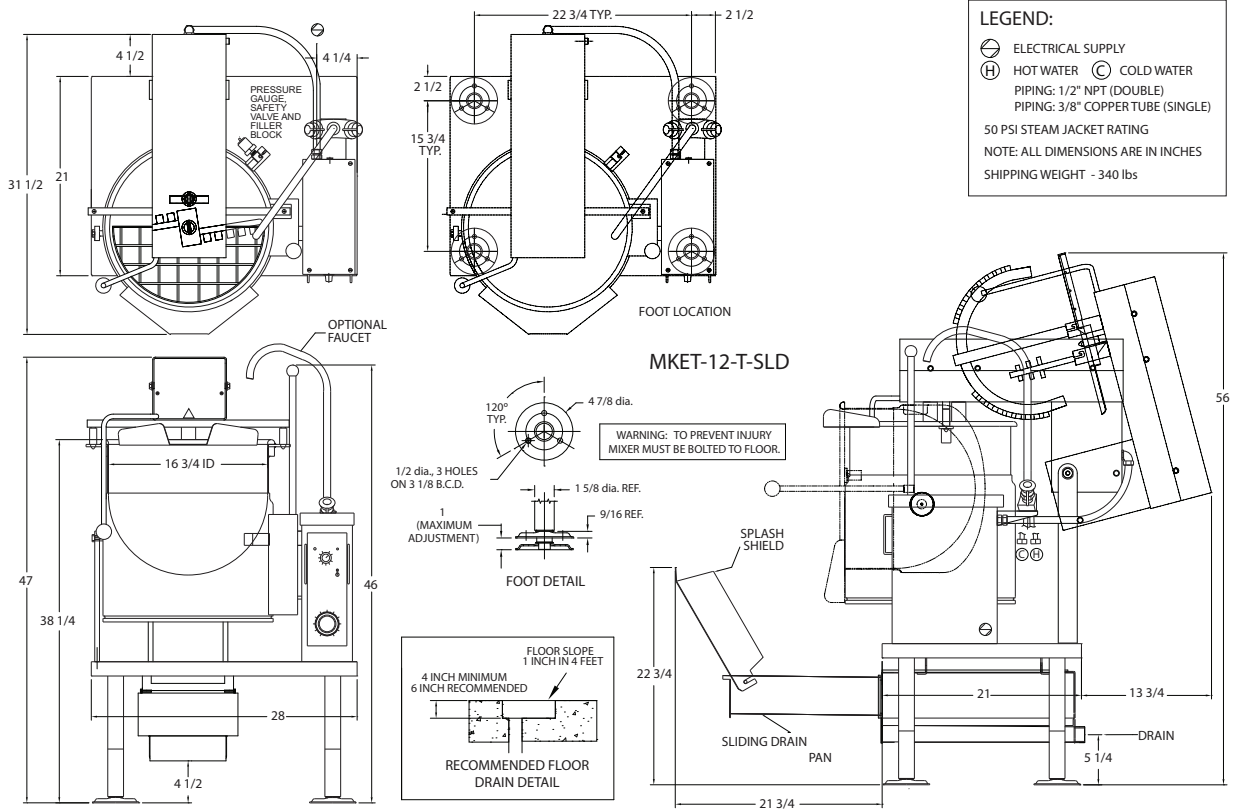

STANDARD WATTAGE

GALS.	LITERS	208V		240V		415V		480V					
		KW	AMPS	KW	AMPS	KW	AMPS	KW	AMPS				
12	45	9.8	47.2	27.2	13.1	54.4	31.4	12.1	29.0	16.7	13.1	27.2	15.7

HIGH WATTAGE

GALS.	LITERS	208V		240V		415V		480V					
		KW	AMPS	KW	AMPS	KW	AMPS	KW	AMPS				
12	45	12.3	59.0	34.1	16.3	68.1	39.3	15.1	36.2	20.9	16.3	34.0	19.6

Consult factory for other voltages.

NOTES:

Cleveland Range reserves right of design improvement or modification, as warranted.
 Many regional, state and local codes exist and it is the responsibility of the owner and installer to comply with the codes.
 Installation of backflow preventers, vacuum breakers and other specific code requirements is the responsibility of the owner and installer.
 Cleveland Range equipment is built to comply with applicable standards for manufacturers. Included among those approval agencies are U.L., A.G.A., NSF, ASME/N.Bd., CSA, CGA, ETL and others.

(NOT TO SCALE)