

**ONE AND TWO PEN 12 INCH CIRCULAR CHART RECORDERS AND  
RECORDING CONTROLLERS**

# MRC 8000

Installation, Wiring, Operation Manual

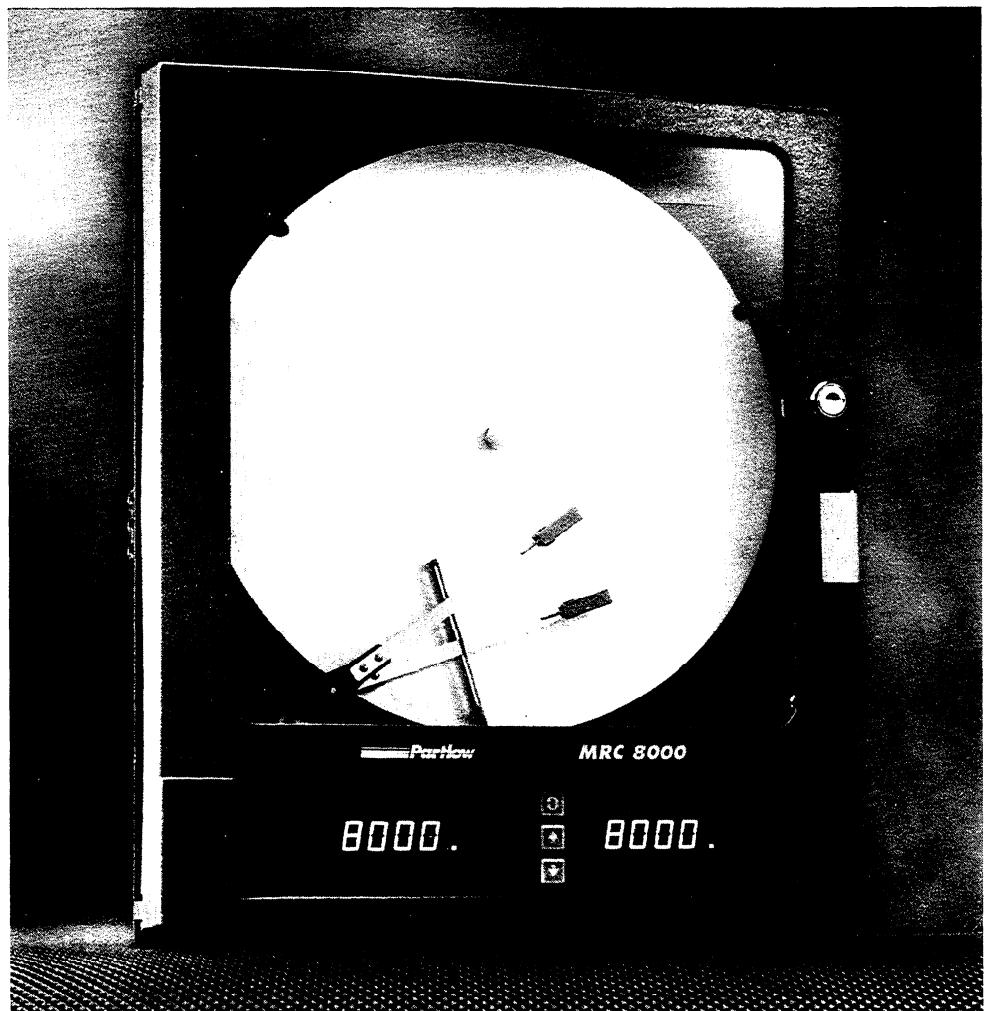

---

---

**Partlow**  
The Partlow Corporation • Two Campion Rd. • New Hartford, NY 13413 USA • 315-797-2222 • FAX 315-797-0403  
**QUALITY INSTRUMENTATION DESIGNED & MANUFACTURED IN THE USA**

---

**I**nformation in this installation, wiring, and operation manual is subject to change without notice. One manual is provided with each instrument at the time of shipment. Extra copies are available at the price published on the front cover.

Copyright © June 1997, The Partlow Corporation, all rights reserved. No part of this publication may be reproduced, transmitted, transcribed or stored in a retrieval system, or translated into any language in any form by any means without the written permission of the Partlow Corporation.

This is the First Edition of the MRC 8000 Recording Controller Manual. It was written and produced entirely on a desk-top-publishing system. Disk versions are available by written request to the Partlow Advertising and Publications Department.

We are glad you decided to open this manual. It is written so that you can take full advantage of the features of your new MRC 8000 microbased chart recording controller.

---

## ***NOTE***

***It is strongly recommended that Partlow equipped applications incorporate a high or low limit protective device which will shut down the equipment at a preset process condition in order to preclude possible damage to property or products.***

---

# TABLE OF CONTENTS

<b>SECTION 1 - GENERAL</b>	<b>PAGE NUMBER</b>
1.1 Product Description	5
<b>SECTION 2 - INSTALLATION &amp; WIRING</b>	
2.1 Installation & Wiring	8
2.2 Unpacking	8
2.3 Location	8
2.4 Mounting	8
2.5 Preparation for Wiring	10
2.6 Wiring Connections	14
<b>SECTION 3 - CONFIGURATION</b>	
3.1 Configuration (Set Up)	20
3.2 Configuration/Jumper Positioning	21
3.3 Operation Summary	21
3.4 Start Up Procedures	22
3.5 Front Panel Operation	22
<b>SECTION 4 - OPERATION</b>	
4.1 Off Control Mode	39
4.2 Alarm Operation	43
4.3 Tune Mode Operation	44
<b>SECTION 5 - SERVICE</b>	
5.1 Service	47
5.2 Changing Charts	47
5.3 Changing Pens	47
5.4 Calibration	48
5.5 Test Mode Procedures	53
5.6 Troubleshooting and Diagnostics (Error Code Definitions)	57
<b>APPENDICES</b>	
A - Board Layouts and Jumper Positioning	
A-1 - Processor Board	64
A-2 SPST Relay/SSR Driver Output Board	65
A-3 Current Output Board	66
B - Glossary	67
C- Order Matrix	69
D- Product Specifications	70
E- Software Record/Reference Sheet	73
Warranty	75

---

## FIGURES & TABLES

Figure 1-1	Recorder Description	5
Figure 1-2	Recorder Display	7
Figure 2-1	Installation Panel Dimensions Conduit Opening Locations	9
Figure 2-2	Noise Suppression	11
Figure 2-3	Noise Suppression	11
Figure 2-4	Board and Terminal Locations	14
Figure 2-5	AC Power Input	15
Figure 2-6	Thermocouple Inputs	15
Figure 2-7	RTD Inputs	15
Figure 2-8	Milliamp, Volt and Millivolt Inputs	16
Figure 2-9	Remote Setpoint Input VDC, mADC	16
Figure 2-10	Digital Communications	17
Figure 2-11A	SPST Relay Output	17
Figure 2-12	SSR Output	18
Figure 2-13	Current Output	18
Figure 2-14	24 VDC Power Supply Option	19
Figure 2-15	Position Proportioning Control Output	19
Figure 3-1	Keypad Features	24
Figure 5-1	Changing Pens	47
Table 3-1	Program Mode Configuration Procedure	28
Table 3-2	Tune Mode Configuration Procedure	35
Table 3-3	Enable Mode Configuration Procedure	37
Table 5-1	Calibration Procedure	49
Table 5-2	Test Procedures and Description	54

---

## FLOW CHARTS

Flow - Alarm Set Mode	33
Flow - Calibration	48
Flow - Enable Mode	38
Flow - Program Mode	25
Flow - Setpoint Select	40
Flow - Standby	43
Flow - Test	53
Flow - Tune Mode	34

---

# Product Description 1.1

---

## 1.1.1 GENERAL

The instrument is a microprocessor based circular chart Recorder or Recording Controller capable of measuring, displaying, recording and controlling from a variety of inputs. Applications include temperature, level, pressure, flow and others. The instruments can be specified as either a single or as a dual pen model.

Recording, control functions, alarm settings and other parameters are easily entered via the keypad. All user's data can be protected from unauthorized changes by the Enable mode security system, and is protected against memory loss, as a result of AC power outage, by battery back-up.

The process sensor input for each pen is user configurable to directly connect to either thermocouple, RTD, mVDC, VDC, or mADC inputs. Changes in input type can easily be made by the user. Thermocouple and RTD linearization, as well as thermocouple cold junction compensation, are performed automatically. The instrument process variable inputs are isolated. An isolated 24 VDC regulated transmitter power supply can be provided in the instrument for use with up to two 4 to 20 mADC process sensor transducers.

The instrument can be ordered to operate on either 115 VAC or 230 VAC power at 50/60 Hz. The 230 VAC option includes a switch for selecting either 230 VAC or 115 VAC operation. The instrument is housed in a structural foam enclosure suitable for panel or surface mounting.

---

**FIGURE 1-1**



*The number of keys and LED's will depend upon the configuration of individual unit.*

---

### **1.1.2 RECORDING**

The instrument records the selected process variable on a 12-inch circular chart. One box of standard charts is provided with each recorder. Charts are available in a wide selection of ranges. Chart rotation speed is programmable from 0.1 to 999.9 hours per revolution in 0.1 hour increments. The instrument can be ordered with one or two pens. Pen 1 is red and Pen 2 is green. Pens are the disposable fiber-tip type.

---

### **1.1.3 DISPLAYS**

Each instrument has a digital display and status indicators for each pen (See Figure 1-1, page 5). On Recording Controllers, the display may be configured to display the Process Value, Process Value and Setpoint, Deviation from Setpoint only, Deviation and Setpoint, or Setpoint only. During configuration the display(s) is/are used to show the enabled modes of operation and the parameter codes.

The display at the left is for Pen 1, the display at the right is for Pen 2 (if provided). On Recorders, the display includes status indicators for Alarm 1 and Alarm 2, degrees C, degrees F, engineering units, and setpoint (for limits). On Recording Controllers, the display includes status indicators for Manual mode operation, Output 1, Output 2, Alarm, degrees C, degrees F, engineering units, setpoint and minus sign. See Figure 1-2 (page 7).

Display resolution is programmable for 0.1 or 1 degree for thermocouple and RTD inputs, and none, one, two or three decimal places for other input types.

---

### **1.1.4 CONTROL**

The instrument can be provided with relay, solid state relay driver and milliamp DC outputs. Instruments can be programmed for on-off, time proportioning, current proportioning or position proportioning control depending upon the hardware present. Switching between the Control mode and the Manual mode of operation is easily accomplished with a dedicated key on the keypad. Switching is bumpless from the Control to the Manual mode, and while in manual, manipulation of proportional outputs is possible. Each pen of a dual pen recording controller is provided with its own AUTO/MANUAL key. Other standard control features include proportional control output limits, setpoint limits, anti-reset windup and a unique Automatic Transfer function. If configured, the Automatic Transfer function allows manual control of the proportional output until the process reaches the setpoint at which time the instrument will go into the Control (automatic) mode of operation.

---

### **1.1.5 ALARM**

An Alarm indicator is standard for each pen. Two alarm functions are provided for each pen and the alarm indicator will light if either alarm for that pen is on. Alarm settings are programmable. Alarm type may be selected as process direct or reverse (high or low), deviation from setpoint direct or reverse, and deviation band open or closed within the band. Alarm outputs can be provided by assigning any relay(s) Single Pole/Single Throw (SPST) or Solid State Relay (SSR) driver to the respective alarm.

---

### **1.1.6 PROCESS VALUE RE-TRANSMISSION OUTPUT**

If an instrument is specified with mA DC current output(s), any of the outputs may be programmed to operate as a process value re-transmission output. The output is scaleable but can not be used as a control output while assigned as a process value re-transmission output.

### 1.1.7 DIGITAL COMMUNICATIONS

The instrument can be ordered with a Digital Communications option that provides the capability of bi-directional communications with a supervisory computer. A dual pen instrument can have an individual address selected for each pen. Refer to the Communications Protocol Manual (Form 2878) for more details regarding the communications option. This manual is included with the unit when the communications option is specified.

**FIGURE 1-2**

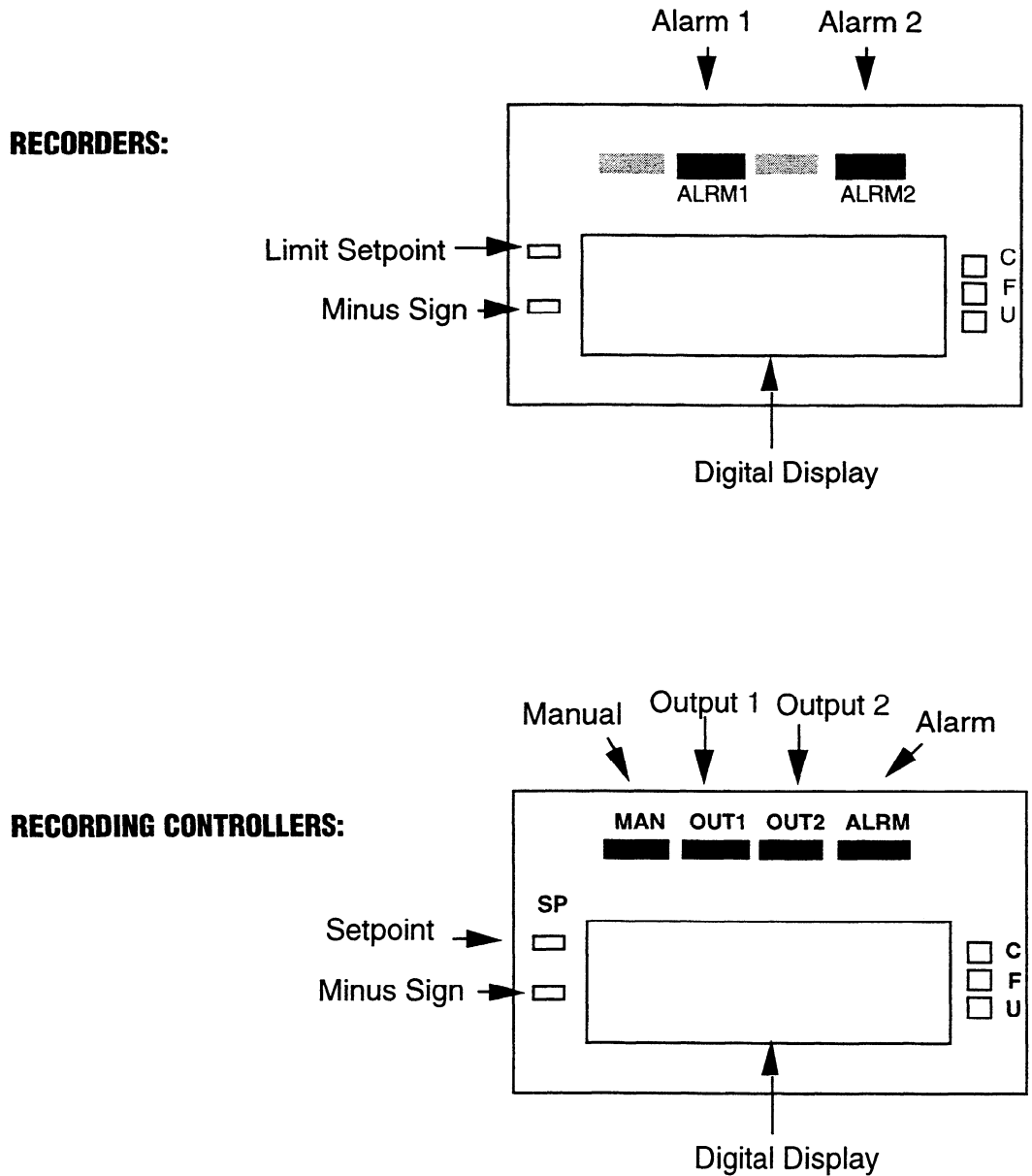

---

## Installation and Wiring 2.1

Read these instructions carefully before proceeding with installation and operation. Electrical code requirements and safety standards should be observed. Installation should be performed by qualified personnel.

**CAUTION: The instrument AC power input is specified in the model number and on the wiring label affixed to the top center of the platen. Verify the AC power input required by the instrument prior to proceeding with installation.**

---

## Unpacking 2.2

Remove the instrument from the carton and inspect for any damage due to shipment. If any damage is noticed due to transit, report and file a claim with the carrier. Write the model number and serial number of the instrument on the inside of the front cover of this Operation Manual for future reference.

---

## Location 2.3

Locate the instrument away from excessive moisture, oil, dust, and vibration. Do not subject the instrument to operating temperatures outside of the 32°F to 131°F (0°C to 55°C) range.

---

## Mounting 2.4

Figure 2-1A and 2-1B (below and page 2) shows an installation view and physical dimensions for a panel mounted instrument. The panel where the instrument will be mounted must provide rigid support for the approximately 25 pound instrument. Adjacent instruments may be mounted within a minimum of 2 inches horizontally and 1 inch vertically, providing that proper panel support is supplied.

Panel Mounting Hardware Required: (not provided with instrument)

- (4) #10 flat head bolts with nuts
- (4) lock washers

### Panel Mounting

1. Cut panel opening to the dimensions illustrated in Figure 2-1A (below).
2. Pre-drill four 3/16 dia. holes for mounting or use the drill template molded into the case after inserting the instrument into the panel.
3. Insert the instrument in the panel opening. Firmly fasten the instrument to the panel using the nuts, bolts and lock washers.

### Surface Mounting

Install the mounting brackets, ordered separately, on the vertical sides of instrument housing. Use the brackets to fasten the instrument to the surface. Hardware recommended - #10-24 SCRs.

**FIGURE 2-1**

Figure 2-1A

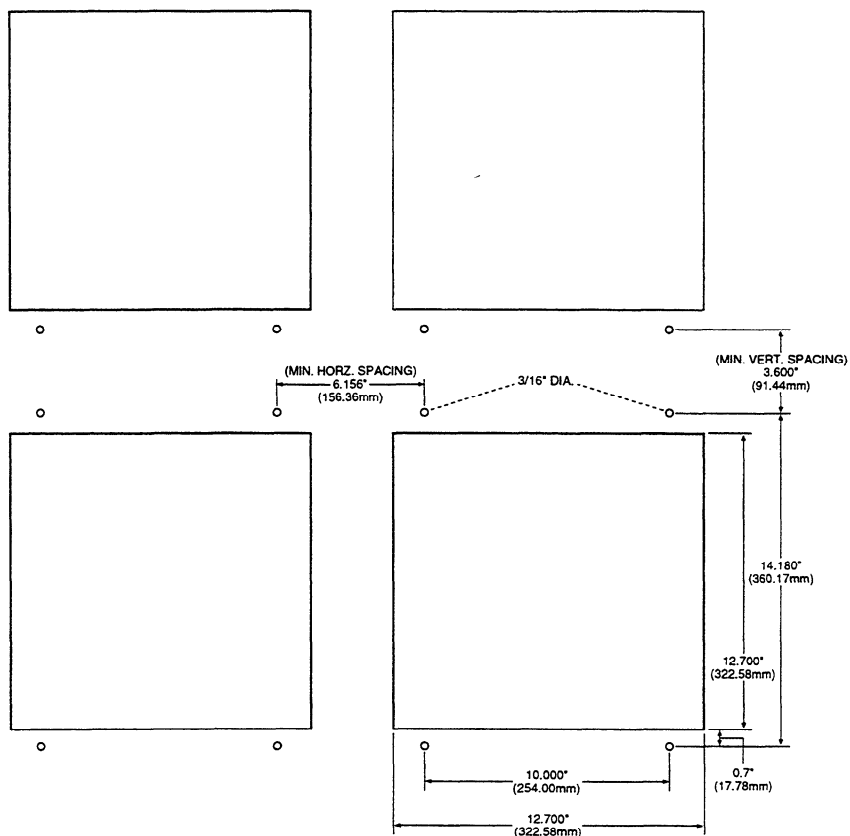
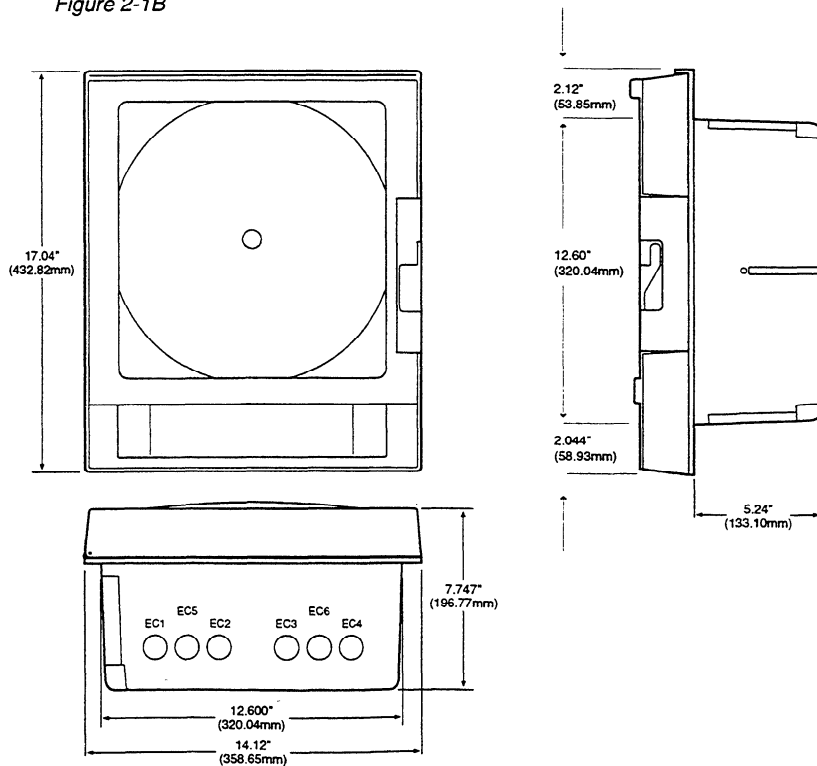

Figure 2-1B



---

## Preparations for Wiring 2.5

### 2.5.1 WIRING GUIDELINES

Electrical noise is a phenomenon typical of industrial environments. The following are guidelines that must be followed to minimize the effect of noise upon any instrumentation.

#### 2.5.1.1 INSTALLATION CONSIDERATIONS

Listed below are some of the common sources of electrical noise in the industrial environment:

- Ignition Transformers
- Arc Welders
- Mechanical contact relay(s)
- Solenoids

Before using any instrument near the devices listed, the instructions below should be followed:

1. If the instrument is to be mounted in the same panel as any of the listed devices, separate them by the largest distance possible. For maximum electrical noise reduction, the noise generating devices should be mounted in a separate enclosure.
2. If possible, eliminate mechanical contact relay(s) and replace with solid state relays. If a mechanical relay being powered by an instrument output device cannot be replaced, a solid state relay can be interposed to isolate the instrument. (Continued on next page)
3. A separate isolation transformer to feed only instrumentation should be considered. The transformer can isolate the instrument from noise found on the AC power input.
4. If the instrument is being installed on existing equipment, the wiring in the area should be checked to insure that good wiring practices have been followed.

#### 2.5.1.2 AC POWER WIRING

##### Earth Ground

The instrument includes noise suppression components that require an earth ground connection to function. To verify that a good earth ground is being attached, make a resistance check from the instrument chassis to the nearest metal water pipe or proven earth ground. This reading should not exceed 100 ohms. Each instrument should have a dedicated earth ground. Do not chain link multiple instrument ground wires.

##### Neutral (For 115VAC)

It is good practice to assure that the AC neutral is at or near ground potential. To verify this, a voltmeter check between neutral and ground should be done. On the AC range, the reading should not be more than 50 millivolts. If it is greater than this amount, the secondary of this AC transformer supplying the instrument should be checked by an electrician. A proper neutral will help ensure maximum performance from the instrument.

#### 2.5.1.3 WIRE ISOLATION/SEGRATION

The instrument is designed to promote proper separation of the wiring groups that connect to the instrument. The AC power wire terminals are located near the top of the instrument boards. The analog signal terminals are located near the bottom of the instrument boards. Maintain this separation of the wires to insure the best protection from electrical noise. If the wires need to be run parallel with any other wiring type(s), maintain a minimum 6 inch space between the wires. If wires must cross each other, do so at 90 degrees to minimize the

contact with each other and amount of cross talk. Cross talk is due to the EMF (Electro Magnetic Flux) emitted by a wire as current passes through it.

#### 2.5.1.4 USE OF SHIELDED CABLE

Shielded cable helps eliminate electrical noise being induced on the wires. All analog signals should be run with shielded cable. Connection lead length should be kept as short as possible, keeping the wires protected by the shielding. The shield should be grounded at one end only. The preferred grounding location is at the sensor, transmitter or transducer.

#### 2.5.1.5 NOISE SUPPRESSION AT THE SOURCE

Usually when good wiring practices are followed, no further noise protection is necessary. Sometimes in severe environments, the amount of noise is so great that it has to be suppressed at the source. Many manufacturers of relays, contactors, etc. supply "surge suppressors" which mount on the noise source.

For those devices that do not have surge suppressors supplied, RC (resistance-capacitance) networks and/or MOV (metal oxide varistors) may be added.

Inductive Coils - MOV's are recommended for transient suppression in inductive coils connected in parallel and as close as possible to the coil. See Figure 2-2. Additional protection may be provided by adding an RC network across the MOV.

Contacts - Arcing may occur across contacts when the contact opens and closes. This results in electrical noise as well as damage to the contacts. Connecting a RC network properly sized can eliminate this arc.

For circuits up to 3 amps, a combination of a 47 ohm resistor and 0.1 microfarad capacitor (1000 volts) is recommended. For circuits from 3 to 5 amps, connect 2 of these in parallel. See Figure 2-3.

**FIGURE 2-2**

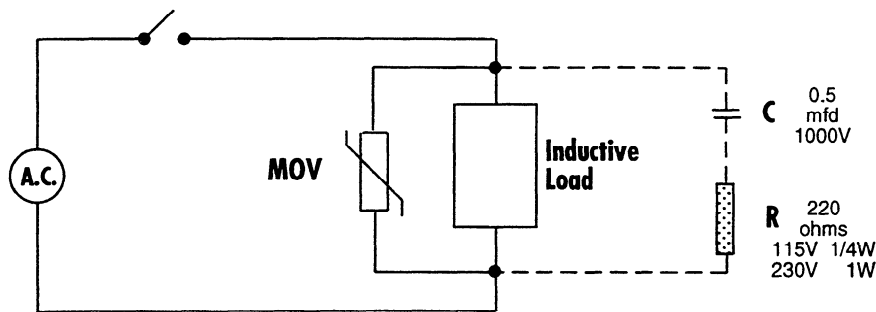

**FIGURE 2-3**

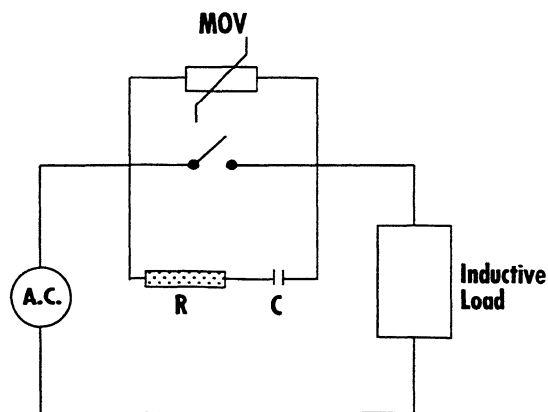

## 2.5.2 SENSOR PLACEMENT (THERMOCOUPLE OR RTD)

If the temperature probe is to be subjected to corrosive or abrasive conditions, it should be protected by the appropriate thermowell. The probe should be positioned to reflect true process temperature:

In liquid media - the most agitated area.

In air - the best circulated area.

### THERMOCOUPLE LEAD RESISTANCE

Thermocouple lead length can affect instrument accuracy, since the size (gauge) and the length of the wire affect lead resistance.

To determine the temperature error resulting from the lead length resistance, use the following equation:

$$T_{err} = TLe * L \quad \text{where; } TLe = \text{value from appropriate Table}$$

$$L = \text{length of leadwire in thousands of feet.}$$

TABLE 1

Temperature error in °C per 1000 feet of Leadwire									
AWG No.	Thermocouple Type								
	J	K	T	R	S	F	B	N	C
10	.68	1.71	.76	2.05	2.12	1.15	14.00	2.94	2.53
12	1.08	2.68	1.21	3.30	3.29	1.82	22.00	4.68	4.07
14	1.74	4.29	1.95	5.34	5.29	2.92	35.00	7.44	6.37
16	2.74	6.76	3.08	8.30	8.35	4.60	55.50	11.82	10.11
18	4.44	11.00	5.00	13.52	13.65	7.47	88.50	18.80	16.26
20	7.14	17.24	7.84	21.59	21.76	11.78	141.00	29.88	25.82
24	17.56	43.82	19.82	54.32	54.59	29.67	356.50	75.59	65.27

TABLE 2

Temperature error in °F per 1000 feet of Leadwire									
AWG No.	Thermocouple Type								
	J	K	T	R	S	E	B	N	C
10	1.22	3.07	1.37	3.68	3.81	2.07	25.20	5.30	4.55
12	1.94	4.82	2.18	5.93	5.93	3.27	39.60	8.42	7.32
14	3.13	7.73	3.51	9.61	9.53	5.25	63.00	13.38	11.47
16	4.93	12.18	5.54	14.93	15.04	8.28	99.90	21.28	18.20
18	7.99	19.80	9.00	24.34	24.56	13.44	159.30	33.85	29.27
20	12.85	31.02	14.12	38.86	39.18	21.21	253.80	53.79	46.48
24	31.61	78.88	35.67	97.77	98.26	53.40	641.70	136.07	117.49

### Example

A recorder is to be located in a control room 660 feet away from the process. Using 16 AWG, Type J thermocouple, how much error is induced?

$$T_{err} = TLe * L = 4.93 (°F/1000 \text{ ft}) \text{ from Table 2.}$$

$$T_{err} = 4.93 (°F/1000 \text{ ft})$$

$$T_{err} = 3.3 °F$$

**RTD LEAD RESISTANCE**

RTD lead length can affect instrument accuracy. Size (gauge) and length of the wire used affects lead length resistance.

To determine the temperature error resulting from the lead length resistance, use the following equation:

$T_{err} = TLe * L$  where; TLe = value from Table 3 if 3 wire or Table 4 is 2 wire.  
L = length of leadwire in thousands of feet.

**TABLE 3 3 Wire RTD**

AWG No.	Error °C	Error °F
10	+/-0.04	+/-0.07
12	+/-0.07	+/-0.11
14	+/-0.10	+/-0.18
16	+/-0.16	+/-0.29
18	+/-0.26	+/-0.46
20	+/-0.41	+/-0.73
24	+/-0.65	+/-1.17

**TABLE 4 2 Wire RTD**

AWG No.	Error °C	Error °F
10	+/-5.32	+/-9.31
12	+/-9.31	+/-14.6
14	+/-13.3	+/-23.9
16	+/-21.3	+/-38.6
18	+/-34.6	+/-61.2
20	+/-54.5	+/-97.1
24	+/-86.5	+/-155.6

**Example**

An application uses 2000 feet of 18 AWG copper lead wire for a 3-wire RTD sensor. What is the worst-case error due to this leadwire length?

$T_{err} = TLe * L$

$TLe = +/- .46 (°F/1000 ft)$  from Table 1

$T_{err} = +/- .46 (°F/1000 ft) * 2000 ft$

$T_{err} = +/- 0.92 °F$

## Wiring Connections 2.6

All wiring connections are typically made to the instrument at the time of installation. Connections are made at the terminal boards provided, two 12 gauge wires maximum. Terminal boards are designated TB1 through TB13. See Figure 2-4 for the terminal board locations. The number of terminal boards present on the instrument depend upon the model number/hardware configuration.

**FIGURE 2-4**

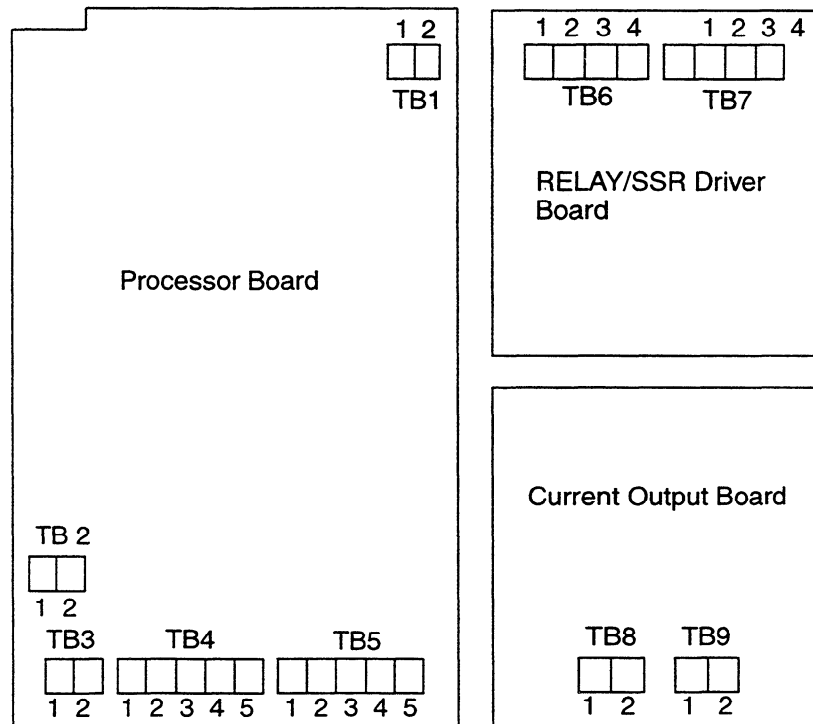

### 2.6.1 ELECTRICAL CONDUIT OPENINGS

The instrument case will have 3 or 4 conduit openings, depending upon the number of outputs specified. To help minimize electrical noise that may adversely affect the operation of the instrument the wires indicated below should be routed through the conduit opening specified. See Figure 2-1 (page 9) for conduit opening locations.

EC4-	AC Power Input
EC1/EC2-	Analog input and mADC outputs
EC3/EC4-	SPST relay or SSR driver outputs

Unused conduit openings should be sealed.

### 2.6.2 AC POWER WIRING CONNECTIONS

**WARNING: Avoid electrical shock. AC power wiring must not be connected at the source distribution panel until all wiring connections are completed.**

### FIGURE 2-5

#### AC Instrument Power Input

Connect the 115 VAC hot and neutral to terminals 1 and 2 respectively of TB1. See Figure 2-4 (page 14) for Terminal Board locations on the instrument. Connect the 230 VAC one leg to each terminal, be sure to check the position of the Voltage Selector switch provided with 230 VAC instruments. The switch position must match the voltage input to the instrument.

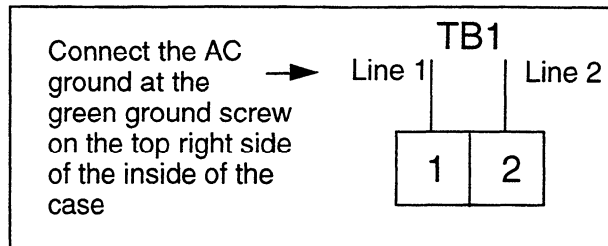

### FIGURE 2-6

#### Thermocouple Inputs

Use TB4 for the Pen 1 input, and TB5 for the Pen 2 input. Connect the positive leg of the thermocouple to terminal 1, and the negative to terminal 2. Be sure that the input conditioning jumpers are properly positioned for a thermocouple input. See Appendix A-1 (page 62).

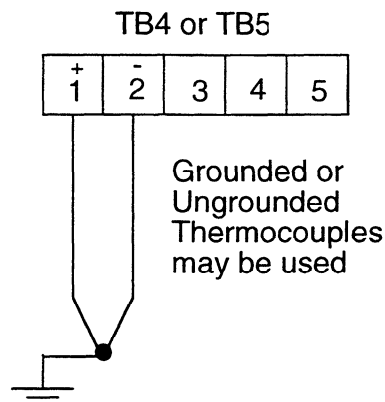

### FIGURE 2-7

#### RTD Inputs

Use TB4 for the Pen 1, and TB5 for the Pen 2 input. Connections are shown for 3 wire and 2 wire RTD inputs. If a three wire device is used, install the common legs to terminals 2 and 3. If a two wire device is used, install a jumper between terminals 2 and 3. Be sure that the input conditioning jumpers are properly positioned for an RTD input. See Appendix A-1 (page 62).

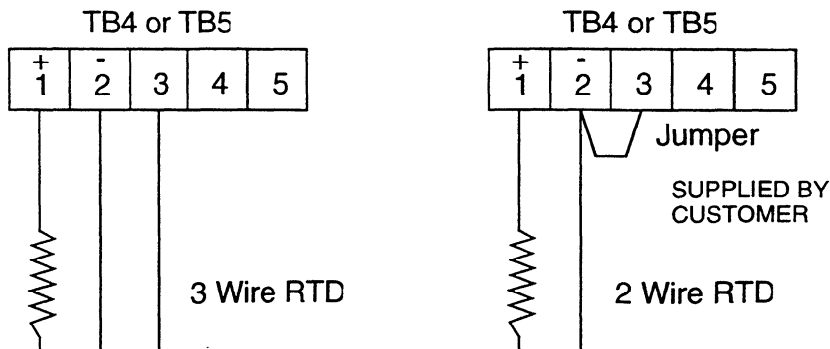

### FIGURE 2-8

#### Volt, Millivolt and milliamp Input

Make the volt, millivolt and milliamp connections as shown below. Use TB4 for the Pen 1 input, and TB5 for the Pen 2 input. Terminal 1 is positive and terminal 2 is negative. The milliamp input requires the installation of an appropriate shunt resistor (ordered separately) between terminals 1 and 2. Be sure that input conditioning jumpers are in the correct positions for the input being connected. See Appendix A-1 (page 62).

**NOTE:** Fault Detection is not functional for 0-5V or 0-20mA inputs.

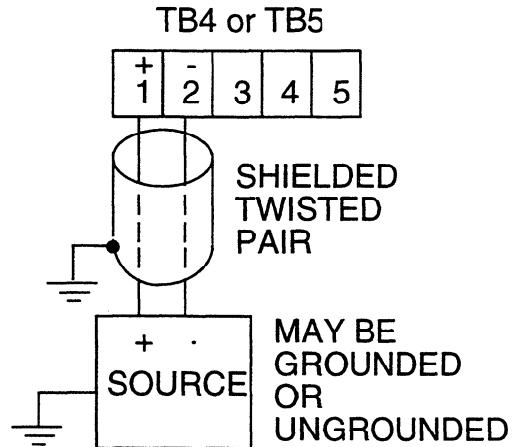

### FIGURE 2-9

#### Remote Setpoint Input VDC , mADC

If Remote Setpoint option has been specified, make connections as shown. The remote setpoint input may be selected as either 0 to 5 VDC or 1 to 5 VDC input in the Program mode section. Make sure the configuration properly matches the input used. Use TB4 for Pen 1, and TB5 for Pen 2 if Pen 2 is provided and specified with the Remote Setpoint option. Connect the positive lead to terminal 4, and the negative lead to terminal 3 (Terminal 3 is the ground, terminal 4 is the input, terminal 5 is 5 VDC.) If a 4 to 20 mADC remote setpoint is to be used, the instrument remote setpoint input should be configured for 1 to 5VDC in the Program mode, and a 250 ohm resistor should be installed across terminals 4 and 3. A 250 ohm resistor is provided with the instrument, one per pen. The resistor(s) are shipped in the plastic bag that is clipped to the inside of the instrument cover. This is the same bag that contains the spare pen cartridge(s).

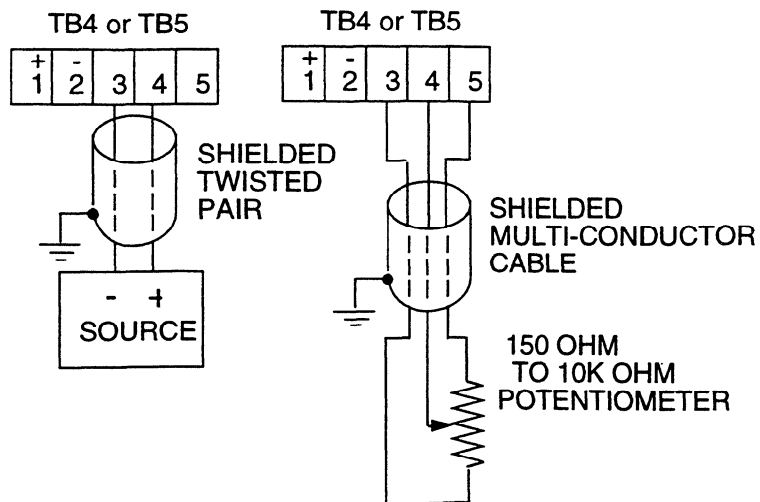

## FIGURE 2-10

### Digital Communications Options

Connections are made as shown using TB2. Refer to the Protocol Manual, Form #2878 for more details regarding the connections and how to use this option. This document is provided only when this option has been specified. If the communications network continues on to other instruments, connect the cable shields together, but not to the instrument. A terminating resistor should be installed at the terminals of the last unit in the communications loop. If the communications network ends at the instrument, the shield is not connected.

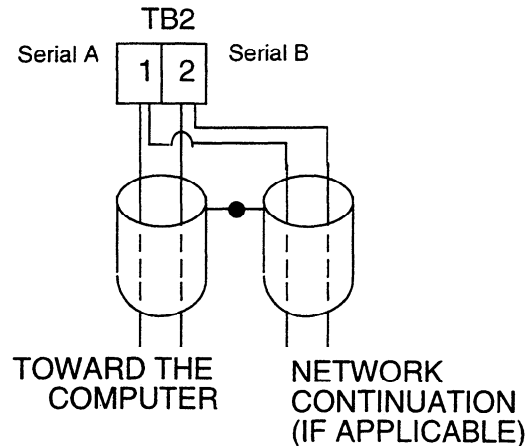

## 2.6.4 OUTPUT CONNECTIONS

Relay output(s), if provided in the instrument, may be assigned to control or alarm output functions for Pen 1 and/or Pen 2 (if present). Current outputs may be assigned to control and process value retransmission output for Pen 1 and/or Pen 2 (if present). The assignment of the output function(s) are/is accomplished in the Program mode. SPST relay and/or SSR driver output(s) is/are designated as Relay A through Relay D.

## FIGURE 2-11

### SPST Relay Output

Connections are made to relays A through D as shown. Terminal connections are made using TB6 (Relay/SSR Driver A, B) and TB7 (Relay/SSR Driver C, D).

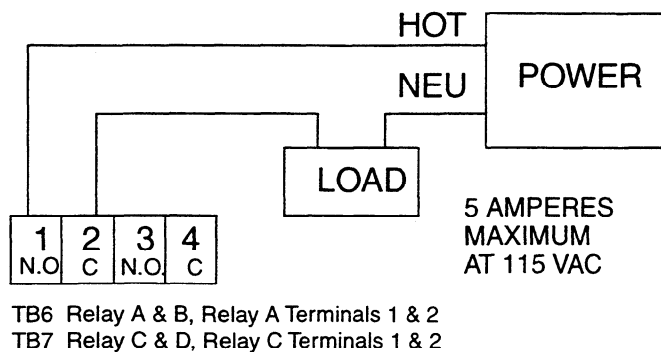

---

**FIGURE 2-12**

## SSR Driver Output

Connections are made to relays D through A as shown. Terminal connections are made using TB7 and TB6, depending on the number of SSR Driver outputs specified.

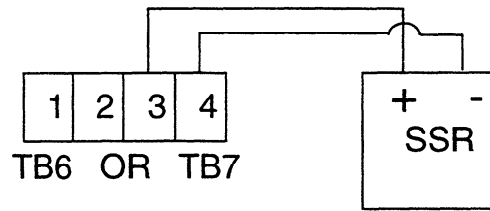

---

**FIGURE 2-13**

## Current Output

Connections are made to current outputs A and B as shown. Each current output is programmable as either 4 to 20 mA DC or 0 to 20 mA DC. Each output must be assigned to the desired function in the Program mode. Terminal connections are made using TB8 and TB9 for current output A and B respectively. Connect positive lead (+) to terminal 1 and the negative lead (-) to terminal 2. Each current output will operate up to a 650 ohms maximum load.

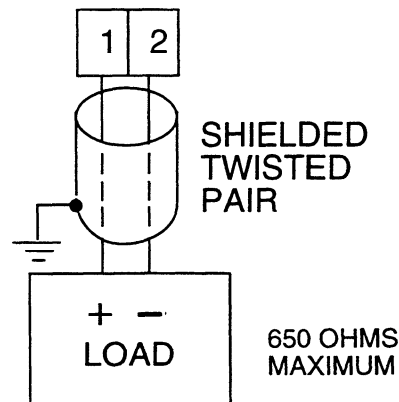

**FIGURE 2-14**

**Transmitter Power Supply Input**

If the isolated 24 VDC regulated transmitter power supply has been specified, the connections should be made as shown. Connections are made using TB3, terminal 1 is positive and terminal 2 is negative. The power supply is capable of providing the power needed by up to 2 transducers (40 mADC maximum).

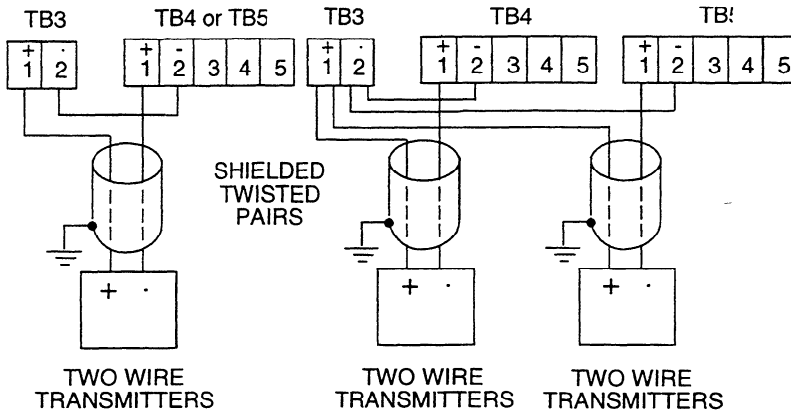

**FIGURE 2-15**

**Position Proportioning Control Output**

Position Proportioning control requires that two relays (or SSR Drivers) and the Position Proportioning Auxiliary input be specified. On a dual pen instrument, either pen may be configured with Position Proportioning control provided the outputs and auxiliary inputs have been properly specified.

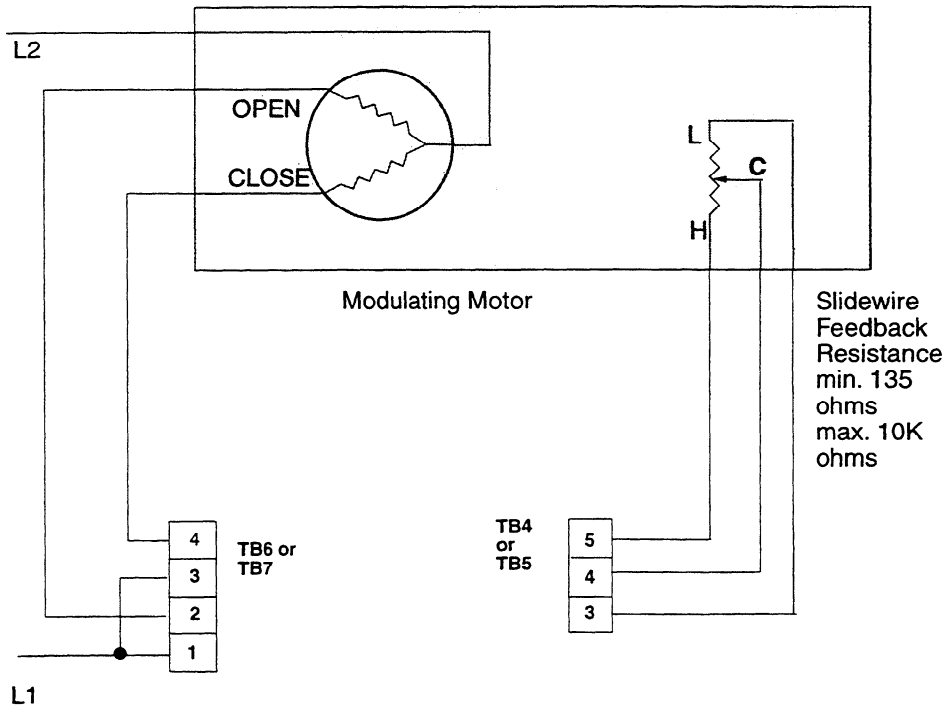

## Configuration 3.1

After completing installation and wiring of the instrument the configuration (set up) procedures must be performed to prepare the instrument for operation on the intended application. The procedures include selecting specific parameters, entering data and possible jumper positioning. Once properly configured the instrument will retain the user selections in memory so this procedure need not be repeated unless required by changes in the application.

Parameter selections and data entry are made via the front keypad. To ease configuration and operation, user entered data has been divided up into several sections referred to as modes. Each mode contains a different type of data or may be used for specific operating functions. For two pen instruments, some modes are common to both pens. These modes are as follows:

### RECORDER-

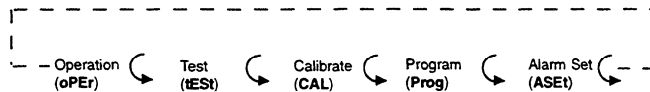

### RECORDING CONTROLLER-

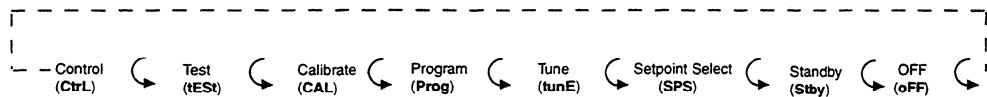

MODE	DISPLAY CODE	FUNCTION	DESCRIPTION
Off	oFF	Operation	Outputs and Alarms are Off Chart may stop rotating(selectable)
Operate*	oPEr	Operation	Limits and Alarms are Active
Control**	Ctrl	Control	Outputs and Alarms are Active
Test	tESt	Service	Tests Instrument Operation
Calibration	CAL	Service	Calibrates, Resets Instrument
Program	Prog	Configuration	Configure Operating Parameters
Alarm Set*	ASEt	Configuration & Operation	Enter Alarm Settings
Tune**	tunE	Configuration & Operation	Enter Tune and Alarm Settings
Setpoint Selection**	SPS	Operation	Selects Remote or Local Setpoint Operation (Remote Setpoint Optional)

\* Applies to Recorders

\*\* Applies to Recording Controllers

Manual**	<b>Stby</b>	Operation	Provides for manual operation of proportional output
Enable	<b>EnAb</b>	Configuration	Mode security system, can lock out everything except Off and Control (See Appendix A-1, page 62, for hardware lockout information)

\* Applies to Recorders

\*\* Applies to Recording Controllers

Associated with each mode is a series of unique displays that are accessed via the front keypad.

Prior to first time operation of the instrument, the configuration procedures for the Program and Tune modes must be performed as applicable. Calibration and Test modes are not used as part of the instrument configuration or operation. These are used for service and maintenance functions and are discussed in Section 5.4 & 5.5 of this manual (page 46 - 54).

## Shipped Configuration/Jumper Positioning 3.2

Each instrument is factory shipped ready to accept a thermocouple input on TB 4 and TB 5. All parameters in each mode are set to default values. These defaults are shown in tabular form after the description for each mode. Instrument AC power input is as specified in the instrument model number and is shown on the ratings label. The 230 VAC option includes a switch in the instrument for selecting either 230 VAC or 115 VAC input power. If this feature is provided, verify AC input and switch position before applying power to the instrument.

### 3.2.1 JUMPER POSITIONING

Jumpers are used to condition the sensor inputs and to provide a security lockout feature. All jumpers are located on the instrument Processor board. The instrument board layout and jumper locations and functions are shown in Appendix A-1 (page 62). Check the jumper positions in the instrument and verify that they are in the proper position for the intended application.

*The sensor input jumpers JU4, JU5, JU6 and JU7 condition the sensor input signals and must be used in conjunction with input type selections made in the Program mode. (page 28).*

## Operation Summary 3.3

### 3.3.1 MODE SELECTION

If the instrument is either in the Off mode, the Operation mode (recorders), or the Control mode (recording controllers), repeated pressing and releasing of the SCROLL key will cause the instrument to display the code corresponding to each mode that is enabled. To enter a mode while the code is displayed, press the DOWN key. If a mode does not appear, refer to the Enable mode section for information on how to determine if the mode is on.

Entry into any mode except the Operate, Control, Tune, Manual, or Enable modes, will cause the output(s) to turn off and any process re-transmission value output(s) to be 0 %. Entry into the Off mode will cause process re-transmission to remain active.

---

## Start up Procedures 3.4

All configuration parameters are listed in Tables 3-1 through 3-5.

For a single pen instrument, parameters for each mode are displayed in the left display. If the instrument being configured is a two pen model, a sequence of applicable parameters will be displayed in the Pen 2 display after the Pen 1 parameters have been reviewed and configured. After the Pen 2 parameters have been completed, parameters common to both pens will be configured and displayed in the Pen 1 display.

The instrument is provided with a time out feature. If the instrument is in any mode (except while executing a calibration or test procedure) and no keypad activity takes place for 30 seconds, the instrument will time out and exit the mode automatically. The display will become the code for the respective mode. If a mode code is displayed for 5 seconds with no keypad activity, then the time out will cause the instrument to proceed to either the Control or Off mode, depending upon whether the mode entered was an operational mode (Tune, Manual, Enable) or non operational mode (Test, Program, Cal).

---

### 3.4.1 POWER UP PROCEDURE

#### Step 1

Verify that all electrical connections have been properly made before applying power to the instrument.

#### Step 2

Upon power up, a brief flash on all displays (upper and, if equipped, lower) will occur to show the instrument is "alive". Then **8XXX** will be displayed (X representing digits), then **XXXX**, then **XXXX**, identifying the twelve digit model number as defined in the order matrix. Next, the EPROM part number will be indicated **P-XX**. After the EPROM part number, the software revision level will be displayed in the format **rx.xx** followed by **P.dn** (if **Pen Action on Power Up, PAPu**, in Program Mode is set to 0, pens go to "home" position on power up). During this display, the decimal point after the "P" will blink to show the mode is active. Upon successful completion of this routine, **Ctrl**, **OPER** or **OFF** will be displayed for about three seconds. The mode displayed will be the mode that the instrument was in when the power was turned off. During this time the operator may select another mode (Tune, Manual, Enable) or non-operational mode (Test, Program, Cal).

#### Step 3

If any error messages are displayed, refer to Section 5.6 (page 55) for a definition of the error message and the required action.

---

## Front Panel Operation 3.5

---

### 3.5.1 DIGITAL DISPLAY AND STATUS LEDs

The digital display provided for each pen has 4 digits and a decimal point. Each digit has seven segments and is capable of producing numeric characters from 0-9 and certain alpha characters. The digital display is used to provide indication of process variable as well as displaying codes used for configuration and operation of the instrument. The display includes the following Status Indicator LED's;

**RECORDER:**

<b>ALRM1</b>	Red	Rcdr - Lights when Alarm 1 is on. Limit - Lights when Limit has been exceeded.
<b>ALRM2</b>	Red	Lights when Alarm 2 is on.
<b>C</b>	Red	Lights to indicate that the process value is in terms of degrees C (Celsius).
<b>F</b>	Red	Lights to indicate that the process value is in terms of degrees F (Fahrenheit).
<b>U</b>	Red	Lights to indicate that the process value is in terms of Engineering units.
<b>-</b>	Red	Lights to indicate a negative displayed value.
<b>SP</b> (Limits only)	Green	Indicates that the value displayed is the setpoint

**RECORDING CONTROLLER:**

<b>MAN</b>	Amber	Lights when the Manual <b>StbY</b> mode is on.
<b>OUT1</b>	Red	Lights when Output 1 is on or mADC output selected.
<b>OUT 2</b>	Amber	Lights when Output 2 is on or mADC output selected..
<b>ALRM</b>	Red	Lights when either Alarm is on.
<b>C</b>	Red	Lights to indicate that the process value is in degrees C (Celsius).
<b>F</b>	Red	Lights to indicate that the process value is in degrees F (Fahrenheit).
<b>U</b>	Red	Lights to indicate that the process value is in terms of Engineering units.
<b>SP</b>	Green	Indicates that the value displayed is the setpoint.
<b>-</b>	Red	Lights to indicate a negative displayed value.

Refer to Figure 1-2 (page 7) for the display features illustration.

**3.5.2 KEYPAD CONTROLS**

The keys on the keypad functions include:

- SCROLL:** Used to :
1. Display the enabled modes.
  2. While in a mode, used to sequence the parameter codes and values.
  3. Exit some Test and Calibration functions
  4. Work in conjunction with other keys:
    - a. With the UP key to display proportional output %
    - b. With the DOWN Key;
      - 1) On power up to alter model #
      - 2) Enter Cal/Test functions
- UP:** Used to:
1. Exit a mode.
  2. Turn a mode On in the Enable mode
  3. Increase a parameter numerical value
  4. View the setpoint for Pen 1 (Press release)
  5. Increase the setpoint value (Press hold)
  6. Work in conjunction with other keys:
    - a. With the SCROLL key to display proportional output %
    - b. With the DOWN key;
      - 1) Lamp test (Press release)
      - 2) Enter the Enable mode (Press and hold for 11 seconds)

- DOWN:** Used to:
1. Enter a mode
  2. Turn a mode Off in the Enable mode
  3. Decrease a parameter numerical value
  4. View the setpoint for Pen 2 (if provided)
  5. Decrease the setpoint value (Press hold)
  6. Step display through parameter codes in a mode
  7. Work in conjunction with other keys:
    - a. With the SCROLL key;
      - 1) On power up to alter the model number displayed
      - 2) Enter Cal/Test functions
    - b. With the UP key;
      - 1) Lamp test (Press release)
      - 2) Enter the Enable mode (Press and hold for 11 seconds)
- RESET:** Used to: (Limit Only)      Reset the limit output only when the condition that caused the limit has been cleared.
- AUTO/MAN:** Used to:      1. In the Control mode to enter the Manual mode if proportional output(s) selected  
The upper key is for      2. In the Manual mode to enter the Control mode if proportional output(s) selected  
Pen 1, the lower key      is for Pen 2 (if provided)

**FIGURE 3-1**

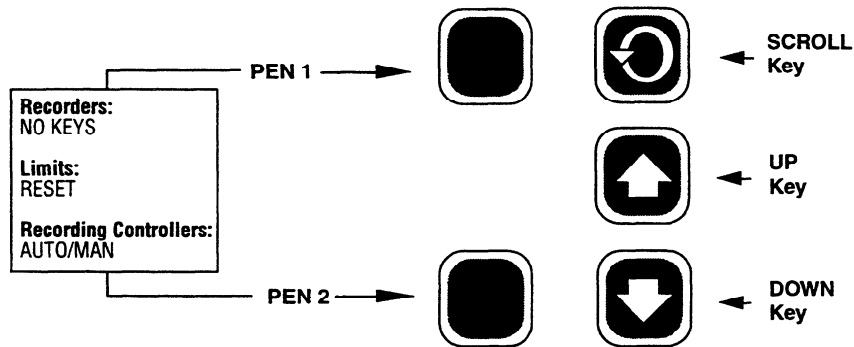

**LAMP TEST**

From the Off, OPEr or Control modes, all display and status LEDs can be illuminated simultaneously by depressing the UP and DOWN keys at the same time. Any defective LEDs will not light.

**CHANGE CHART (also see Changing Charts, Section 5.2)**

If the UP and DOWN keys are held depressed for more than 2 seconds but less than 4 seconds, the display will show **CChg** momentarily. The pen(s) will move to and remain at a point above the top graduation on the chart and the chart will stop rotating to allow the chart to be changed. The pens will remain fully upscale with the chart OFF; otherwise, the unit will continue to operate normally in the current mode. To restore pen(s) position and chart rotation, press the UP and DOWN keys for more than 2 seconds, but less than 4 seconds.

**PEN RESYNCHRONIZATION**

To resynchronize the pen(s), depress the UP and DOWN keys for 4 seconds, the display will show **P dn** momentarily, the pen(s) are driven to the "Pen Home" position below the bottom graduation on the chart while the unit resynchronizes their position. After about 14 seconds, the pen(s) will return to their correct position. All other functions of the unit's present mode continue to operate normally.

# PROGRAM MODE FLOW CHART

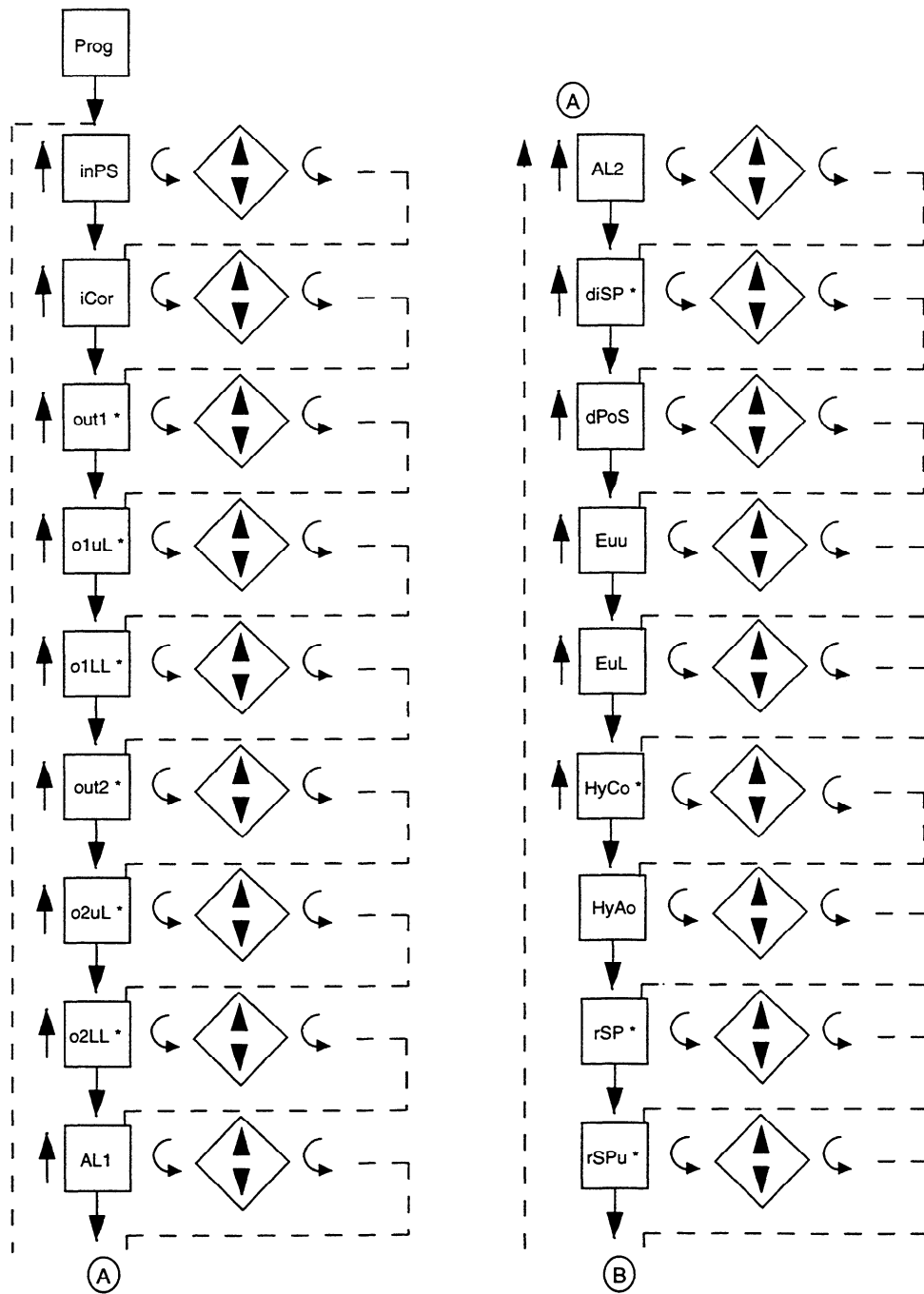

\* Applies to Recording Controllers Only

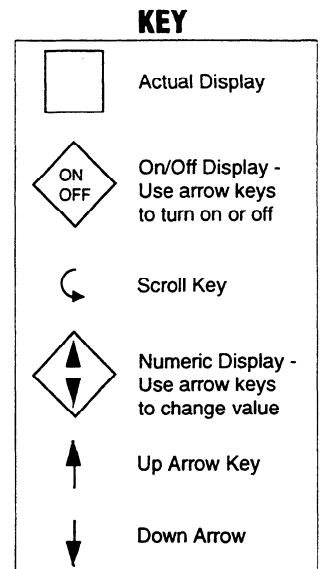

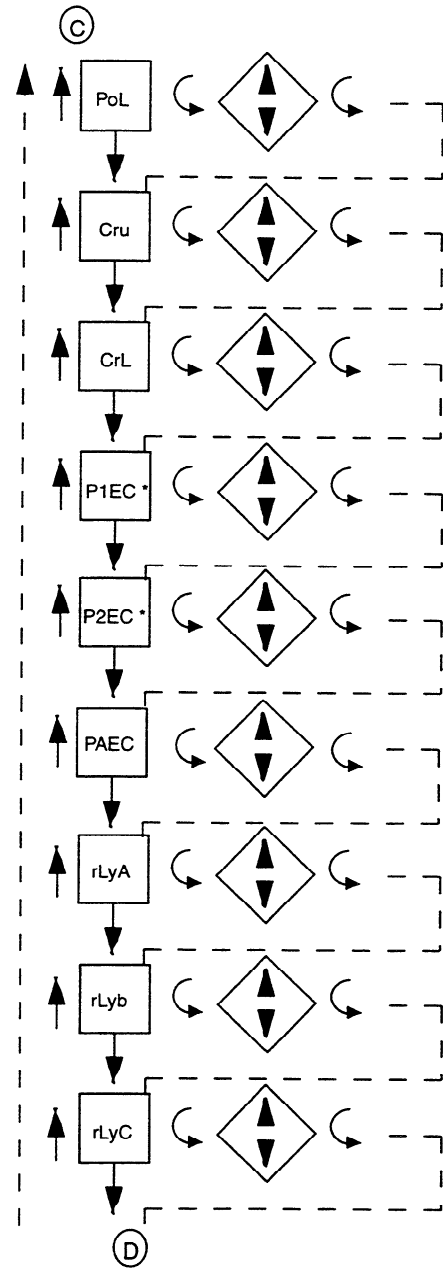
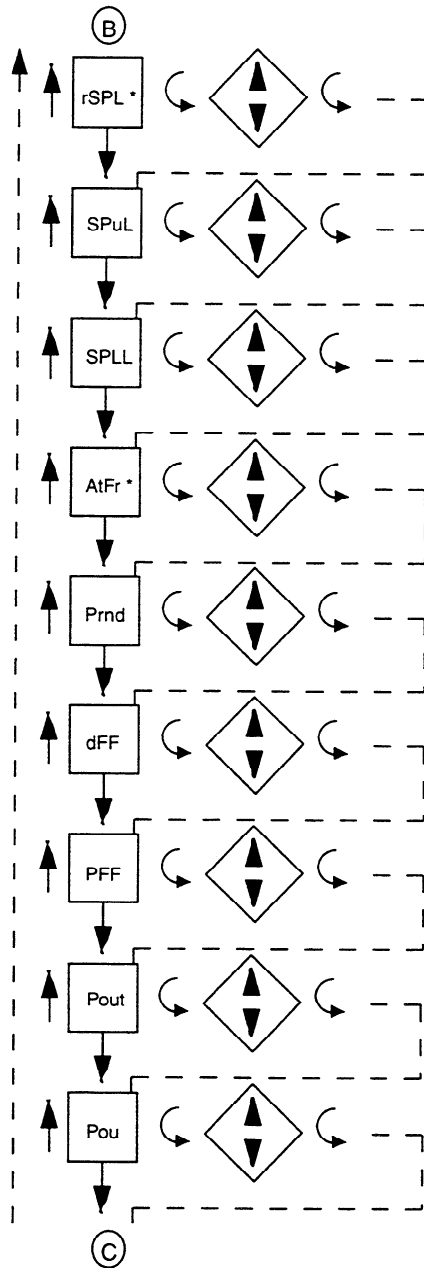

**KEY**

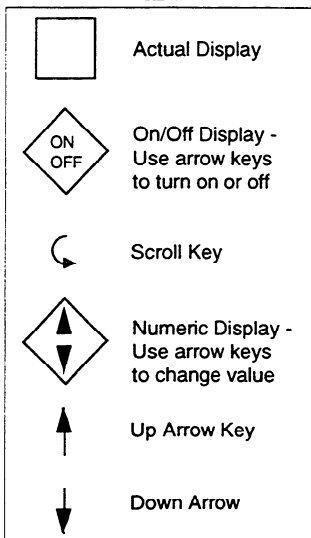

**\* Applies to Recording Controllers Only**

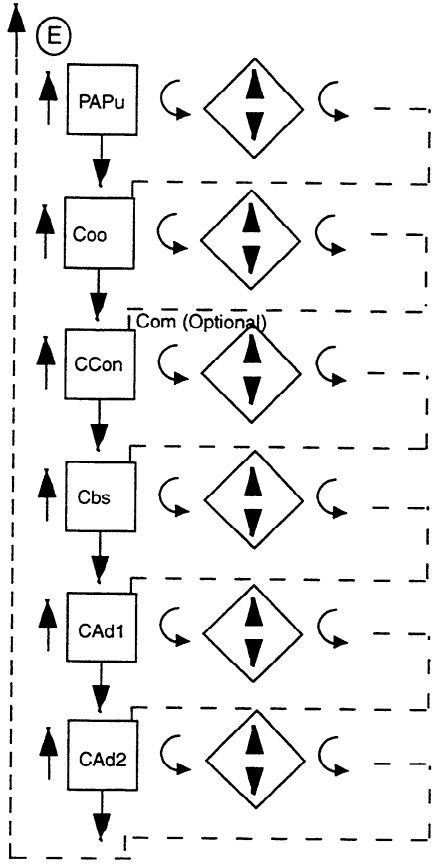
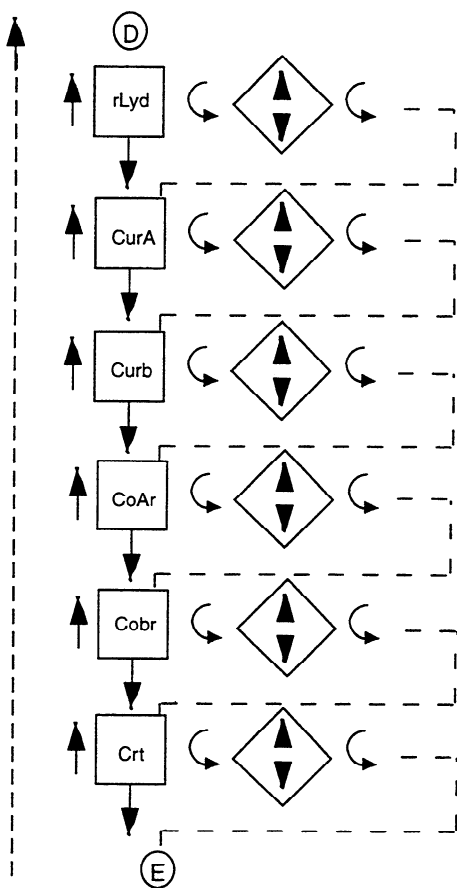

**\* Applies to Recording Controllers Only**

### TABLE 3-1 PROGRAM MODE CONFIGURATION PROCEDURE

Press the SCROLL key until **Prog** is displayed. Press the DOWN key to enter the Program mode. Pen 1 will be displayed in the left display. To enter the Pen 1 parameter, press the DOWN key. To enter the Pen 2 parameter, if provided, press the SCROLL key, then the DOWN key. To enter the unit parameter, press the SCROLL key with either Pen 1 or Pen 2 displayed until unit is displayed, then press the DOWN key. Press the SCROLL key to advance the display through the parameter codes and their values. Use the UP and DOWN keys to adjust the values. After adjusting a parameter, press the SCROLL key to proceed to the next parameter. After all selections have been made, press the UP key with a parameter in the display (not a setting) to exit the mode. For two pen instruments the parameters and values which are applicable to Pen 1 will appear in the left display, then the parameters and values which are applicable to Pen 2 will appear in the right display. Then the unit parameters and values will appear in the left display.

For illustration purposes all available Program mode parameters have been listed. The parameters that will appear on the specific instrument will depend upon the model number (hardware configuration) of the instrument and on the parameter selections previously made.

For future reference, record the parameter selections for the application in the "Your Setting" column and on the Software Reference Sheet in Appendix E (Page 72). Use the Software Reference Sheet to program the instrument.

To prevent unauthorized changes to the Program mode, the mode can be disabled (turned off) in the Enable mode.

**NOTE: All Steps and Values with an \* apply to pen that is a Recording Controller.**

STEP	DESCRIPTION	DISPLAY CODES	AVAILABLE SETTINGS	FACTORY SETTING	YOUR SETTING
1	Input Select	inPS	0=J T/C degrees C 1=J T/C degrees F 2=K T/C degrees C 3=K T/C degrees F 4=T T/C degrees C 5=T T/C degrees F 6=R T/C degrees C 7=R T/C degrees F 8=S T/C degrees C 9=S T/C degrees F 10=E T/ C degrees C 11=E T/C degrees F 12=B T/ C degrees C 13=B T/C degrees F 14=N T/ C degrees C 15=N T/C degrees F 16=C T/ C degrees C 17=C T/C degrees F 20=RTD degrees C 21=RTD degrees F 30=0 to 5 VDC 31=1 to 5 VDC 32=0 to 50 mVDC 33=10 to 50 mVDC 34=0 to 25 mVDC	1	
					<b>NOTE:</b> <b>Fault Detection is not functional for 0-5V or 0-20mA inputs.</b>
2	Input Correction	iCor	-300 to 300 degrees/units	0	
3*	Output 1	out1	0 = None 1=On-Off- Direct 2=On-Off- Reverse 3=Time Proportioning- Direct 4=Time Proportioning -Reverse	0	

STEP	DESCRIPTION	DISPLAY CODES	AVAILABLE SETTINGS	FACTORY SETTING	YOUR SETTING
			5=Current Proportioning -Direct 6=Current Proportioning -Reverse 7=Position Proportioning (open)		
4*	Output 1 Percent Upper Limit ( <b>o1uL</b> and <b>o1LL</b> will not be seen if <b>out1</b> = 0,1,2)	<b>o1uL</b>	0 to 100 percent	<b>100</b>	
5*	Output 1 Percent Lower Limit	<b>o1LL</b>	0 to 100 percent	<b>0</b>	
6*	Output 2	<b>out2</b>	0 = None (Position Proportioning - Direct Closed) 1=On-Off- Direct 2=On-Off- Reverse 3=Time Proportioning- Direct 4=Time Proportioning-Reverse 5=Current Proportioning- Direct 6=Current Proportioning -Reverse 7=Position Proportioning (Reverse/Closed)	<b>0</b>	
7*	Output 2 Percent Upper Limit ( <b>o2uL</b> and <b>o2LL</b> will not be seen if <b>out2</b> = 0,1,2,7)	<b>o2uL</b>	0 to 100 percent	<b>100</b>	
8*	Output 2 Percent Lower Limit	<b>o2LL</b>	0 to 100 percent	<b>0</b>	
9	Alarm 1 the Alarm Point is selected in the Tune mode	<b>AL1</b>	0 to 6 0 = None 1=Process Alarm-Direct 2=Process Alarm-Reverse 3=Deviation Alarm-Direct * 4=Deviation Alarm-Reverse * 5=Deviation Band Alarm-Open within band * 6=Deviation Band Alarm-Closed within band *	<b>0</b>	
10	Alarm 2	<b>AL2</b>	Same selections as Alarm 1	<b>0</b>	
11*	Display Select	<b>diSP</b>	1=Process value only 2=Process value/setpoint 3=Deviation only 4=Deviation and setpoint 5=Setpoint only	<b>1</b>	
12	Decimal Position	<b>dPoS</b>	0 to 3 0=None 1=One decimal place 2=Two decimal places 3=Three decimal places RTD and thermocouple inputs are limited to either 0 or 1 decimal positions	<b>0</b>	
13	Engineering Units Upper Value ( <b>Euu</b> and <b>EuL</b> will be seen if the pen input select = 30,31,32,33,34)	<b>Euu</b>	-9999 to 9999	<b>1000</b>	
14	Engineering Units Lower Value	<b>EuL</b>	-9999 to 9999	<b>0</b>	

STEP	DESCRIPTION	DISPLAY CODES	AVAILABLE SETTINGS	FACTORY SETTING	YOUR SETTING
15*	Hysteresis for Control Outputs	HyCo	0 to 300 Width of Hysteresis Band (See page 66 for definition)	3	
16	Hysteresis for Alarm Outputs	HyAo	0 to 300 Width of Hysteresis Band (see page 66 for definition)	3	
17*	Remote Setpoint If rSP is set to zero then rSPu and rSPL are not seen	rSP	0 to 2 0=Not Used 1=1 to 5 VDC 2=0 to 5 VDC	0	
18*	Remote Setpoint Upper Value	rSPu	-9999 to 9999	1400	
19*	Remote Setpoint Lower Value	rSPL	-9999 to 9999	0	
20*	Setpoint Upper Limit	SPuL	-9999 to 9999	1400	
21*	Setpoint Lower Limit	SPLL	-9999 to 9999	0	
22*	Automatic Transfer	AtFr	0 to 2 0 = No Automatic Transfer 1=Transfers when the process value goes below the setpoint 2=Transfers when the process value goes above the setpoint	0	
23	Process Rounding of Displayed Value	Prnd	0 to 100 0 = No rounding	0	
24	Display Filter Factor	dFF	1 to 20 1= no filtering (number of values averaged)	1	
25	Process Filter Factor	PFF	Same selection as dFF	1	
26	Process Value Output Retransmission (If Pout =0 then Pou and PoL will not be displayed)	Pout	0=Not selected 1=Selected	0	
27	Process Output Upper Value	Pou	-9999 to 9999	2000	
28	Process Output Lower Value	PoL	-9999 to 9999	0	
29	Chart Range Upper Value	Cru	-9999 to 9999	200	
30	Chart Range Lower Value	CrL	-9999 to 9999	0	
31*	Proportional Output 1 Action on Error Condition (If out1= 0,1,2 then P1EC will not be displayed)	P1EC	0 to 100%	0	
32*	Proportional	P2EC	0 to 100%	0	

STEP	DESCRIPTION	DISPLAY CODES	AVAILABLE SETTINGS	FACTORY SETTING	YOUR SETTING
	Output 2 Action on Error Condition (If <b>out2</b> = 0,1,2,7 then <b>P2EC</b> will not be displayed)				
33	Pen Action on Error Condition	<b>PAEC</b>	0 or 1 0 = Pen goes to 0 % of chart 1 = Pen goes to 100 % of chart	<b>1</b>	

Pressing the SCROLL key with the **PAEC** parameter value displayed in the Pen 1 window will advance the display of a single pen instrument to the unit parameters. Pressing the SCROLL key with the **PAEC** parameter displayed in the Pen 1 window of a two pen instrument will advance the display to be **PENS** in the Pen 2 window. The Pen 2 Program mode parameter selections can be made now. Pressing the SCROLL key with the **PAEC** parameter value displayed in the Pen 2 window will cause the display to advance to the unit parameters displayed in the Pen 1 window.

#### UNIT PARAMETERS

34	Relay A Assignment	<b>rLyA</b>	0 to 8 1=Assigned to Alarm 1-Pen 1 2=Assigned to Alarm 2-Pen 1 3=Assigned to Alarm 1-Pen 2 4=Assigned to Alarm 2-Pen 2 5=Assigned to Output 1-Pen 1* 6=Assigned to Output 2-Pen 1* 7=Assigned to Output 1-Pen 2* 8=Assigned to Output 2-Pen 2*	<b>0</b>	
35	Relay B Assignment	<b>rLyb</b>	Same selection as <b>rLyA</b>	<b>0</b>	
36	Relay C Assignment	<b>rLyC</b>	Same selection as <b>rLyA</b>	<b>0</b>	
37	Relay D Assignment	<b>rLyd</b>	Same selection as <b>rLyA</b>	<b>0</b>	
38	Current Output A Assignment	<b>CurA</b>	0 to 6 0=Not Assigned 1=Assigned to Process Value Output-Pen 1 2=Assigned to Process Value Output-Pen 2 3=Assigned to Output 1-Pen 1* 4=Assigned to Output 2-Pen 1* 5=Assigned to Output1-Pen 2* 6=Assigned to Output 2-Pen 2*	<b>0</b>	
39	Current Output B Assignment	<b>Curb</b>	Same selection as <b>CurA</b>	<b>0</b>	
40	Current Output A Range	<b>CoAr</b>	0 to 1 0=0-20 mA 1=4-20 mA	<b>1</b>	
41	Current Output B Range	<b>Cobr</b>	Same selection as <b>CoAr</b>	<b>1</b>	
42	Chart Rotation Time	<b>Crt</b>	0.1 to 999.9 hours per rotation	<b>1.0</b>	
43	Pen Action on Power Up	<b>PAPu</b>	0=Pen(s) go to the "home" position (toward chart center) when powered up 1=Pen(s) remain in last position prior to power down	<b>0</b>	

STEP	DESCRIPTION	DISPLAY CODES	AVAILABLE SETTINGS	FACTORY SETTING	YOUR SETTING
44	Chart Operation in Off Mode	Coo	0 to 1 0=Chart continues rotating in the Off mode 1=Chart stops rotating while in the Off mode	0	

**COMMUNICATIONS OPTIONS PARAMETERS**

45	Communication Configuration	CCon	0 to 4 0=Off 1=Monitor Mode (Read Only) 2=Normal Mode (Read and Write) 3=Total Access with Limit Checking 4=Total Access without Limit Checking	3	
46	Communication Bit Rate Selection Will not be seen if CCon=0	CbS	1 to 6 1=300 2=600 3=1200 4=2400 5=4800 6=9600	6	
47	Communications Address-Pen 1 Will not be seen if CCon=0	CAd1	0 to 99	1	
48	Communications Address-Pen 2 (If provided) Will not be seen if CCon=0	CAd2	0 to 99	2	

## ALARM SET MODE FLOW CHART (APPLIES TO RECORDERS)

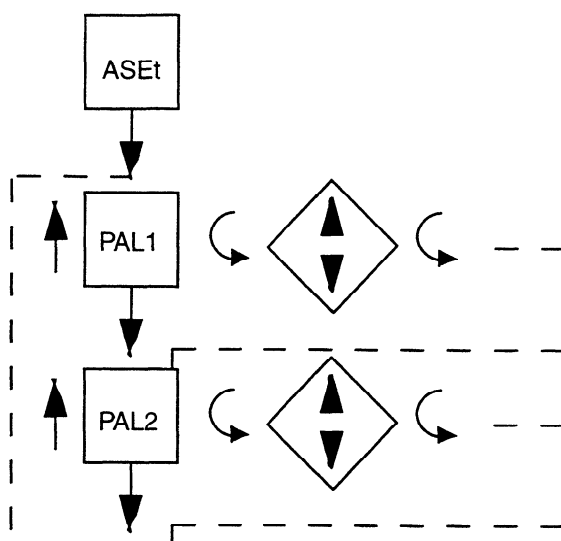

### Key

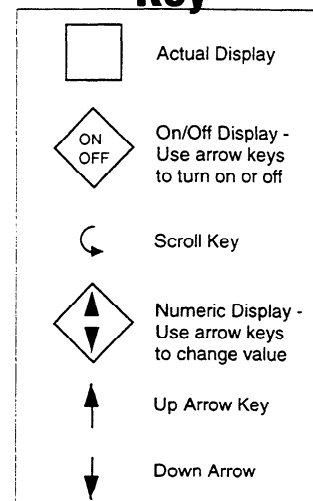

**TABLE 3-3 ALARM SET MODE CONFIGURATION PROCEDURE**

Press and release the SCROLL key until **ASet** is displayed, then press the DOWN key. Press the SCROLL key to advance the display through the parameters and their values. Use the UP and DOWN keys to select (adjust) the values. After selecting a parameter, press the SCROLL key to proceed to the next parameter. Pen 1 selections will appear in the Pen 1 window and the Pen 2 (if provided) selections will appear in the Pen 2 window. After all selections have been made, press the UP key with a parameter in the display (not a setting) to exit the mode.

STEP	DESCRIPTION	DISPLAY CODE	AVAILABLE SETTINGS	FACTORY SETTING	YOUR SETTING
1	Process Alarm 1	PAL1	-9999 to 9999 degrees/units	0	
2	Process Alarm 2	PAL2	-9999 to 9999 degrees/units	0	

If **ASet** does not appear on the display refer to the Enable mode section of this manual for directions on how to determine if the **ASet** mode is enabled. If **ASet** appears on the display, but pressing the DOWN key causes the display to change to **oFF**, this indicates that no alarm(s) have been selected in the Program mode.

### ALARM OPERATION

There are two types available per pen, Process Direct or Process Reverse. These are selected in the Program mode.

Process Alarm Direct - the alarm will be ON if the process value is greater than the process alarm value selected in the Alarm Set mode.

Process Alarm Reverse - the alarm will be ON if the process value is less than the process alarm value selected in the Alarm Set mode.

The alarms will be active while the instrument is in the Operate mode.

Alarm output chatter can be reduced by using the hysteresis (adjusted in Program mode) to create a deadband around the alarm point.

### LIMIT SETPOINT OPERATION

The instrument must be in the Operate mode to allow setpoint value to be displayed and adjusted. In the Operate mode, to view the setpoint, press and release the UP or DOWN key. The displayed value is the setpoint. To change the setpoint value, press and hold the appropriate key. Press and hold the UP key to increase the setpoint or press and hold the DOWN key to decrease the setpoint. The setpoint will change slowly at first then faster as the key is held.

To reset the limit output, press the RESET key after the limit condition has been cleared.

**NOTE:** The setpoint cannot be changed if the Limit setpoint has been exceeded.

### TUNE MODE FLOW CHART (APPLIES TO RECORDING CONTROLLERS)

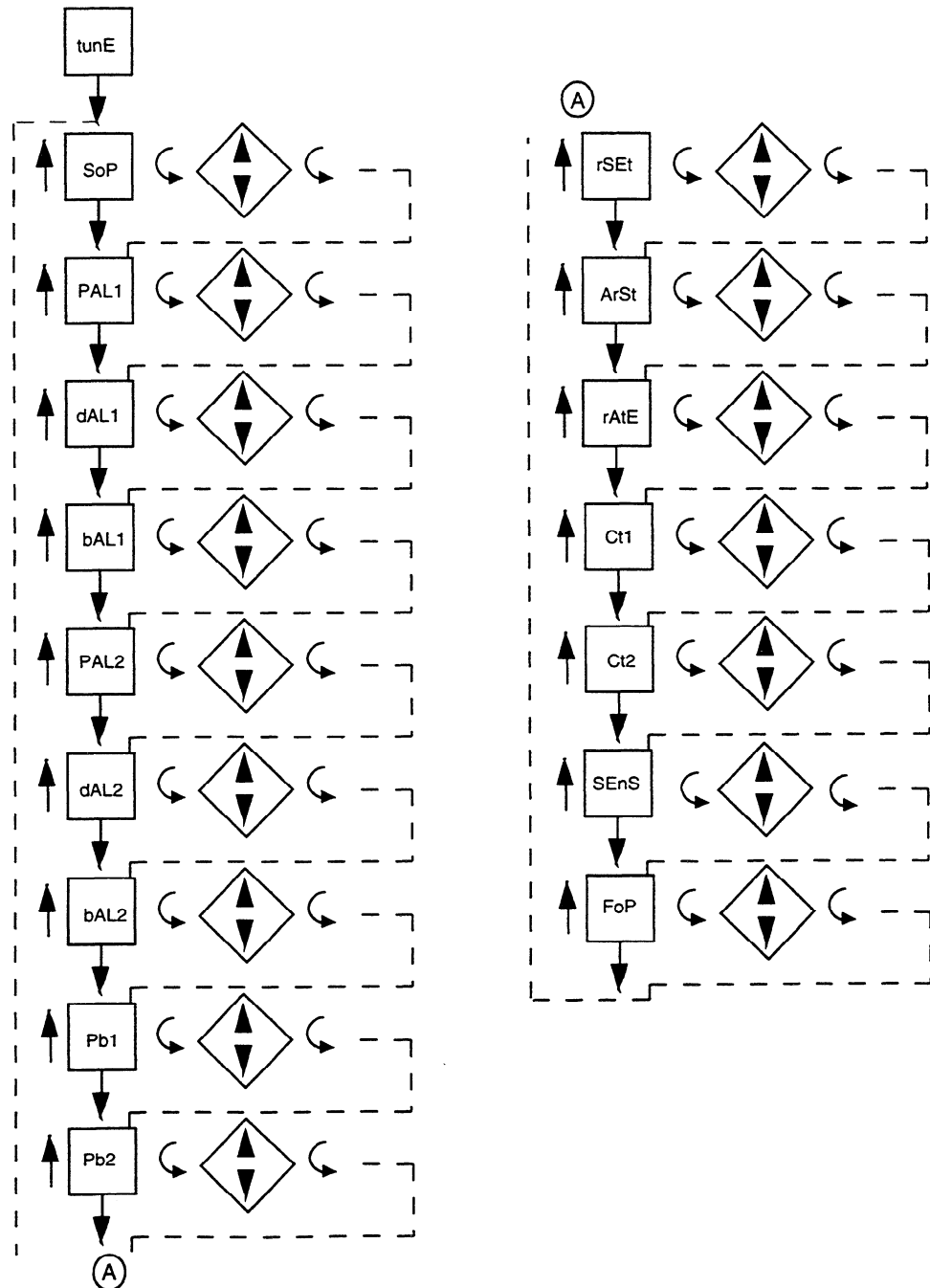

## TABLE 3-2 TUNE MODE CONFIGURATION PROCEDURE (APPLIES TO RECORDING CONTROLLERS)

The Tune mode allows the entry, review or altering of the process control Tune adjustments and alarm setting(s).

To enter the Tune mode, press and release the SCROLL key until **tunE** is displayed, then press the DOWN key. Press the SCROLL key to advance the display through the parameters and their values. Use the UP and DOWN keys to select (adjust) the values. Each time the DOWN key is pressed while a parameter code is being displayed, such as **SoP**, the next parameter code in the sequence will be displayed (**PAL1**).

After selecting a parameter, press the SCROLL key to proceed to the next parameter. Pen 1 selections will appear in the Pen 1 window and the Pen 2 ( if provided) selections will appear in the Pen 2 window after the Pen 1 parameters have been displayed. After all selections have been made, press the UP key with a parameter in the display (not a setting) to exit the mode.

For illustration purposes, all available Tune mode parameters have been listed. The parameters that will appear on the specific instrument will depend upon the parameter selections previously made in the Program mode.

For future reference, record the parameter selections for the application in the "Your Setting" column and on the Software Reference Sheet in Appendix E (page 72). Use the Software Reference Sheet to program the instrument.

To prevent unauthorized changes to the Tune mode, the mode can be disabled (turned off) in the Enable mode.

*The Tune mode is adjusted on-line. The instrument will react to changes as they are made.*

STEP	DESCRIPTION	DISPLAY CODES	AVAILABLE SETTINGS	FACTORY SETTING	YOUR SETTING
1	Second Output Position (Will not be seen if <b>out2=0,7</b> )	<b>SoP</b>	-1000 to 1000 units	<b>0</b>	
2	Process Alarm 1 (The Alarm setting seen will depend upon the Alarm selected in the Program mode)	<b>PAL1</b>	-9999 to 9999 units	<b>0</b>	
3	Deviation Alarm 1	<b>dAL1</b>	-3000 to 3000 units	<b>0</b>	
4	Deviation Band Alarm 1	<b>bAL1</b>	1 to 3000 units	<b>1</b>	
5	Process Alarm 2	<b>PAL2</b>	-9999 to 9999 units	<b>0</b>	
6	Deviation Alarm 2	<b>dAL2</b>	-3000 to 3000 units	<b>0</b>	
7	Deviation Band Alarm 2	<b>bAL2</b>	1 to 3000 units	<b>1</b>	
8	Proportional Band Output 1 (Will only be seen if <b>out1=3,4,5,6,7</b> )	<b>Pb1</b>	1 to 3000 units	<b>100</b>	
9	Proportional Band Output 2 (Will only be seen if <b>out2=3,4,5,6</b> )	<b>Pb2</b>	1 to 3000 units	<b>100</b>	
10	Manual Reset (Will only be seen if <b>Pb1/Pb2</b> were shown)	<b>rSEt</b>	-1500 to 1500 units	<b>0</b>	

<b>STEP</b>	<b>DESCRIPTION</b>	<b>DISPLAY CODES</b>	<b>AVAILABLE SETTINGS</b>	<b>FACTORY SETTING</b>	<b>YOUR SETTING</b>
11	Automatic Reset Integration (Will be seen if <b>Pb1</b> or <b>Pb2</b> was shown)	<b>ArSt</b>	0.0 to 100.0 repeats per minute	<b>0.0</b>	
12	Rate Derivative (Will be seen if <b>Pb1</b> or <b>Pb2</b> was seen)	<b>rAtE</b>	0.0 to 10.0 minutes	<b>0.0</b>	
13	Cycle Time Output 1 (Will be seen if <b>out1</b> =3,4,7)	<b>Ct1</b>	1 to 240 seconds	<b>30</b>	
14	Cycle Time Output 2 (Will be seen if <b>out2</b> =3,4)	<b>Ct2</b>	1 to 240 seconds	<b>30</b>	
15	Position Proportioning Sensitivity (Will be seen if <b>out1</b> =7 and/or <b>out2</b> =0,7)	<b>SEnS</b>	0.0 to 50.0 percent	<b>1.0</b>	
16	First Output Position	<b>FoP</b>	-1000 to 1000 units	<b>0</b>	

### TABLE 3-3 ENABLE MODE CONFIGURATION PROCEDURE

To enter the Enable mode, press the UP and DOWN keys while in **OPER**, **Ctrl**, or **oFF** modes. All the display lamps will light. After 2 seconds, the display will show **Cchg** and the pen(s) will move to and remain at a point above the top graduation on the chart. Continue to press the UP and DOWN keys, after 2 additional seconds, the display will show **P dn** and the Pen(s) are driven below the bottom graduation on the chart. After 6 more seconds, the display will show **EnAb**. Release the keys and the display will change to **EtSt**. Press and release the DOWN key and each mode to be enabled/disabled will be displayed. With the enable mode prompt for the desired mode displayed press the SCROLL key to verify that the displayed mode is either **on** (enabled) or **oFF** (disabled). Press the DOWN key to turn off the mode, press the UP key to turn on the mode or press the SCROLL key to advance the display to the next enable mode prompt. Use the "Your Setting" column in the table to record your settings.

A hardware jumper located on the Processor Board (See Appendix A-1, Page 62) can be used to lock/unlock the Enable mode. When the jumper is moved to the locked position, entry into the Enable mode is not possible until the jumper is moved to the unlocked position.

DESCRIPTION	DISPLAY CODES	AVAILABLE SETTINGS	FACTORY SETTING	YOUR SETTING
Test Mode	<b>EtSt</b>	on or oFF	<b>oFF</b>	
Calibration Mode	<b>ECAL</b>	on or oFF	<b>oFF</b>	
Program Mode	<b>EPro</b>	on or oFF	<b>on</b>	
Alarm Set Mode*	<b>EASt</b>	on or oFF	<b>on</b>	
Tune Mode**	<b>Etun</b>	on or oFF	<b>on</b>	
Manual (Stby) Mode**	<b>ESby</b>	on or oFF	<b>on</b>	
Setpoint Select mode** (Optional)	<b>ESPS</b>	on or oFF	<b>on</b>	
Setpoint Change***	<b>ESPC</b>	on or oFF	<b>on</b>	

\* RECORDERS

\*\* RECORDING CONTROLLERS

\*\*\* LIMITS OR RECORDING CONTROLLERS

## ENABLE MODE FLOW CHART

### RECORDERS

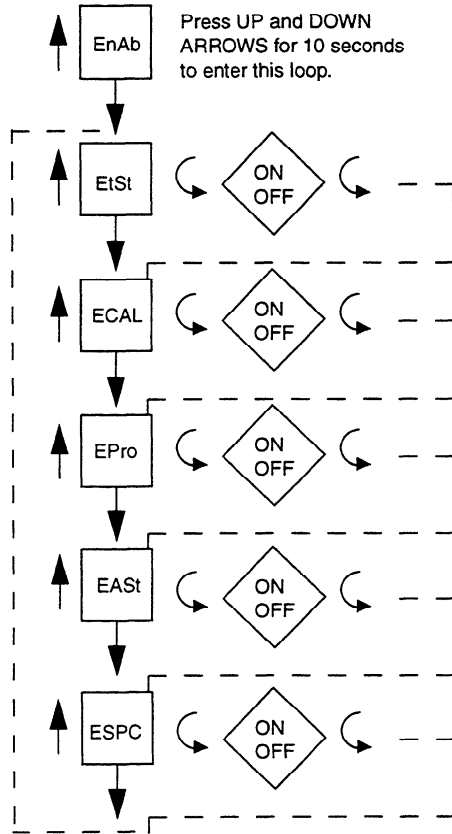

### RECORDING CONTROLLERS

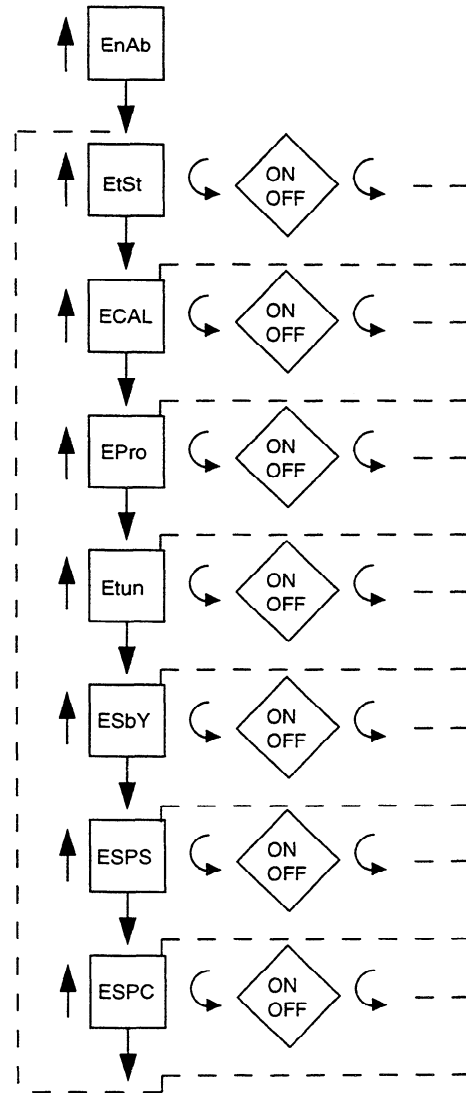

### Key

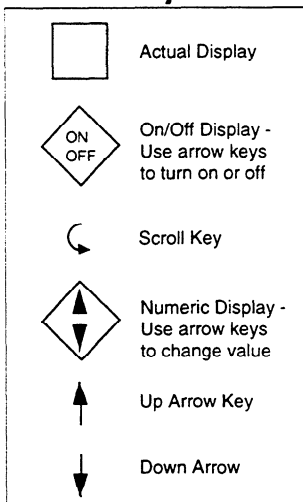

---

# Operation 4.1

---

## 4.1.1 OFF MODE

In the Off mode, the instrument control and alarm function (s) are turned off. Process Retransmission signal(s) remain active. The chart rotation can be selected in the Program mode to stop or continue to rotate when the instrument is in the Off mode. The pen(s) will remain active. The Off mode can be entered by pressing and releasing the SCROLL key until the display reads **oFF**, then pressing the DOWN key. The display will read **oFF** and then current process variable at two second intervals. Entering the Off mode of a dual pen instrument will cause both pens to enter the Off mode. The second pen display will be blank as the left display reads **oFF** and displays the process value for the second pen at the same time as the left display.

---

## 4.1.2 CONTROL MODE (APPLIES TO RECORDING CONTROLLERS)

In the Control mode, the instrument control function(s) and alarm(s) are actively responding to the process variable as selected in the Program and Tune modes and the chart will be rotating at the rate selected. The Control mode allows setpoint changes from either local setpoint (standard) adjustment by an operator at the front keypad or from remote setpoint source (optional). Other operations in the Control mode include a lamp test and proportional output display.

### 4.1.2.1 LOCAL SETPOINT OPERATION

Single Pen Instruments: The instrument must be in the Control mode to allow setpoint value to be displayed and adjusted. In the Control mode, to view the setpoint, press and release the UP and DOWN key. The green LED under the SP label will light to indicate that the displayed value is the setpoint. To change the setpoint value, press and hold the appropriate key. Press and hold the UP key to increase the setpoint or press and hold the DOWN key to decrease the setpoint. The setpoint will change slowly at first, then faster as the key is held. If the setpoint will not increase, check the Program mode to see that you are not trying to increase the setpoint above the setpoint upper limit **SPuL**. If the setpoint will not decrease, check the Program mode to see that you are not trying to decrease the setpoint below the setpoint lower limit **SPLL**. If the setpoint will not increase or decrease, check that the Setpoint Change mode is On in the Enable mode.

Dual Pen Instruments: The setpoint of each instrument can be reviewed separately. Pen 1: To review and change the local setpoint for Pen 1, press the UP key. The green LED in the upper display will light indicating that the setpoint value is displayed. The setpoint can now be raised by pressing and holding the UP key or decreasing by pressing the DOWN key. Pen 2: The setpoint for Pen 2 is viewed and changed in the same manner, except the DOWN key must be pressed to access the Pen 2 setpoint. The setpoint will change slowly at first, then faster as the key is held. If the setpoint will not increase, check the Program mode to see that you are not trying increase the setpoint above the setpoint upper limit **SPuL**. If the setpoint will not decrease, check the Program mode to see that you are not trying to decrease the setpoint below the setpoint lower limit **SPLL**. If the setpoint will not increase or decrease, check that the Setpoint change mode is On in the Enable mode.

### 4.1.2.2 REMOTE SETPOINT OPERATION

Single Pen Instruments: If the instrument is specified and provided with Remote Setpoint capability (auxiliary input of 0-5VDC or 1-5VDC), and the Remote Setpoint has been properly configured in the Program mode, the Setpoint Select mode will be accessible, if enabled. Press and release the SCROLL key until **SPS** appears in the display, then press the DOWN key. The display will show **Loc** if the local (keypad entered) setpoint is being used or **rSP** if the remote setpoint is in use. Press the SCROLL key to select the setpoint mode that will be used by the instrument. Press the UP key to exit the Setpoint Select mode.

**Dual Pen Instruments:** If the instrument is specified and provided with the Remote Setpoint capability for either or both pens and the Remote Setpoint has been properly configured in the Program mode for either or both pens, the Setpoint Select mode will be accessible, if enabled. Press and release the SCROLL keys until **SPS** appears in the display, then press the DOWN key. The left display will light and the upper display will blank if pen 1 is selected for a remote setpoint. If only pen 2 is selected as a remote setpoint, then the left display will blank and the right display will light. If both pens are selected for remote setpoint, the right display is accessed by pressing the DOWN key while the left display shows the setpoint mode selected for that pen. The display(s) will show **Loc** if the local (keypad entered) setpoint is being used or **rSP** if the remote setpoint is in use. Press the SCROLL key to select the setpoint mode that will be used by the instrument. Press the UP key to exit the Setpoint Select mode. If a problem develops with the remote setpoint signal for either pen, the left display will show **rSEr**, the remote setpoint error code.

Digital Communications: The setpoint can be adjusted from a supervisory computer system. Dual pen instruments are capable of having independent setpoint adjustments for each pen.

### SETPOINT SELECT FLOW CHART (APPLIES TO RECORDING CONTROLLERS)

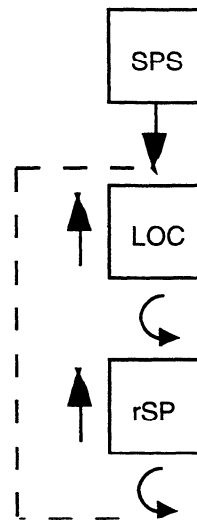
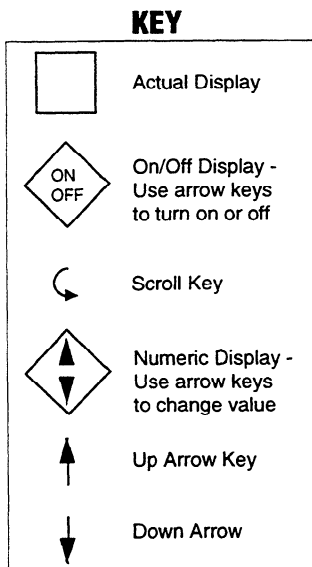

#### 4.1.2.3 ON-OFF CONTROL

On-Off control can only be implemented on controllers provided with SPST relay or SSR driver output's. On-Off operation can be assigned to either or both output 1 and 2 for each pen. The On-Off control can be selected as direct or reverse acting. Direct action is typically used in cooling applications. The output device will turn On when the process value is greater than the setpoint. Reverse action is typically a heating application. The output device will turn On if the process value is below the setpoint. A hysteresis adjustment is provided for On-Off outputs on each pen. This adjustment is in terms of degrees/engineering units and defines the width of the hysteresis band about the setpoint. This parameter may also be referred to as a deadband. Relay chatter can be eliminated by proper adjustment of this parameter. When operating in On-Off control, the control algorithm will turn the output On or Off depending upon the setpoint, the relative position of the process value, and the hysteresis adjustment. The respective OUT1 or OUT2 indicator for the respective pen will illuminate to indicate that the output device is On.

#### 4.1.2.4 TIME PROPORTIONING CONTROL

Time Proportioning Control can be implemented on controllers provided with SPST relay or SSR driver output(s). Time proportioning can be programmed for output 1 and/or 2 for each pen. Time proportioning control is accomplished by cycling the output On and Off when the process value is within the proportional bandwidth selected at a prescribed time period. The time period is selected in the Tune mode by adjusting **Ct1** and/or **Ct2**. The On time is a percentage of the Cycle Time.

Example: Calculated output % = 40%;      Cycle Time adjustment = 20 seconds  
Output On Time = .4 x 20 = 8 seconds  
Output Off Time = .6 x 20 = 12 seconds

#### 4.1.2.5 CURRENT PROPORTIONING CONTROL

Current Proportioning control provides a proportional current output in response to process value and setpoint. The current output can be selected for direct or reverse operation. Direct current output control is typically used for cooling applications. The current output will increase as the process value increases within the proportional bandwidth selected. The reverse current output control is typically used in heating applications. The current output will decrease as the process value increases within the proportional bandwidth selected.

The instrument can be programmed to provide 0 to 20mADC or 4-20mADC current output(s). The output selected is dependent upon the final control element being used in the process. The output 1 and/or output 2 LED will be lighted whenever the Current Proportional outputs are selected.

#### 4.1.2.6 POSITION PROPORTIONING CONTROL

Position Proportioning control can be implemented on those controllers provided with two SPST relay outputs or two SSR Driver outputs and Slidewire Feedback option for the respective pen. This control implementation can be performed on each pen.

Position proportioning control permits the use of PID control where the final control element is a modulating device such as a motorized valve. In this form, each of the two required relays or SSR Drivers will be used to control the valve. One output will be used to open the valve, the other is used to close the valve. The slidewire feedback is used to provide a signal relative to the valve armature position to the instrument.

As with the other proportioning control forms, the process input, tuning parameters and the setpoint are used by the control algorithm to calculate the output % required to correct for the deviation between setpoint and process.

Proportional Output 1 Action **P1EC** on error condition does not apply to position proportioning control. In an error condition, the unit goes only to 0% output (fully closed).

With Position Proportioning control, it may be necessary to adjust the Sensitivity Tune **SEnS** mode parameter to reduce or eliminate oscillations of the motor around setpoint. If oscillation occurs, increase the **SEnS** value until the motor stops oscillating. If the differential between the Open and Closed rotation is too large, then decrease the **SEnS** value. Also, for proper Position Proportioning operation, it is necessary to specify the actuation time of the valve or damper from full open to full closed. If the motor has a stroke duration of 60 seconds, change the value in the Cycle Time parameter **Ct1** to 60. This ensures that controller will move the motor for the proper amount of time when making adjustments.

#### 4.1.2.7 PROPORTIONAL OUTPUT PERCENTAGE DISPLAY

While in the Control mode, pressing the UP and the SCROLL keys at the same time will cause the display to sequence through a series of display codes and values:

<b>Po1</b>	Percent Output (if applicable)	Output 1% value
<b>Po2</b>	Percent Output (if applicable)	Output 2% value
<b>Proc</b>	Process Value	Actual Process Value

Each code and output value will be displayed only if the corresponding proportional output is present. Each code or value will be displayed for 1 second. This sequence of displays will continue until the SCROLL key is pressed, which will then return the display to the normal mode. Displays will be sequenced for both Pen 1 and 2 as applicable on dual pen instruments.

### 4.1.3 MANUAL MODE FOR PROPORTIONAL OUTPUTS (APPLIES TO RECORDING CONTROLLERS)

Manual adjustment of the proportional output(s) can be used to test the operation of the output(s), while tuning to establish basic process control, or to provide control of the proportional output(s) during the occurrence of certain error conditions.

**Note:** The proportional outputs do not change automatically in response to changes in the process while in the Manual mode. Be sure to pay close attention to the process to avoid damage.

To enter the Manual mode, press and release the AUTO/MAN key for the specific pen. If the Standby mode is On in the Enable mode and a control output is selected for proportional control, the instrument will enter the Manual mode. The Manual mode status LED will light for that pen to indicate that the Manual mode is in use. Shifting from the Control to the Manual mode is bumpless. The proportional output(s) will stay at the last value(s) calculated by the control algorithm. **Po1** will appear on the display if output 1 is a proportional output or **Po2** if output 2 is not a proportional control.

In order to vary a proportional output value, press and release the SCROLL key until the display code for the output is displayed, **Po1** or **Po2**. Press the SCROLL key again to see the percentage of output value. Press the UP key to increase the output percentage value. Press the DOWN key to decrease the output percentage value.

If no keys are pressed, the display will sequence through the following displays:

**Po1** if output 1 is 3, 4, 5, 6, 7 then the output 1 percentage of output value

**Po2** if output 2 is 3, 4, 5, 6, 7 then the output 2 percentage of output value

**Proc** will be displayed then current process value for that pen

In order to change a proportional value once the cyclic display begins, press and release the UP or DOWN key then press the SCROLL key until the display code for the output displayed is **Po1** or **Po2**. Press the SCROLL key again to see the percentage of output value. Press the UP key to increase the output percentage value. Press the DOWN key to decrease the output percentage value.

To return to the Control mode of operation from the Manual mode, press the specified AUTO/Man key. If the Automatic Transfer feature is selected in the Program mode, the instrument will switch from Manual mode to the Control mode when process value reaches the setpoint value.

## STANDBY MODE FLOW CHART (APPLIES TO RECORDING CONTROLLERS)

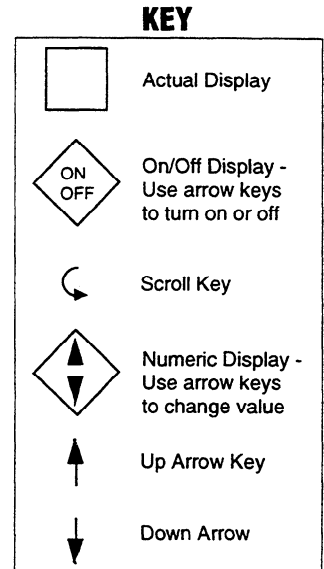
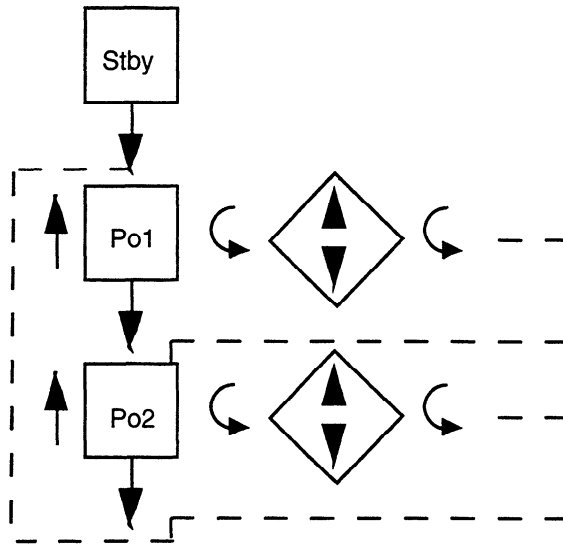

## Alarm Operation 4.2

There are two alarms available per pen. The type of alarm is selected in the Program mode as follows:

1. Process Alarm Direct - the alarm will be On if the process value is greater than the process value selected.
2. Process Alarm Reverse - the alarm will be On if the process value is less than the process value selected.
3. Deviation Alarm Direct\* - the alarm will be On if the process value is greater than the setpoint plus the deviation value selected.
4. Deviation Alarm Reverse\* - the alarm will be On if the process value is less than the setpoint plus the deviation value selected.
5. Deviation Band Alarm Open Within\* - the alarm will be On if the process value is greater than one half the deviation band alarm values selected above or below the setpoint.
6. Deviation Band Alarm Close Within\* - the alarm will be On if the process value is less than one half the deviation band value selected above or below the setpoint.

### \* Applies to Recording Controllers

The alarms will be active while the instrument is in the Operation mode (Recorder) or Control mode (Recording Controller). Relay and solid state relay drivers can be assigned to provide output capability for the alarm functions.

The alarm value (Process, deviation, or bandwidth) is selected in the Alarm Set mode (Recorder) or Tune mode (Recording Controller).

Alarm outputs chatter can be reduced by using the hysteresis for the alarm output adjustable in the Program mode to create a deadband around the alarm point.

---

## **Tune Mode Operation 4.3 (Applies to Recording Controllers)**

Proportional output controllers may require the adjustment (tuning) of the PID and other related parameters. This provides a means for the instrument's control algorithm to be adjusted to meet specific application requirements.

---

### **4.3.1 SYSTEMATIC TUNING METHOD**

1. Changes in tuning parameters should be made one at a time.
2. After making any changes in tuning parameters, a disturbance should be introduced into the process so that the process reaction may be observed. This process reaction, or recovery, will tell whether the tuning parameters provide the desired control. It is usually easiest to make a step change in setpoint to introduce this disturbance.
3. The change in setpoint or disturbance, referenced above should be large enough to cause an observable deviation of process from setpoint. However, this change should not be so large that it will cause the controller output to proceed to either extreme limit.
4. Controller tuning for optimal control is not hard and fast, **BE PATIENT**: The process will take a certain amount of time to react to the setpoint changes during tuning. The amount of time depends upon the specific process, however, a period of 8 to 12 minutes should be allowed between changes. The important point to remember is to allow the process to react completely, do not rush through tuning of the controller. If the complete process reaction is not observed, optimum control may never be achieved.
5. Time Proportioning control output(s) require the cycle time to be adjusted for the application. Short cycle times typically result in the most accurate process control, but will cause the quickest "wear out" of any mechanical components.
6. Leave all other tuning parameters (except for the alarm settings) at the factory default settings. Obtain the best possible process reaction by adjusting the Proportional Band width parameter. The setting that achieves the best response for the process should be left in the controller programming, and should be noted on the Software Reference Sheet in Appendix E (page 72).
7. If there are to be no setpoint or load changes in the process, the Proportional Band adjustment may be all that is necessary for proper control. If an offset still exists (the process does not settle out at setpoint for the best possible proportional band adjustment), Manual Reset may be added to eliminate this offset.
8. Auto Reset may be added to eliminate process offsets with respect to setpoint. Increase Auto Reset from 0 to 0.2 increments. Start with a small amount. Increase this increment if there is no apparent reaction. Remember to allow the process 8 to 12 minutes to react to any changes.
9. If necessary, Rate may be added. Rate is a dynamic tuning parameter. Rate may be required to compensate for load changes or to inhibit process oscillations that occur when a large amount of auto reset (4 or 5 repeats/minute) is being used.
10. Controller tuning is not hard and fast. It may be necessary to adjust the tuning parameters over a period of time to obtain optimal control of the process.

### 4.3.2 ZIEGLER NICHOLS TUNING METHOD

This procedure has been determined empirically to yield ideal 1/4 amplitude decay tuning parameters that are determined by watching the system in a sustained oscillation (curve C, page 44, the ultimate proportional band and ultimate time period) and then using these values from this sustained oscillation to calculate ideal parameters.

To aid in determining the process oscillation, the instrument configuration parameters can be adjusted. By reducing the chart upper value **Cru** and increasing the chart lower value **CrL**, the resolution of the oscillation can be better observed. Also the chart rotation time **Crt** can be reduced to improve the observation of the oscillation cycle time.

Determining Ultimate Proportional Band and Ultimate Time Period

1. Set Manual Reset **rSet** to 0.0, set **ArSt** to 0.0 and set **rAtE** to 0.0.
2. Enter the Control mode of operation, observe the process reaction.
3. Set the Proportional Band (PB) at 100 and upset the process and observe the response. One easy method for imposing the upset is to move the setpoint for a few seconds and then return it to its original value.
4. Achieve a response curve similar to the sustained oscillation (curve C), this is the Ultimate Proportional Band (UPB) and Ultimate Time Period (UTP).
  - a) If the response curve from step 3 does not damp out, as in curve A from the drawing, the PB is too low. The PB should be increased and step 3 repeated.
  - b) If the response in step 3 damps out, the PB is too high. The PB should be decreased and step 3 repeated.

These values obtained for Ultimate Proportional Band (UPB) and Ultimate Time Period (UTP) are used to calculate ideal P, PI, PD, PID tuning parameters using the following Ziegler-Nichols equations:

Proportional only control (P)	$P (\mathbf{Pb}) = 2 \times \text{UPB (degrees or units)}$
Proportional plus automatic reset (PI)	$P (\mathbf{Pb}) = 2.2 \times \text{UPB (degrees or units)}$ $I (\mathbf{ArSt}) = 1.2 / \text{UTP (repeats per minute)}$
Proportional-plus-derivative (or rate) (PD)	$P (\mathbf{Pb}) = 1.7 \times \text{UPB (degrees or units)}$ $D (\mathbf{rAtE}) = \text{UTP} / 8 \text{ (minutes)}$
Proportional-plus automatic reset-plus derivative (PID)	$P (\mathbf{Pb}) = 1.7 \times \text{UPB (degrees or units)}$ $I (\mathbf{ArSt}) = 2 / \text{UTP (repeats per minute)}$ $D (\mathbf{rAtE}) = \text{UTP} / 8 \text{ (minutes)}$

If an over damped response is desired, multiply the proportional band by two.

(Referenced illustration on next page)

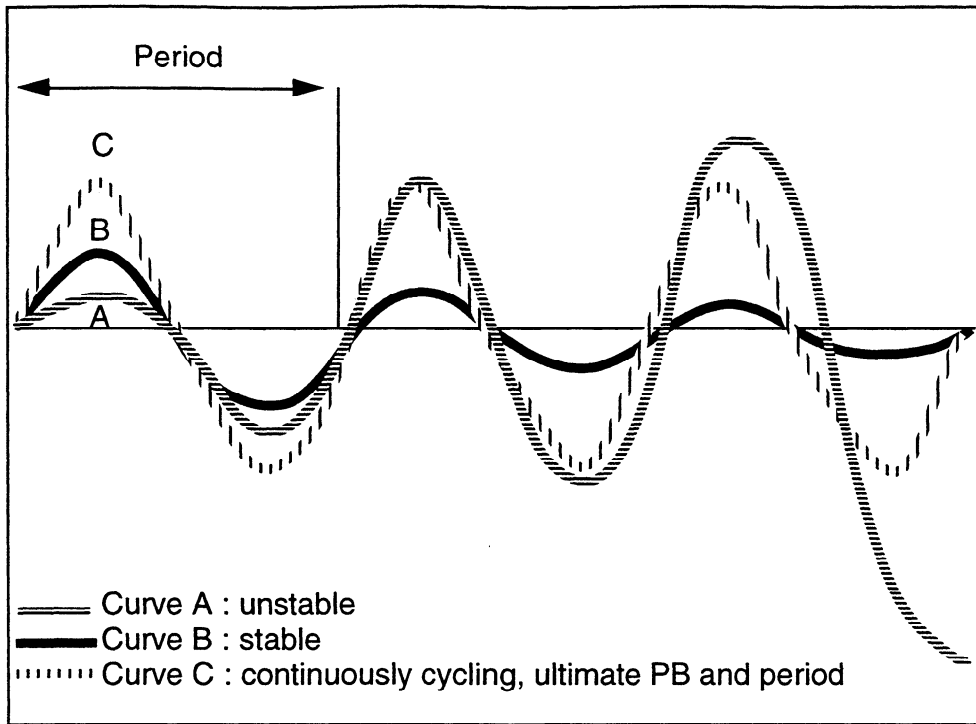

---

## Service 5.1

This section contains information regarding calibration and test procedures that can be performed in the field as well as items concerning the normal maintenance of the instrument.

---

## Changing Charts 5.2

Chart changes may be done while in the normal operating mode.

**CAUTION: The chart flange assembly pin is sharp to perforate the chart. Use caution while installing the chart to avoid coming into contact with the pin.**

1. Depress and hold the UP and DOWN keys for between 2 and 3 seconds. Immediately after depressing the keys, the unit will do a Lamp Test with all LED segments and indicators lighted on the upper (and lower) display.
2. After 2-3 seconds, the display will show **Cchg**, the pen(s) will move to and remain at a point above the top graduation on the chart and the chart will stop rotating. All other functions remain active (Control, Display, etc).
3. Open the instrument door, snap up the chart hold down lever on the chart flange assembly, gently lift the pen(s) and remove old chart.
4. With the pen(s) held up, install new chart. Be sure to line up the chart time line so that the current time is aligned with the time setting mark on the chart platen.
5. Snap down chart hold down lever and close the instrument door.
6. Depress and hold the UP and DOWN keys for between 2 and 3 seconds. Immediately after depressing the keys, the unit will do a Lamp Test with all LED segments and indicators lighted on the upper (and lower) display.
7. After 2-3 seconds, the display will show **Cchg** momentarily, then the pen(s) position and chart rotation will be restored.

---

## Changing Pens 5.3

Open the instrument door. Refer to Figure 5-1 for pen changing procedure. This procedure is also provided on a label on the instrument chart platen. Be sure to replace the pen cartridge with the same type (color) that was removed. Be careful not to bend the pen arm while changing the pen.

**FIGURE 5-1**  
Changing Pens

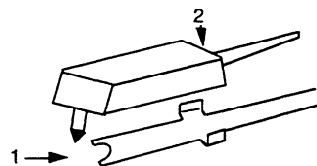

To install pen, slide pen into holder (1) and push down (2) as shown by arrows

For five replacement pens order:  
Green #60500401  
Red #60500402

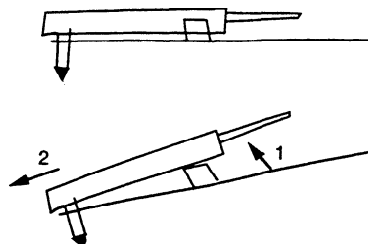

To remove pen for replacement, pull up at back end (1) and push out.

# Calibration 5.4

**CAUTION: Do not attempt any calibrations without the proper test equipment that meets or exceeds the specifications listed.**

Press and release the SCROLL key until **CAL** appears on the display, then press the DOWN key to enter the mode. The display will change to **CAL1**. Press the SCROLL key to advance the display to the other calibration modes available. For two pen units, **CAL5** will only need to be required on TB4 to calibrate Pen 1 and Pen 2 inputs. Both TB 4 and TB 5 inputs must be calibrated for thermocouple inputs. Table 5-1, page 47, provides a listing of field calibration routines. All instruments are calibrated prior to shipment from factory.

## CALIBRATION FLOW CHART

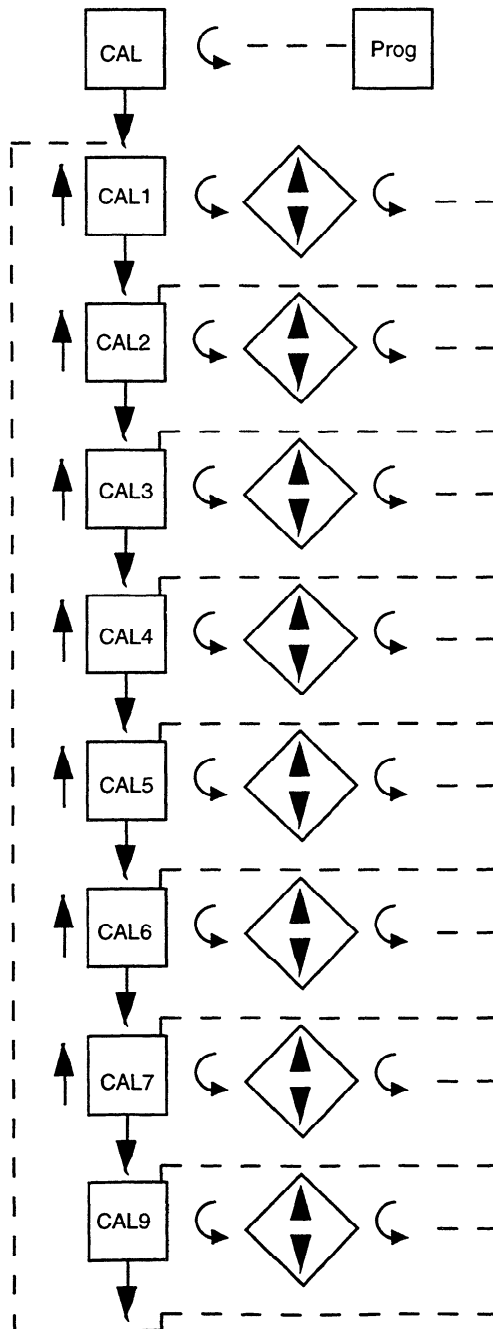
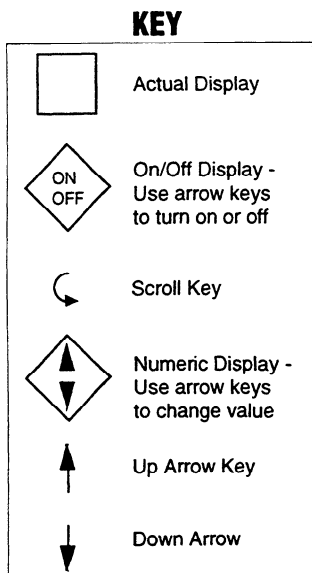

---

## TABLE 5-1 CALIBRATION PROCEDURES

Calibration Procedure	Description
CAL 1	Reinitialization of program and tuning values.
CAL 2	Main calibration necessary for all input types.
CAL 3	Cold Junction Compensation calibration used to correct for component variation in the CJC circuit. Necessary for thermocouple inputs.
CAL 4	Cold Junction Utility, displays temperature the cold junction compensator is sensing. No adjustment is made with this procedure.
CAL 5	RTD input calibration. Necessary to be performed on both terminal boards.
CAL 6	Cold Junction Compensation on/off. Used for validating thermocouple inputs with a millivolt source. (Non temperature compensating)
CAL 7	Factory use only.
CAL 9	Pen position calibration used to calibrate pens to chart.

---

### 5.4.1 CAL 1 PARAMETER RE-INITIALIZATION

This routine is used to clear all information in the Program and Tune modes. All parameters will be reset to default values. **Before performing this procedure, make sure that the Program and Tune values are written down so that they can be re-entered after Calibration 1 is completed. No test equipment required.**

With **CAL 1** displayed, while pressing the DOWN key, press the SCROLL key. The display will momentarily blank while the initialization is in progress. Upon completion of the routine, a Pen Home function is automatically performed; **P.dn** is displayed during this period, with the decimal point flashing to indicate this mode. Once the pen(s) reach Pen Home, **CAL1** will be displayed.

---

### 5.4.2 CAL 2 MAIN CALIBRATION

This routine determines and saves calibration values which correct for component variations relating to the basic measuring function of the unit. A 50.00 mVDC  $\pm$  .01mVDC source is required for testing. **Make sure that the Processor board jumpers JU4 and JU5 are in the non-volt positions. See Appendix A-1 (page 62) for proper positioning. After completing CAL2, be sure to re-position these jumpers to the appropriate position for your input.**

With **CAL 2** displayed, press and hold the DOWN key, then press the SCROLL key. Release the keys when the instrument displays **hLd1**. Short the input terminals or apply 0.00,  $\pm$ .01 mVDC to TB 4 terminals 1 and 2. Press the DOWN key and **dELy** will appear for 10 seconds, then **SCAn** will appear for 10 seconds. A calibration reference number will then appear, this should be 0  $\pm$  50. If this number falls outside these limits, press the SCROLL key and **CAL 2** will be displayed. Perform the calibration again. Repeat the calibration until the number falls within the tolerance limits. If the number remains outside the limits, check the connections and try the calibration again. If the number does not approach the tolerance limits contact the nearest representative or the factory for assistance. With an acceptable reference number on the display, remove the short and connect a 50.00,  $\pm$ .01 mVDC source to the TB 4 terminals 1 and 2. Be sure to observe the proper polarity when connecting the source. Terminal 1 is positive and terminal 2 is negative. Press the DOWN key, **deLy** will be displayed for 10 seconds and then **SCAn** for 10 seconds. When the calibration is complete **CAL 2** will reappear.

(Continued on next page)

Error recovery:

See section 5.6 (page 55) for details. Ensure that the millivolt source is connected correctly and functioning properly.

The calibration can be exited when **hLd1** or the calibration reference number is displayed by pressing the SCROLL key.

#### **CAL2 QUICK CALIBRATION**

This routine will allow the operator to execute a rough calibration on their unit via the keypad with no other equipment or disturbance to established wiring. It is intended to provide a partial recovery from a calibration corruption where the necessary equipment indicated may not be available. It should be noted that this is not intended as a substitution to the main calibration procedure described earlier and may considerably deter from the accuracy of the instrument.

With **CAL2** displayed, press and hold the DOWN ARROW key, then press the SCROLL key. Release both keys and the instrument will display **hLd1**. Press and hold the UP ARROW key, then press the SCROLL key. The display will momentarily blank and then **CAL1** will be displayed. Release both keys and depress the UP ARROW key. **CAL** will be displayed.

---

### **5.4.3 CAL 3 COLD JUNCTION COMPENSATION**

This routine determines and saves calibration values which correct for component variations relating to the cold junction compensation. This calibration must be preceded by **CAL 2** the main calibration, to properly calibrate the instrument. These two calibrations are all that is needed for proper operation with thermocouple inputs

Test equipment: 1-type J thermocouple  
1-mercury thermometer +/- .25 degrees F for equivalent  
Allow 30 minutes of warm up time for the instrument with the thermocouple connected before proceeding with calibration.

Operation:

With **CAL 3** displayed press and hold the DOWN key, then press the SCROLL key. The instrument will display **hoLd**. Release both keys. Press the DOWN key, **deLy** will be displayed for up to 10 seconds, then **SCAn** for 10 seconds. If **SCAn** remains in the display for much longer than ten seconds, refer to the note below. The instrument will compute and display the cold junction temperature to the nearest tenth of a degree C. Compare the display reading with thermometer and use the UP and DOWN keys to correct the reading. To exit, press the SCROLL key and **CAL 3** will be displayed again.

NOTE: If the display stays in **SCAn** for more than 10 seconds press the SCROLL key. **CAL3** should be displayed. With **CAL3** displayed, while pressing the DOWN key, press the SCROLL key. The instrument will display **hoLd**. Press the UP key. The instrument will begin the calibration procedure with a default value and proceed to **dELy** as described above.

Error recovery:

See section 5.6 (page 55) for details on specific errors. The calibration can be exited if **hoLd** or the CJC temperature is displayed by pressing the SCROLL Key.

---

### **5.4.4 CAL 4 COLD JUNCTION UTILITY**

This procedure displays the temperature the cold junction compensator is sensing. No test equipment is required.

With **CAL 4** displayed, press and hold the DOWN key, then press the SCROLL key. Release both keys and **SCAn** will be displayed for 10 seconds while the instrument senses the CJC temperature. The result will then be displayed to a tenth of a degree C. The input terminals must be shorted. **CAL 3** must first be performed. *The displayed temperature is not the ambient temperature. It is the temperature of the CJC.* To exit, press the SCROLL key and **CAL 4** will be displayed.

---

### 5.4.5 CAL 5 RTD INPUT

This procedure determines and saves calibration values relating to RTD inputs. This calibration must be preceded by **CAL 2** to properly calibrate the instrument. Both RTD inputs must be calibrated and both inputs must have valid inputs during the calibration. Decade boxes with .01% resolution or equivalent are required. **Make sure that the Processor board jumpers JU4, JU6 and JU5, JU7 are in the proper positions. See Appendix A-1 (page 62).**

With **CAL 5** displayed, press and hold the DOWN key and then press the SCROLL key. The display will now be **PEn1** to indicate that the instrument is set to calibrate the RTD input on TB 4. Press the DOWN key to change the display to **PEn2** to calibrate the RTD input at TB 5. Choose the input TB to be calibrated and press the SCROLL key, **hLd1** will then be displayed. Connect the decade box at 100 ohm setting across the input terminals 1 and 2 and a jumper wire from terminal 2 to 3. Press the DOWN key and **dELy** will be displayed for 10 seconds, then **SCAn** for ten seconds. When **hLd2** is displayed, change the decade box setting to 277 ohms to the input terminals (do not disturb the wiring) and press the DOWN key. The display will change to **dELy** for 10 seconds, followed by **SCAn** for ten more seconds. **CAL 5** will be displayed after the calibration is completed.

#### Error recovery:

See section 5.6 (page 55) for details on specific errors.

The calibration can be exited when the instrument displays **hLd1** by pressing the SCROLL key.

---

### 5.4.6 CAL 6 COLD JUNCTION UTILITY

This routine provides selection of operating modes for the cold junction compensation used for thermocouple inputs.

With **CAL 6** displayed, press and hold the DOWN key, then press the SCROLL key. The instrument will display **C6** and the number of the mode in effect. Press the UP or DOWN key to change the mode selection, indicated by the number to the right of the **C6**. Pressing the SCROLL key will exit the calibration with the last mode number displayed in effect.

The selected mode will remain in effect if power is interrupted. To return the instrument to normal operation, **CAL 6** must be exited, with mode zero selected, or **CAL 1** must be executed to initialize all parameters.

Mode 0: Normal operating mode.

Mode 1: Cold Junction Compensation temperature will be internally fixed at 0 degrees C by the software to facilitate linearization testing when using an uncompensated millivolt source to simulate the thermocouple millivolt input signal.

---

### 5.4.7 CAL 9 PEN CALIBRATION

This procedure is used to calibrate the pen(s). No special test equipment required.

Valid inputs must be connected to TB 4 and TB 5 before performing this calibration. With **CAL 9** displayed, push and hold the DOWN key, then press the SCROLL key. Release both keys and the display will indicate **PEn1**. For 2 Pen instruments, press the DOWN key to toggle the display between pen 1 and pen 2. With desired pen displayed, press the SCROLL key.

**P.dn** will be displayed while the selected pen is moved to its "HOME" position (toward the chart hub) with the decimal point flashing to indicate this mode. Once "Pen Home" is found, the pen will move to the inner ring and **PEnL** will be displayed. At this point, one of two adjustments may be made; Pen Arc or Zero and Span.

Pen Arc - To adjust the pen arc, the UP and DOWN keys are pressed simultaneously to draw an arc for visual reference. The display will show **P uP** while the selected pen moved upscale to the top stop position. The pen then moves back downscale to nominally place the pen at the outer ring (100%) of the chart. The display will now display **ArC**. The pen arm may be loosened and the length adjusted to a position and angle to place the pen tip near the outer ring then re-tighten the pen arm. Press any key and the pen will drive to "HOME", then back to the inner ring (0%) and **PEnL** will be displayed.

Zero and Span - To begin a pen zero, with **PEnL** in the display, the UP or DOWN key may be pressed to move the pen to the low end of the chart span (0%). When adjusted, press the SCROLL key and **P uP** is displayed while the pen is moved to the outer edge (100%) of the chart, then **PEnh** is displayed. To adjust pen span, use the UP and DOWN keys to adjust the pen for the high end (100%) of the chart. When adjusted, press the SCROLL key and **P dn** will be displayed for about 5 seconds while the pen is moved to the 50% point on the chart, then **PEn1** is displayed. Calibration may now be performed again to verify the accuracy, or press the UP key twice to exit back to the CAL mode.

## Test Mode 5.5

To enter the Test mode, press and release the SCROLL key until **tESt** appears on the display then press the DOWN key. **tSt1** will be displayed, press and release the SCROLL key to advance the display to the desired test. Tests 1, 2 and 3 are performed as a unit so the display will advance directly to **tSt4** from **tSt1**. Listed in Table 5-2, page 52, are the test procedures available. Test 1, 2 and 3 are performed on start up, periodically during operation, and on entry into the Test mode. Test 4 is executed on entry into and periodically during the Operation mode. These tests can be used as a trouble shooting aid.

### TEST MODE FLOW CHART

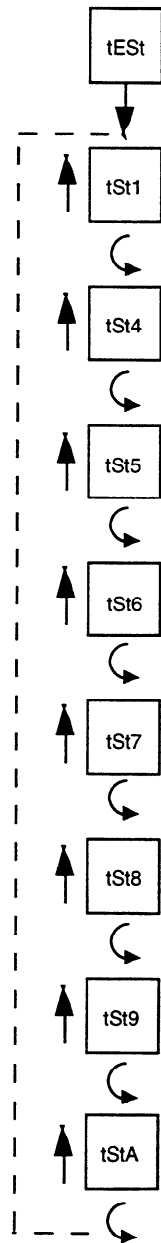

#### KEY

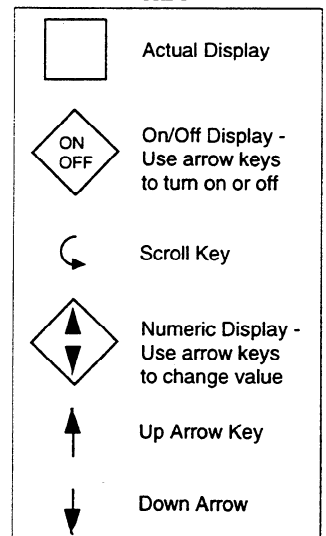

---

**TABLE 5-2 TEST PROCEDURES AND DESCRIPTION**

<u>Test</u>	<u>Description</u>
Test 1	Microprocessor internal RAM test. Used to check the processor RAM to make sure it is functioning correctly.
Test 2	External RAM test, used to test the RAM chip for proper function.
Test 3	EPROM checksum test, used to check that the EPROM program is correct.
Test 4	External RAM checksum test; instrument test and identifies how many times Errors 16 or 17 have occurred.
Test 5	Verifies that all keys are functional and all LEDs are working.
Test 6	Used to verify that all relays and solid state relay driver outputs are working correctly.
Test 7	This procedure will allow operator to adjust the current output value to check the output and to test the operation of the external device.
Test 8	Pen and chart motor operational check.
Test 9	Verifies that the auxiliary inputs are functioning properly.
Test A	Communications Hardware Test.

---

**5.5.1 TEST 1 INTERNAL RAM TEST**

Tests the Random Access Memory internal to the microprocessor. No special test equipment is required.

With **tSt1** displayed, press and hold the DOWN key, then press the SCROLL key. **tSt1** will be displayed momentarily while the test is in progress. Upon successful completion, the instrument will proceed to Test 2.

---

**5.5.2 TEST 2 EXTERNAL RAM TEST**

Tests the battery backed-up RAM external to the microcomputer. No special test equipment is required.

After completion of Test 1, **tSt2** will be displayed momentarily while the test is in progress. Upon successful completion, the instrument will proceed to Test 3.

---

**5.5.3 TEST 3 PROGRAM EPROM TEST**

This is a checksum test to verify data integrity of the stored program. No special test equipment is required.

After completion of Test 2, **tSt3** will be displayed momentarily while the test is in progress. Upon successful completion of Test 3 **tst1** will be displayed.

---

**5.5.4 TEST 4 EXTERNAL RAM CHECKSUM TEST**

This is a checksum test to verify the integrity of data stored in RAM and indicate the number of times the instrument has had an Error 16 or 17. The unit may have automatically recovered from these errors. No special test equipment is required.

With **tst4** displayed, press and hold the DOWN key then press the SCROLL key. The display will blank momentarily, then momentarily display two numbers, and then **tst4** will be displayed. These numbers indicate the number of times Error 16 and 17 have occurred respectively. Test 4 can be executed again, or another test may be selected.

*Test 4 can be used to display the line frequency determined at power-up. With tSt4 displayed, press and hold the DOWN key and then press the UP key. The display will blank momentarily, then show the line frequency it measured, then blank momentarily, and then display tSt4. The frequency measured, and displayed may not be exactly 50 or 60, but the software will assume it is 50 or 60 during normal operation.*

---

### 5.5.5 TEST 5 KEYPAD/DISPLAY TEST

This test allows the operator to verify that the keys work and that all display elements can be lighted. No special test equipment is required.

With tSt5 displayed, press and hold the DOWN key, then press the SCROLL key and then release both keys. The display will go blank. The following code will be displayed while the corresponding key is pressed:

<u>Key</u>	<u>Display</u>
SCROLL	SCrL
UP	uAro
DOWN	dAro
RESET (upper)	Autu
RESET (lower)	AutL
AUTO/MAN (Pen 1)	Autu
AUTO/MAN (Pen 2)	AutL
UP and DOWN	(All LED's and segments lit)
SCROLL and UP	(exit)

To exit, press the SCROLL and UP keys simultaneously, tSt5 will be displayed.

---

### 5.5.6 TEST 6 RELAY/ SOLID STATE RELAY DRIVER OUTPUT TEST

Allows the operator to verify that the Relay and /or the Solid State Relay Driver output(s) are working. A volt/ohm meter will be required to test the output.

With tSt6 displayed, press and hold the DOWN key, then press the SCROLL key. oFF will be displayed. For SPST Relay outputs, connect the meter across the relay output in the ohm scale. The meter should read continuity with the relay On and infinity when the relay is Off. For SSR Driver outputs, connect the meter across the output in the Volt DC scale. The meter should read 5 VDC when the SSR driver is On and 0 VDC when the driver is Off. Press and release the DOWN key to advance through the following sequence:

<u>DISPLAY</u>	<u>RELAY ON</u>
rLYA	SPST A
rLYb	B
rLYC	C
rLYd	D
oFF	None

To exit, press the SCROLL key and tSt6 will be displayed. **The existence of Relay and Solid State Relay Driver output(s) is dependent upon the hardware configuration.**

---

### 5.5.7 TEST 7 CURRENT OUTPUT TEST

This test allows the operator to verify that the current output(s) are functioning properly or will allow the selection of an output value for testing of associated equipment. A milliamp meter is required for testing.

With tSt7 displayed press and hold the DOWN key, then press the SCROLL key. The display will indicate **CurA**, for the first current output. By pressing the DOWN key, the instrument will advance through the selection sequence of **Curb** and then back to **CurA**. Choose the desired output to be tested and connect the milliamp meter across the output terminals being tested. Be sure to observe the proper polarity when connecting the meter. Terminal 1 is positive and

terminal 2 is negative. Press the SCROLL key and the display will indicate 4 milliamps. Use the UP and/or DOWN key to increase or decrease the current output in 1 mADC steps from 0 to 20 mADC.

The current output reading should be  $\pm 0.1$  mADC at any output value. A  $\pm 5\%$  of span adjustment for the current output(s) is provided by using the potentiometer adjacent to the current output on the Current Output board. See Appendix A-4 (page 65). To exit the test, press the SCROLL key and **tSt7** will be displayed. **The existence of a mADC current output is dependent upon the hardware configuration.**

---

### 5.5.8 TEST 8 PEN/CHART MOTOR TEST

This test allows the operator to verify that pen and chart motors are functioning properly. No special test equipment is required.

With **tSt8** displayed press and hold the DOWN key, then press the SCROLL key. The display will show **ALL** while the test is in progress. This test functions automatically. The chart speed will be at maximum, 72 seconds per revolution. Starting at the current pen position, pen 1 will move (sweep) upscale for about 5 seconds, then downscale for about 5 seconds. Pen 2 (if provided) will sweep in the opposite direction. The pens will continue to cycle until the test is exited. To exit, press the SCROLL key. The display will show **tSt8**.

---

### 5.5.9 TEST 9 AUXILIARY INPUT TEST

This test allows the operator to verify that the auxiliary input(s), if specified, pen position feedback input(s) are functioning properly.

Auxiliary inputs are the remote setpoint and position proportioning options. With **tSt9** displayed, press and hold the DOWN key, then press the SCROLL key. The display will show **Ai1**, Auxiliary Input 1. By pressing the DOWN key, the instrument will sequence through the selections for testing: **Ai2** then back to **Ai1**. With the desired input selected, press the SCROLL key. The corresponding value will be displayed. To terminate a particular test, press the SCROLL key. The display will show **tSt9**.

---

### 5.5.10 TEST A COMMUNICATIONS HARDWARE TEST (COMMUNICATIONS OPTIONAL)

This test allows the operator to verify that the communications hardware is functioning properly.

With **tStA** displayed, press and hold the DOWN key then press the SCROLL key. The display will indicate **SEnd**. Press the DOWN key to toggle the display between **SEnd** and **rEC**. With the desired function selected, press the SCROLL key. In the **SEnd** (send or transmit) mode, the instrument will repeat the following sequence. First the transmitter will output a logic 1 on the line for one second. Next the transmitter will change the logic level to 0 for one second. Then the transmitter will disable for one second. In the **rEC** (receive) mode, the transmitter is continuously disabled. In either mode, the instrument will monitor the line and display **rEC1** when a logic 1 is on the line or **rEC0** when a logic 0 is on the line. In the **SEnd** mode, the instrument will display **rEC** when the transmitter is disabled. To perform an internal test and verify the basic operation of the hardware, place the instrument in the Send mode and verify that the display cycles through **rEC1**, **rEC0**, and **rEC**. To verify that the transmitter functions properly, two LED's, each with a current limiting resistor, can be connected with opposite polarity observed to the TB 2 terminals 1 and 2. The following three states should be observed: one LED On, then the other LED On, then both Off. Alternately, a load resistor can be placed on the terminals, and observe that the voltage generated across the load resistor is as follows:  $>+3$  VDC, then  $>-3$  VDC, and then 0 VDC.

Another method, to test the communications hardware, would be to connect one or more instruments in the Receive mode to an instrument in the Send mode. All of the instruments in the Receive mode should have their displays alternating in sync with the instrument in the

Send mode. When the sending instrument displays **rEC**, the receiving instruments should display **rEC1**. To terminate the test, press the **SCROLL** key for one second. Upon exit, **tStA** will be displayed. **The existence of the communications hardware is dependent on the hardware configuration.**

---

## Trouble-shooting and Diagnostics 5.6

The Trouble-shooting Guidelines Section consists of two columns. The first column is a list of some possible instrument conditions. The second column is a list of steps that should improve the condition. The steps should be performed in order until the condition improves or all the steps have been completed. If the instrument condition has not improved, contact the nearest representative or the factory for assistance.

Trouble-shooting should be performed by qualified personnel using the proper equipment and following all safety precautions. Whenever possible the trouble-shooting should be accomplished with the electrical power disconnected. The instrument contains static sensitive components so care should be taken to observe anti-static procedures.

### **CONDITION**

**Display(s) is/are blank**

### **CORRECTION STEPS**

1. Verify that the correct instrument power, as indicated on the wiring label on the platen, is supplied to TB 1 terminals 1 & 2. Check the position of the power select switch, on 230 VAC models, correctly indicates the power that is connected to the instrument. If the switch does not indicate the correct voltage, reposition as necessary. If the voltage is not correct, check the power source.
2. Turn off the instrument power. Wait about 5 seconds then turn the power on again.
3. Turn off the instrument power, open the cover, loosen the platen hold down screw, and swing the platen out of the way. Inspect the instrument for poor connections.
  - a. The white ribbon cables that connect the Processor board (Appendix A-1, page 62) to the platen must be properly aligned and seated in the sockets.
  - b. The display board(s) white ribbon cable(s) pins should be properly aligned and seated in the sockets on the platen board.
  - c. Inspect the EPROM (U7), RAM (U8) and microprocessor chips (U5) to see that the legs are properly seated in their sockets on the Processor Board (page 62).
  - d. Close the platen and tighten the hold down screw. Close the cover and turn on the power to see if the display(s) will now light.
4. Turn off the instrument power. Press and hold the **UP** and **DOWN** keys. Turn on the power. Hold the keys pressed for about 10 seconds. If the display(s) light the model number, Program and Tune mode parameters will need to be re-entered (pages 28 thru 35 or Software Ref. Sheet, page 72, if already filled out).

---

**Model Number Displayed during power up is incorrect**

1. Turn off the instrument power, wait 5 seconds then re-apply the power. Verify that the number displayed during the power up sequence is the same as indicated on the label affixed to the platen. If the number displayed is incorrect, perform the following steps:
  - a. Turn off the power to the instrument. Press and hold the UP and DOWN keys. Turn on the power and keep the keys pressed until the model number displayed resets to **8XX0-0000-0X11** where the digits X are determined by the firmware installed. Release the keys and turn off the power.
  - b. To enter the correct model number, press and hold the SCROLL and DOWN keys and turn on the instrument power. **8XX0** should be displayed. Wait about 5 seconds and release the keys. The display should stay **8XX0**. Use the UP/DOWN keys as necessary to change the displayed number to match the first 4 digits of the model number as indicated on the label on the platen. After adjusting the first 4 digits to the proper values, press the SCROLL key and the display will change to **0000**. Use the UP/DOWN keys to set the next 4 digits of the model number to the correct values. Press the SCROLL key and the display will be **0X11**. Use the UP/DOWN keys as necessary to adjust the last 4 digits of the number. Press the SCROLL key and the power up sequence will complete. The Program and Tune mode parameters will need to be re-entered (pages 28 thru 35 or Software Ref. Sheet, page 72, if already filled out).

---

**Relay/SSR Driver Malfunction**

1. Verify that the Program and Tune mode parameters are correctly set (pages 28 thru 35 or Software Ref. Sheet, page 72, if already filled out).
2. Turn off the power to the instrument. Wait about 5 seconds and turn the power on again. Confirm that the model number displayed during the power up sequence indicates that the output(s) is/are present in the instrument. See Appendix C (page 68) for the model number explanation/decoding. This number should match the number on the label affixed to the platen.
3. Turn off the power to the instrument. Open the cover. Loosen the platen hold down screw and swing the platen open. Inspect the instrument Relay/SSR Driver board (See Figure 2-4, page 14) for the presence of the output device(s). A relay output will appear to be a cube. The SSR Driver will appear as a resistor and a jumper wire. The output will not work if the hardware is not present. Inspect that the output terminal connections are present and firmly attached.
4. Check the output(s) operation by performing Test 6 as described in the Test section (page 53). If the output(s) function in the Test mode re-examine the Program and Tune mode parameters settings (pages 28 thru 35 or Software Ref. Sheet, page 72, if already filled out).

- If the output appears not to turn off remove the power to the instrument. Open the cover and loosen the platen hold down screw. Swing the platen open. Clip the resistor located on the Relay Board adjacent to the output(s) that seem to stay on (See Appendix A-2, page 63). A .01 microfarad, 1 KV capacitor should be connected from the terminal listed below, for the output where the resistor indicated was removed, to the AC ground.

Relay A	R1	TB 6	Terminal 1
Relay B	R2	TB 6	Terminal 3
Relay C	R3	TB 7	Terminal 1
Relay D	R4	TB 7	Terminal 3

Close the platen and tighten the hold down screw. Close the cover and turn the power on to the instrument. Check the operation of the output(s).

**mADC Output(s)  
Malfunction**

- Verify that the Program mode parameters are correctly set (page 72).
- Turn Off the power to the instrument. Wait about 5 seconds and turn the power on again. Confirm that the model number displayed during the power up sequence indicates that the output(s) is/are present in the instrument. See Appendix C ( page 68) for the model number explanation/decoding. This number should match the number on the label affixed to the platen.
- Turn off the power to the instrument. Open the cover. Loosen the platen hold down screw and swing the platen open. Inspect the instrument Current Output board (See Figure 2-6, page 15) for the presence of the output device(s). The output will not work if the hardware is not present. Inspect that the output terminal connections are present and firmly attached. Close the platen and tighten the hold down screw. Close the cover and turn on the power.
- Refer to the Test section and carry out the procedure for the Current Output(s) Test 7 (page 53). If the current output operates properly in the Test mode re-check the Program mode parameters (page 28 or Software Ref. Sheet, page 72, if already filled out).

**Pen(s) do not operate**

- Verify that the Program mode parameters are properly set (page 28 or Software Ref. Sheet, page 72, if already filled out)
- If the process value in the display exceeds the chart upper or the chart lower values selected in the Program mode, the pen will appear stuck at the chart upper or lower edge respectively. Re-configure values as needed by the application (May require a new chart).
- Perform Test 8 as described in the Test section of the manual (page 54). If the pen(s) operate in Test 8, perform the pen calibration, Cal 9, as described in the Calibration section of the manual (page 50). Return the instrument to the **OPER** and check the operation of the pen(s).
- Verify the instrument is not in Change Chart function.

---

## ERROR CODE DISPLAYED

---

**SnSr** - Sensor Break or Over Range

1. Inspect the sensor for proper operation and connection to the instrument. Acceptable sensor ranges for the instrument are listed in the Specifications section of Appendix D (page 69).
2. Verify that the Program mode input selection matches the sensor input connected (page 28 or Software Ref. Sheet, page 72, if already filled out).
3. Check that the input conditioning jumpers on the Processor board (Appendix A-1, page 62) are in the proper position for the sensor input. Check that the jumpers are in the proper position for the Terminal Board where the sensor is connected.
4. Perform the calibration procedure(s), as described in the Calibration section (page 46), for the sensor input type.

---

**Hi** - Input more than 10% Over Span

1. Perform the steps listed for the **SnSr** Error Condition. (above)

---

**Lo** - Input more than 10% Under Span

1. Perform the steps listed for the **SnSr** Error Condition. (above)

---

**o** - display overranged (the "broken 6" appears on the left segment of the display)

1. If this error code is displayed as a Program or Alarm Set mode parameter perform the **CAL 1** procedure as described in the Calibration section of the manual (page 46).
2. If this error code appears as part of the model number during the power up sequence, follow the steps listed for the "**Model Number is not correct**" condition (page 56)
3. If this error appears, check the Program mode parameter **dPos**, if not 0, change to 0 and see if the error clears.

---

**Er 1** - Microprocessor RAM Failure

1. Turn off the power to the instrument. Wait 5 seconds, and turn the power on.
2. Turn off the power to the instrument. Open the cover, and loosen the platen hold down screw. Swing open the platen and inspect that the microprocessor chip is properly seated in the socket located on the Processor board (Appendix A-1, page 62). Close the platen and tighten the screw. Close the cover and turn on the power.

---

**Er 2** - External RAM Failure

1. Turn off the power to the instrument. Wait 5 seconds, and turn the power on.

---

**Er 3** - EPROM Checksum Failure

1. Perform the steps listed for **Er 1** except that the EPROM (U7) on the Processor board should be inspected.

<b>Er 4 - RTD Mismatch Error</b>	<ol style="list-style-type: none"> <li>1. Check the connections to the instrument for the RTD Input Calibration (CAL5) as described in the Calibration section (page 49). Repeat the RTD Input Calibration.</li> </ol>
<b>Er 5 - No Zero Crossings Detected</b>	<ol style="list-style-type: none"> <li>1. Turn off the power to the instrument. Wait 5 seconds, and turn the power on.</li> <li>2. Connect the instrument to another AC power source.</li> </ol>
<b>Er 6 - AC line below 43 HZ</b>	<ol style="list-style-type: none"> <li>1. Turn off the power to the instrument. Wait 5 seconds, and turn the power on.</li> <li>2. Connect the instrument to another AC power source.</li> </ol>
<b>Er 7 - AC line over 64 HZ</b>	<ol style="list-style-type: none"> <li>1. Turn off the power to the instrument. Wait 5 seconds, and turn the power on.</li> <li>2. Connect the instrument to another AC power source.</li> </ol>
<b>Er 8 - Cal 2 Volt Input Error</b>	<ol style="list-style-type: none"> <li>1. Check that 50 mVDC is properly connected to the instrument and is within the tolerance limits as indicated in the CAL2 procedure of the Calibration section (page 47).</li> <li>2. Turn off the power to the instrument and open the cover. Loosen the platen hold down screw and swing the platen open. Inspect the Processor board (Appendix A-1, page 62) to insure that the input conditioning jumper JU4 is in the non-volt position. The jumper must be in the non-volt position to perform the CAL 2 procedure properly. Close the platen and tighten the hold down screw. Close the cover and turn on the power to the instrument.</li> <li>3. Perform the CAL2 procedure as described in the Calibration section (page 47).</li> </ol>
<b>Er 9 - ADC Reference Number Error</b>	<ol style="list-style-type: none"> <li>1. Perform the CAL2 procedure as described in the Calibration section (page 47).</li> </ol>
<b>Er10 - ADC Reference Voltage Error</b>	<ol style="list-style-type: none"> <li>1. Perform the CAL2 procedure as described in the Calibration section (page 47).</li> </ol>
<b>Er11 - Cold Junction Compensation Error</b>	<ol style="list-style-type: none"> <li>1. Perform the CAL3 procedure as described in the Calibration section (page 48).</li> </ol>
<b>Er12 - CAL2 Voltage Error</b>	<ol style="list-style-type: none"> <li>1. Check that 50 mVDC is properly connected to the instrument and is within the tolerance limits as indicated in the CAL2 procedure of the Calibration section (page 47).</li> <li>2. Turn off the power to the instrument and open the cover. Loosen the platen hold down screw and swing the platen open. Inspect the Processor board (Appendix A-1, page 62) to insure that the input conditioning jumper JU4 is in the non-volt position.</li> <li>3. Perform the CAL2 procedure as described in the Calibration section (page 47).</li> </ol>

<b>Er13</b> - RTD CAL5 Input Error	<ol style="list-style-type: none"> <li>1. Check that resistance device is of the correct value and properly connected to the instrument and is within the tolerance limits as indicated in the CAL5 procedure of the Calibration section (page 49).</li> <li>2. Turn off the power to the instrument and open the cover. Loosen the platen hold down screw and swing the platen open. Inspect the Processor board (Appendix A-1, page 62) to insure that the input conditioning jumpers are in the correct position for the RTD input for the Terminal Board being calibrated. For TB 4, JU4 should be in the non-volt position and JU6 in the RTD position. For TB 5, JU5 should be in the non-volt position and JU7 in the RTD position.</li> <li>3. Perform the CAL5 procedure as described in the Calibration section (page 49).</li> </ol>
<b>Er14</b> - Cold Junction Compensation Error	<ol style="list-style-type: none"> <li>1. Perform the CAL3 procedure as described in the Calibration section (page 48).</li> </ol>
<b>Er15</b> - Ground Reference Tolerance Error	<ol style="list-style-type: none"> <li>1. Perform the CAL2 procedure as described in the Calibration section (page 47).</li> </ol>
<b>Er16</b> - Program/ASEt Mode parameters. Checksum Error	<ol style="list-style-type: none"> <li>1. Record all Program, Tune and Alarm Set mode Perform CAL 1 procedure as described in the Calibration section (page 47). Re-enter all parameters.</li> </ol>
<b>Er17</b> - Calibration Checksum Error	<ol style="list-style-type: none"> <li>1. Perform the calibration procedures that are needed for the input sensors that will be used (page 46).</li> </ol>
<b>Er36</b> - Incorrect Crystal For Digital Comm.	<ol style="list-style-type: none"> <li>1. Turn off the power to the instrument, wait 5 seconds, then turn the power on.</li> </ol>
<b>Er37</b> - Incorrect Micro. For Digital Comm.	<ol style="list-style-type: none"> <li>1. Turn off the power to the instrument wait 5 seconds, then turn the power on.</li> </ol>
<b>Er38</b> - Incorrect RAM for profiler	<ol style="list-style-type: none"> <li>1. Turn off the power to the instrument, wait 5 seconds, then turn the power on.</li> <li>2. Re-configure for non-profiler.</li> </ol>
<b>Momentary Er70</b> - Controller unable to respond within 250 milliseconds	<ol style="list-style-type: none"> <li>1. May occur when incrementing or decrementing a value. Error clears itself.</li> </ol>
<b>Momentary Er71</b> - Byte received before the response was transmitted	<ol style="list-style-type: none"> <li>1. Computer program must wait longer for a response from the instrument.</li> </ol>

---

**Momentary Er 72 -**  
Incorrect Block Check  
character was received

1. Data received not valid, possible corruption on the comm line. Possible noise problems. Check baud rates, instrument addresses, line connections, and termination.

---

**Momentary Er 73 -**  
Byte received with incorrect  
parity.

1. Check baud rate.
2. Possible noise problems. Check instrument addresses, line connections, and termination.

# Appendix A Board Layouts

**FIGURE A-1 - PROCESSOR BOARD**

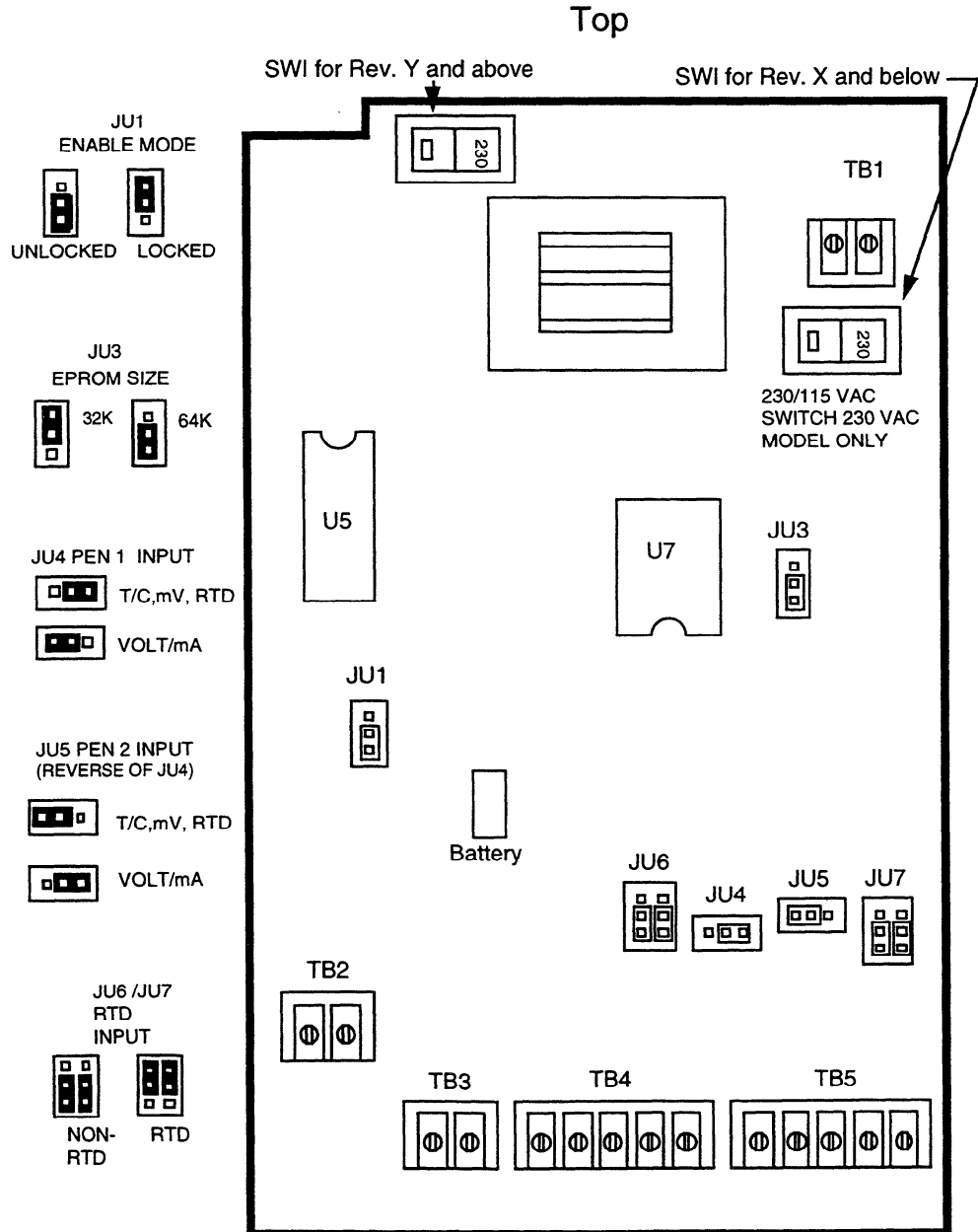

**FIGURE A-2 - SPST RELAY/SSR DRIVER OUTPUT BOARD**

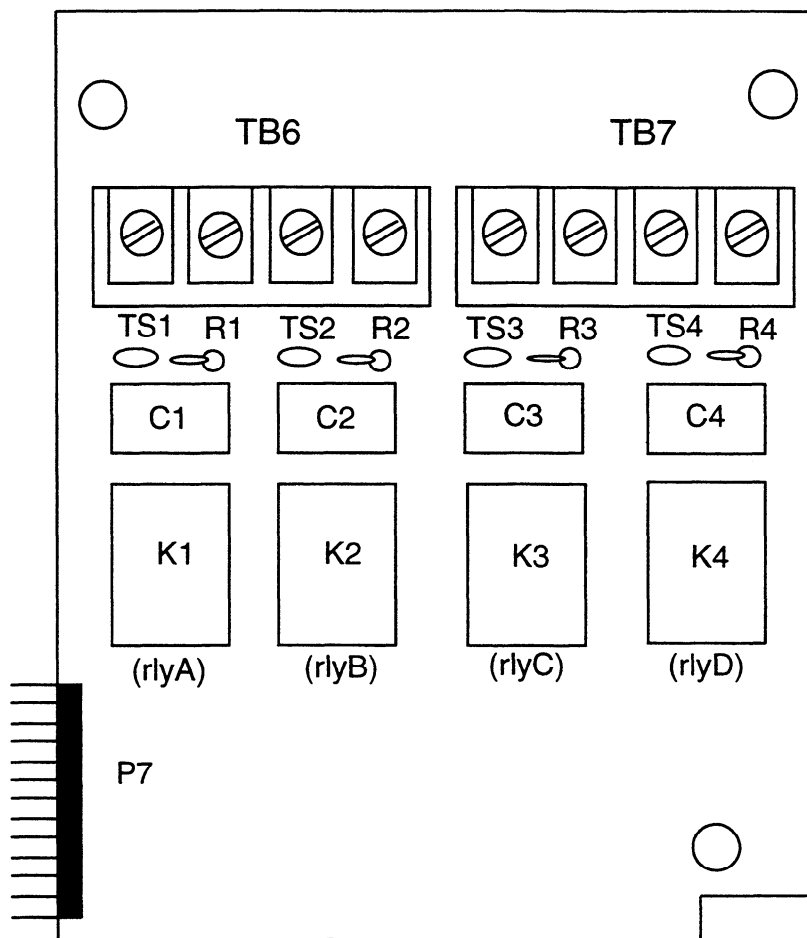

If the relay is connected to a high impedance AC device, the snubber network used to protect the relay contact may cause the output to appear to be activated when the relay is off. To cure the problem, cut the snubber resistor for the output that is being affected.

<u>Resistor</u>	<u>Relay</u>
R1	Relay A
R2	Relay B
R3	Relay C
R4	Relay D

**FIGURE A-3 - CURRENT OUTPUT BOARD**

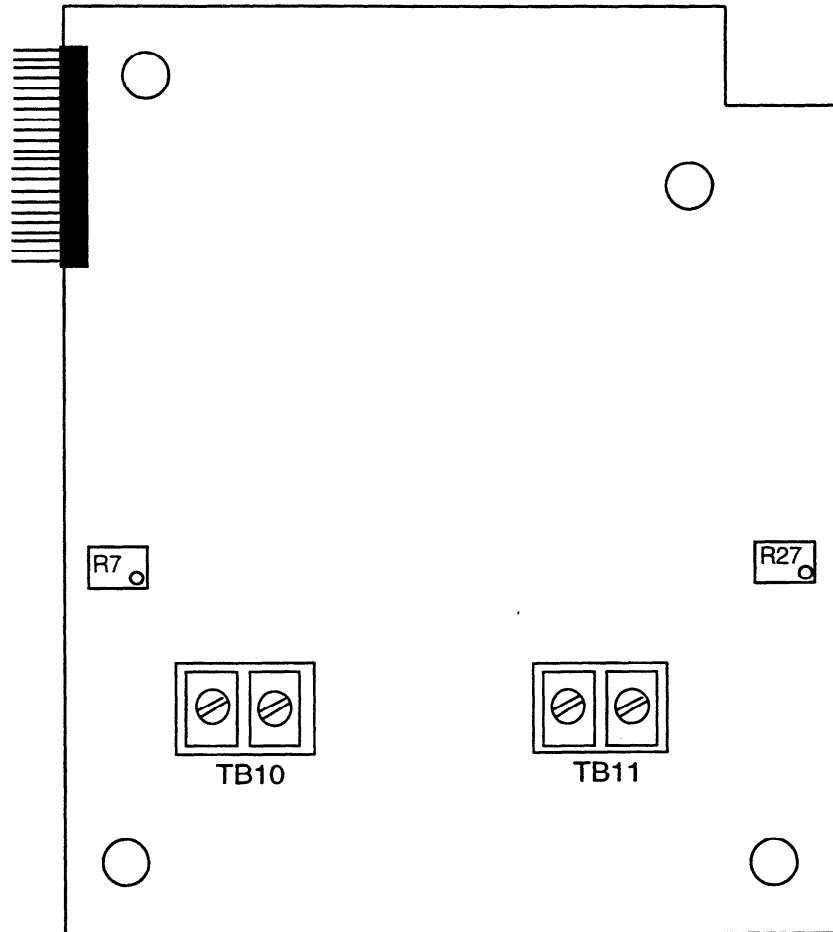

If this option board was ordered, you will find it located in the lower right hand corner of the instrument.

---

# Appendix B

## Glossary

### Automatic Reset (Integral)

This parameter is used so that the instrument will compensate for process variable deviations from setpoint that occur when the process load characteristics change. Instructions for determining the automatic reset settings are given in Table 3-2 (Page 34). Factory default is 0.0. Display code **ArSt**.

### Automatic Transfer

This feature, if configured, allows manual control of the process until setpoint is reached, at which point the controller automatically transfers from manual to automatic control. Factory default value is 0 = no auto transfer. Display code **AtFr**.

### Bumpless Transfer

This feature prevents step changes in proportional outputs when changing from automatic to manual control only.

### Cycle Time

This Tune mode parameter is used to select the on/off cycle time for time proportioning outputs (**Ct1** for Output 1 and/or **Ct2** for Output 2). When using the Position Proportioning option, **Ct1** must be selected for the stroke time of the motor.

### Display Filter Factor

This parameter is adjustable from 1 to 20 which represents the number of scans per second of the process variable that are averaged together before updating the displayed and recorded value. The factory default value is 1 = no filtering. Display code **dFF**.

### Engineering Units Upper and Engineering Units Lower

These Program mode parameters are used with volt, millivolt, and milliamp inputs. The Engineering Units Upper **EuU** should be selected as the value to be displayed when the input is at maximum. The Engineering Units Lower **EuL** should be selected as the value to be displayed when the input is at minimum.

### First Output Position

This parameter is adjustable from -1000 to 1000 units and represents a shift or offset of the on-off actuation points or proportional band for the first output relative to the normal position. For example, a negative value could be used to offset an expected overshoot. First Output Position also shifts the proportional band with respect to the process value range outside of which integral action is inhibited. Factory default is 0. Display code **FoP**.

### Hysteresis

This parameter is adjustable from 0 to 300 units representing the width of the band (half above and half below setpoint). Used with ON/OFF or Alarm outputs to reduce cycling. For instance, with a value of 4 and a setpoint of 70 the output will turn ON when the process variable drops to 68 and stay ON until 72 is reached, then turn OFF the output. Factory default = 3. Display code **HyAo** for Alarm outputs. Display code **HyCo** for ON/OFF Control outputs.

### Input Correction

This parameter is adjustable from -300 to 300 units and is used as a method to compensate for a linear sensor error. Factory default is 0 = no correction. Display code **iCi1**, **iCi2**.

### Manual Reset

This parameter is adjustable from -1500 to 1500 units representing a manual shift of proportional band(s) relative to the normal position which is an even straddle of the setpoint. Manual reset is intended to be used when automatic reset is not used to allow compensation for deviations from setpoint which remain after the process has stabilized. Factory default is 0. Increasing the value increases the process variable, i.e. if the process variable stabilizes too low, increase the manual set. Integral action, and conversely reset-windup inhibit apply over the same process value range regardless of the manual reset value. Display code **rSEt**.

**Pen Action on Power Up**

This parameter specifies whether the pen, on a power-up will drive to the "Home Position" (center of chart), then return to its correct position. This is done as a cal check. Settings are 0=go to "home" and 1=remain in last position prior to power down. Default is 0.

**Platen**

The flat surface in the instrument upon which the chart rotates.

**Position Proportioning Sensitivity**

A percentage of the first output proportional band width (Pb1).

**Process Filter Factor**

This parameter is adjustable from 1 to 20 which represents the number of scans per second of the process variable that are averaged together before updating the process value used for control purposes. The factory default value is 1 = no filtering. Display code **PF**.

**Process Retransmission Output**

Allows re-transmission of the process variable. Factory default is 0 = not selected. Display code **Pout**. If selected, must be assigned to a current output and scaled using Process Output upper and lower values.

**Process Output Upper and Lower Values**

**(Used in conjunction with process retransmission output)**

These parameters specify the process value range over which the assigned current output will vary in a linear manner from 100% to 0%. If the process value is greater than **Pou** the output will be 100%. If the process value is less than **PoL** the output will be 0%. Factory default values are 2000 for the upper value and 0 for the lower value. Display codes **Pou** (upper) and **PoL** (lower).

**Process Rounding**

This parameter is adjustable from 0 to 100 units and is used to round the process value to the nearest value specified. This is for display only and does not affect the recorded value or control action. Intended for use where the engineering units span is large, to reduce display fluctuation. Factory default is 0 = no rounding. Display code **Prnd**. (e.g. Prnd = 3, Process Value = -6, -3, 0, 3, 6, 9....)

**Proportional Band (PB)**

This parameter is adjustable from 1 to 3000 units (not Percent of span) and represents the process value range where the proportional output is at a percentage of the full output. Instructions for determining Pb are given in Section 4.3 (page 42) . Factory default is 100 units. Display code **Pb1** and **Pb2**.

**Rate (Derivative)**

This parameter is adjustable from 0.0 to 10.0 minutes and specifies how the control action responds to the rate of change in the process variable. For example, if the process variable is rising rapidly to setpoint, power is turned off sooner than it would be if the rise were slow. In effect, derivative action anticipates lags within the system and shifts the proportioning band by an amount determined by the rate of change of the input sensor.

Magnitude of the shift is determined by a derivative time constant. If the time constant is, say, .1 minute (6 seconds), for every unit per second rate of change of the process variable at the sensor, the proportioning band is moved 7 units in the direction that helps control. Likewise, if the time constant is 1 minute (60 seconds), for every unit per second rate of change of the process variable at the sensor, the proportioning band is moved 60 units in the direction that helps control. Factory default is 0.0 Display code **rAtE**.

**Second Output Position (SoP)**

This parameter is adjustable from -1000 to 1000 units and represents a shift or offset of the on-off actuation points or proportional band for the second output relative to the normal position. A positive value creates a gap where no control outputs are on, a negative value creates an overlap of control outputs (if the first output position is at the normal position). Second Output Position also shifts the proportional band with respect to the process value range outside of which integral action is highlighted (reset-windup inhibit). Factory default is 0. Display code **SoP**.

# Appendix C Order Matrix

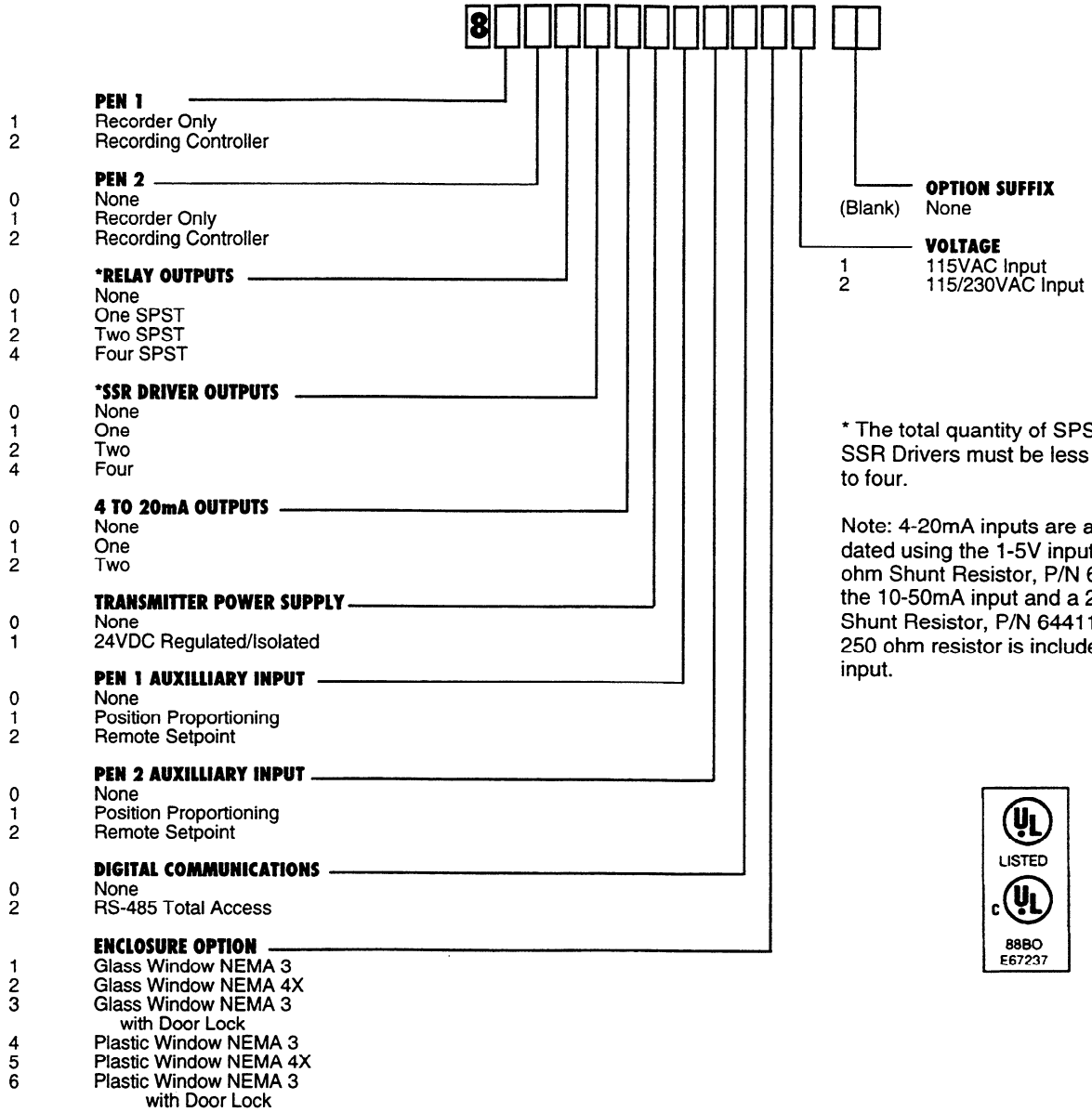

\* The total quantity of SPST Relays and SSR Drivers must be less than or equal to four.

Note: 4-20mA inputs are accommodated using the 1-5V input and a 250 ohm Shunt Resistor, P/N 64411701 or the 10-50mA input and a 2.5 ohm Shunt Resistor, P/N 64411702. The 250 ohm resistor is included for each input.

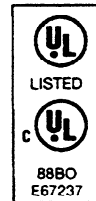

# Appendix D Product Specifications

## INPUTS

Input Types/Range	Type	Range
Thermocouple	J	0°C to 760°C 0°F to 1400°F
	K	0°C to 1360°C 0°F to 2500°F
	T	-200°C to 400°C -330°F to 750°F
	R	200°C to 1650°C 400°F to 3000°F
	S	200°C to 1650°C 400°F to 3000°F
	E	0°C to 750°C 0°F to 1400°F
	B	200°C to 1800°C 400°F to 3300°F
	N	0°C to 1300°C 0°F to 2370°F
	C	200°C to 2300°C 390°F to 4170°F
RTD	100 ohm Platinum -140°C to 400°C -220°F to 750°F	
Current DC	.00385 ohms/ohm/°C	
	0 to 20mA, 4 to 20mA	
Voltage DC	External Shunt Resistor, 2.5 ohms or 250 ohms	
	0 to 25mV, 0 to 50mV, 10 to 50mV, 0 to 5 V, 1 to 5 V	
Impedance	> 100M ohm for TC and mV inputs	
	100K ohms for 5V inputs	
RTD Excitation Current	2.5 ohms or 250 ohms for mA inputs	
Input Scan Rate	330 microamps, typical	
Input Correction	1 scan per second	
Remote Setpoint	Offset Adjustment, -999 to 999 units	
Sensor Fault Detection	0 to 5V, 1 to 5V	
Sensor Fault Detection	Sensor break on all TCs, RTDs, 1volt, 1 to 5 volt, 4-20mA, and millivolt inputs No sensor break can be detected for zero based Volt and Milliamp ranges Display goes to "SnSr" and pen goes upscale if a sensor break is detected Display goes to "Hi" 5% above span Display goes "Lo" 5% below span	
Transmitter Power Supplies	One isolated 50mA @ 24VDC supply available	

## INPUT PERFORMANCE

### Performance Under Reference Condition:

Measurement Error	Type J, K, T, E, N, C, T/C and RTD: $\pm 0.25\%$ of span $\pm 1$ degree Type R, S, B, C, T/Cs: $\pm 0.25\%$ of span @ 25°C mVDC and VDC: $\pm 0.25\%$ of scaled span plus 1 least significant digit
Cold Junction Compensation Error	$\pm 0.2^\circ\text{C}$ @ 25°C
Cold Junction Compensation Rejection	0.04°/°C deviation from 25°C
Linearization Error	TCs: $\pm 0.25^\circ\text{C}$ typical, $\pm 0.5^\circ\text{C}$ worst case with expectations RTDs: $\pm 0.1^\circ\text{C}$ typical, $\pm 0.3^\circ\text{C}$ worst case
Ambient Temperature Error	$\pm 0.01\%$ of span per°C deviation from 25°C
Common Mode Rejection	90 db minimum; 24VAC maximum for RTD input; 115 VAC maximum all others for other inputs
Normal Mode Rejection	85 dB minimum @60Hz or greater
Isolation	RTD Inputs 24VAC. All other inputs 115VAC Inputs share a common signal ground

### Reference Conditions

Ambient Temperature	25°C
Relative Humidity	60 - 70%
Supply Voltage	115 VAC, 60 Hz
Source Resistance	< 10 ohms for TC input
Lead Resistance	< 0.1 ohm/lead balanced (Pt100)

---

## **RECORDING**

Pen Type	Disposable fiber tip
Pen Color	Pen 1 - Red Pen 2 - Green
Chart Size	12 inch
Chart Drive	Stepper motor
Chart Rotation	User configurable: 0.1 to 999 hours, in 0.1 hour increments
Chart Span	Bottom and top of span, -9999 to 9999 units
Filtering	1 to 20 scans averaging (affects display and recording)

---

## **RECORDING PERFORMANCE**

Chart Recording Accuracy	0.5% of chart span reference accuracy
Resolution	0.15% of chart span
Dead Band	0.3% of chart span
Response Time	20 seconds for full scale travel
Chart Rotation Accuracy	±0.5% of rotation time, assuming all backlash removed

---

## **OPERATOR INTERFACE**

Display	Four digit, 0.56" high, red, seven segment, LED display
Resolution	TCR and RTD: 0.1 and 1 degree mV, V and mA: 0.001, 0.01, 0.1, and 1 unit
Status Indicators	Recorders: ALRM1 and ALRM2; red LEDs Controllers: MAN, OUT1, OUT2, ALRM; yellow, red, yellow, red LEDs
Keypad	Three keys for programming and unit operation One or Two Auto/Man keys on controllers
Display Modes	Recorders: Process value(s) Controllers: Process value(s) or deviation(s), with or without setpoint sequentially

---

## **ALARMS**

Number	Up to two process alarms for each of two inputs
Type	Recorder: Process high or low Controllers: Process, deviation, or band
Hysteresis	Fully adjustable, 0 to 300 units, straddles alarm point
Security	Alarm setpoint changes can be prohibited
Sensor Fault Action	Alarms work normally in "Hi" and "Lo" conditions Alarm relays are deenergized in a "SnSr" sensor break condition

---

## **ON/OFF OUTPUTS**

On/Off Outputs	Assignable to alarm or control outputs
Relays	SPDT, contacts rated 5 amps resistive at 115 VAC, 2.5 amps resistive at 230 VAC, 1/8 HP at 230 VAC (single phase), 250 VA at 115/230VAC
Solid State Relay Driver	Open collector output, can provide 40mA at 3 VDC or 20mA at 4 VDC Short circuit current is limited to 100mA

---

## **CURRENT OUTPUTS**

Drivers	Assignable to process value or setpoint retransmission or control outputs
Output Span	0 to 20mA or 4-20mA, nominal
Resolution	0.02 % of 20mA; 12 bits over a 0 to 25.6mA span
Accuracy	±0.1% to 20mA span reference accuracy
Compliance	650 ohm load

---

## **POWER REQUIREMENTS**

Line Voltage 115/230 VAC,  $\pm 10\%$ , 50/60 Hz  
Power Consumption: 25 VA Maximum

---

## **CONSTRUCTION**

Enclosure Gasketed cover, case, and windows. Structural foam case and covered with plastic or glass window area. Door lock available  
NEMA Rating NEMA 3 standard, NEMA 4X optional  
Conduit Openings Four openings standard, 2 additional as required  
Mounting Panel or wall or optional pipe mounting  
Overall Dimensions 14.12" wide X 16.77" high X 7.75" deep  
(358.65mm wide X 425.96mm high X 196.85mm deep)  
Panel Cutout 12.7" wide X 12.7" high  
(322.58mm X 322.58mm)  
Panel Depth 5.25" (133.35mm)  
Panel Protrusion 2.5" (63.5mm)  
Weight 20lbs maximum

---

## **ENVIRONMENTAL AND OPERATING CONDITIONS**

Operating Temperature 0°C to 55°C (32°F to 131°F)  
Storage Temperature -40°C to 65°C (-4°F to 149°F)  
Humidity 10 to 90% RH, non-condensing  
Vibration 0.5 to 100 Hz @ 0.2g  
Mounting Position Up to 30° forward or backward tilt from vertical  
Up to 10° side tilt from vertical

---

## **DIGITAL COMMUNICATIONS**

Communications Port RS-485 serial communications, Half-duplex  
Protocol Parlow ASCII - ANSI x 3.28, subcategory 2.5 & A4  
Bit Rate 9600, 4800, 2400, 1200, 600, 300 bits per second  
Configuration Monitor: read only, Normal: read and write  
Address User configurable - 0 to 99 for each pen

---

## **GENERAL REFERENCE DATA**

Data Backup Battery backed SRAM for all data  
Battery Backup 5 years minimum life, 10 years typically  
Warranty Two years

---

## **APPROVALS AND COMPLIANCE**

Safety UL Approved for USA - UL 1092, UL 916, and QUXY - File E67237: Pending  
UL Certified for Canada - CSA Spec 142 - File E67237: Pending

# Appendix E

## Software Reference/Record Sheet

### Recorders:

ENABLE MODE	
EtSt	
ECAL	
EPro	
EASt	
ESPC	

ALARM SET		
	Pen 1	Pen 2
PAL1		
PAL2		

	PROGRAM MODE		unit
	Pen 1	Pen 2	
inPS			rLyA
iCor			rLyb
AL1			rLyC
AL2			rLyd
disP			CurA
dPoS			Curb
Euu			CoAr
EuL			Cobr
HyAo			Crt
SPuL			PAPu
SPLL			Coo
Prnd			CCon
dFF			CbS
PFF			CAd1
Pout			CAd2
Pou			
PoL			
Cru			
CrL			
PAEC			

## Recording Controllers:

PROGRAM MODE			
	Pen 1	Pen 2	unit
inPS			rLyA
iCor			rLyb
out1			rLyC
o1uL			rLyd
o1LL			CurA
out2			Curb
o2uL			CoAr
o2LL			Cobr
AL1			Crt
AL2			PAPu
diSP			Coo
dPoS			CCon
Euu			CbS
EuL			CAd1
HyCo			CAd2
HyAo			
rSP			
rSPu			
rSPL			
SPuL			
SPLL			
AtFr			
Prnd			
dFF			
PFF			
Pout			
Pou			
PoL			
Cru			
CrL			
P1EC			
P2EC			
PAEC			

TUNE MODE		
	Pen 1	Pen 2
SoP		
PAL1		
dAL1		
bAL1		
PAL2		
dAL2		
bAL2		
Pb1		
Pb2		
rSEt		
ArSt		
rAtE		
Ct1		
Ct2		
SEnS		
FoP		

ENABLE MODE	
EtSt	
ECAL	
EPro	
Etun	
ESby	
ESPS	
ESPC	

---

## ***Warranty and Return Statement***

These products are sold by The Partlow Corporation (Partlow) under the warranties set forth in the following paragraphs. Such warranties are extended only with respect to a purchase of these products, as new merchandise, directly from Partlow or from a Partlow distributor, representative or reseller, and are extended only to the first buyer thereof who purchases them other than for the purpose of resale.

### ***Warranty***

These products are warranted to be free from functional defects in materials and workmanship at the time the products leave the Partlow factory and to conform at that time to the specifications set forth in the relevant Partlow instruction manual or manuals, sheet or sheets, for such products for a period of two years.

**THERE ARE NO EXPRESSED OR IMPLIED WARRANTIES WHICH EXTEND BEYOND THE WARRANTIES HEREIN AND ABOVE SET FORTH. PARTLOW MAKES NO WARRANTY OF MERCHANTABILITY OR FITNESS FOR A PARTICULAR PURPOSE WITH RESPECT TO THE PRODUCTS.**

### ***Limitations***

Partlow shall not be liable for any incidental damages, consequential damages, special damages, or any other damages, costs or expenses excepting only the cost or expense of repair or replacement as described above.

Products must be installed and maintained in accordance with Partlow instructions. Users are responsible for the suitability of the products to their application. There is no warranty against damage resulting from corrosion, misapplication, improper specifications or other operating condition beyond our control. Claims against carriers for damage in transit must be filed by the buyer.

This warranty is void if the purchaser uses non-factory approved replacement parts and supplies or if the purchaser attempts to repair the product themselves or through a third party without Partlow authorization.

### ***Returns***

Partlow's sole and exclusive obligation and buyer's sole and exclusive remedy under the above warranty is limited to repairing or replacing (at Partlow's option), free of charge, the products which are reported in writing to Partlow at its main office indicated below.

Partlow is to be advised of return requests during normal business hours and such returns are to include a statement of the observed deficiency. The buyer shall pre-pay shipping charges for products returned and Partlow or its representative shall pay for the return of the products to the buyer.

Approved returns should be sent to:      PARTLOW CORPORATION  
2 CAMPION ROAD  
NEW HARTFORD, NY 13413 USA



**ISO 9002 Certified**

PARTLOW CORPORATION • 2 CAMPION ROAD • NEW HARTFORD, NY 13413 USA • 1-800-866-6659 • 315-797-2222 • FAX 315-797-0403

**PROGRAM MODE - PARTLOW 7000 & 8000 - SINGLE PEN MIXER KETTLE**

STEP	DESCRIPTION	DISPLAY CODE	YOUR SETTING	
			F	C
1	INPUT SELECT	inPS	21	20
2	INPUT CORRECTION	iCor	0	
3	OUTPUT 1	Out1	2	
6	OUTPUT 2	Out 2	0	
9	ALARM 1 - THE ALARM POINT IS SELECTED IN THE TUNE MODE	AL1	4	
10	ALARM 2	AL 2	3	
11	DISPLAY SELECT	diSP	2	
12	DECIMAL POSITION	dpos	0	
15	HYSTERESIS FOR CONTROL OUTPUTS	HyCo	1	
16	HYSTEESIS FOR ALARM OUTPUTS	HyAo	1	
20	SETPOINT UPPER LIMIT	SPul	230	150
21	SETPOINT LOWER LIMIT	SPLL	30	0
22	AUTOMATIC TRANSFER	AtFr	0	
23	PROCESS ROUNDING OF DISPLAY AND RECORDED VALUE	Prnd	0	
24	DISPLAY FILTER FACTOR	dFF	1	
25	PROCESS FILTER FACTOR	PFF	1	
26	PROCESS VALUE OUTPUT RETRANSMISSION (IF POUT = 0 THEN POU AND POL WILL NOT BE DISPLAYED)	Pout	0	
29	CHART RANGE UPPER VALUE	Cru	230	150
30	CHART RANGE LOWER VALUE	CrL	30	0

**PROGRAM MODE - PARTLOW 7000 & 8000 - SINGLE PEN MIXER KETTLE**

STEP	DESCRIPTION	DISPLAY CODE	YOUR SETTING	
			F	C
33	PEN ACTION ON ERROR CONDITION	PAEC	1	
34	RELAY A ASSIGNMENT	rLyA	5	
35	RELAY B ASSIGNMENT	rLyb	1	
36	RELAY C ASSIGNMENT	rLyC	2	
37	RELAY D ASSIGNMENT	rLyd	0	
50	CHART ROTATION TIME	Crt	24.0	
51	CHART OPERATION IN OFF MODE	Coo	0	

## PROGRAM MODE - PARTLOW 7000 & 8000 - SINGLE PEN MIXER KETTLE

STEP	DESCRIPTION	DISPLAY CODE	YOUR SETTING	
			F	C
3	DEVIATION ALARM 1	dAL1	-10	-4
6	DEVIATION ALARM 2	dAL2	10	4
16	FIRST OUTPUT POSITION	FoP	0	

## ENABLE MODE - PARTLOW 7000 & 8000

STEP	DESCRIPTION	DISPLAY CODE	YOUR SETTING
1	TEST MODE	EtSt	OFF
2	CALIBRATION MODE	ECAL	OFF
3	PROGRAM MODE	EPro	OFF
4	TUNE MODE	Etun	OFF
5	MANUAL (STBY) MODE	ESby	OFF
7	SETPOINT CHANGE	ESPC	ON