



Operators Manual

Installation, Operation & Service

Gas Floor Model Vertical Mixer Kettles

MODELS:
MKGL-40-T
MKGL-60-T
MKGL-80-T
MKGL-100-T



1333 East 179th St., Cleveland, Ohio, U.S.A. 44110

Enodis

Phone: (216) 481-4900 Fax: (216) 481-3782
Visit our web site at www.clevelandrange.com

FOR THE USER

IMPORTANT!

ENSURE KETTLE IS AT ROOM TEMPERATURE AND PRESSURE GAUGE IS SHOWING ZERO OR LESS PRESSURE PRIOR TO REMOVING ANY FITTINGS.

FOR YOUR SAFETY

DO NOT STORE OR USE GASOLINE OR ANY OTHER FLAMMABLE LIQUIDS AND VAPOURS IN THE VICINITY OF THIS OR ANY OTHER APPLIANCE.

WARNING: Improper installation, adjustment, alteration, service or maintenance can cause property damage, injury or death. Read the installation and operating instructions thoroughly before installing or servicing this equipment.

IMPORTANT

The following points are to insure the safe installation and operation of this equipment:

- Insure all gas and electrical supplies match rating plate and electrical stickers.
- Observe all clearance requirements.
- Disconnect the electrical power supply to the appliance before cleaning or servicing unit.
- All service must be performed by a qualified Cleveland Range Technician.
- Do not obstruct the flow of combustion and ventilation air.

The installation and connection must comply with current local codes, or in the absence of local codes, with CAN/CGA-B149.1 and .2 installation code or with the national fuel gas code, ANSI Z223.1-L988.

Post in a prominent location, instructions to be followed in the event the user smells gas. This information shall be obtained by consulting your local gas supplier.

The appliance and its individual shut off valve must be disconnected from the gas supply piping system during any pressure testing of that system at test pressures in excess of 1/2 psig. (3.45 kpa).

The appliance must be isolated from the gas supply piping system by closing its individual manual shut off valve during any pressure testing of the gas supply piping system at test pressures equal to or less than 1/2 psig. (3.45 kpa).

RETAIN THIS MANUAL FOR YOUR REFERENCE.

For your safety

DANGER

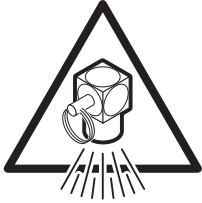

Keep clear of pressure relief discharge.



Keep hands away from moving parts and pinch points.

IMPORTANT



Inspect unit daily for proper operation.

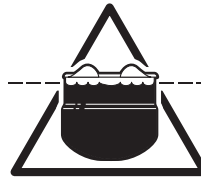

Do not fill kettle above recommended level marked on outside of kettle.

CAUTION



Surfaces may be extremely hot! Use protective equipment.



Wear protective equipment when discharging hot product.



Do not lean on or place objects on kettle lip.



Stand clear of product discharge path when discharging hot product.

SERVICING

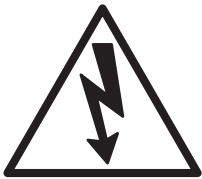

Shut off power at main fuse disconnect prior to servicing.



Ensure kettle is at room temperature and pressure gauge is showing zero or less prior to removing any fittings.

GAS APPLIANCES

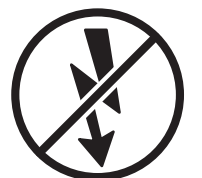

Do not attempt to operate this appliance during a power failure.



Keep appliance and area free and clear of combustibles.

INSTALLATION

INSPECTION

Before unpacking visually inspect the unit for evidence of damage during shipping.

If damage is noticed, do not unpack the unit, follow shipping damage instructions.

SHIPPING DAMAGE INSTRUCTIONS

If shipping damage to the unit is discovered or suspected, observe the following guidelines in preparing a shipping damage claim.

1. Write down a description of the damage or the reason for suspecting damage as soon as it is discovered. This will help in filling out the claim forms later.
2. As soon as damage is discovered or suspected, notify the carrier that delivered the shipment.
3. Arrange for the carrier's representative to examine the damage.
4. Fill out all carrier claims forms and have the examining carrier sign and date each form.

GENERAL

Installation of the kettle must be accomplished by qualified installation personnel working to all applicable local and national codes. Improper installation of product could cause injury or damage.

This equipment is built to comply with applicable standards for manufacturers. Included among those approval agencies are: UL, A.G.A., NSF, ASME/N.Bd., CSA, CGA, ETL, and others. Many local codes exist, and it is the responsibility of the owner/installer to comply with these codes.

Observe all clearance requirements to provide proper make-up air flow. Do not obstruct the flow of combustion and ventilation air. Check rating plate to ensure that kettle has been equipped to operate with the type of gas available at the installation.

VENTILATION

Gas fired kettles are only to be installed under a ventilation hood in a room which has provisions for adequate make up air. Further information can be obtained by referring to the U.S.A. National Fire Protection Associations NFPA96 regulations. These standards have also been adopted by the National Building Code in Canada.

CLEARANCE REQUIREMENTS

This unit must be installed in accordance with the clearances shown on the rating label which is adhered to the unit.

FOR YOUR SAFETY. Keep the appliance area free and clear of combustible materials.

GAS

ENSURE THE GAS SUPPLY MATCHES THE KETTLE'S REQUIREMENTS AS STATED ON THE RATING PLATE.

It is recommended that a sediment trap (drip leg) be installed in the gas supply line. If the gas pressure exceeds 14" water column, a pressure regulator must be installed, to provide a maximum of 14" water column gas pressure to the gas control valve.

Connect the gas line to the manual valve located at the rear of the control box.

Installation must be in accordance with local codes and/or the National Fuel Gas Code ANSI Z223.1 Latest Edition (USA) or the latest Installation Codes for Gas Burning Appliances and Equipment CAN/ CGA B149.1 and CAN/ CGA B149.2 (Canada). Use a gas pipe joint compound which is resistant to L.P. gas. Test all pipe joints for leaks with soap and water solution. Ensure that the gas pressure regulator is set for the manifold pressure indicated on the gas rating plate.

The appliance and its individual shut-off valve must be disconnected from the gas supply piping system during any pressure testing of that system at test pressures in excess of 1/2 psi (3.45 kPa). The appliance must be isolated from the gas supply piping system by closing its individual manual shut-off valve during any pressure testing of the gas supply piping system at test pressures equal to or less than 1/2 psi (3.45 kPa).

WATER

The sealed jacket of the gas-fired kettle is precharged with the correct amount of a water-based formula, and therefore, no water connection is required to the kettle jacket. The kettle can be equipped with optional hot and cold water taps, the taps require 1/2" copper tubing as supply lines.

CLEANING

After installation the kettle must be thoroughly cleaned and sanitized prior to cooking.

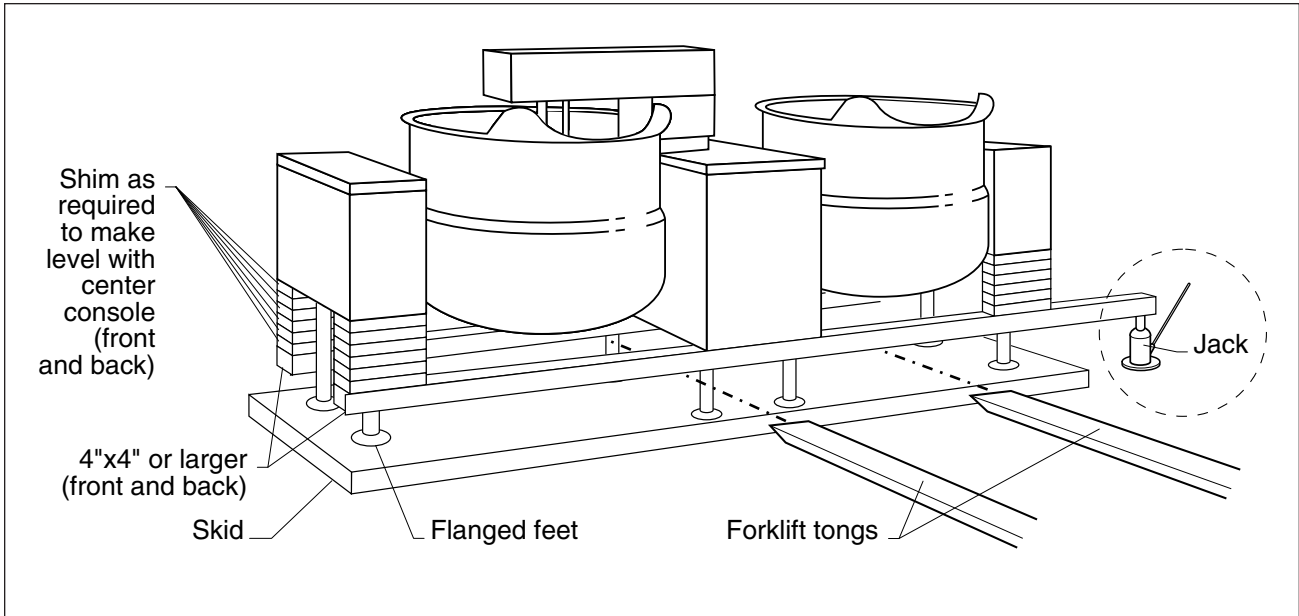

Recommended Installation Procedure

MOVING UNIT

1. While still on skid, move unit as close to final installation position as possible.
2. Prepare unit for lifting as shown in diagram.
3. Lift gently with a forklift or jacks and remove skid.
4. Lower gently to ground and remove forklift and blocking.
5. If unit has to be re-positioned, slide gently. Do not twist or push one side of unit excessively and cause binding on trunnions.

LEVELING

Note: Instructions reflect a more complicated twin mixer kettle - process for single mixer kettles is the same.

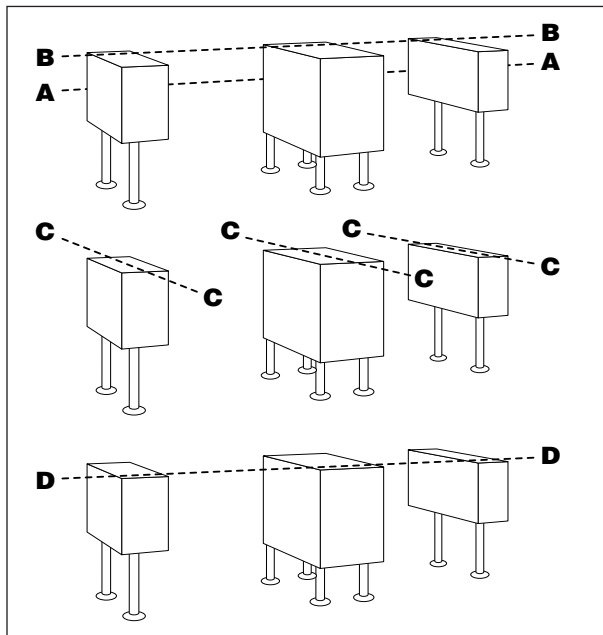

Recommended Leveling Procedure

1. With straight-edge, line the backs of the consoles up with each other (dotted line **A**).

2. Level and straight-edge backs of consoles (dotted line **B**). Adjustments are made by turning flanges on back feet only.
3. Level consoles individually from front to back (dotted lines **C**). Adjustments are made by turning flanges on front feet only.
4. Re-check that the back is level (dotted line **B**) and then the front (dotted line **D**). Adjust if necessary.

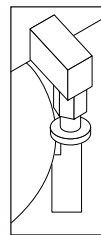

Guide Pins

5. Check that mixer bridge is level and guide pins lock smoothly without binding. If not repeat steps **1** through **4**.

NOTE: See Operating Instructions before operating unit.

6. Make electrical connections (see electrical service connections) and test mixer bridge as follows:
 - ⇒ **A/** Raise mixer bridge.
 - ⇒ **B/** Swing bridge out over centre console.

- ⇒ **C/** Swing bridge to the left as far as possible.
- ⇒ **D/** Lower bridge.
- ⇒ **E/** Bridge pins should enter pin hole on kettle perfectly, If not return to step 1 and repeat leveling steps.
- ⇒ **F/** Raise bridge and swing to far right (for twin mixers only).
- ⇒ **G/** Repeat steps **D** and **E** (for twin mixers only).

7. Once positioned and leveled, permanently secure the kettle's flanged feet to the floor using 5/16 inch stainless steel lag bolts and floor anchors (supplied by the installer). Secure each of the flanged feet with one bolt in each hole. Seal joints of flanged feet with a silicone sealant.

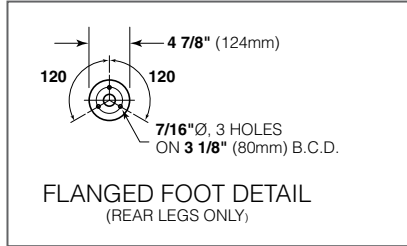

COMPRESSED AIR CONNECTION

Mixer Kettles with an air activated discharge valve require a minimum of 90 PSI to operate correctly.

If the unit is also supplying air to a Metering Filling Station then a pressure of 100 PSI at a minimum volume of 25 CFM is required.

The air supplied to the mixer should be clean and dry. No oil should be added to the supply air. We recommend the compressed air system be equipped with a drier, filter, and automatic water dump on the air compressor receiver tank. If the distance between the tank and the unit is less than 100 feet then a minimum line size of 3/4" is required. A distance of 100 to 300 feet requires a minimum 1" line.

ELECTRICAL SERVICE CONNECTIONS

ENSURE THE ELECTRICAL SUPPLY MATCHES THE KETTLE'S REQUIREMENTS AS STATED ON THE RATING LABEL.

Install in accordance with local codes and/or the National Electric Code ANSI/NFPA No 70-1981 (USA) or the Canadian Electric Code CSA Standard C22.1 (Canada). A separate fused disconnect switch must be supplied and installed. The kettle must be electrically grounded by the installer.

The electric supply must match the power requirements specified on the kettle's rating plate. The copper wiring must be adequate to carry the required current at the rated voltage.

1. Ensure main power is turned off before connecting wires.
2. Remove the screws at the rear of the mixer console cover, and remove the cover. A wiring diagram is affixed to the underside of the console cover.
3. Feed permanent copper wiring 18" through the cut-out in the bottom of the console. Connect wiring in junction box in the bottom of the console.
4. Turn main power back on.
5. Check for correct rotation of electric motor (access by removing top front cover on center console). If rotation is incorrect, disconnect main power and reverse any two of the three live lines.
6. Replace the console cover and secure it with screws.

QUALITY ASSURANCE CHECKS

INSTALLATION

1. Visual Examine unit for scratches, dents, or other defects.
2. Visual Check flanged feet all have bolts holding them.
3. General Check all accessible wiring, mechanical and plumbing connections by hand for secure, tight and satisfactory assembly. Remove all paper.
4. Level Check unit has been leveled and squared correctly.

KETTLE

Although the kettle has been thoroughly tested before leaving the factory, the installer is responsible for ensuring the proper operation of kettle once installed.

DO NOT ATTEMPT TO OPERATE THIS APPLIANCE DURING A POWER FAILURE.

KEEP APPLIANCE AND AREA FREE AND CLEAR OF COMBUSTIBLES.

1. Before turning the kettle on, read the vacuum/pressure gauge. The gauge's needle should be in the green zone. If the needle is in the "VENT AIR" zone, follow air venting procedure.
2. Supply power to the kettle by placing the fused disconnect switch to the "ON" position.
3. Turn on main gas supply to unit. Open the kettle's shut-off valve (located at back of console).
4. Turn the temperature control knob to "1" (Min.). The green LED light should remain lit, indicating the burner is lit, until the set temperature is reached. Then the green light will cycle on and off, indicating the burner is cycling on and off to maintain temperature.
5. Tilt the kettle forward. After a few seconds the red "LOW WATER" light should be lit when the kettle is in a tilted position. This light indicates that the burner has automatically been shut off by the kettle's safety circuit. This is a normal condition when the kettle is in a tilted position.
6. Raise the kettle to the upright position. The red "LOW WATER" light should go out when the kettle is upright.
7. Turn the temperature control knob to "10" (Max.) and allow the kettle to preheat. The green light should remain on until the set temperature is reached. Then the green light will cycle ON and OFF, indicating the burner is cycling ON and OFF to maintain temperature



MIXER

1. Raise Bridge If bridge does not raise then check motor rotation. Bridge should not raise until speed control is turned to minimum and then adjusted back up.
2. Swing Bridge Bridge when fully raised should swing without hitting any object, i.e. control housing, kettle lip. Check that hydraulic hoses are not being pinched by stops on swivel assembly.
3. Tilt Kettle Kettle tilts smoothly both down and back up. If power tilt, check that micro switches are adjusted properly (kettle is level in upright position and drains fully when tilted) and are not being crushed by gear.
4. Lower Bridge Raise bridge. Switch to mix. Turn speed control to zero to reset micro switch then set speed control to number four. Check that unit does not begin to mix until bridge has lowered part way into the kettle. Check that mixer bridge pin lowers into pin hole correctly
5. Speed Control - Main Main agitator arm not rotating when set at "0" but will start to move slowly on "1" . Speed control makes positive contact with micro switch.
6. Speed Control - Secondary Set main speed control to five. Adjust secondary control from minimum to maximum. Look for considerable speed variance.
7. Water Faucets Turn on hot water faucet. Turn off and check for leaks in piping and drips from faucet spout. Repeat above with cold water faucet.
8. Product Discharge Valve Add water to kettle. Check for leaks from valve. Open and close valve a few times and check for leaks again.

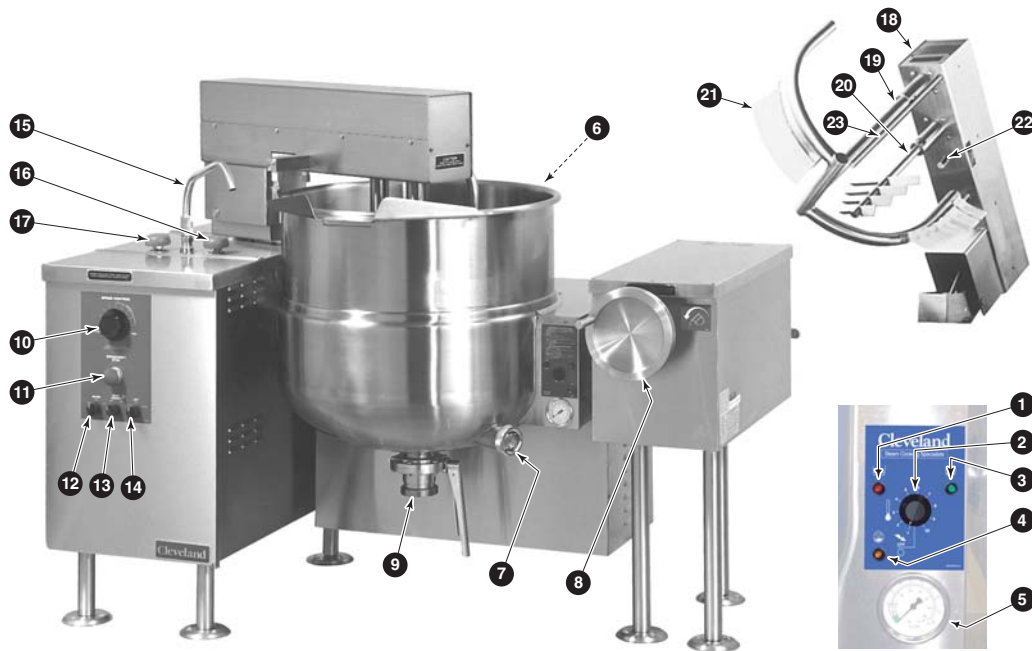
OPERATING INSTRUCTIONS



Operating Controls & Indicators

ITEM #	DESCRIPTION	FUNCTION
1.	 Low Water Indicator Light (Red)	When lit, indicates that the kettle is low on water and will not operate in this condition. This will also light when the kettle is tilted.
2.	On-Off Switch/ Solid State Temperature Control	Turns kettle ON/OFF and allows the operator to adjust the kettle temperature in increments from 1 (Min.) to 10 (Max.).
3.	 Heat Indicator Light (Green)	When lit, indicates that the kettle's burner is on. Cycles ON-OFF with burner.
4.	 Ignition Failure Indicator Light (Amber)	Indicates failure of heating system to ignite. (Used prior to July 2004)
5.	Vacuum/Pressure Gauge	Indicate steam pressure in PSI inside steam jacket as well as vacuum in inches of mercury.
6.	Pressure Relief Valve (not shown)	This valve is used to vent the kettle and in the unlikely event there is an excess steam build-up in the jacket, this valve opens automatically to relieve this pressure.
7.	Water Level Sight Glass	Displays water level in steam jacket.
8.	Tilt Wheel	Used for tilting the kettle on hand tilt models. In power tilt models there is a toggle switch in same location.
9.	Butterfly Valve	Used for draining product or wash water from kettle.
10.	Mixer Speed Control	Controls speed of agitators and mixer bridge lift mode.
11.	Emergency Stop	Stops hydraulic system.
12.	Main Power Switch	Power switch for unit.
13.	Mix/Lift Switch	Sets hydraulics to mix or lift mode.
14.	Up/Down Switch	When unit is in lift mode, bridge can be raised or lowered with this switch.
15.	Faucet Spout	Delivers water to the kettle.
16.	Cold Water Valve	Turns on cold water.
17.	Hot Water Valve	Turns on hot water.
18.	Mixer Bridge	Encloses agitator motors.
19.	Main Agitator Arm	Provides most of the product movement.
20.	Secondary Arm	Provides reverse agitation and product lift in kettle.
21.	Scraper Blades	Scrapes the side of the kettle and moves product away.
22.	Secondary Speed Control	Controls speed of secondary agitator arm.
23.	Temperature Probe	Probe holds temperature sensors for controller.

OPERATING THE KETTLE



Do not attempt to operate this appliance during a power failure. Keep appliance and area free and clear of combustibles.

Do not lean on or place objects on kettle lip. Serious injury could result if kettle tipped over, spilling hot contents.

If you are cooking an egg or milk product, do not pre-heat kettle.

Cooking

1. Before turning kettle on, read the Vacuum/Pressure Gauge (5). The gauges needle should be in the green zone. Once heated, the kettle's normal maximum operating pressure is approximately 10-12 psi while cooking a water base product.
2. Ensure that the electrical service to the kettle is turned on at the fused disconnect switch.

Temperature Control Setting	Approximate Product Temperature	
	°F	°C
1.	120	49
2.	135	57
3.	150	66
4.	165	74
5.	180	82
6.	195	91
7.	210	99
8.	225	107
9.	245	118
10.	265	130

NOTE: Certain combinations of ingredients will result in temperature variations.

Temperature Range Chart

3. Preheat the kettle by turning the ON/OFF Switch/Solid State Temperature Control (2) to the desired temperature setting (see above "Temperature Range Chart"). The Heat Indicator Light (Green) (3) will remain lit, indicating the burner is on, until the temperature setting is reached. When the green light goes off, the burners are off, and preheating is complete.

NOTE: When cooking egg and milk products, the kettle should not be preheated, as products of this nature adhere to hot cooking surfaces. These types of food should be placed in the kettle before heating is begun.

4. Place food product into the kettle. The green Heat Indicator Light (3) will cycle on and off indicating the burners are cycling on and off to maintain the set temperature.



NOTE: Do not fill kettle above recommended level marked on outside of kettle.

NOTE: The red Low Water Indicator Light (1) should not be lit when the kettle is in the upright position during kettle operation. This light indicates that the burners have been automatically shut off by the kettle's safety circuit. It is, however, normal for the red light to come on when the kettle is in a tilted position.

5. When cooking is completed turn On/Off Switch/Solid State Temperature Control (2) to the "OFF" position.

NOTE: A five minute complete shut-of period is required before relighting.

6. Pour the contents of the kettle into an appropriate container by tilting the kettle forward. Care should be taken to pour slowly enough to avoid splashing off the product.

NOTE: As with cleaning food soil from any cookware, an important part of kettle cleaning is to prevent food from drying on. For this reason, cleaning should be completed immediately after cooked foods are removed.

Approximate Boiling Times

The accompanying chart shows approximate times required for gas kettles of various capacities to boil water with the lid open. The ON/OFF Switch/Solid State Temperature Control (2) must be set at "10" throughout the heat-up period. Water will boil about 1/3 faster if the kettle is filled only to the outer steam jacket's welded seam resulting in a kettle filled to 2/3 capacity.

Kettle Capacity	Minutes
40 gallon	35
60 gallon	47
80 gallon	60
100 gallon	75

Approximate Boiling Times

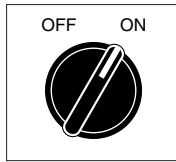

General Operation

1. Turn MAIN POWER SWITCH (12) to "ON".

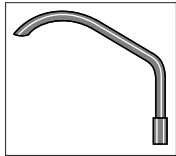

Adding Water Manually

1. Locate FAUCET SPOUT (15) over desired kettle.
2. Turn on HOT or COLD WATER VALVES (16 or 17).

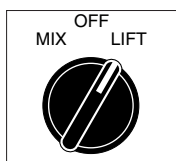
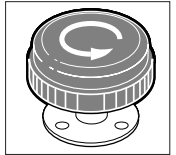

Lifting & Lowering Bridge

WARNING- Insure FAUCET SPOUT (15) is out of way before raising or lowering bridge.

1. Turn MIX/LIFT SWITCH (13) to "LIFT".
2. Turn MIXER SPEED CONTROL (10) to "MIN" and back up to #5.
3. Turn and hold UP/DOWN SWITCH (14) "UP" to raise or "DOWN" to lower.

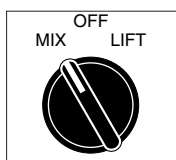
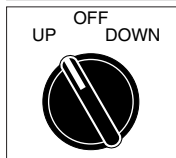
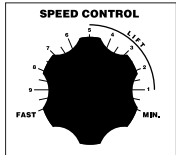

Mixing

1. Turn MIX/LIFT SWITCH (14) to "MIX".
2. Turn MIXER SPEED CONTROL (10) to "MIN" and slowly adjust to desired speed.
3. Adjust SECONDARY SPEED CONTROL (22) to desired speed.

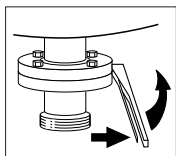
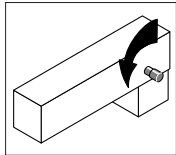
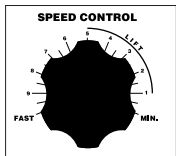

Discharge Valve

2. Push handle in and pull upwards to open.

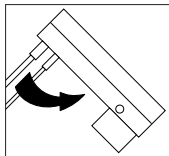

Tilting Kettle

1. Raise MIXER BRIDGE (18) and swing to side.
2. For **manual tilt**: turn TILT WHEEL (8).
3. For **power tilt**: turn switch "↑" to raise, or "↓" to tilt.

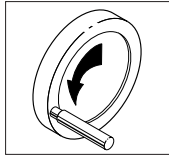

WARNING- Do not tilt kettle when mixer agitators are in kettle bowl.

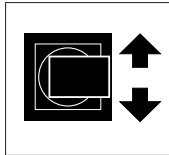

OPERATING SUGGESTIONS

Cleveland Range Mixer Kettles are simple and safe to operate. The following tips will allow you to maximize the use of your new mixer.

1. Allow unit to preheat before addition of product to kettle. However when cooking egg and milk products, the kettle should NOT be preheated, as products of this nature adhere to hot cooking surfaces. These types of foods should be placed in the kettle before heating is begun.
2. An important part of kettle cleaning is to prevent foods from drying on. For this reason, cleaning should be completed immediately after cooked foods are removed.
3. If a mixer bridge is equipped with a temperature probe for a controller or thermometer, the probe must be submerged a minimum of three inches in the product for accurate readings.

Safety

1. Close BUTTERFLY VALVE (9) before filling the kettle.
2. When raising or lowering MIXER BRIDGE (18), insure FAUCET SPOUT (15) is not in the way of MAIN AGITATOR ARM (19) or damage to spout will result.
3. As a safety precaution the MIXER SPEED CONTROL (10) must first be turned to zero before unit will start to mix.
4. Always remember, like a cooking pot the kettles become very hot when cooking. Avoid contact with bare skin.



CLEANING INSTRUCTIONS



CARE AND CLEANING

Cooking equipment must be cleaned regularly to maintain its fast, efficient cooking performance and to ensure its continued safe, reliable operation. The best time to clean is shortly after each use (allow unit to cool to a safe temperature).

WARNINGS

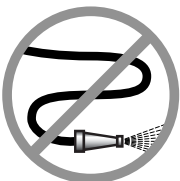
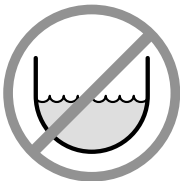
- ⇒  Do not use detergents or cleansers that are chloride based or contain quaternary salt.
Chloride Cleaners
- ⇒  Do not use a metal bristle brush or scraper.
Wire Brush &
- ⇒  Steel wool should never be used for cleaning the stainless steel.
Steel Pads
- ⇒  Unit should never be cleaned with a high pressure spray hose.
High Pressure Spray Hose
- ⇒  Do not leave water sitting in unit when not in use.
Stagnant Water

CLEANING INSTRUCTIONS

1. Turn unit off.
2. Remove drain screen (if applicable). Thoroughly wash and rinse the screen either in a sink or a dishwasher.
3. Prepare a warm water and mild detergent solution in the unit.
4. Remove food soil using a nylon brush.
5. Loosen food which is stuck by allowing it to soak at a low temperature setting.
6. Drain unit.
7. Rinse interior thoroughly.
8. If the unit is equipped with a **Tangent Draw-Off Valve**, clean as follows:
 - a) Disassemble the draw-off valve first by turning the valve knob counter-clockwise, then turning the large hex nut counter-clockwise until the valve stem is free of the valve body.
 - b) In a sink, wash and rinse the inside of the valve body using a nylon brush.
 - c) Use a nylon brush to clean tangent draw-off tube.
 - d) Rinse with fresh water.
 - e) Reassemble the draw-off valve by reversing the procedure for disassembly. The valve's hex nut should be hand tight only.
9. If the unit is equipped with a **Butterfly Valve**, clean as follows:
 - a) Place valve in open position.
 - b) Wash using a warm water and mild detergent solution.
 - c) Remove food deposits using a nylon brush.
 - d) Rinse with fresh water.
 - e) Leave valve open when unit is not in use.
10. Using mild soapy water and a damp sponge, wash the exterior, rinse, and dry.

NOTES

- ⇒ For more difficult cleaning applications one of the following can be used: alcohol, baking soda, vinegar, or a solution of ammonia in water.
- ⇒ Leave the cover off when the kettle is not in use.
- ⇒ For more detailed instructions refer to the Nafem Stainless Steel Equipment Care and Cleaning manual (supplied with unit).

STAINLESS STEEL EQUIPMENT CARE AND CLEANING

(Supplied courtesy of Nafem. For more information visit their web site at www.nafem.org)

Contrary to popular belief, stainless steels ARE susceptible to rusting.

Corrosion on metals is everywhere. It is recognized quickly on iron and steel as unsightly yellow/orange rust. Such metals are called "active" because they actively corrode in a natural environment when their atoms combine with oxygen to form rust.

Stainless steels are passive metals because they contain other metals, like chromium, nickel and manganese that stabilize the atoms. 400 series stainless steels are called ferritic, contain chromium, and are magnetic; 300 series stainless steels are called austenitic, contain chromium and nickel; and 200 series stainless, also austenitic, contains manganese, nitrogen and carbon. Austenitic types of stainless are not magnetic, and generally provide greater resistance to corrosion than ferritic types.

With 12-30 percent chromium, an invisible passive film covers the steel's surface acting as a shield against corrosion. As long as the film is intact and not broken or contaminated, the metal is passive and stain-less. If the passive film of stainless steel has been broken, equipment starts to corrode. At its end, it rusts.

Enemies of Stainless Steel

There are three basic things which can break down stainless steel's passivity layer and allow corrosion to occur.

1. Mechanical abrasion
2. Deposits and water
3. Chlorides

Mechanical abrasion means those things that will scratch a steel surface. Steel pads, wire brushes and scrapers are prime examples.

Water comes out of the faucet in varying degrees of hardness. Depending on what part of the country you live in, you may have hard or soft water. Hard water may leave spots, and when heated leave deposits behind that if left to sit, will break down the passive layer and rust stainless steel. Other deposits from food preparation and service must be properly removed.

Chlorides are found nearly everywhere. They are in water, food and table salt. One of the worst chloride perpetrators can come from household and industrial cleaners.

So what does all this mean? Don't Despair!

Here are a few steps that can help prevent stainless steel rust.

1. Use the proper tools.

When cleaning stainless steel products, use non-abrasive tools. Soft cloths and plastic scouring pads will not harm steel's passive layer. Stainless steel pads also can be used but the scrubbing motion must be in the direction of the manufacturers' polishing marks.

2. Clean with the polish lines.

Some stainless steel comes with visible polishing lines or "grain." When visible lines are present, always scrub in a motion parallel to the lines. When the grain cannot be seen, play it safe and use a soft cloth or plastic scouring pad.

3. Use alkaline, alkaline chlorinated or non-chloride containing cleaners.

While many traditional cleaners are loaded with chlorides, the industry is providing an ever-increasing choice of non-chloride cleaners. If you are not sure of chloride content in the cleaner used, contact your cleaner supplier. If your present cleaner contains chlorides, ask your supplier if they have an alternative. Avoid cleaners containing quaternary salts; it also can attack stainless steel and cause pitting and rusting.

4. Treat your water.

Though this is not always practical, softening hard water can do much

to reduce deposits. There are certain filters that can be installed to remove distasteful and corrosive elements. To insure proper water treatment, call a treatment specialist.

5. Keep your food equipment clean.

Use alkaline, alkaline chlorinated or non-chloride cleaners at recommended strength. Clean frequently to avoid build-up of hard, stubborn stains. If you boil water in stainless steel equipment, remember the single most likely cause of damage is chlorides in the water. Heating cleaners that contain chlorides have a similar effect.

6. Rinse, rinse, rinse.

If chlorinated cleaners are used, rinse and wipe equipment and supplies dry immediately. The sooner you wipe off standing water, especially when it contains cleaning agents, the better. After wiping equipment down, allow it to air dry; oxygen helps maintain the stainless steel's passivity film.

7. Never use hydrochloric acid (muriatic acid) on stainless steel.

8. Regularly restore/passivate stainless steel.

Recommended cleaners for specific situations

Job	Cleaning Agent	Comments
Routine cleaning	Soap, ammonia, detergent, Medallion	Apply with cloth or sponge
Fingerprints & smears	Arcal 20, Lac-O-Nu Ecoshine	Provides barrier film
Stubborn stains & discoloration	Cameo, Talc, Zud, First Impression	Rub in direction of polish lines
Grease & fatty acids, blood, burnt-on-foods	Easy-off, De-Grease It Oven Aid	Excellent removal on all finishes
Grease & oil	Any good commercial detergent	Apply with sponge or cloth
Restoration/Passivation	Benefit, Super Sheen	

Review

1. Stainless steels rust when passivity (film-shield) breaks down as a result of scrapes, scratches, deposits and chlorides.
2. Stainless steel rust starts with pits and cracks.
3. Use the proper tools. Do not use steel pads, wire brushes or scrapers to clean stainless steel.
4. Use non-chlorinated cleaners at recommended concentrations. Use only chloride-free cleaners.
5. Soften your water. Use filters and softeners whenever possible.
6. Wipe off cleaning agent(s) and standing water as soon as possible. Prolonged contact causes eventual problems.

To learn more about chloride-stress corrosion and how to prevent it, contact the equipment manufacturer or cleaning materials supplier.

Developed by Packer Engineering, Naperville, Ill., an independent testing laboratory.

SERVICE PARTS

WARRANTY

Our Company supports a worldwide network of Maintenance and Repair Centers. Contact your nearest Maintenance and Repair Centre for replacement parts, service, or information regarding the proper maintenance and repair of your cooking equipment

In order to preserve the various agency safety certification (UL, NSF, ASME/Ntl. Bd., etc.), only factory-supplied replacement parts should be used. The use of other than factory supplied replacement parts will void warranty.

WRAP COVERS

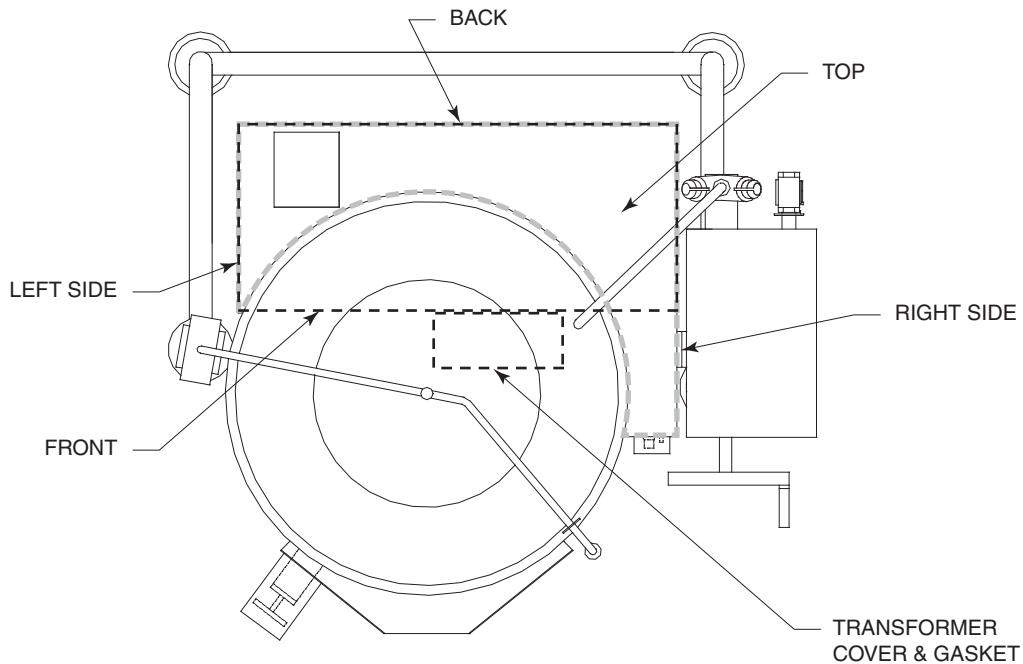

KETTLE	TOP	FRONT	LEFT SIDE	RIGHT SIDE	BACK
KGL-40	KE01479	KE53483-4	KE54253	KE01432	KE02186-1
KGL-60	KE01479-1	KE53483-5	KE54253-1	KE01432-1	KE02186-2
KGL-80	KE01479-2	KE53483-6	KE54253-2	KE01432-2	KE02186-3
KGL-100	KE01479-3	KE53483-7	KE54253-3	KE01432-3	KE02186-4
KGL-40-T	KE01479	KE53483	KE54253	KE01432	KE02186-1
KGL-60-T	KE01479-1	KE53483-1	KE54253-1	KE01432-1	KE02186-2
KGL-80-T	KE01479-2	KE53483-2	KE54253-2	KE01432-2	KE02186-3
KGL-40-SH	KE01479-4	KE53483-6	KE54253-2	KE01432-2	KE02186-3
KGL-60-SH	KE01479-5	KE53483-7	KE54253-3	KE01432-3	KE02186-4
KGL-40-TSH	KE01479-4	KE53483-2	KE54253-2	KE01432-2	KE02186-3

PRESSURE RELIEF ASSEMBLY

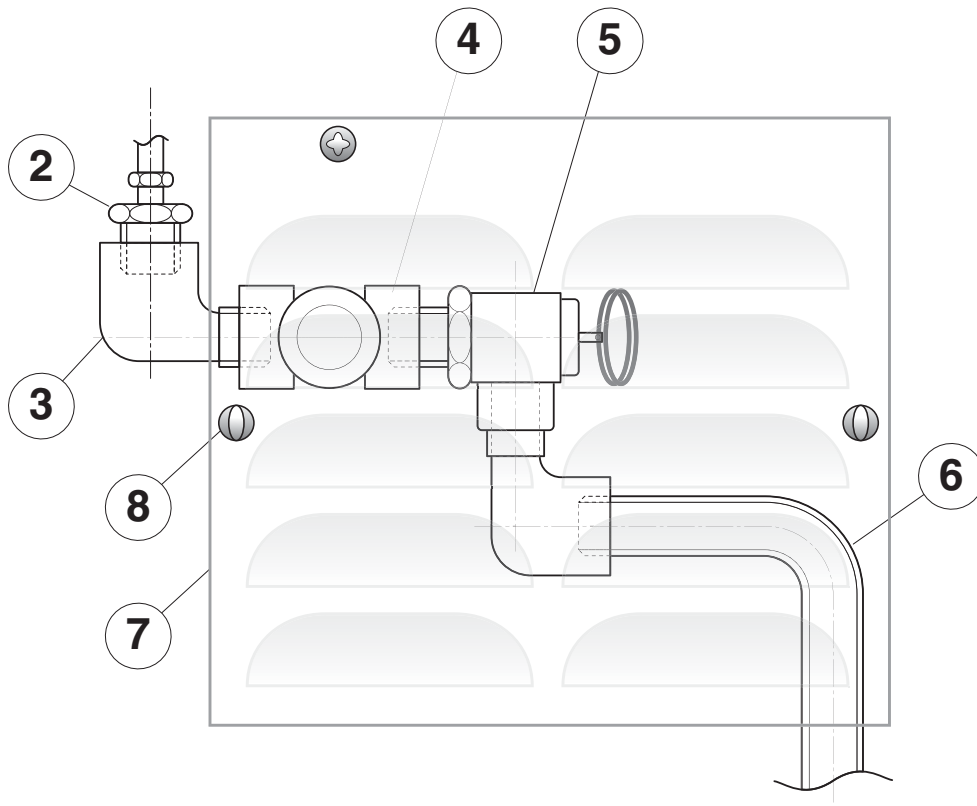
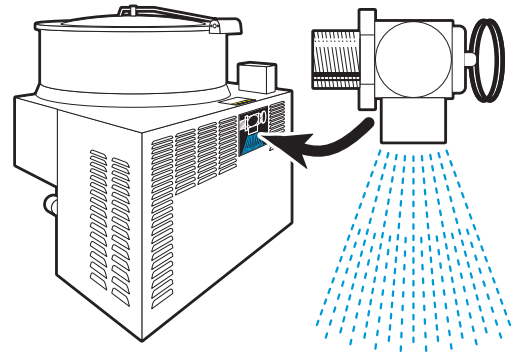

ITEM NO.	PART NO.	DESCRIPTION	QTY.
		<i>PRESSURE RELIEF VALVE ASSEMBLIES</i>	
1.	KE01450	FOR ASME KETTLES (INCLUDES #2-6)	1
	KE01450-1	FOR CE KETTLES (INCLUDES #2-6)	1
2.	FA05049	MALE CONNECTOR, 1/2" PIPE - 1/4" TUBE	1
3.	FI00151	STREET ELBOW, 90°, 1/2", BRASS	2
4.	FI00178	TEE, 1/2" FPT, BRASS	1
		<i>SAFETY VALVES</i>	
5.	KE54941-5	SAFETY VALVE, 50 PSI, 1/2" (NORTH AMERICA)	1
	KE54941-31	SAFETY VALVE, 50 PSI, 1/2", (EUROPE)	1
6.	KE54223	BLOW DOWN TUBE	1
7.	KE54864	ACCESS PANEL	1
8.	FA11518-4	THUMB SCREW, 10-32 X 1/2" L	1

HYDRAULIC COMPONENTS

Scraper Blades:



KETTLE SIZE

GALLONS	QUANTITY
40	22
60	26
80	30
100	34
125	38
150	38



Cooling Fan:

Fan KE54860
 Fan Cover ... KE601236
 Fan Guard ... KE54861

NOTE: For Hydraulic Hoses order Part No. RT00505 and specify length required

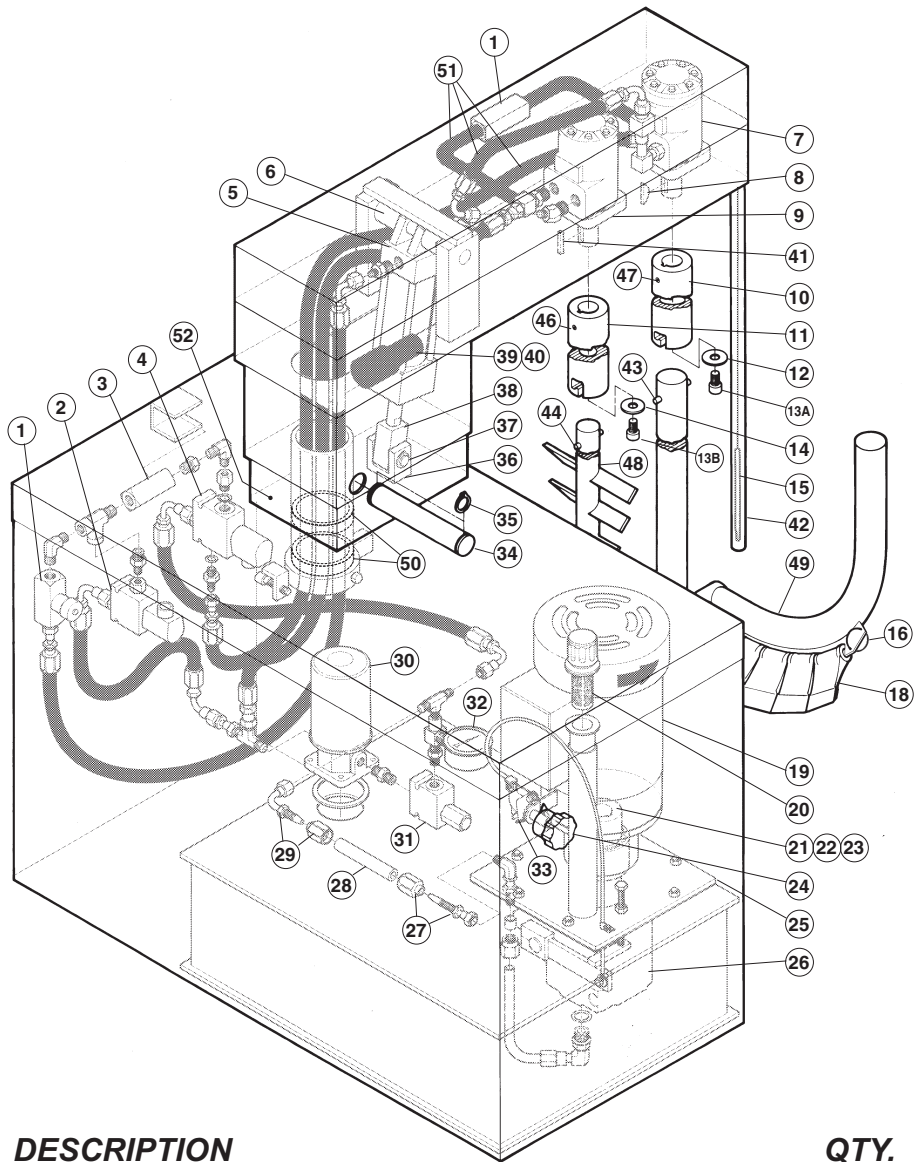

ITEM NO.	PART NO.	DESCRIPTION	QTY.
1.	KE51607	Flow Control Valve	.2
2.	KE54834-10	Solenoid Valve, 2 Way, 120 Volt	.1
	SE50224	Coil Only 120 Volt	.1
3.	KE51608	Check Valve	.1
4.	KE54834-11	Solenoid Valve, 3 Way, 120 Volt	.1
	SE50224	Coil Only 120 Volt	.1
5.	KE51848	Jack	.1
	SE50241	Rod Gland Seal Kit	.1
	SE50242	Piston Seal Kit	.1
6.	KE52124	Jack Upper Pin	.1
7.	KE51846	Hydraulic Motor, Scraper Arm, 40 gal.	.1
	KE51938	Hydraulic Motor, Scraper Arm, 60-150 gal.	
	KE53004	Hydraulic Motor, Scraper Arm, 200-250 gal.	
8.	FA95006	Woodruff Key	.1
9.	KE51845	Hydraulic Motor, Secondary Agitator, 40-150 gal.	.1
	KE53005	Hydraulic Motor, Secondary Agitator, 200-250 gal.	
10.	KE51715	Main Coupling, Scraper Arm	.1
11.	KE51716	Secondary Coupling, Agitator Arm	.1
12.	KE52114	Coupling Washer, Primary S.S.	.1
13A.	FA11286	Socket Head Screw, 1/4 X 20	.2
13B.	FA11346	Socket Head Screw, 5/16 X 20	.2
14.	KE52115	Coupling Washer, Secondary S. S.	.1
15.	CT50097	R.T.D Probe Single	.1
16.	KE53962	Blade Stop Ring	.2

18.	KE51834	Scraper Blades	as required
19.	KE51875-3	Electric Motor, 3 hp., 208-230/460V	1
	KE51875-4	Electric Motor, 3 hp., 220/380/440V	1
	KE51875-5	Electric Motor, 3 hp., 575V	1
20.	KE51889	Filter, Tank Breather	1
21.	KE52222	Gear, 3/4" I.D. Pump, prior to 1995	1
21.	KE52222-1	Gear, 3/4" I.D. Pump, after 1995	1
22.	KE52223	Gear, 7/8" I.D. Motor	1
23.	KE52224	Nylon Coupling.	1
24.	KE52190	Speed Control Knob	1
25.	KE52171	Gasket, Oil Tank	1
26.	KE51844	Hydraulic Pump	1
27.	FI05060	Swivel adapter	5
28.	SE50280	Hydraulic Hose, Per Foot	40
29.	FI05061	Swivel Elbow, 90 Degrees	9
30.	SE50094	Oil Filler	1
31.	KE51874	Pressure Relief Valve, Hydraulic	1
32.	KE52382	Pressure Gauge	1
33.	KE00860	Speed Control Cable Assembly	1
34.	KE51622	Bridge Tilt Pin	1
35.	FA95022	Retaining Ring	1
36.	KE51623	Clevis Bracket	1
37.	SE50353	Clevis Pin c/w Clips	1
38.	KE51624	Knuckle Joint	1
39.	KE50295	Mounting Bracket, Mercury Switch	1
40.	KE50294	Mercury Switch	1-2
41.	FA95055-3	Woodruff Key	1
42.	T40527	Housing, probe, 40 gal.	1
	T40528	Housing, probe, 60 gal.	1
	T40529	Housing, probe, 80 gal.	1
	T40530	Housing, probe, 100 gal.	1
	T40531	Housing, probe, 125 gal.	1
	T40532	Housing, probe, 150 gal.	1
	T405321	Housing, probe, 200 gal.	1
	T405322	Housing, probe, 250 gal.	1
43.	KE51921	Pin, Scraper Arm	1
44.	KE51925	Pin, Secondary Agitator	1
46.	FA19506	Set Screw, Secondary Agitator	1
47.	FA19507	Set Screw, Scraper Arm	1
48.	KE00935	Secondary Agitator, 40 gal. (includes #44)	1
	KE00936	Secondary Agitator, 60 gal. (includes #44)	1
	KE00937	Secondary Agitator, 80 gal. (includes #44)	1
	KE00938	Secondary Agitator, 100 gal. (includes #44)	1
	KE00939	Secondary Agitator, 125 gal. (includes #44)	1
	KE00940	Secondary Agitator, 150 gal. (includes #44)	1
	KE009401	Secondary Agitator, 200 gal. (includes #44)	1
	KE009402	Secondary Agitator, 250 gal. (includes #44)	1
49.	KE00947	Primary Agitator, 40 gal., with Gallon Markings (includes #16, 18 & 43)	1
	KE00948	Primary Agitator, 60 gal., with Gallon Markings (includes #16, 18 & 43)	1
	KE00949	Primary Agitator, 80 gal., with Gallon Markings (includes #16, 18 & 43)	1
	KE00950	Primary Agitator, 100 gal., with Gallon Markings (includes #16, 18 & 43)	1
	KE00951	Primary Agitator, 125 gal., with Gallon Markings (includes #16, 18 & 43)	1
	KE00952	Primary Agitator, 150 gal., with Gallon Markings (includes #16, 18 & 43)	1
	KE009521	Primary Agitator, 200 gal., with Gallon Markings (includes #16, 18 & 43)	1
	KE009522	Primary Agitator, 250 gal., with Gallon Markings (includes #16, 18 & 43)	1
	KE00947-1	Primary Agitator, 40 gal., with Liter Markings (includes #16, 18 & 43)	1
	KE00948-1	Primary Agitator, 60 gal., with Liter Markings (includes #16, 18 & 43)	1
	KE00949-1	Primary Agitator, 80 gal., with Liter Markings (includes #16, 18 & 43)	1
	KE00950-1	Primary Agitator, 100 gal., with Liter Markings (includes #16, 18 & 43)	1
	KE00951-1	Primary Agitator, 125 gal., with Liter Markings (includes #16, 18 & 43)	1
	KE00952-1	Primary Agitator, 150 gal., with Liter Markings (includes #16, 18 & 43)	1
	KE009521-1	Primary Agitator, 200 gal., with Liter Markings (includes #16, 18 & 43)	1
	KE009522-1	Primary Agitator, 250 gal., with Liter Markings (includes #16, 18 & 43)	1
50.	KE52687	Roller Bearing	2
51.	RT00505	Hydraulic Hose	specify length
52.	KE00715	Bridge Swivel Housing Assembly	1

GAS CONTROL ASSEMBLY

Stationary Models

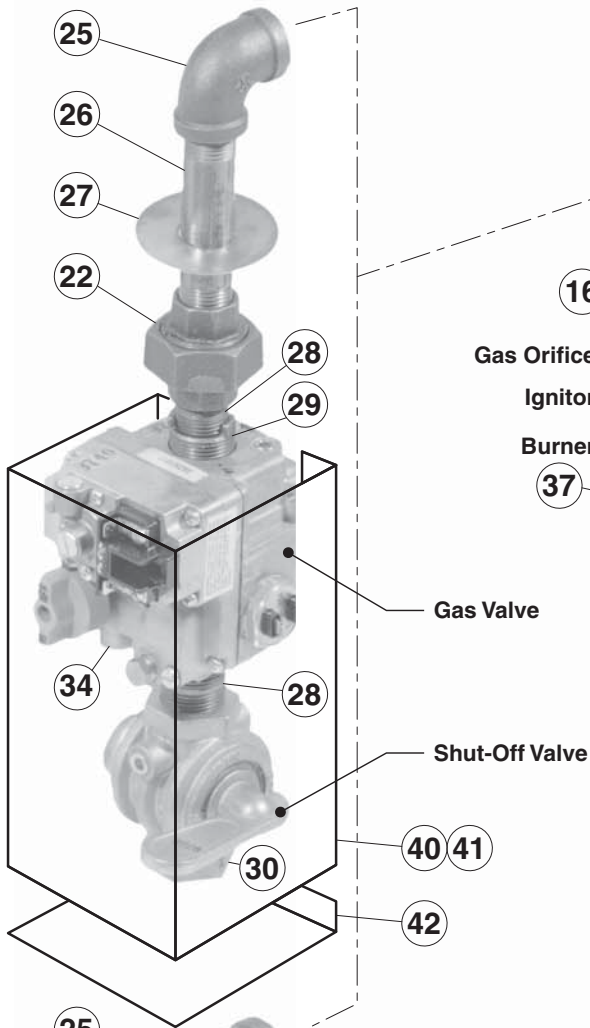

Tilting Models

(for units built prior to March 2005)

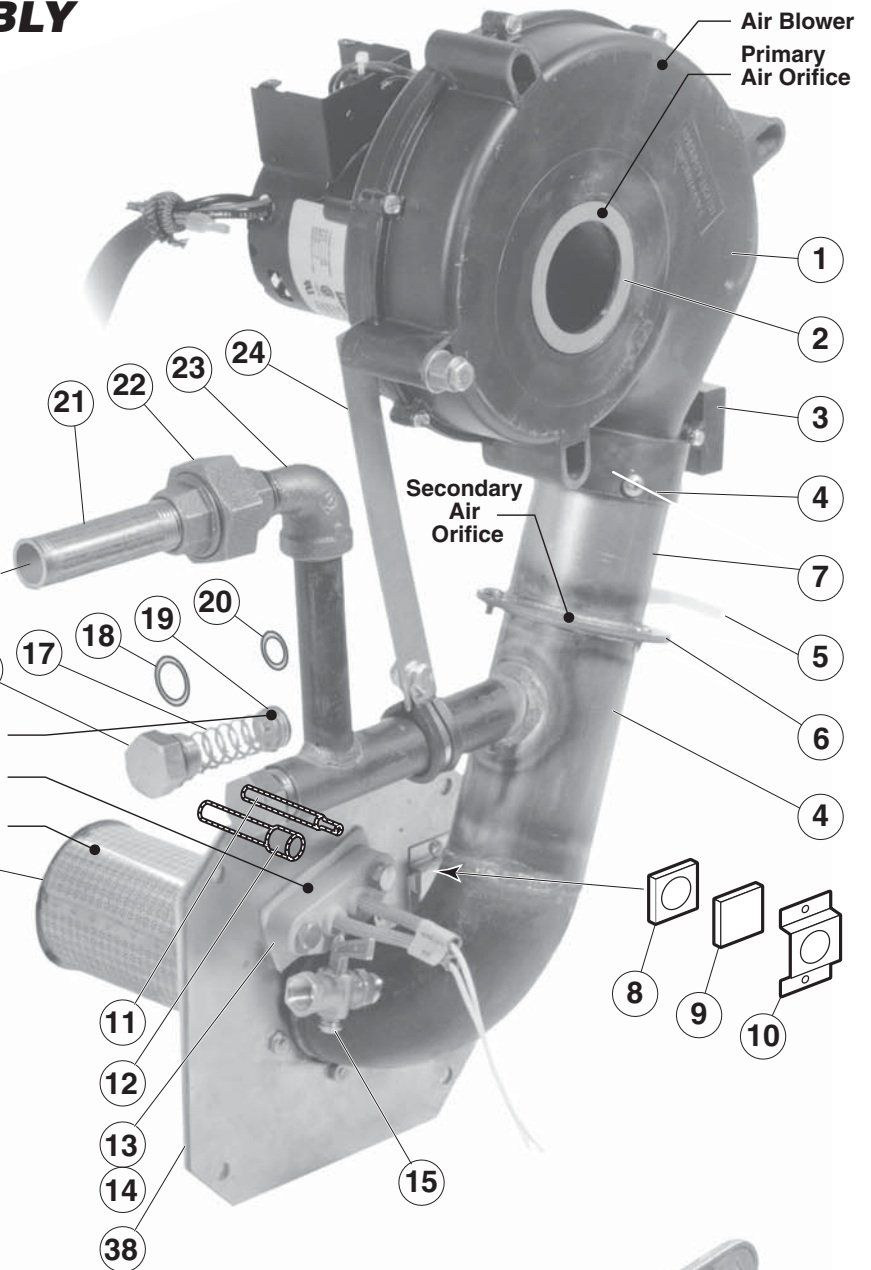
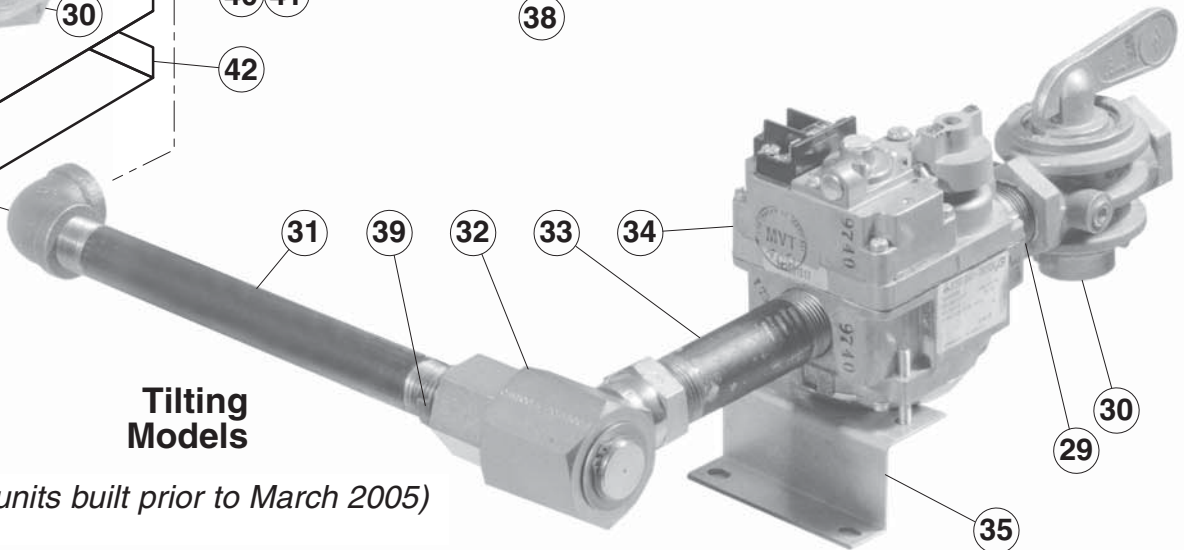

GAS CONTROL ASSEMBLY

ITEM ON.	PART NO.	DESCRIPTION	QTY.
1.	KE53441	BLOWER, 115V, 60 HZ	1
	KE53441-1	BLOWER, 220V, 50 HZ	1
2.	KE54420	AIR INTAKE WASHER (NATURAL GAS)	1
	KE54420-1	AIR INTAKE WASHER (PROPANE)	1
3.	KE54239	CAPACITOR	1
4.	KE01426-4	MIXING CHAMBER, 40 GALLON KETTLES	1
	KE01426-1	MIXING CHAMBER, 60 GALLON KETTLES	1
	KE01426-2	MIXING CHAMBER, 80 GALLON KETTLES	1
	KE01426-3	MIXING CHAMBER, 100 GALLON KETTLES	1
5.	KE53582	TUBING 1/4 INCH SILICONE	1
	FI05156	HOSE FITTING	1
6.	KE53402	AIR ORIFICE, 40 GALLON KETTLES	1
	KE53402-1	AIR ORIFICE, 60 - 100 GALLON KETTLES	1
	KE53402-2	AIR ORIFICE, 40 GALLON KETTLES (50 HZ BLOWER)	1
	KE53402-3	AIR ORIFICE, 60 - 100 GALLON KETTLES (50 HZ BLOWER)	1
7.	KE01449	BLOWER MOUNTING PIPE ASSEMBLY	1
8.	KE53618	SIGHT GLASS GASKET	1
9.	KE53617	SIGHT GLASS	1
10.	KE53619	SIGHT GLASS RETAINER	1
11.	KE00515	THERMISTOR	1
12.	KE50556-2	WATER LEVEL PROBE	1
13.	KE53437-3	IGNITOR	1
14.	KE53570	GASKET FOR IGNITOR	1
15.	FI05257	SHUT-OFF COCK	1
16.	FI05213	PLUG	1
17.	KE53422	SPRING	1
18.	FA05002-4	"O" RING	1
19.	GAS ORIFICES:		
	KE53403-8	NATURAL GAS - SEA LEVEL UP TO 2000', 40 GALLON KETTLES	1
	KE53403-5	PROPANE GAS - SEA LEVEL UP TO 2000', 40 GALLON KETTLES	1
	KE53403-6	NATURAL GAS - SEA LEVEL UP TO 2000', 60 - 100 GALLON KETTLES	1
	KE53403-7	PROPANE GAS - SEA LEVEL UP TO 2000', 60 - 100 GALLON KETTLES	1
	KE53403-8	NATURAL GAS - 2000' UP TO 4000', 40 GALLON KETTLES	1
	KE53403-9	PROPANE GAS - 2000' UP TO 4000', 40 GALLON KETTLES	1
	KE53403-10	NATURAL GAS - 2000' UP TO 4000', 60 - 100 GALLON KETTLES	1
	KE53403-11	PROPANE GAS - 2000' TO 4000', 60 - 100 GALLON KETTLES	1
	KE53403-12	NATURAL GAS - 4000' UP TO 6000', 40 GALLON KETTLES	1
	KE53403-13	PROPANE GAS - 4000' UP TO 6000', 40 GALLON KETTLES	1
	KE53403-10	NATURAL GAS - 4000' UP TO 6000', 60 - 100 GALLON KETTLES	1
	KE53403-14	PROPANE GAS - 4000' UP TO 6000', 60 - 100 GALLON KETTLES	1
20.	FA05002-29	"O" RING	1
21.	FI05226-4	NIPPLE, 1/2" NPT, 5 5/16" LONG	1
22.	FI00073	UNION, 1/2"	1
23.	FI00133	ELBOW, 1/2", STREET	1
24.	KE93909	STRIP, TO HOLD BLOWER DOWN	1
25.	FI00040-1	ELBOW, 1/2"	1
26.	FI00579	NIPPLE, 1/2" NPT, 4" LONG, KGL-60-T	1
	FI05226-2	NIPPLE, 1/2" NPT, 4" LONG, KGL-80-T	1
27.	KE55004-3	RETAINING PLATE	1
28.	FI00573	NIPPLE, 1/2" NPT, 1 1/8" LONG	1
29.	FI05231	BUSHING, 3/4 - 1/2" NPT FLUSH, BLACK IRON	1
30.	F01518-1	GAS SHUT-OFF VALVE, 3/4" (NOT FOR FRENCH CE KETTLES)	1
31.	FI05226	NIPPLE, 1/2" NPT, 8" LONG	1
32.	FI05222	SWIVEL ELBOW	1
33.	FI05223	SPECIAL NIPPLE	1
34.	KE02053	GAS VALVE ASSEMBLY	1
35.	KE53390	BRACKET FOR GAS VALVE	1
36.	FI00607	NIPPLE, 3/4" NPT, 1 1/2" LONG	1
37.	KE01500-5	BURNER, 40 GALLON KETTLES, 140,000 BTU	1
	KE01500-1	BURNER, 60-100 GALLON KETTLES, 190,000 BTU	1
38.	KE53397	GASKET, BURNER	1
39.	FI05231	ADAPTOR	1
40.	KE601085	COVER FOR GAS VALVE	1
41.	RB018151	GASKET FOR COVER	1
42.	KE601081	BRACKET	1

GAS CONTROL ASSEMBLY

(for units built after February 2005)

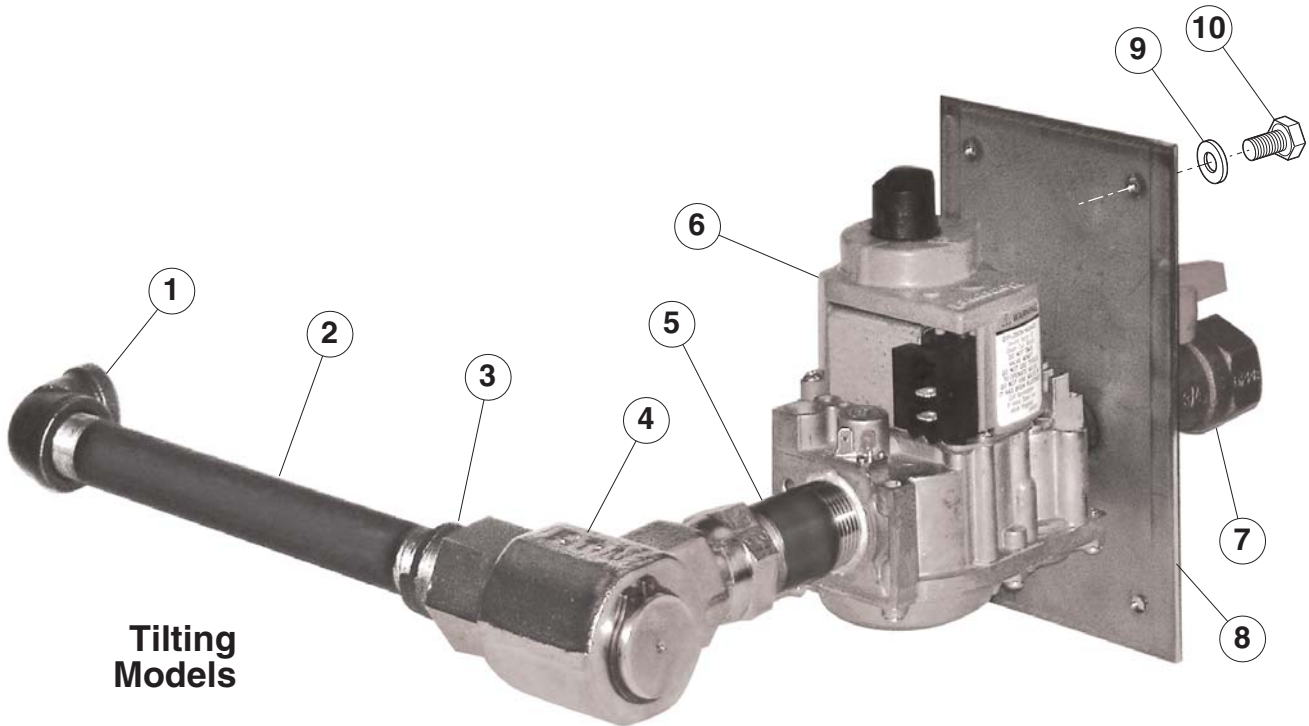

**Tilting
Models**

1.	FI00040-1	ELBOW, 1/2"	1
2.	FI05226	NIPPLE, 1/2" NPT, 8" LONG	1
3.	FI05231	ADAPTOR	1
4.	FI05222	SWIVEL ELBOW	1
5.	FI05223	SPECIAL NIPPLE	1
6.	KE55240R	GAS VALVE	1
7.	F015	GAS SHUT-OFF VALVE, 3/4"	1
8.	KE000960	NIPPLE PLATE WELDMENT	1
9.	FA30505-1	WASHER, 1/4"	4
10.	FA11256	HEX BOLT, 1/4-20 X 1/2, 18-8 SS	4

GEARBOX ASSEMBLY

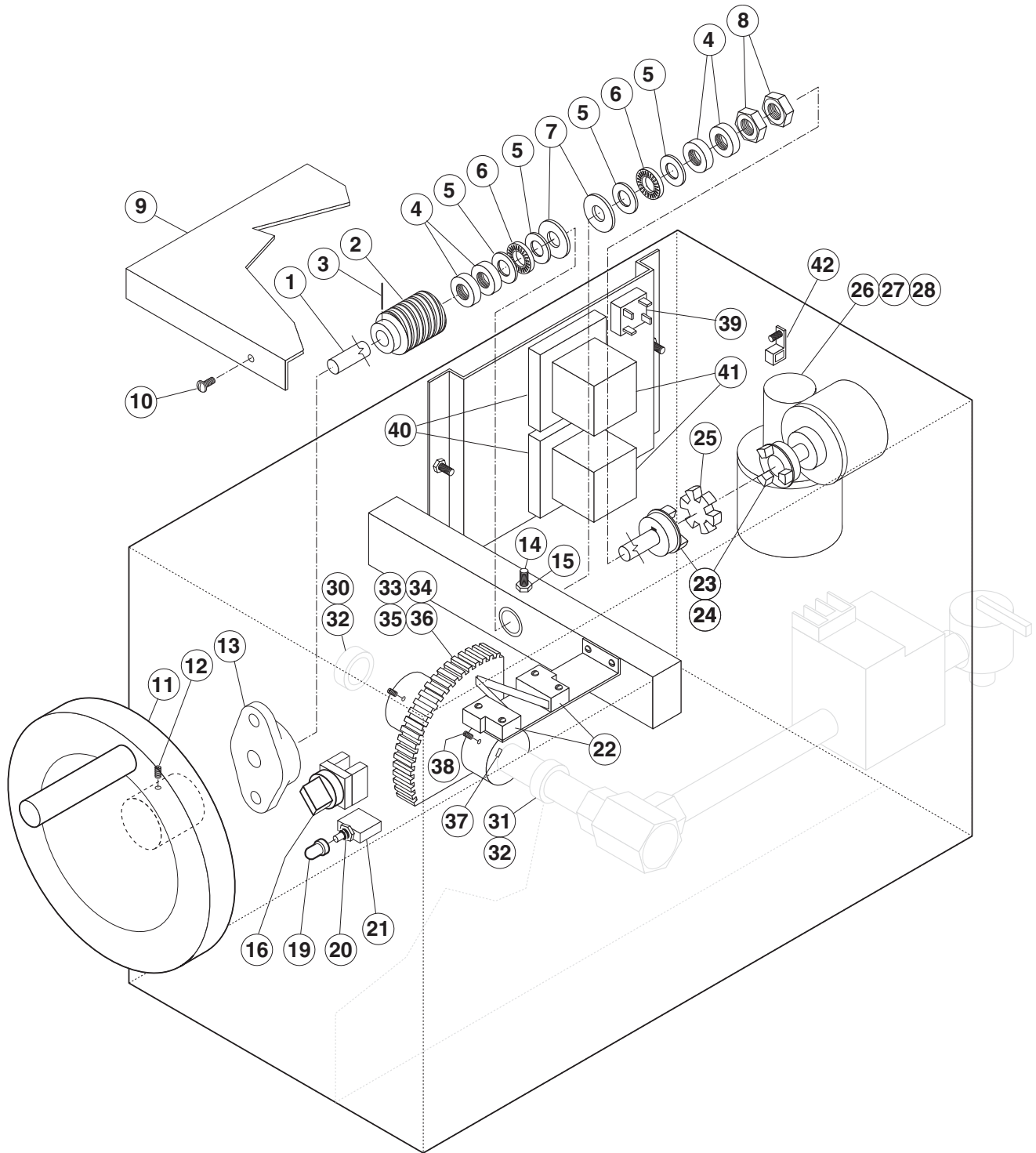

GEARBOX ASSEMBLY

ITEM NO.	PART NO.	DESCRIPTION	QTY.
1.	KE54644	TILT SHAFT, MANUAL TILT	1
	KE52836-2	TILT SHAFT, POWER TILT	1
2.	KE50315	WORM	1
3.	FA95005	TENSION PIN	1
4.	KE52193-1	THRUST BEARING SPACER	2
5.	KE52192	THRUST WASHER	4
6.	KE52191	ROLLER BEARING	2
7.	FA30088	WASHER	2
8.	FA95008	JAM NUTS	2
9.	KE55057-4	LID FOR GEARBOX	1
10.	FA95062	PAN HD. PHILLIPS SCREW	2
11.	KE00508	HANDWHEEL ASSEMBLY	1
12.	FA19505	HANDWHEEL ALLEN SCREW, HEX SOCKET	1
13.	KE51730	TILT SHAFT BEARING	1
14.	FA19177	HEX SOCKET SET SCREW 5/16-24 X 1"	1
15.	FA20047	JAM NUT 5/16-24	1
16.	KE003209-11	Complete Switch	1
	KE603208-4	Momentary Switch Activator***	1
	KE603208-7	Contact Section Holder, Latch***	1
	KE603208-9	Contact Block***	4
***NOTE: for units built prior to Dec. 2006 order Complete Switch KE003209-11			
19.	KE50580	WATER RESISTANT BOOT	1
20.	FA05002-34	"O" RING, CIRCUIT BREAKER	1
21.	KE50579-1	CIRCUIT BREAKER	1
22.	KE51007	MICRO SWITCH	2
	FA10139	MACHINE SCREW #6-32 X 1" LG	4
	KE50498	MICRO SWITCH INSULATION	2
	FA32004	TOOTH LOCK WASHER #6	4
23.	KE50582	CPLG. ONTARIO BELTING #G-100 5/8 BORE	2
24.	FA95055-6	SQUARE KEY 3/16 X 3/16 X 1" LG	1
25.	KE50583	RUBBER INSERT, ONTARIO BELTING "BUNA N"	1
26.	KE52832-1	MOTOR	1
27.	FA10487	HEX HD SCREW 1/4-20 X 1" LG	4
28.	FA31008	SPLIT LOCKWASHER 1/4" DIA	4
29.	FA20026	HEX NUT 1/4 - 20	4
30.	KE517112	LEFT HAND BEARING	1
31.	KE517111	RIGHT HAND BEARING	1
32.	KE51712	GREASE NIPPLE	2
33.	KE01889	MICRO SWITCH TRIGGER/SEGMENT GEAR WELDMENT	1
34.	FA10772	SOCKET HD. CAP SCREW	2
35.	FA20048	JAM NUT	2
36.	FA95007-4	RETAINING RING	1
37.	FA95055-1	SQUARE KEY	1
38.	FA19201	HEX SOCKET SET SCREW 3/8-24	1
39.	KE50581	BRIDGE RECTIFIER	1
40.	KE54535	EDGE CONNECTOR (11 PIN)	2
41.	KE50753-10	RELAY	2
42.	KE50473	GROUND LUG	1

BUTTERFLY VALVE

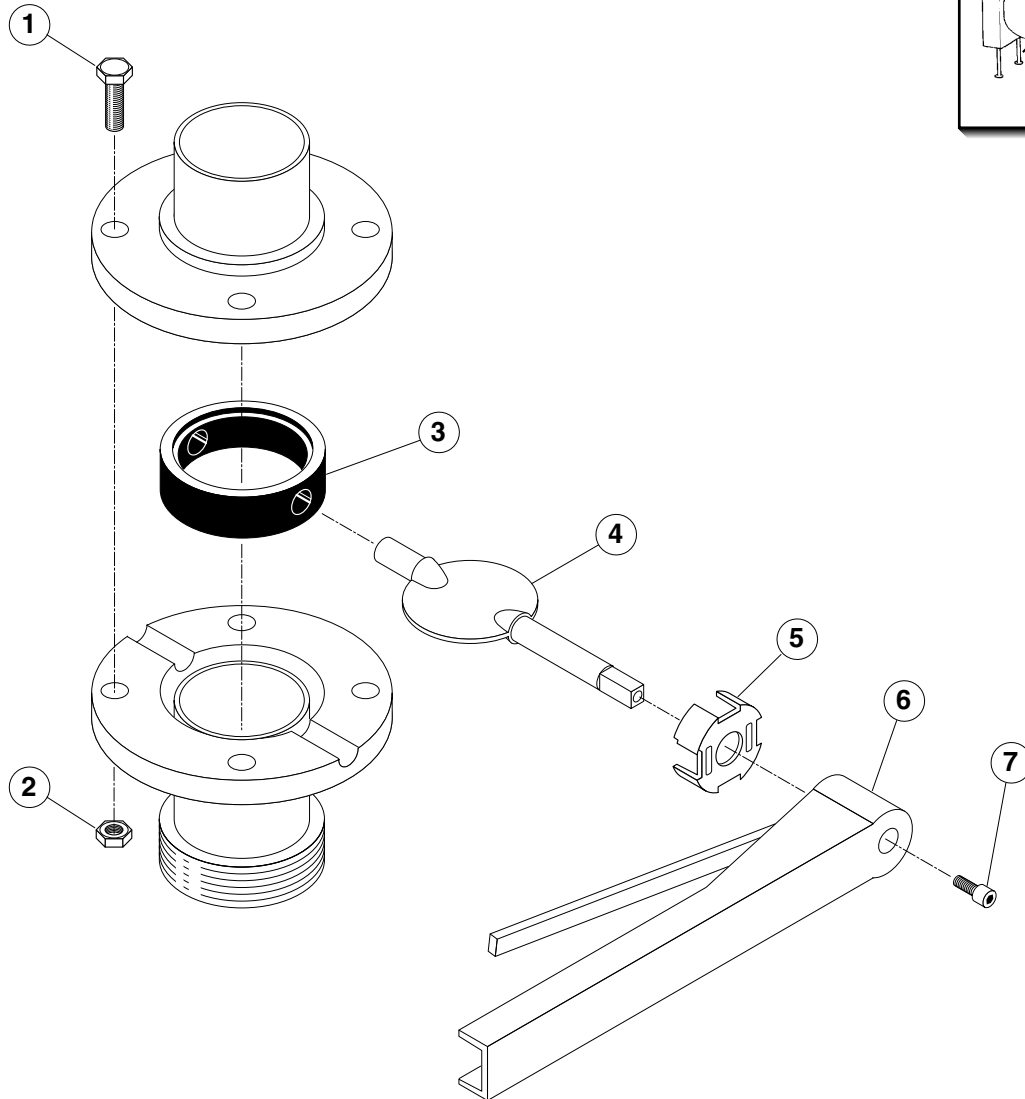
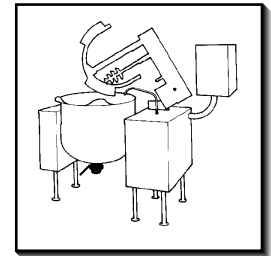

ITEM NO.	PART NO.	DESCRIPTION	QTY.
1. - 7.	KE51603	Butterfly Valve, 2" (includes housing)	1
	KE52286	Butterfly Valve, 3" (includes housing)	1
1.	FA11224	Bolt, 5/16-18x1" S.S.	4
2.	FA21024	Nut, 5/16-18	4
3.	SE50433	Seat, 2"	1
	SE50433-1	Seat, 3"	1
4.	SE50434	Stem, 2"	1
	SE50434-1	Stem, 3"	1
5.	SE50435	Locking Spider, 2"	1
	SE50435-1	Locking Spider, 3"	1
6.	SE50436	Handle Assembly	1
7.	SE50437	Allen Bolt	1

FLUSH PISTON - VALVE (USED PRIOR TO 2003)

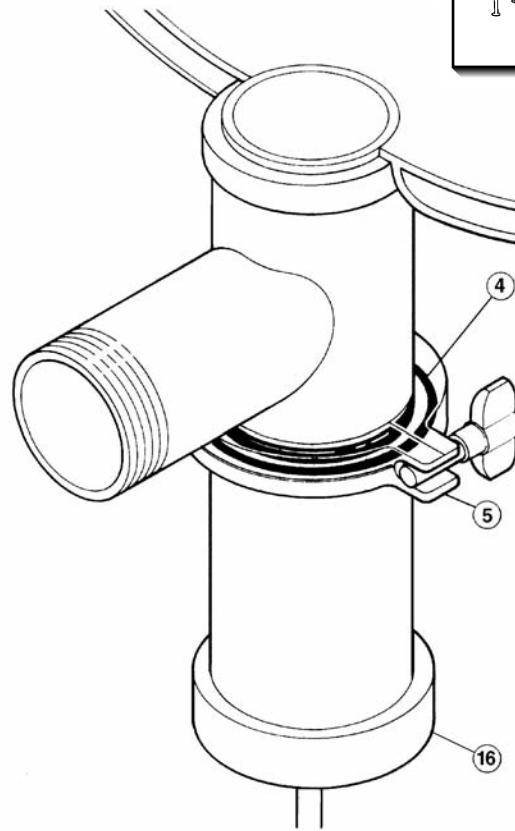
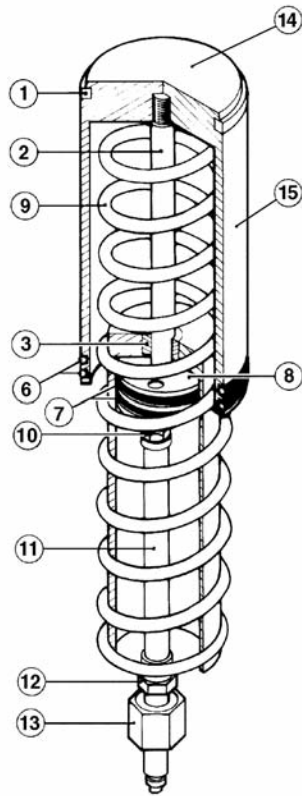
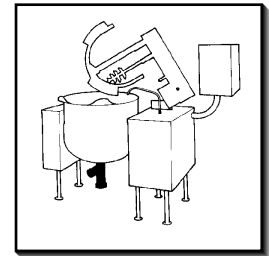

ITEM NO.	PART NO.	DESCRIPTION	QTY.
	T40430	Valve Assembly (includes parts 1 - 16)	1
1.	FA05000	"O" Ring, Cylinder Head	1
2.	KE52345	Piston Shaft	1
3.	KE52346	Air seal	1
4.	KE52347	Sani-Clamp Seal, 4"	1
5.	KE52344	Sani-Clamp, 4"	1
6.	FA05002-22	"O" Ring, Cylinder Body	2
7.	FA05002-21	"O" Ring, Piston	2
8.	KE52315	Piston	1
9.	KE52335	Compression Spring	1
10.-13.	SE00040	Supply Hose Assembly, Piston	1
10.	KE52341	Hose Barb, 1/8" x 1/4"	3
11.	KE52340	Supply Hose, 8"	1
12.	KE52342	Hose Barb, 1/4" x 1/4"	1
13.	KE52338	Quick Connect Male End	1
14.	KE52327	Piston Top	1
15.	KE52328	Piston Cylinder	1
16.	KE52314	Bottom Nut	1

FLUSH PISTON - AIR SYSTEM, 10" CONSOLE

(USED PRIOR TO 2003)

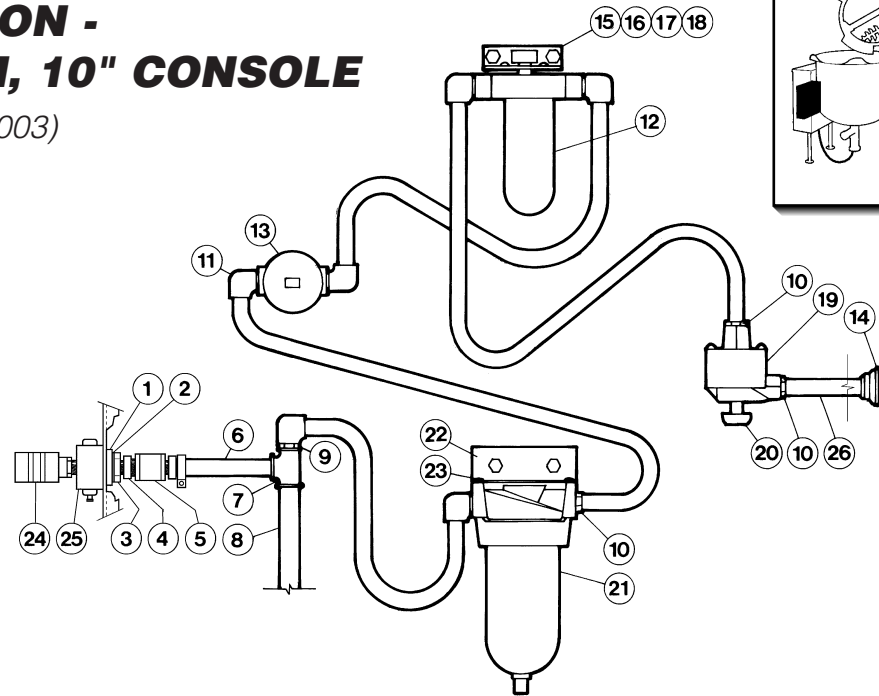

ITEM NO.	PART NO.	DESCRIPTION	QTY.
1.	FA30512	Spacer	1
2.	FA32500	Tooth lockwasher	1
3.	KE52697	Locking nut	1
4.	KE52931	Adapter	1
5.	FI00266	Coupling	1
6.	FI00595-17	Nipple 1/2" NPT	2
7.	FI00178	Tee 1/2" NPT	2
8.	FI00595-12	Nipple 1/2" NPT	1
9.	FI05047	Bushing	1
10.	KE52342	Hose Barb	3
11.	FI05167	Hose Barb 90 Degree Elbow	6
12.	KE52815	Airline Lubricator	1
13.	KE52895	Air Regulator	1
14.	KE52339	Female End Quick Connect	1
15.	KE52932	Bracket For Lubricator	1
16.	FA32006	Toothlock Washer	4
17.	FA21006	Nut	4
18.	FA11091	Machine Screw	2
19.	KE53209	Quick Exhaust Valve	1
20.	KE53210	Muffler	1
21.	KE52031	Air Line Filter c/w Bracket	1
22.	KE53251	Air Line Filter Bracket	1
23.	FA11144	Bindinghead Screw	4
24.	FI05166	Quick connect	1
25.	KE54280	Slide valve	1
26.	KE53215	1/4" Air Hose, 65" Long	1

**FLUSH PISTON -
LUBRICATOR** (USED PRIOR TO 2003)

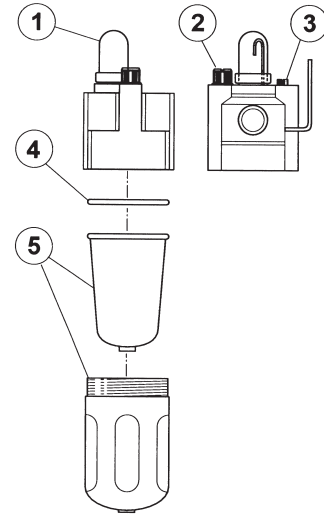

ITEM NO.	PART NO.	DESCRIPTION	QTY.
1.	FA30512	Spacer	1
1.-5	KE52815	Lubricator c/w Bracket	1
1.	SE50418	Sight Dome Assembly	1
2.	SE50419	Filler Cap Assembly	1
3.	SE50420	Needle Valve Assembly	1
4.	SE50422	"O" Ring	1
5.	SE50423	Bowl/Guard Assembly	1

**FLUSH PISTON -
FILTER** (USED PRIOR TO 2003)

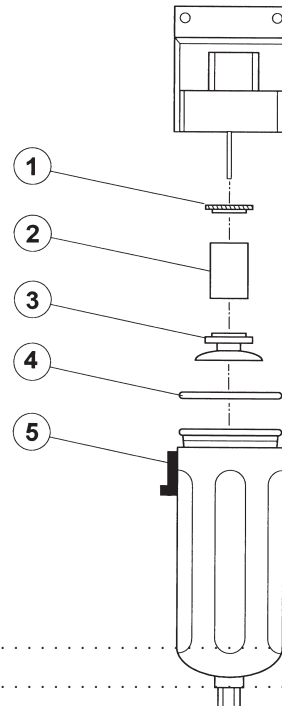

ITEM NO.	PART NO.	DESCRIPTION	QTY.
1.-5	KE52031	Filter c/w Bracket	1
1.	SE50425	Deflector	1
2.	SE50426	Filter Element	1
3.	SE50427	Baffle	1
4.	SE50428	"O" Ring	1
5.	SE50429	Bowl/Guard Assembly	1

FLUSH PISTON - VALVE (USED AFTER TO 2003)

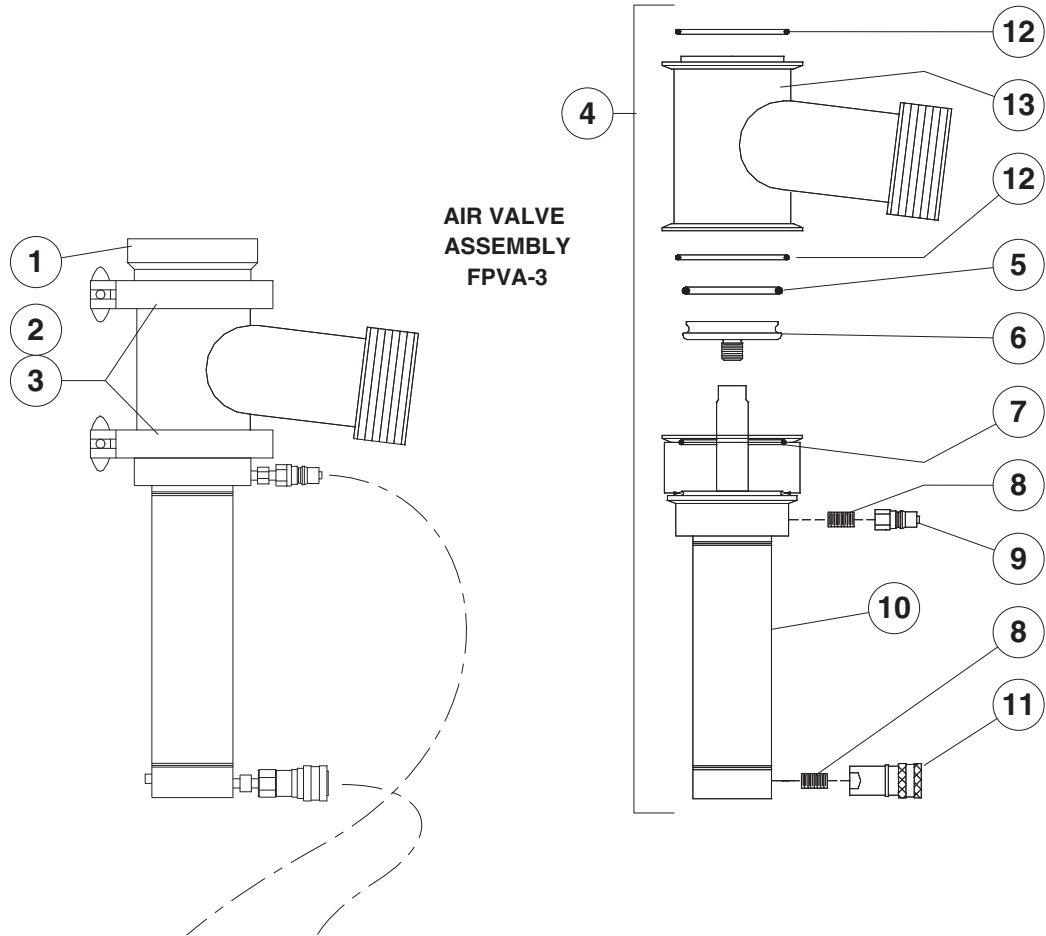

ITEM ON.	PART NO.	DESCRIPTION	QTY.
1.	KE55210	WELD RING, KETTLE BOTTOM OUTLET	1
2.	FI05144-3	SANI CLAMP, 3"	2
3.	KE52154-4	GASKET, SANI CLAMP, 3"	2
4.	KE02291	COMPLETE ACTUATOR AND DISCHARGE VALVE ASSEMBLY <i>INCLUDES PARTS 5. - 13.</i>	1
5.	KE55248	BUNA-N O-RING	1
6.	KE55249	REPLACEABLE S.S. PLUNGER HEAD	1
7.	KE55250	BUNA-N O-RING	1
8.	KE55251	1/8 NPT S.S. HYDRAULIC CLOSE NIPPLE	2
9.	KE55252	MALE S.S. QUICK DISCONNECT	1
10.	KE55253	AIR OPERATED CYLINDER	1
11.	KE55254	FEMALE S.S. QUICK DISCONNECT	1
12.	KE55255	BUNA-N O-RING	2
13.	KE55256	BODY, DISCHARGE VALVE	1

FLUSH PISTON - AIR SYSTEM, 10" CONSOLE

(USED AFTER TO 2003)

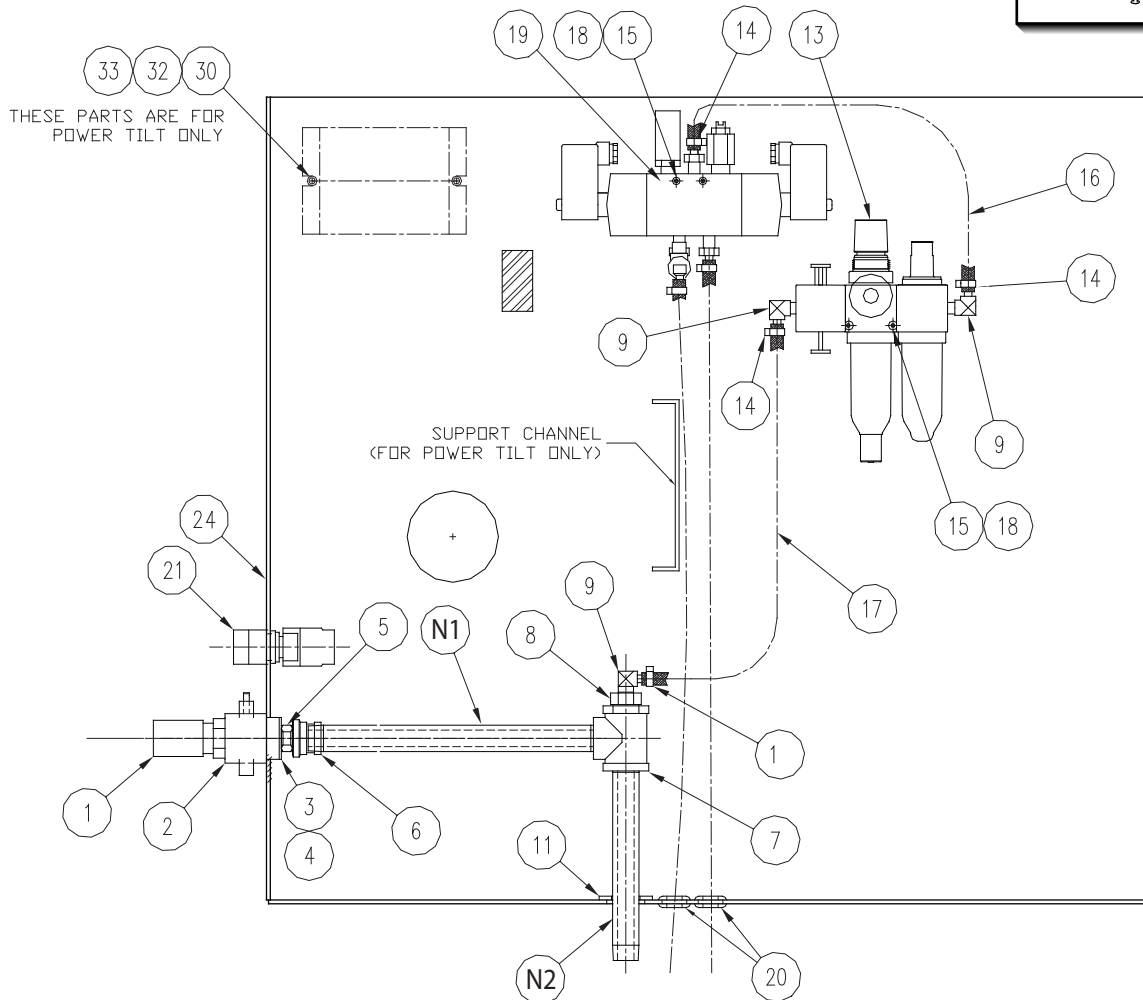
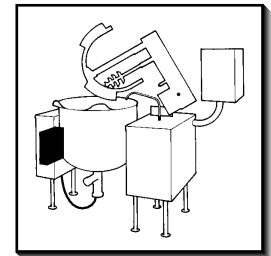

ITEM NO.	PART NO.	DESCRIPTION	QTY.
1	KE601603	QUICK CONNECT	1
2	KE601601	SLIDE VALVE	1
3	FA30512	SPACER WASHER	1
4	FA32500	TOOTH LOCK WASHER 7/8 DIA,	1
5	KE52697	NUT 1/2 NIPS BRASS	~
6	KE601602	AIR FITTING	1
7	KE600814-1	TEE 1/2 NPT (FIP x FIP x FIP)	1
8	FI00351	BUSHING 1/2 MIP x 1/4 FIP	1
9	FI05318	HOSE BARB 90° ELBOW	3
11	FA30090	WASHER 15/16 IDx1 3/4 ODX1/8 THK	1
13	KE02369	FILTER-REGULATOR ASSEMBLY	1
14	FI05220-1	GEAR CLAMP	4
15	FA21002	#6-32 HEX NUT SS	4
16	KE532176	PNEUMATIC HOSE (1/4 I.D.x12 1/2 LG.)	1

FLUSH PISTON - AIR SYSTEM, 10" CONSOLE

(USED AFTER TO 2003)

17	KE532177	PNEUMATIC HOSE, (1/4 I.D.x 31 LG.)	1
18	FA32004	TOOTH LOCK WASHER, #6 ZINC PLATED	4
19	SEE FOLLOWING PAGE: FLUSH PISTON - AIR SOLENOID VALVE (Used after to 2003)		
20	KE50555-3	GROMMET	2
21	KE01812-1	SWITCH ON/OFF/ON (MAINT/MAINT/MOM)	1
24	KE95481-5	LABEL, PRODUCT DISCHARGE VALVE	1
25	KE55232	WIRING DIAGRAM FOR AIR VALVE (NOT SHOWN)	1

POWER TILT OPTION

30	KE02185	COMPONENT PLATE	1
32	FA21007	#10-32 HEX NUT SS	2
33	FA40000-6	TOOTH LOCK WASHER, #10 ZINC PLATED	2

NIPPLES

for MKDL-40CC

N1	FI00595-17	NIPPLE, 1/2 NPT x 11 1/8 LG. BRASS	1
N2	FI0059 5-12	NIPPLE, 1/2 NPT x 10 1/2LG. BRASS	1

for MKDL-60CC

N1	FI00595-17	NIPPLE, 1/2 NPT x 11 1/8 LG. BRASS	1
N2	FI00595-13	NIPPLE, 1/2 NPT x B 7/8 LG. BRASS	1

for MKDL-80CC

N1	FI00595-17	NIPPLE, 1/2 NPT x 11 1/8 LG. BRASS	1
N2	FI00595-14	NIPPLE, 1/2 NPT x 8 1/2 LG. BRASS	1

for MKDL-100CC

N1	FI00595-12	NIPPLE, 1/2 NPT x 10 1/2 LG. BRASS	1
N2	FI00595-15	NIPPLE, 1/2 NPT x 6 7/8 LG. BRASS	1

for MKDL-125CC

N1	FI00595-19	NIPPLE, 1/2 NPT x 13 7/8 LG. BRASS	1
N2	FI00595-16	NIPPLE, 1/2 NPT x 7 5/8 LG. BRASS	1

for MKDL-150CC

N1	FI00595-12	NIPPLE, 1/2 NPT x 10 1/2 LG. BRASS	1
N2	FI00595-7	NIPPLE, 1/2 NPT x 4 LG. BRASS	1

for MKDL-200CC

N1	FI00595-19	NIPPLE, 1/2 NPT x 13 7/8 LG. BRASS	1
N2	FI00595-11	NIPPLE, 1/2 NPT x 6 LG. BRASS	1

for MKDL-250CC

N1	FI00595-19	NIPPLE, 1/2 NPT x 13 7/8 LG. BRASS	1
N2	FI00595-7	NIPPLE, 1/2 NPT x 4 LG. BRASS	1

FLUSH PISTON - AIR SOLENOID VALVE

(USED AFTER TO 2003)

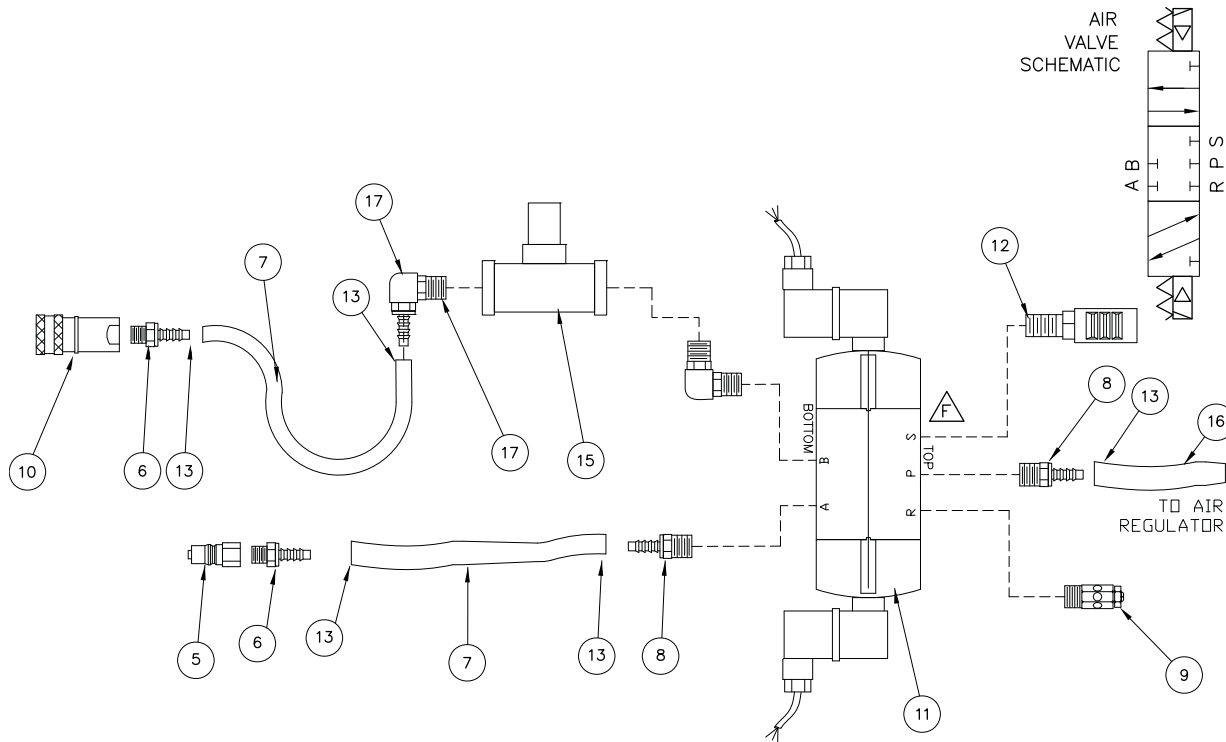

ITEM ON.	PART NO.	DESCRIPTION	QTY.
5.	KE55257	MALE QUICK PLUG	1
6.	FI05317-1	HOSE BARB, 1/8" NPT MALE TO 1/4" HOSE	2
7.	KE55259-1	1/4" ID X 6 FT LONG HOSE, 250 #W,P.	2
8.	FI05317-2	HOSE BARB, 1/4" NPT MALE TO 1/4" HOSE	2
9.	KE55261-1	EXHAUST MUFFLER, 1/8"	1
10.	KE55262	FEMALE QUICK PLUG	1
11.	KE55263-1	5 WAY AIR SOLENOID VALVE	1
12.	KE55264-1	STANDARD 1/8" MUFFLER	1
13.	FI05220-1	GEAR CLAMP FOR 1/4" I,D, HOSE (NOT SHOWN)	5
14.	FI05030-2	90° 1/4" ELBOW, MALE PIPE THREAD	1
15.	KE55305	1/4" FLOW CONTROL	1
16.	KE55259-2	1/4" ID X 3 FT LONG HOSE, 250 #W,P.	1
17.	FI05318	90° ELBOW HOSE BARB/ 1/4" HOSE I,D./14" PIPE, BRASS	1

WATER METER ASSEMBLY - 18" CONSOLE

ITEM NO.	PART NO.	DESCRIPTION	QTY.
1.	FI05058	3/4" Cross	1
2.	KE02055-2	Steam Valve Modification	2
3.	N0640B4.5	Nipple	2
4.	FI00063	Elbow 90 degree	4
5.	FI000356	Reducing Bushing	1
6.	KE600812-1	Street Elbow	1
7.	FI05029	Hose Barb	2
8.	KE54834-5	* Solenoid Valve, 3/4"	1
	SE50407	Rebuild Kit	
	SE50401	Replacement Coil	
9.	N0640B3	Nipple, Gallon Meter	1
	N0640B3.5	Nipple, Litre Meter	
10.	FI00363-3	Reducing Elbow 90 Degree	1
11.	KE51861	Gallon Meter	1
	KE51860	Litre Meter	
12.	FI00062	Elbow 90 Degree	1
13.	KE52173	1/2"1.D. Hot Water Wash-up Hose	1
14.	FI05220-3	Hose Clamp	2
15.	FI00179	Tee	1
16.	FI05074	Adapter, Gallon Meter	2
	KE600362	Adapter, Litre Meter	
17.	N0640B1.5	Nipple	1
18.	FA11091	Machine Screw	8
20.	KE51369	Steam Valve Flange	2
21.	SE00028	Knob Assembly	2
22.	KE95321	Label "Hot"	1
23.	KE95322	Label "Cold"	1
24.	SD50097	Flanged Nut	1
25.	KE51585	Faucet Spout Fitting	1
26.	KE50825-12	Faucet Spout	1
27.	FA05002-19	"O" Ring	1
28.	FA95022	Retaining Ring Carter	1
29.	KE51736	Long Faucet Nut	1

***NOTE:** See SOLENOID VALVE MAINTENANCE section for further information.

ELECTRICAL COMPONENT BOX

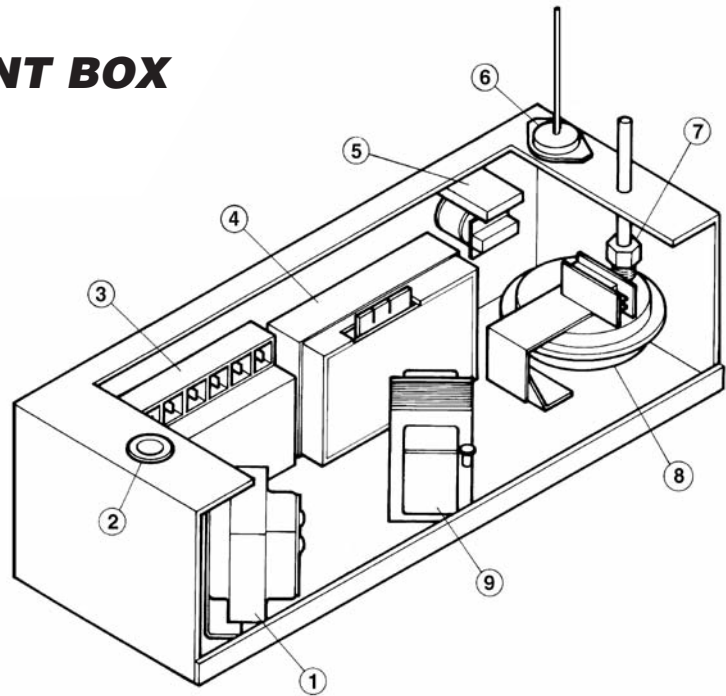

ITEM ON.	PART NO.	DESCRIPTION	QTY.
	KE01422	ELECTRICAL CONTROL BOX ASSEMBLY	1
	KE53439	COMPONENT BOX	1
	KE53440	COVER, COMPONENT BOX	1
	KE53599-1	GASKET	1
1.	KE53838-27	TRANSFORMER, 120-14V.	1
	KE53444	TRANSFORMER BRACKET	1
2.	KE54833-3	SNAP-IN BUSHING, 0.875" DIA.	1
3.	KE02372	IGNITION MODULE, PRIOR TO SEPT. 2004	1
	KE53469-4	IGNITION MODULE, SEPT. 2004 AND AFTER	1
4.	KE00458	KETTLE SOLID STATE CONTROL BOX	1
	KE50303	BRACKET, SOLID STATE CONTROL BOX	1
5.	KE50753-7	RELAY, 120V	1
	KE50753-8	RELAY, 240V	1
6.	KE55069-8	SAFETY THERMOSTAT	1
7.	FI05050	BRASS NUT, 7/16-24	1
8.	KE02400	AIR SWITCH, PRIOR TO SEPT. 2004	1
	KE55453-1	AIR SWITCH, SEPT. 2004 AND AFTER	1
9.	KE53838-20	TRANSFORMER 120-24V	1

SIGHT GLASS

ITEM ON.	PART NO.	DESCRIPTION	QTY.
1.	KE50955	RETAINING COVER	1
2.	KE52871	GASKET	1
3.	KE51053-1	SIGHT GLASS	1
4.	FA05002-30	"O" RING	1

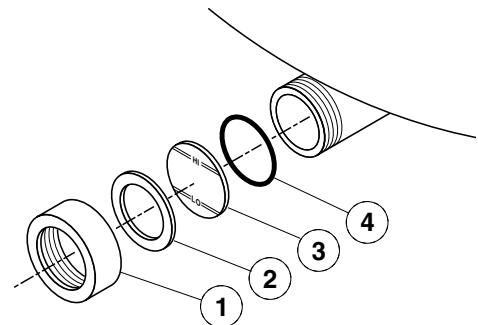

CONSOLE CONTROLS

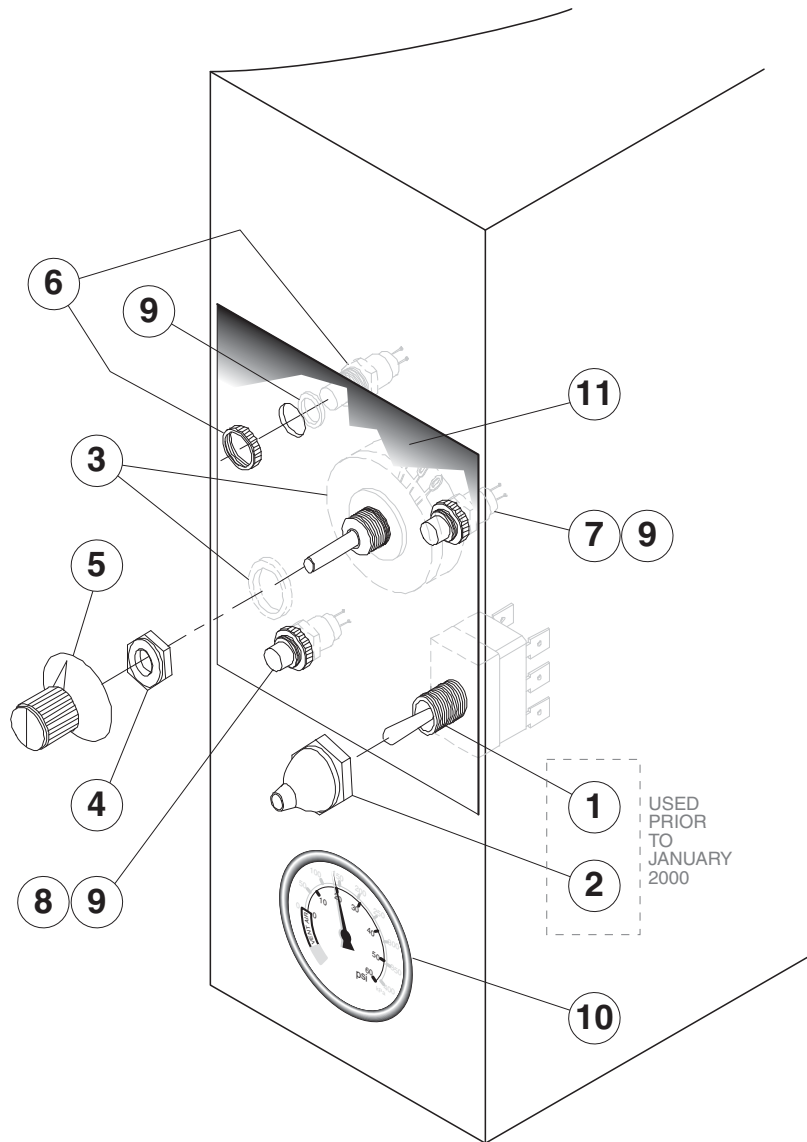

ITEM NO.	PART NO.	DESCRIPTION	QTY.
1.	KE50504	SWITCH, TOGGLE (USED PRIOR TO JANUARY 2000)	1
2.	SK50062	RUBBER BOOT (USED PRIOR TO JANUARY 2000)	1
3.	SE00114	POTENTIOMETER WITH ON/OFF SWITCH, C/W ITEM #4	1
	KE50988-2	POTENTIOMETER (USED PRIOR TO JANUARY 2000)	1
4.	KE51005	RUBBER BOOT	1
5.	KE50569-1	KNOB, POTENTIOMETER	1
6.	KE50567-1	L.E.D., RED	1
7.	KE50568-1	L.E.D., GREEN	1
8.	KE50567-2	L.E.D., AMBER (USED PRIOR TO JULY 2004)	1
9.	FA05002-18	"O" RING	3
10.	KE50429-2	PRESSURE GAUGE	1
11.	KE5555-5-B	LABEL	1
	KE95457	LABEL (USED PRIOR TO JANUARY 2000)	1

MAIN CONSOLE CONTROLS

NOTE: See SWITCH CONFIGURATIONS for applicable contact cartridge/capacitor combinations and part numbers

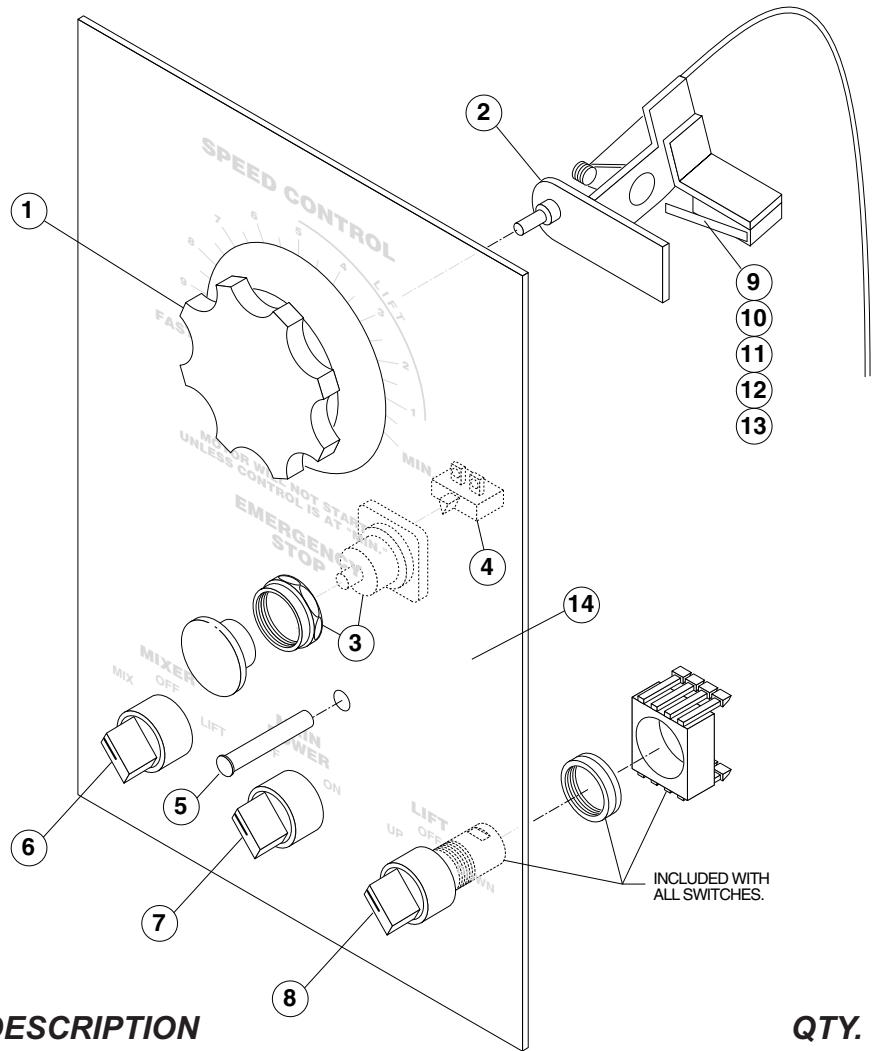

ITEM NO.	PART NO.	DESCRIPTION	QTY.
1.	KE52190	Knob, Speed Control	1
2.	KE00860	Cable and Bracket, Speed Control (includes items 9 - 13)	1
3.	KE53193	Emergency Switch	1
4.	KE53377	Push Button Contact Block	1
5.	SK50315-1	Pilot Light	1
6.	KE003209-5	Switch Assembly, On/Off/On - Maintained	1
7.	KE003209-1	Switch Assembly, On/Off - Maintained	1
8.	KE003209-8	Switch Assembly, On/Off/On - Momentary	1
9.	KE52180	Micro Switch	1
10.	FA10032	Machine Screw, #4-40 x 5/8" LG	2
12.	FA32002	Tooth Lock Washer #4	2
13.	FA20000	Hex Nut, #4-40	2
14.	KE95230-E	Label:	1

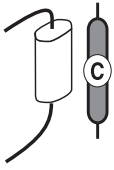
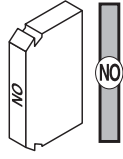
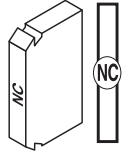

SWITCH CONFIGURATION

INDEX		
Capacitor	Contactor Cartridges *	
 <p>C</p>	 <p>NO (normally open - green)</p>	 <p>NC (normally closed - red)</p>
PART NO.		
KE52074	KE603208-9	KE603208-8

NOTES: *For units built prior to December 2006, the complete switch assembly must be ordered (see applicable drawing).

Refer to Maintenance Section for Switch Disassembly Instructions.

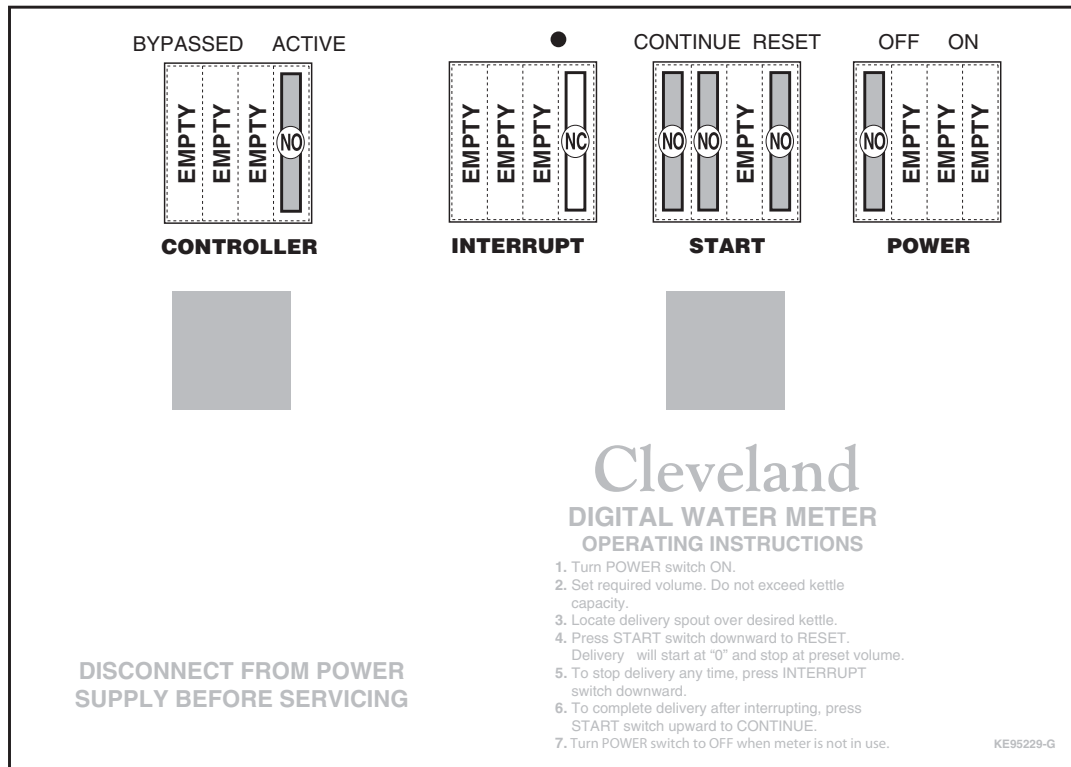
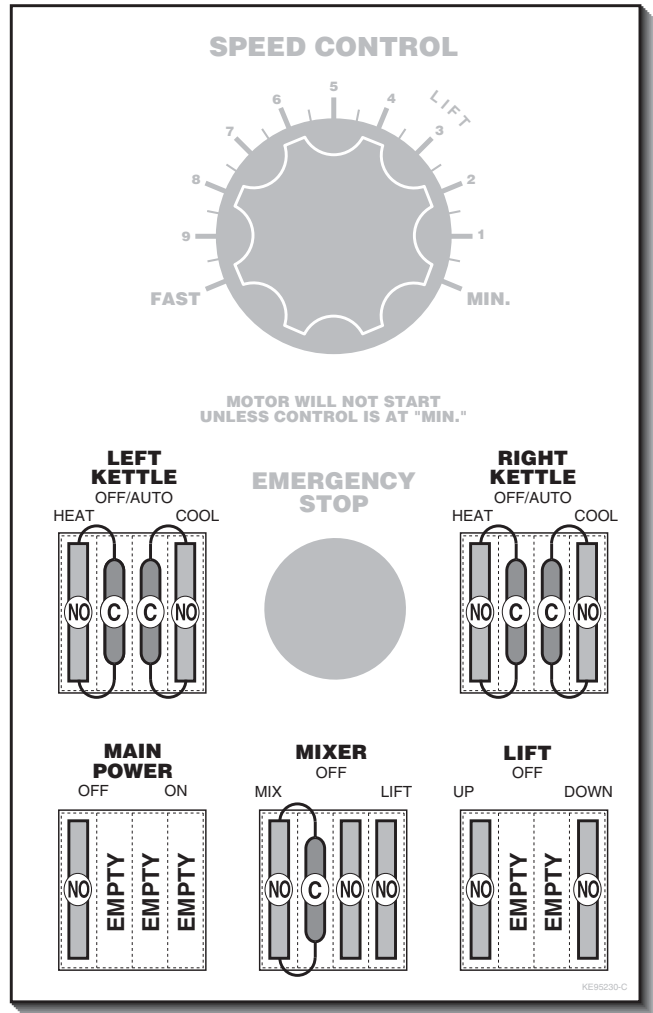

ELECTRICAL COMPONENT ASSEMBLY

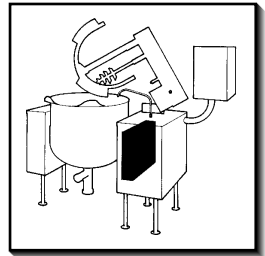
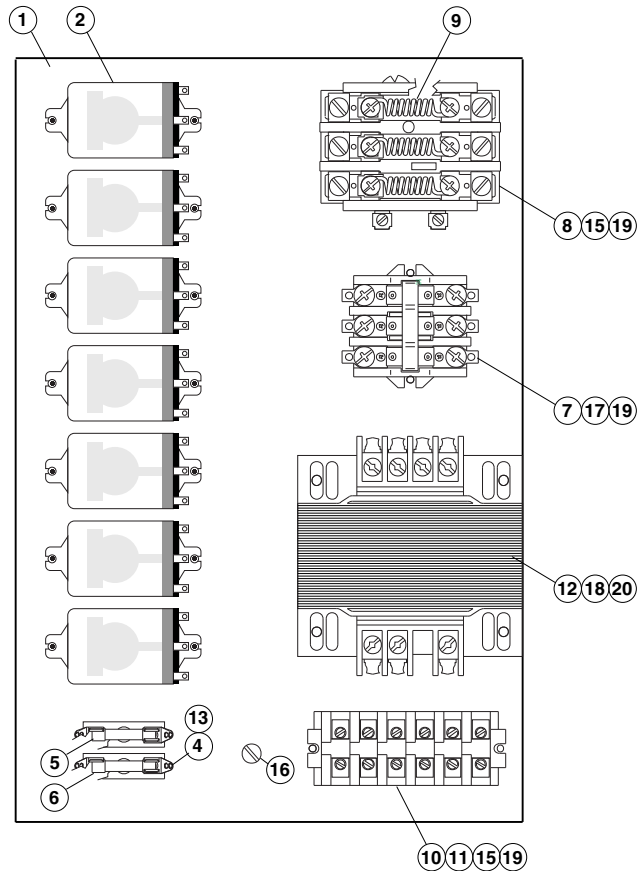
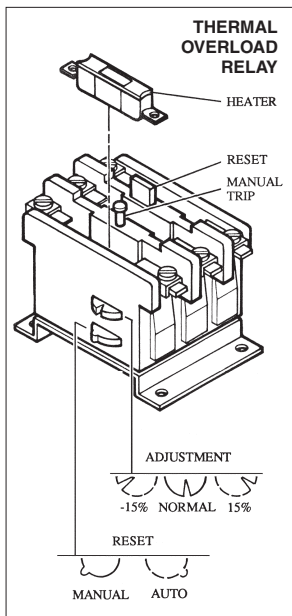

ITEM NO.	PART NO.	DESCRIPTION	QTY.
1.	KE50343-7	Component Mounting Plate	1
2.	KE50753-10	Relays	2-7
4.	KE51139	Fuse Holder	2
5.	SK50445	Fuse (3 amps)	1
6.	KE52936	Fuse (1 amps)	1
7.	KE50750-1	Contactor	1
8.	KE51982	Thermal Overload Relay	1
9.		Heater for Thermal Overload	3
	KE52055	200, 208, 220, 240, 380 & 415 volt	
	KE52051	440, 480 volt	
10.	SK50055-1	Terminal Block Sections	3-6
11.	SK50054-1	Terminal Block End Section	1
12.		Transformer	1
	KE53838-2	200, 208, 220, 240, 440 & 480 volt	
	KE53838-6	380 & 415 volt	
13.	FA10133	Screws #6-32x3/8" lg.	3
15.	FA10239	Screws #8-32x3/8" lg.	6
16.	FA12500	Screws #8-32x3/8" lg. (brass with undercut)	1
17.	FA10245	Screws #8-32x1" lg.	2
18.	FA10362	Screws #10-32x3/8" lg.	4
19.	FA32005	Lockwashers #8	8
20.	FA32006	Lockwashers #10	4

MAINTENANCE

INSPECTION AND MAINTENANCE CHECK LIST

Cleveland Range equipment requires little preventative maintenance. We do however provide the following chart as a guide line for inspection and maintenance to keep your unit functioning at 100%.

Item Inspection

MONTHLY INSPECTIONS

Switches	Inspect switches for damage and correct operation. Replace as required.
<u>Product Drain Valves</u>	
Butterfly Valve	Inspect parts for damage. Test valve for leakage. Replace as required.
Air Valve	Inspect parts for damage. Test valve for leakage. Check valve seals for air leakage. Inspect supply hose and fittings. Replace as required. Inspect air filter and replace if required.

SIX MONTH MAINTENANCE

Lubrication	Grease trunnion housings and gear/worm assembly as recommended in Lubrication Instructions. Grease bridge swivel assembly. Use "Never Seize" on tilt worm and gear.
Kettle Console Cover	Inspect gasket material for integrity. Replace if necessary. Insure all screws are in place and firmly holding down the cover. If not replace/tighten screws.
Hand wheel (hand tilt models only)	Check hand wheel for tightness. If loose tighten allen screw.
Tilting (tilting models only)	Check that kettle tilts smoothly. Grease as described in Lubrication Procedure.
On-Off Switch/Temperature Control	Check for damage. Replace if necessary.
Pressure Gauge	Check that the gauge does not have moisture on its inside face. Replace if moisture is present. Check that the gauge shows a vacuum (needle is well into the Green zone) when cold and shows between 25-40 psi when unit is hot. If not follow Vacuum Leak Test Procedure.
Pressure Relief Valve	Check pressure relief valve as described in Pressure Relief Valve Testing Procedure .
Temperature Check	Following Calibrating Procedure check the inner kettle surface temperature with a digital surface thermometer. Adjust if required.
Gear/Worm Assembly	Inspect for play. Tighten Allen screws if required.

YEARLY MAINTENANCE

Lubrication	Drain hydraulic oil and remove filter. Replace oil and filter (see Hydraulic Oil Replacement Procedure).
Solenoid Valves	Inspect solenoid valves for proper operation. Clean or replace as required.

KETTLE SAFETY INSPECTION CHECKLIST

Regular inspection and maintenance of units is essential to obtain trouble free and safe operation of equipment. Inspections must include testing of the pressure relief valve and checks of the operating system to insure that it has not been altered.

No safety features designed into the equipment should ever be tampered with. Tampering with or bypassing controls is a very dangerous practice and unfortunately we have seen several cases of this. Following is a short list of the most common and the most dangerous alterations performed on kettles.

SAFETY VALVE:

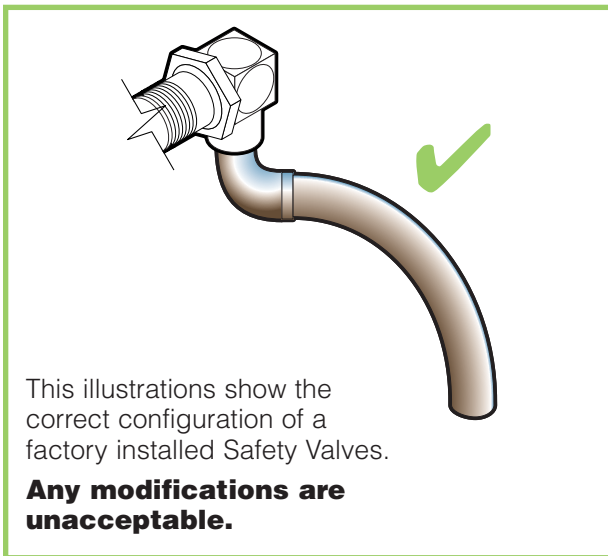

Incorrect Installations

- 1** Safety valve has plug threaded into the discharge opening preventing any steam from escaping.
- 2** Safety valve's tube diameter has been reduced.
- 3** Safety valve is sticking, frozen shut or plugged. To test PRESSURE RELIEF VALVE PERIODIC TESTING.
- 4** Safety valve is plumbed to a drain or water line creating back pressure and reducing flow.

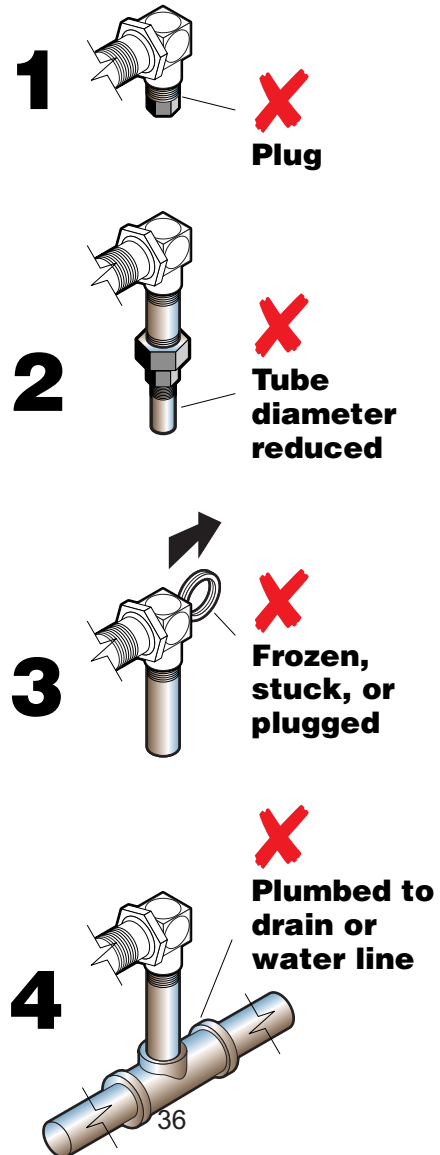

SAFETY THERMOSTAT:

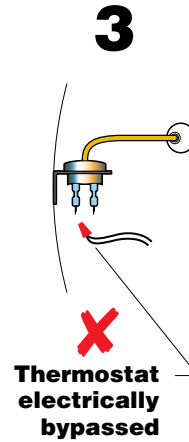
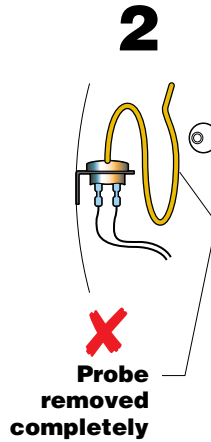
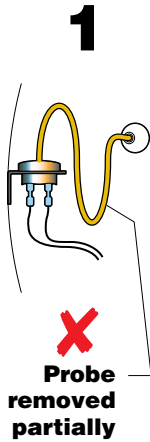
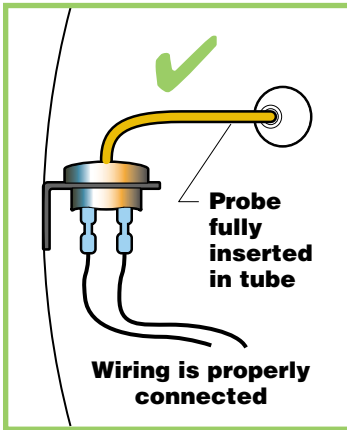

Incorrect Installations

- 1** Safety thermostat probe is not completely inserted into tubing.
- 2** Safety thermostat probe is removed from tubing.
- 3** Safety thermostat electrical connection is bypassed.

Low Water Level Probe:

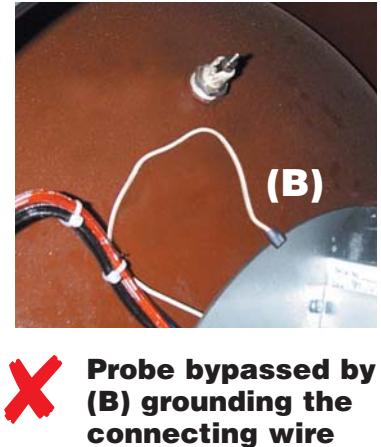
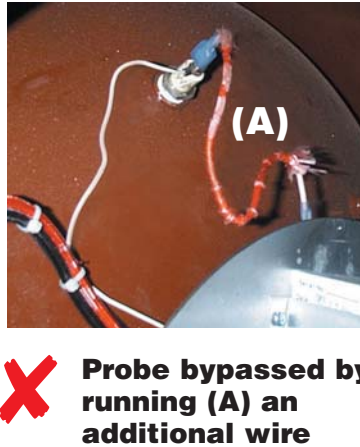

Operating Thermostat:

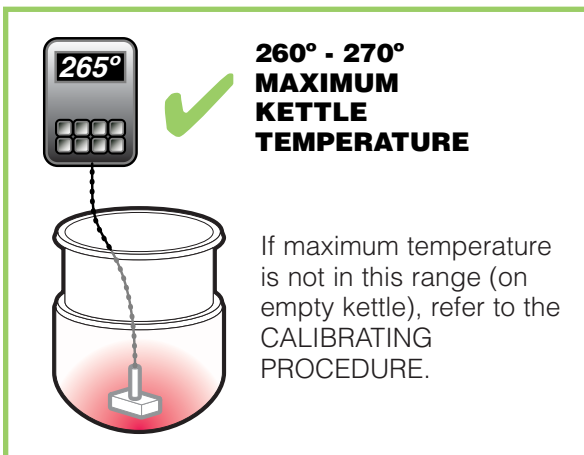

Air Switch:

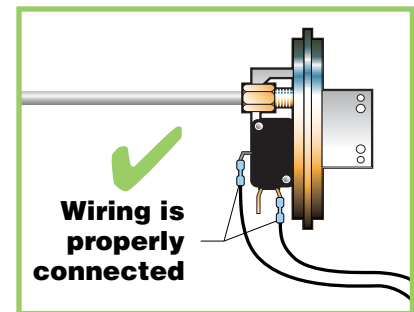

Incorrect Installation

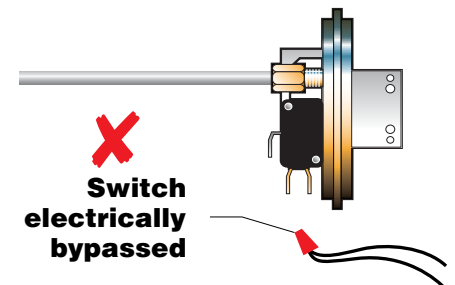

LUBRICATION PROCEDURE

Lubricate the following parts every three months to insure smooth operation and reduce wear.

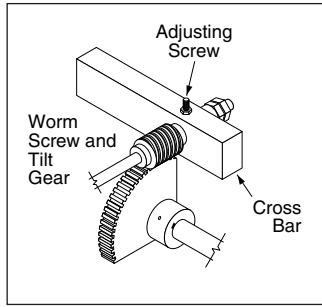

TRUNNION HOUSING, WORM SCREW AND TILT GEAR

These parts are accessed through the top cover of the console.

Apply grease to gear teeth. Check for

excessive play and adjust with adjusting screw located on top of cross bar.

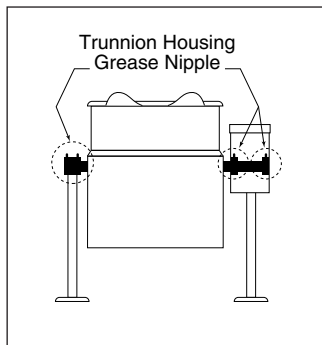

KETTLE TRUNNIONS

On the left hand side of the kettle there are two grease nipples on the top back portion of the trunnion housing. On the right hand side of the kettle you must remove the console cover to access the two grease nipples.

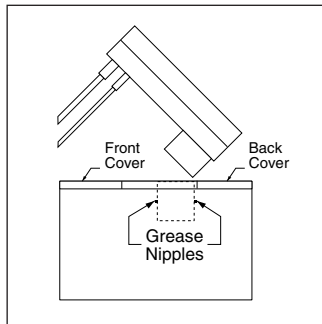

MIXER BRIDGE HOUSING

There are two grease nipples on the mixer bridge swivel housing which are accessed by removing the front and back covers on the 18" console.

Side View of 18" Console

RE-INSTALLING SPEED CONTROL CABLE

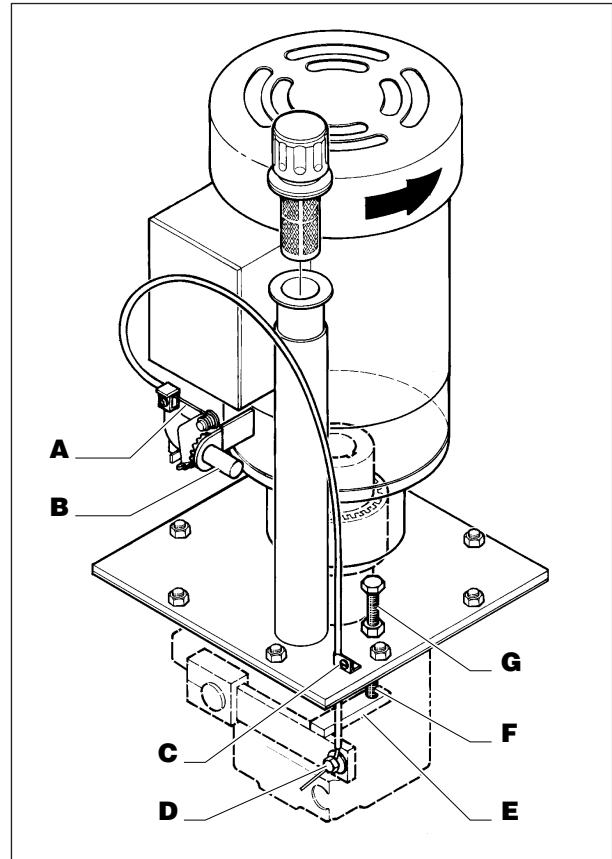

Speed Control Assembly

1. Turn sprocket of speed control so that wire "A" is fully extended towards shaft "B".
2. Insert end of cable through bracket "C".
3. Insert wire so it protrudes approximately 1/2" to 5/8" through hole in bolt "D". Tighten bolt and bend end of wire.
4. Bring pump arm "E" up until it hits stop bolt "F" and tighten screw "C".
5. Reassemble unit. Speed control knob will go on pointing toward minimum setting.
6. Turn mixer on with speed control set at minimum setting.
7. If scraper arm is turning, loosen nut "G" and back stop bolt "F" off a few turns. Next loosen screw "C" and slowly pull up cable until scraper arm stops turning. Retighten screw "C". Gently turn stop bolt "F" down until it hits arm. Lock in place by tightening nut "G".
8. Scraper arm should now go from no rotation to fast rotation by turning speed control knob.

NOTE: Mixer may run rough and noisy for one or two hours if air has become trapped in the line.

HYDRAULIC OIL REPLACEMENT PROCEDURE

One of the most important maintenance tasks is to change the hydraulic oil yearly. Under heavy usage the oil should be changed every nine months. It is important to change the oil regularly to prevent its breakdown which leads to the damaging of components.

The oil filter should be changed at the same time as the hydraulic oil. A clean filter prevents particles from damaging the other components in the system.

Replace the hydraulic fluid as follows:

- ⇒ Disconnect power to unit.
- ⇒ Remove the front top panel on the main console.
- ⇒ Remove chrome vent cap from breather pipe located beside electric motor.
- ⇒ Remove plug bolt from bottom left front corner of main console to drain oil into your catch pail.
- ⇒ Remove oil filter.
- ⇒ Replace plug bolt.
- ⇒ Refill unit through breather pipe using approximately 12 U.S. gallons of Tellus 32 hydraulic oil (oil should be 6 1/2" deep in tank).
- ⇒ Install new oil filter (Part# SE50094).
- ⇒ Replace chrome vent cap and front top panel.
- ⇒ Reconnect power to unit.
- ⇒ Run unit to remove any air in the lines.

NOTE: Mixer may run rough and noisy for one or two hours if air has become trapped in the line.

AIR LINE LUBRICATOR OIL FILLING PROCEDURE

1. Disconnect air supply and bleed system.
2. Remove cover on console
3. Check for oiler location.

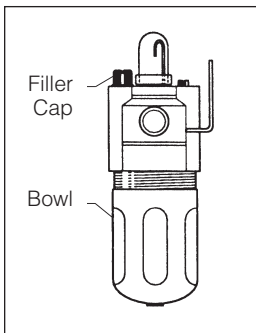

4. Inspect oil level in bowl.
5. Remove filler cap.
6. Add mineral oil as required.
7. Replace filler cap and console cover.

Oiler

AIR FILTER REPLACEMENT PROCEDURE

1. Disconnect air supply and bleed system.
2. Remove cover on console.
3. Check for filter location.

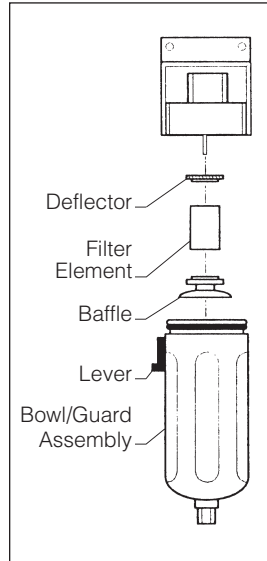

Air Filter

4. Push lever down and rotate bowl/guard assembly 1/8 turn.
5. Push down on bowl/guard assembly and remove.
6. Unscrew baffle and remove filter element, inspect and replace filter if required.
7. Replace filler cap and cover.

DISASSEMBLY OF SWITCH ASSEMBLY

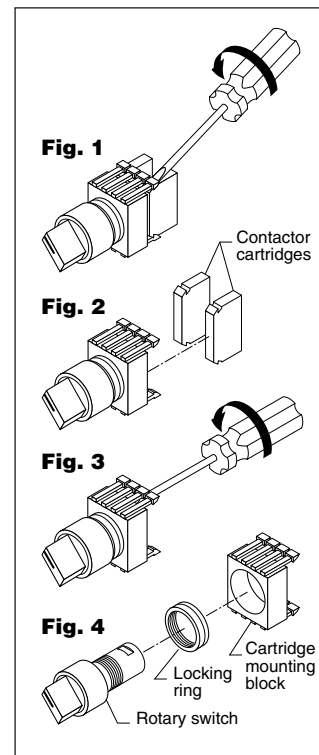

Switch Assembly

1. Place slotted screwdriver between contactor cartridge and cartridge mounting block as shown in **Fig. 1**.
2. Twist screwdriver to free cartridge.
3. Place screwdriver under tab in the back of the cartridge mounting block as shown in **Fig. 3**.
4. Twist screwdriver to remove block from the rotary switch.
3. Unscrew locking ring to remove rotary switch.

KETTLE VENTING INSTRUCTIONS

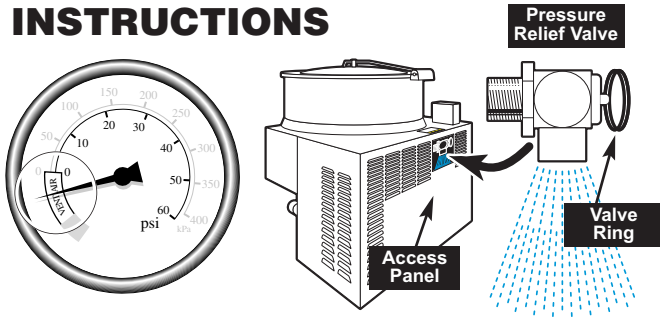

The following venting procedure should be followed when the Vacuum/Pressure Gauge needle is in the "VENT AIR" zone:

NOTE: Check for and eliminate leaks prior to venting (See REPAIRING LEAKS IN STEAM JACKETED KETTLE FITTINGS).

DANGER: PRESSURE RELIEF VALVE WILL EXHAUST HIGH TEMPERATURE STEAM. CONTACT WITH SKIN COULD RESULT IN SERIOUS BURNS. KEEP FACE, HANDS AND BODY CLEAR OF DISCHARGE.

DANGER: WORKING ON MACHINES WITH POWER COULD RESULT IN SEVERE ELECTRICAL SHOCK.

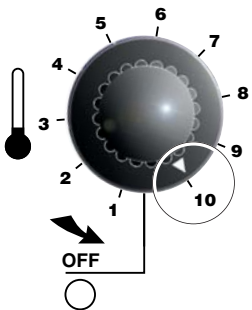

1. Remove Access Panel from back of main kettle console.
2. Turn kettle ON and set temperature control to **10**, heat the empty kettle until unit cycles off.
3. Vent kettle by pulling Valve Ring eight to fifteen times, holding valve open for two seconds each time.

NOTE: If unit cycles ON, stop venting and wait for kettle to cycle OFF before continuing.

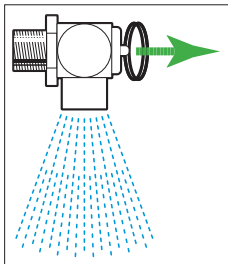

4. Turn kettle OFF. Add cold water to kettle until its surface temperature is below 100°F. The pressure gauge needle should be in the green zone, indicating a vacuum in the kettle's jacket.

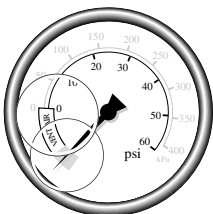

5. If needle is in the green zone then venting was successful. If not repeat procedure.

VACUUM LEAK TEST PROCEDURE

If the kettle will not hold vacuum, test for leaks at:

- A. Water Level Probe.
- B. Pressure Relief Valve/Pressure Gauge and connecting plumbing.
- C. Boiler Drain Cap.
- D. Sight Glass.

LEAK TEST PROCEDURE:

1. Heat kettle until unit cycles off.
2. Shut off power to the kettle at the fused disconnect switch.
3. Spread Bubble Type Leak Detector over suspected areas and watch closely for bubbles.
4. Repair areas as required.

REPAIRING LEAKS IN STEAM JACKETED KETTLE FITTINGS

If unit will not hold a vacuum the most likely cause is a leak at one of the fittings.

Often, the easiest way to eliminate a leak is reseal the suspect areas.

1. Water Level Probe
Remove, clean threads, apply teflon thread sealant and reinstall.
2. Pressure Relief Valve
A/ Inspect for signs of leaks. Replace if required.
B/ Remove, clean threads, apply teflon thread sealant and reinstall.
3. Pressure Gauge
A/ Inspect face of gauge. If it contains moisture on the inside of face replace.
B/ Check tightness of plumbing connection to pressure Gauge.
3. Sight Glass
A/ Check tightness of sight glass.
B/ Replace "O" ring if required.

RESERVOIR FILL PROCEDURES

WARNING: IMPROPER REFILLING OF KETTLE JACKET WILL RESULT IN IRREVERSIBLE DAMAGE TO UNIT.

The kettle's water level must be maintained at the proper level. Under normal operating conditions, the sealed water reservoir should never require the addition of water.

If the red "low water" light comes on during use (while the kettle is in an upright position), the water level has reached a critically low level. The low water protection control has automatically shut off the gas burner. The following procedure must be completed before further use:

DANGER: PRESSURE RELIEF VALVE WILL EXHAUST HIGH TEMPERATURE STEAM. CONTACT WITH SKIN COULD RESULT IN SERIOUS BURNS. KEEP FACE, HANDS AND BODY CLEAR OF DISCHARGE.

DANGER: WORKING ON MACHINES WITH POWER COULD RESULT IN SEVERE ELECTRICAL SHOCK.

NOTE: Have a qualified service technician repair the leakage problem and add water to the unit. Ensure that the red "low water" light is on when the kettle is upright. On tilting kettles, it is normal for the red light to come on when the kettle is in a tilted position.

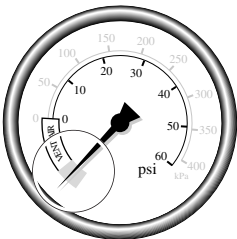
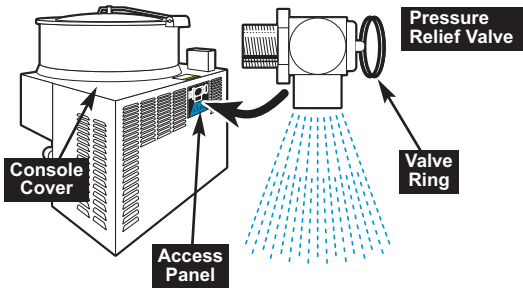

1. Ensure kettle is at room temperature and pressure gauge showing zero or less pressure.
2. Shut off power to the kettle at the fused disconnect switch.

3. Remove Console Cover and Access Panel.

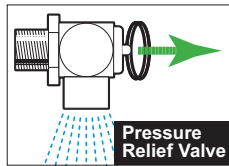

Important- Pull ring on Pressure Relief Valve prior to removal to insure vessel is not pressurized.



Sight Glass

4. Pull Pressure Relief Valve Ring open to insure vessel is not pressurized.
5. Remove 1/4" copper tubing and reducer bushing.
6. Add distilled water using a funnel if necessary. Fill the unit to the high level mark on the Sight Glass.
7. Apply a thread sealant (i.e. Teflon tape) to the reducer bushing threads and replace.
8. Replace Console Cover and Access Panel.
9. Restore power to unit at the fused disconnect switch.
10. The kettle must now be vented. (Refer to the KETTLE VENTING INSTRUCTIONS).

Kettle Capacity	Gallons (Ounces)
40 gallon	2 (256)
60 gallon	2.25 (288)
80 gallon	3.5 (448)
100 gallon	4 (512)

Approximate Amount Required

PRESSURE RELIEF VALVE PERIODIC TESTING

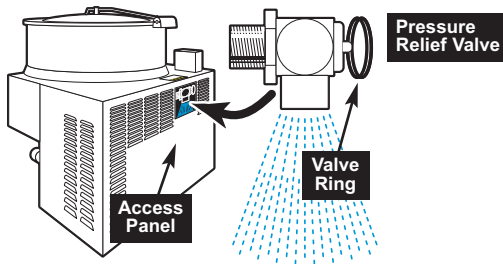

Most insurance agencies require periodic testing of pressure relief valves used on pressure vessels. This procedure will allow you to safely and quickly test your kettle's pressure relief valve. We recommend this test be performed twice a year.

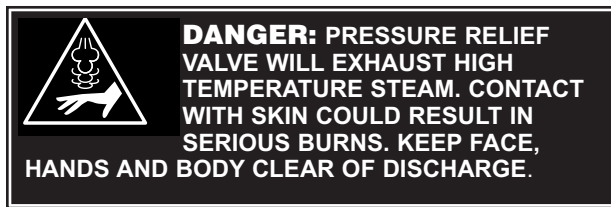

NOTE: The following instruction is intended for use by qualified service personnel.

WARNING: Kettle surface will be hot and steam will be released during testing. Take necessary precautions including the use of gloves and eye protection to prevent personal injury.

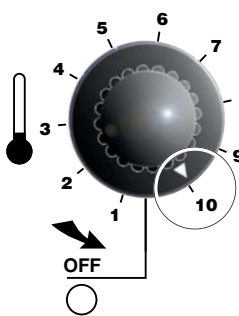

1. With the kettle empty, turn unit ON and set temperature control to **10**. Allow the kettle to heat until the unit cycles off.
2. Switch unit OFF and disconnect main power at fused disconnect switch.
3. Remove Access Panel at back of main kettle console.
4. Pull Pressure Relief Valve Ring open for a maximum of one second. Repeat test three to four times. Each time the mechanism should move freely and be accompanied by a rapid escape of steam.

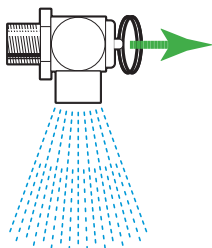

NOTES:

If valve appears to be sticking replace pressure relief valve.

If foreign material is discharged then drain kettle and replace pressure relief valve.

See KETTLE JACKET CLEANOUT & PASSIVATION PROCEDURES for full instructions on the correct method for draining and refilling kettle jacket.

WARNING: Improper refilling of kettle jacket will result in irreversible damage to unit.

5. Replace Access Panel.

6. Reconnect main power at fused disconnect switch..

CALIBRATING PROCEDURE

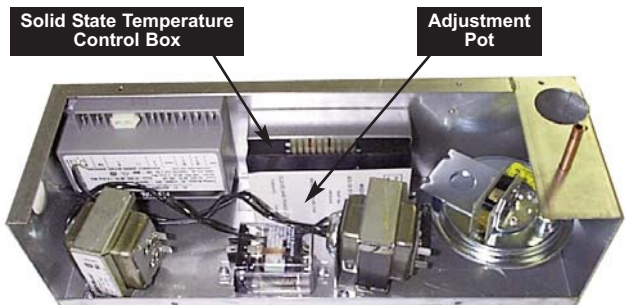

1. Insure the unit has a vacuum before you begin calibrating procedures. If unit requires venting refer to KETTLE VENTING INSTRUCTIONS.

2. Turn kettle ON and set temperature control to **10**.

3. Allow the unit to cycle twice.

4. Check temperature of the inner kettle surface with a digital surface thermometer.

5. Temperature should be between 260°F and 265°F.

6. Using a screw driver adjust temperature by turning the potentiometer on the Solid State

Temperature Control Box. Turn very little. Turn clockwise to INCREASES and counter-clockwise to DECREASE temperature.

7. Allow the unit to cycle twice.

8. Check temperature of the inner kettle surface with a digital surface thermometer.

9. Repeat steps **4.** through **8.** until unit is calibrated.

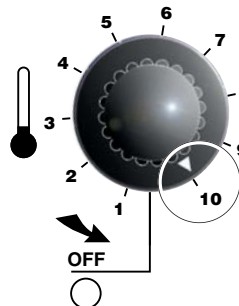

KETTLE JACKET CLEANOUT AND PASSIVATION PROCEDURES

The following procedure should be performed at least once every three years to prevent possible corrosion and ensure the optimum life of the kettle.

WARNING:
IMPROPER REFILLING OF KETTLE JACKET WILL RESULT IN IRREVERSIBLE DAMAGE TO UNIT.

DANGER:
MOLYFILM 315 IS CORROSIVE, AVOID CONTACT WITH SKIN AND EYES.

DANGER:
AVOID INHALATION - VAPORS FROM MOLYFILM 315 MAY BE HARMFUL OR FATAL.

DESCRIPTION - Molyfilm 315 inhibits corrosion in stainless steel and copper. A pH buffer is present to assist in maintaining the appropriate pH to assist in corrosion inhibition.

DISPOSAL - Follow all Federal, State and local codes when disposing of product.

SHELF LIFE - Molyfilm 315's effectiveness will diminish after three years.

REFILL QUANTITIES (ORDERING INFO: 1 Liter Molyfilm 315 Rust Inhibitor - Part# KE600340-1)

IMPORTANT: To ensure satisfactory mixing follow the MIXING / FILLING PROCEDURE described below.

Kettle Size	Volume of Water		Volume of Molyfilm 315		
	U.S. Gal.	Liters	oz.	cc	(ml.)
40 U.S. Gal.	6.5	24.5	7.8	230	
60 U.S. Gal.	6.6	25.0	8.9	260	
80 U.S. Gal.	7.0	26.5	9.5	280	
100 U.S. Gal.	7.4	28.0	10.2	300	

MIXING / FILLING PROCEDURE

1. Refer to chart to determine the required volumes of water and Molyfilm 315.
2. In a separate container mix 1/2 gallon of the required volume of water with the total required volume of Molyfilm 315.
3. Pour mixture into kettle.
4. Pour the remaining required volume of water into kettle.

DANGER:
PRESSURE RELIEF VALVE WILL EXHAUST HIGH TEMPERATURE STEAM. CONTACT WITH SKIN COULD RESULT IN SERIOUS BURNS. KEEP FACE, HANDS AND BODY CLEAR OF DISCHARGE.

DANGER:
WORKING ON MACHINES WITH POWER COULD RESULT IN SEVERE ELECTRICAL SHOCK.

DANGER:
EXTREMELY HOT SURFACES. WORK ONLY ON COLD KETTLE.

Flushing Procedure

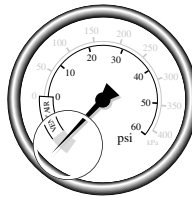

1. Ensure kettle is at room temperature and pressure gauge showing zero or less pressure.
2. Shut off gas supply.
3. Remove electrical plug from power source.
4. Remove console cover and access panel.
5. Pull pressure relief valve ring open to insure vessel is not pressurized.
6. Remove 1/4" copper tubing and reducer bushing.
7. Remove drain plug cap and allow kettle to drain. Flush out as much debris as possible with water.
8. Apply a thread sealant (i.e. Teflon tape) to the drain plug cap and replace.
9. Fill kettle jacket with a mixture of water and Molyfilm 315 (see REFILL QUANTITIES chart).
10. Apply a thread sealant (i.e. teflon tape) to the reducer bushing threads and replace copper tubing and reducer bushing.
11. Turn kettle on, vent and heat on high for 1/2 hour.
12. Cool and drain kettle as per above procedure.

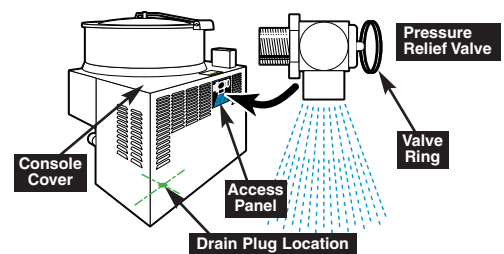

Refilling Unit

1. Apply a thread sealant (i.e. Teflon tape) to the drain plug cap and replace.
2. Fill kettle jacket with a mixture of water and Molyfilm 315 (see REFILL QUANTITIES chart).
3. Apply a thread sealant (i.e. teflon tape) to the reducer bushing threads and replace.
4. Replace console cover and access panel.
5. Restore power to unit at the fused disconnect switch.
6. Vent kettle. See Kettle Venting Instructions.

GAS KETTLE ORIFICE REPLACEMENT

NOTE: Use thread sealant compatible with propane gas on all threaded piping connections.

1. Disconnect electrical connection.
2. Shut off main gas supply and disconnect kettle from supply line.
3. Remove main kettle **CONSOLE COVER**.
4. Remove **PLUG** and **SPRING**.
5. Remove **GAS ORIFICE** and **"O" RING**.
6. Replace first with new **"O" RING** and then **GAS ORIFICE**.
7. Replace **SPRING** and **PLUG**.
8. Replace main kettle **CONSOLE COVER**.
9. Reconnect electrical supply.

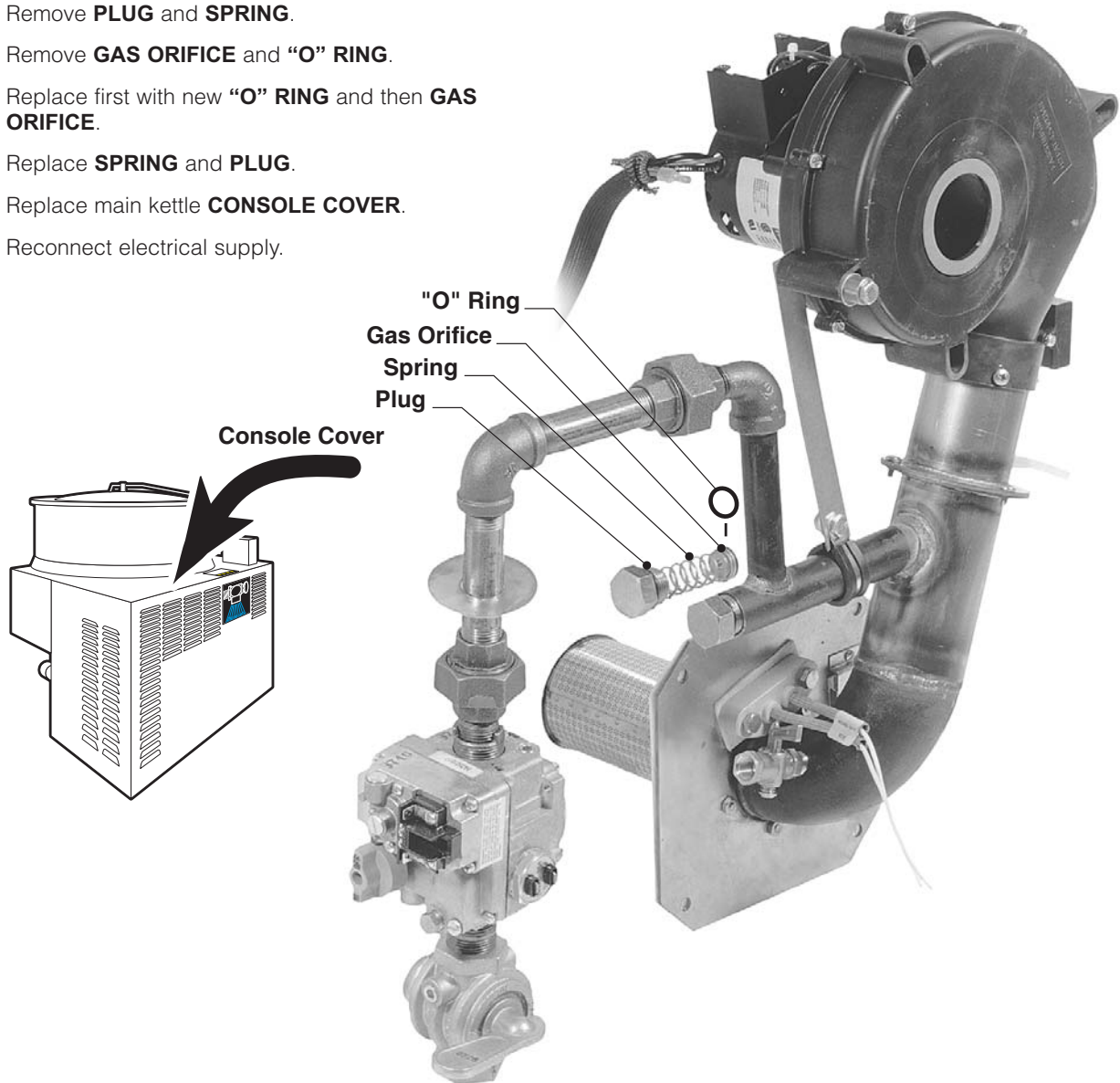

Kettles	BTU's per Hour	Gas Type	Water Column	# of Orifices
KGL-40,	140000	Natural Gas	3.5	1
KGL-40-T,	140000	Propane	3.5	1
KGL-60 to 100,				
KGL-60-T to 80-T,	190000	Natural Gas	3.5	1
KGL-40-TSH,	190000	Propane	3.5	1
KGL-40-F to 60-F,				
KGL-40-SH to 60-SH,				

FIELD CONVERSION INSTRUCTIONS

Natural Gas to Propane Gas

Kettles	BTU's per Hour	Gas Type	Water Column	# of Orifices
KGL-40,	140000	Natural Gas	3.5	1
KGL-40-T,	140000	Propane	3.5	1
KGL-60 to 100,	190000	Natural Gas	3.5	1
KGL-60-T to 80-T, KGL-40-TSH, KGL-40-F to 60-F, KGL-40-SH to 60-SH,		Propane	3.5	1

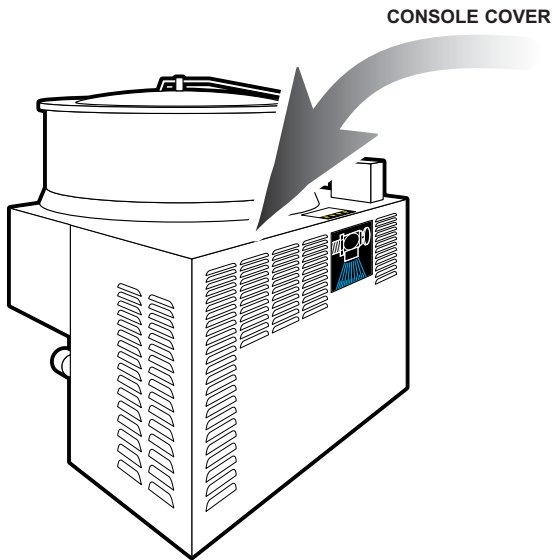

NOTE: Use thread sealant compatible with propane gas on all threaded piping connections.

1. Disconnect electrical connection.
2. Shut off main gas supply and disconnect kettle from supply line.
3. Remove main kettle **CONSOLE COVER**.
4. Remove **PLUG** and **SPRING**.
5. Remove **GAS ORIFICE** and **"O" RING**.
6. Replace first with new **"O" RING** and then **GAS ORIFICE**.
7. Replace **SPRING** and **PLUG**.
8. Replace main kettle **CONSOLE COVER**.
9. Reconnect electrical supply.

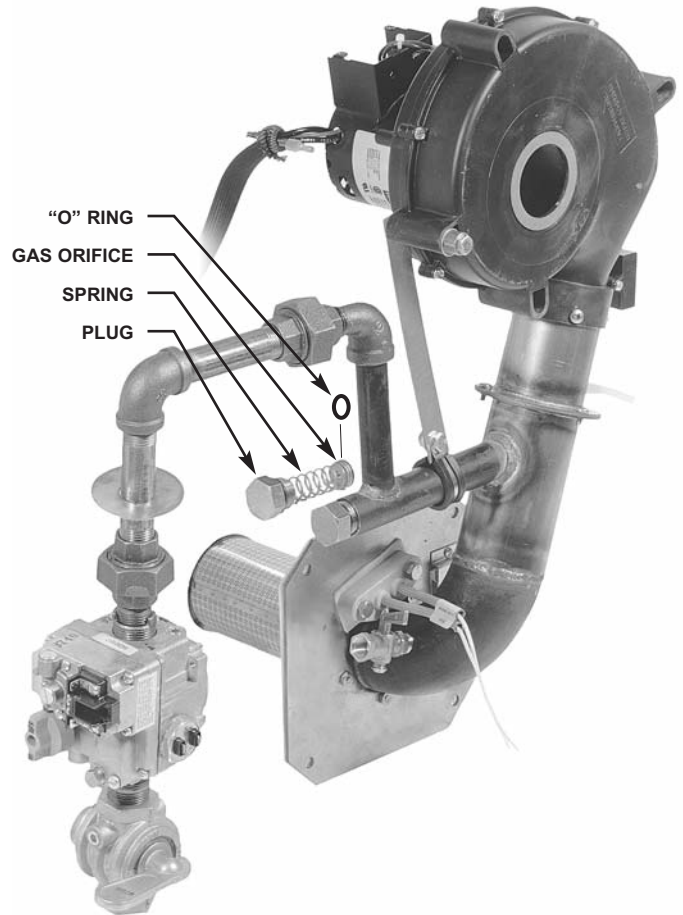

Conversion Parts Required

KGL-40

Part No.	Description	Quantity
KE95591	Conversion Label	1
KE54420-1	Air Intake Washer	1
KE53403-5	Gas Orifice	1
FA05002-29	"O" Ring	1

KGL-60 to 100

Part No.	Description	Quantity
KE95591	Conversion Label	1
KE54420-1	Air Intake Washer	1
KE53403-7	Gas Orifice	1
FA05002-29	"O" Ring	1



NOTE: Changing the gas type requires a new Rating Label be affixed to the unit.

When ordering conversion parts, it is essential to provide both the Model # and the Serial # of the unit in order to facilitate completion of this label in the factory.

TROUBLESHOOTING GUIDES (continued)

PROBLEM:
KGL
Kettle Won't
Heat

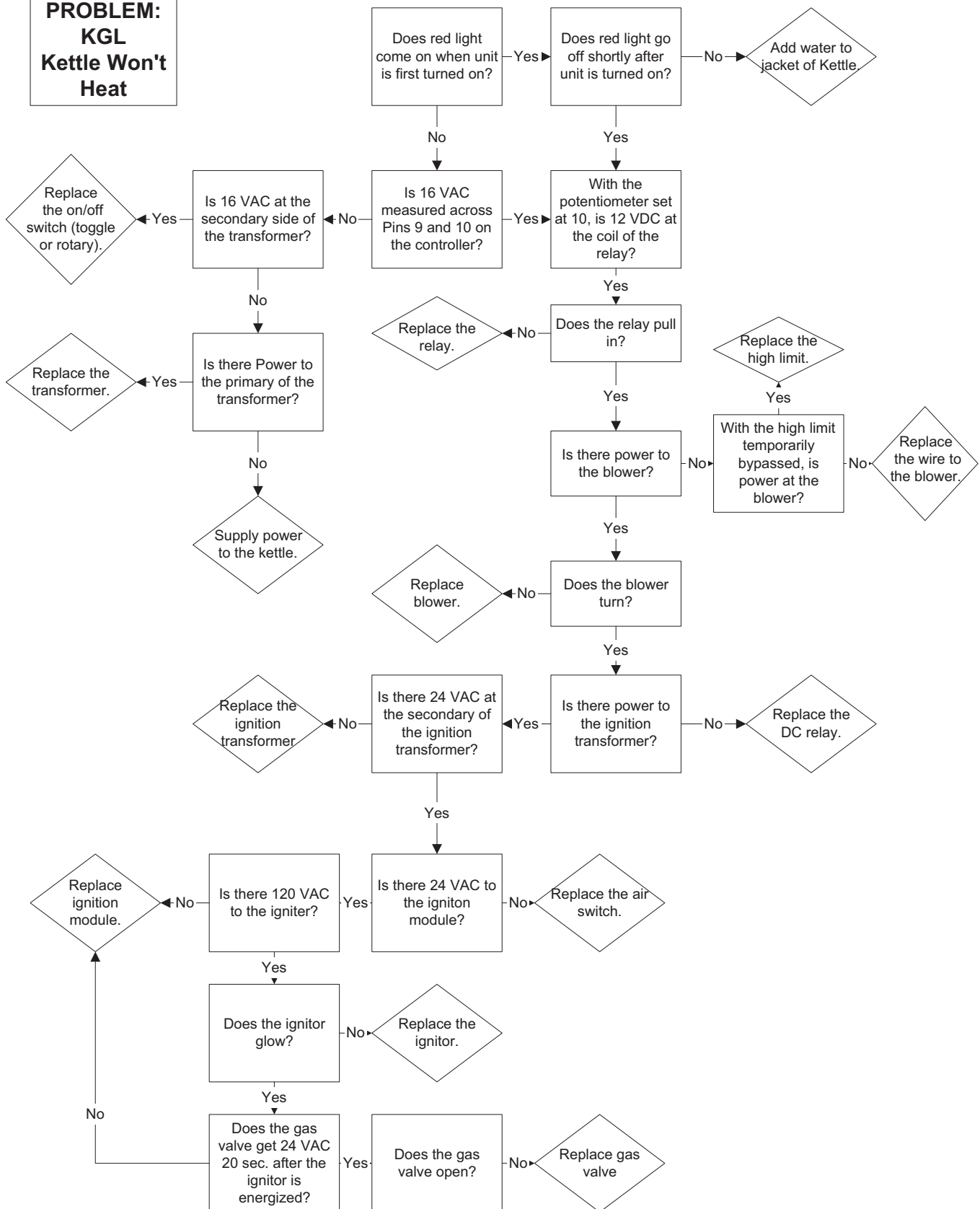

TROUBLESHOOTING GUIDES (continued)

**PROBLEM:
KGL
Kettle Not
Hot Enough**

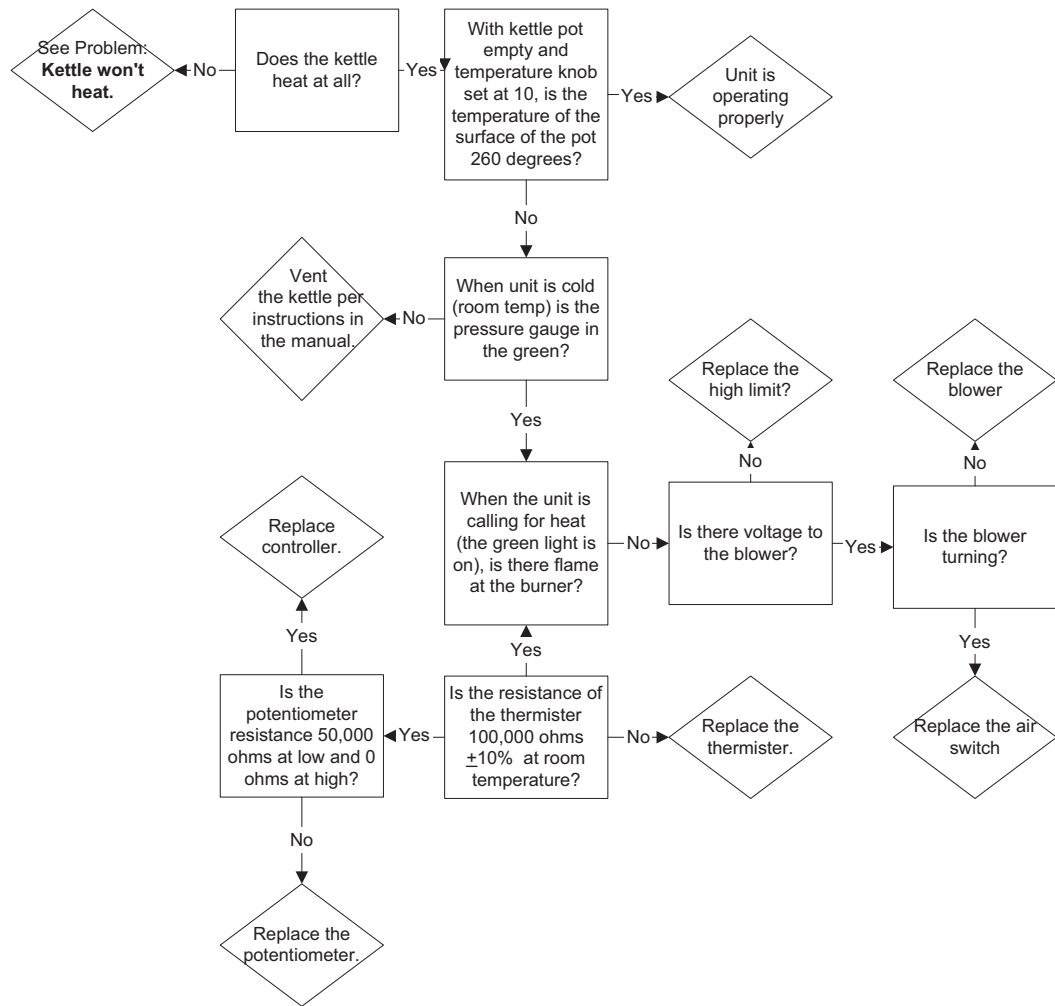

PROBLEM: KGL Kettle Has Delayed Ignition

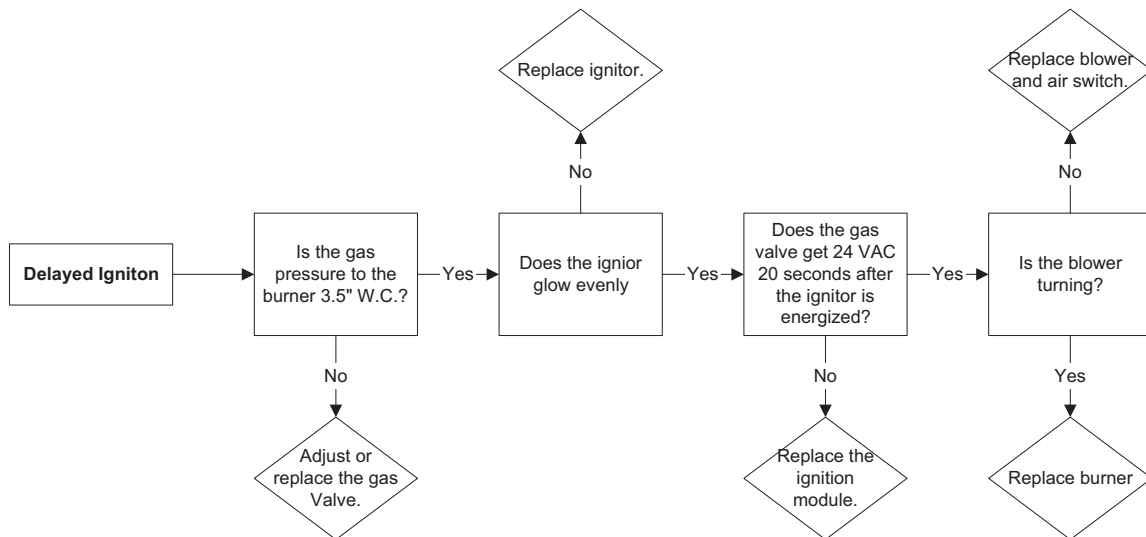

TROUBLESHOOTING GUIDES (continued)

**PROBLEM:
KGL Kettle
Gets Too
Hot**

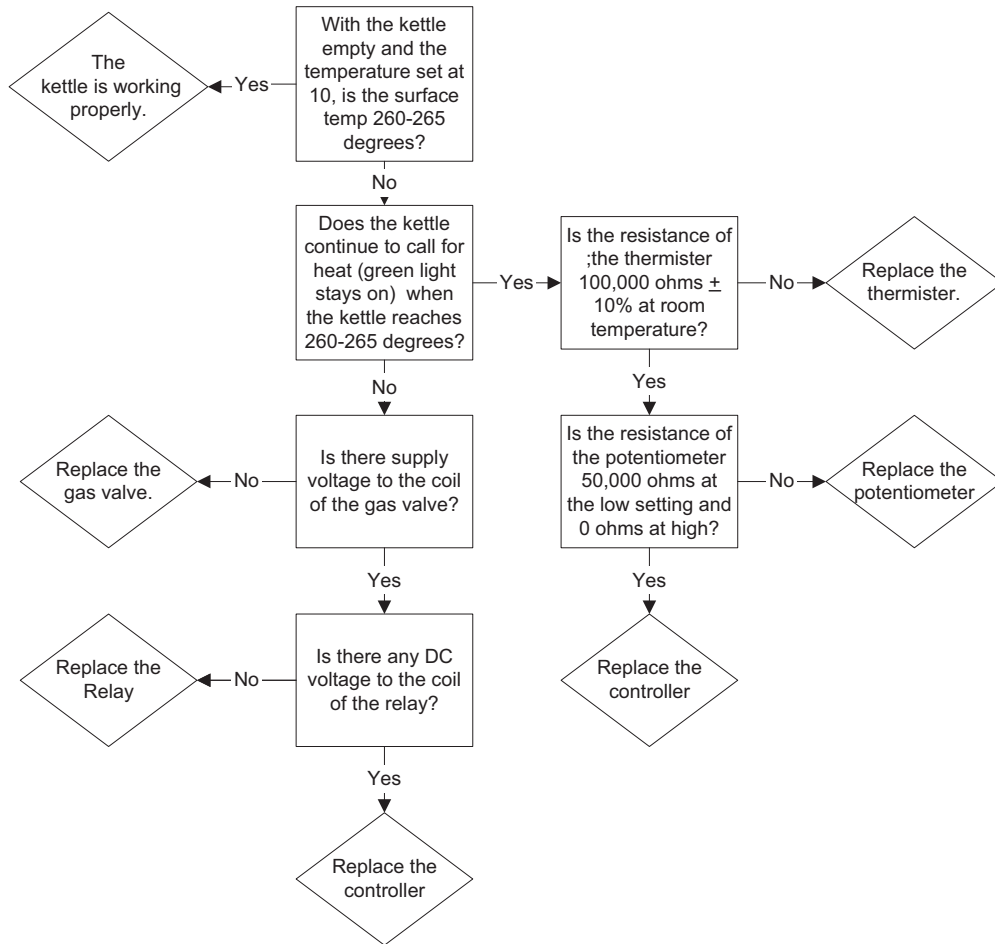

PROBLEM: Red Add Water LED Stays On

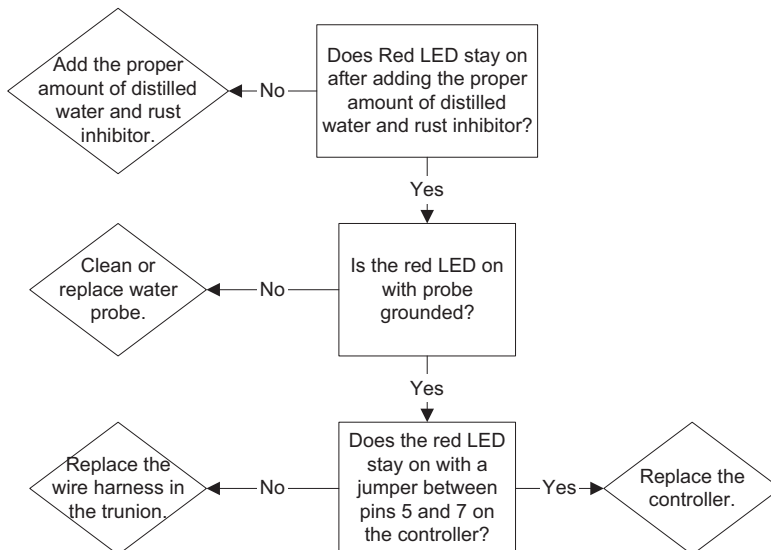

FLOW PATH FOR HYDRAULIC SYSTEM

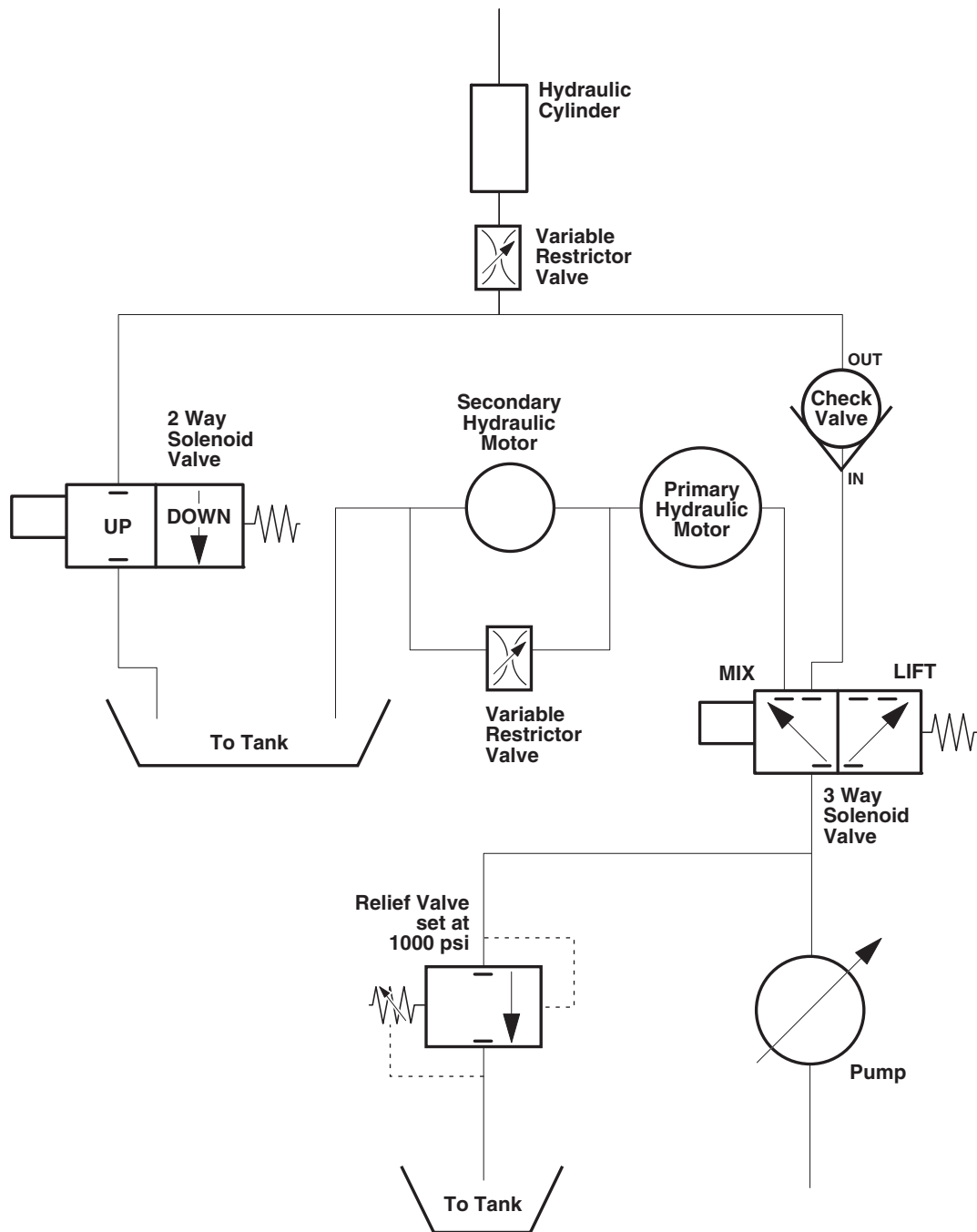

WIRING DIAGRAMS

Diagram #1

(see Diagram #4 for common parts):

MKGL-T shown with all options except automatic temperature control

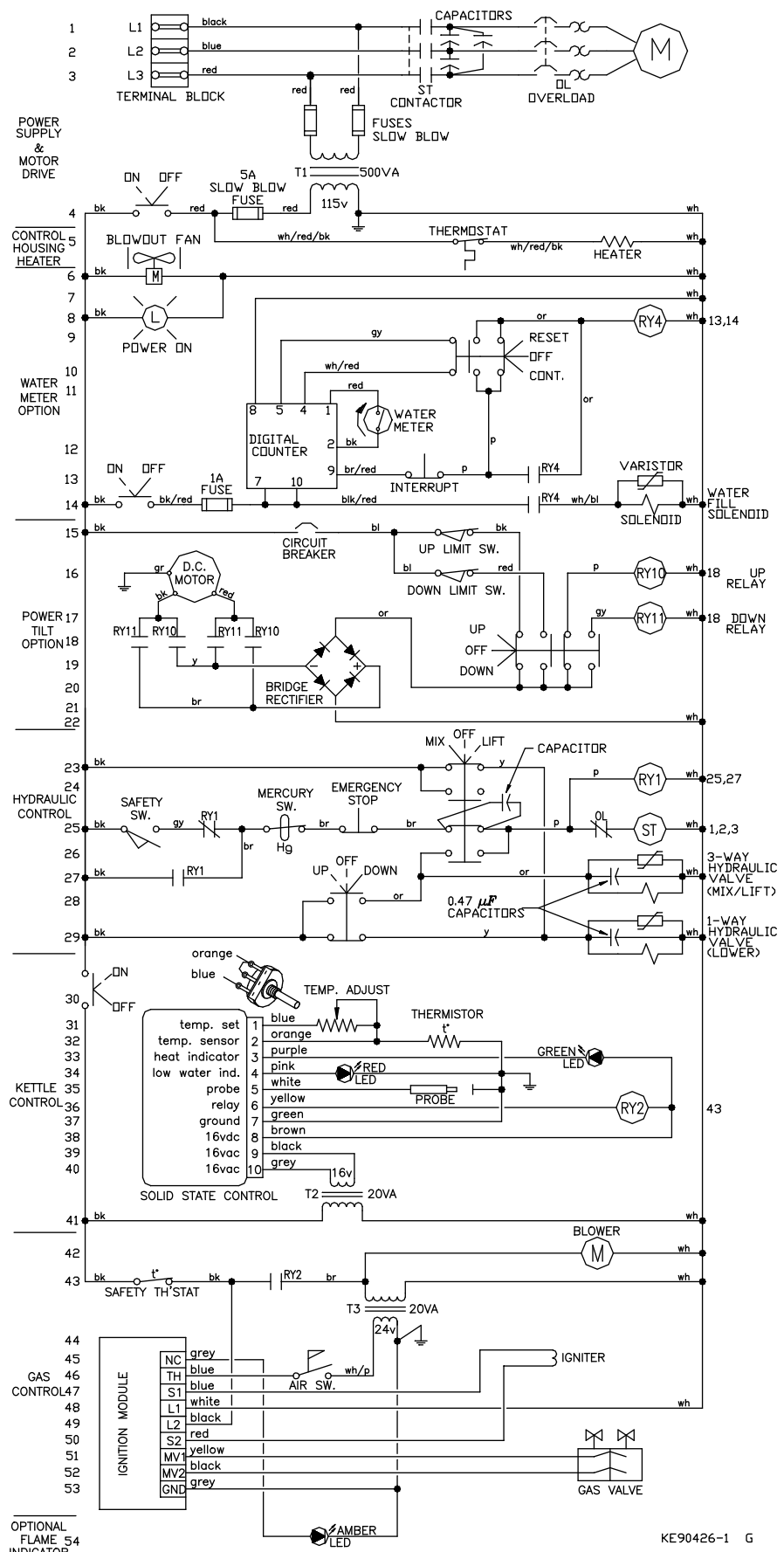

KE90426-1 G

MKGL-T WITH ALL THE OPTIONS EXCEPT AUTOMATIC TEMPERATURE CONTROL

Diagram #2

(see Diagram #4 for common parts):

MKGL-T shown with all options

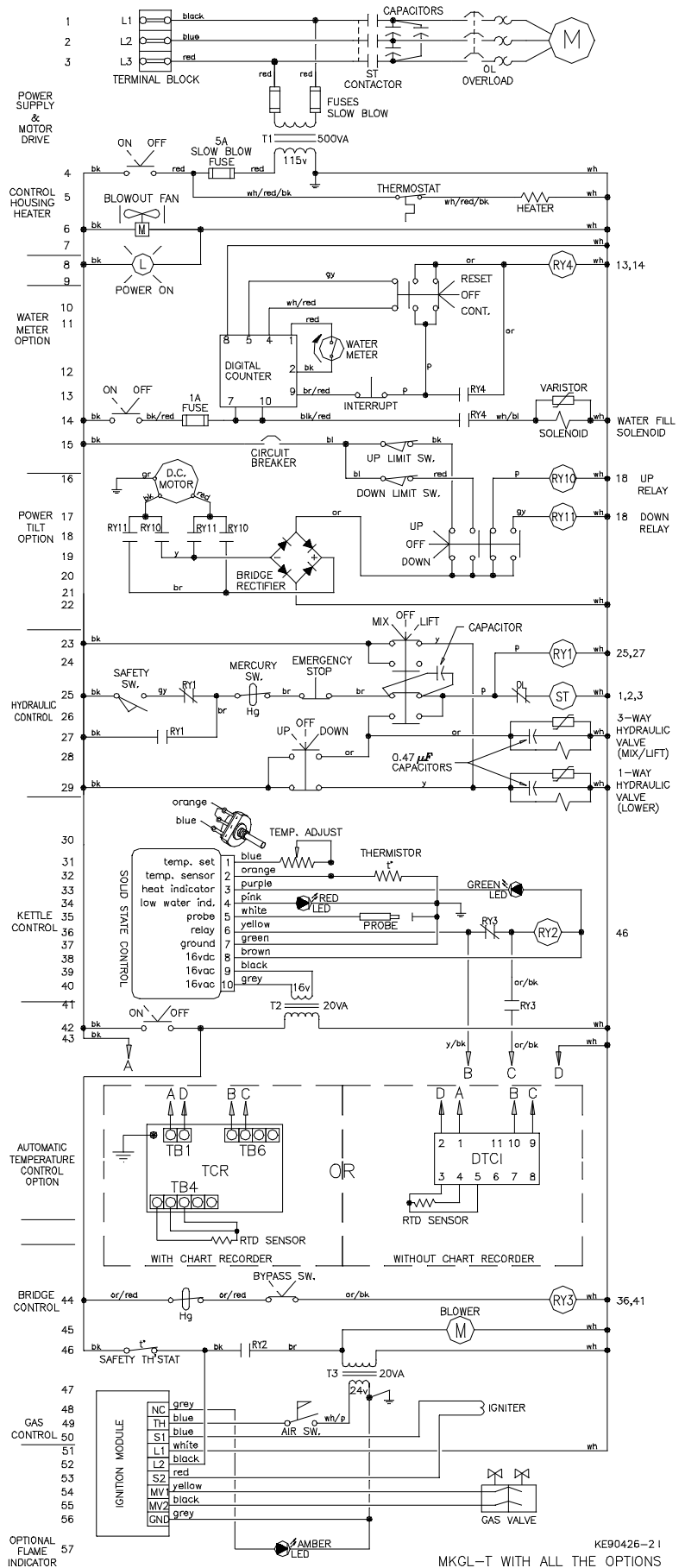
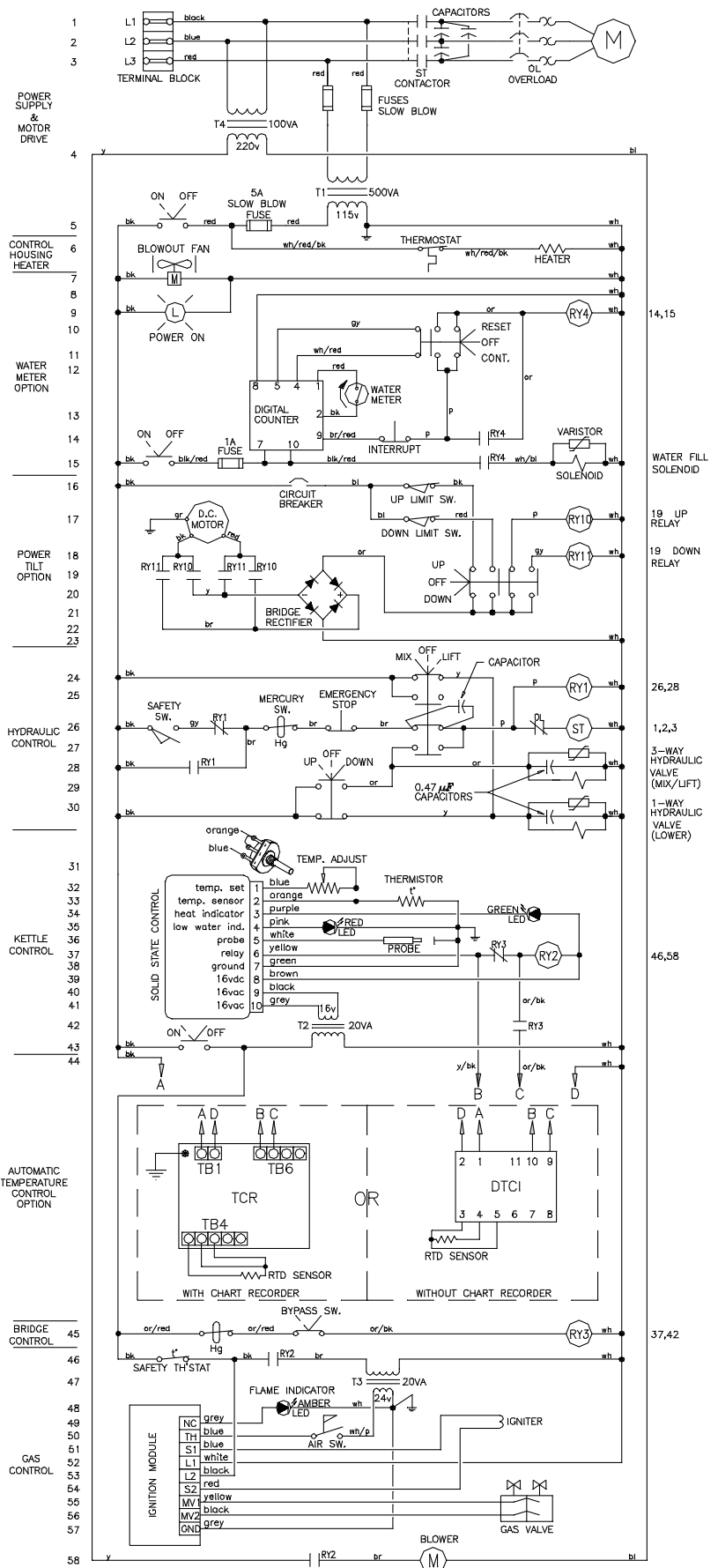

Diagram #3

(see Diagram #4 for common parts):
 MKGL-T shown with all options (French only)



MKGL-T WITH ALL THE OPTIONS (CE)

Diagram #4

Common Parts

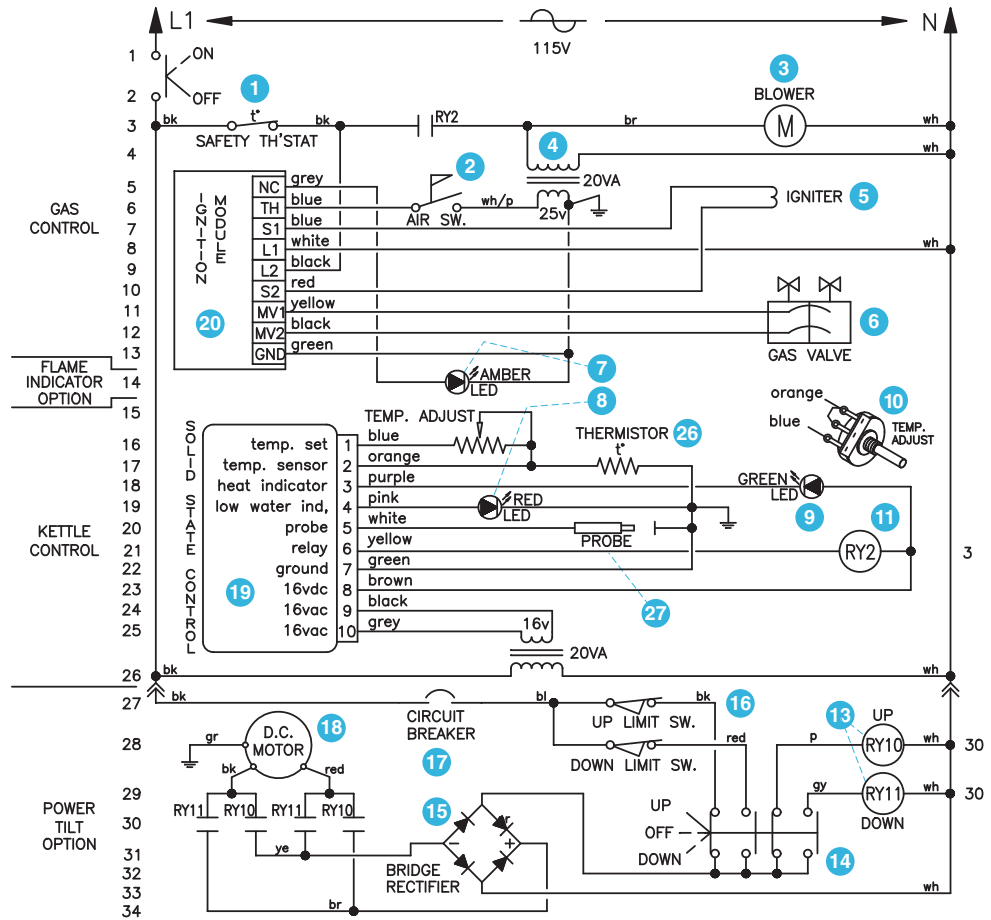

ITEM NO.	PART NO.	DESCRIPTION	QTY.
1	KE55069-6	SAFETY THERMOSTAT	1
2	KE53436	AIR PRESSURE SWITCH	1
3	KE53441	BLOWER, 115V, 60 HZ	1
4	KE53838-20	TRANSFORMER 120-24V	1
5	KE53437	IGNITER	1
6	KE53515	GAS VALVE	1
7	KE50567-2	L.E.D., AMBER (USED PRIOR TO JULY 2004)	1
8	KE50567-1	L.E.D., RED	1
9	KE50568-1	L.E.D., GREEN	1
10	SE00114	POTENTIOMETER WITH ON/OFF SWITCH	1
11	KE50753-7	RELAY, 120V	1
12	KE53838-20	TRANSFORMER 120-24V	1
13	KE50753-10	RELAY	2
14	FA20047	JAM NUT 5/16-24	1
	KE603208-4	MOMENTARY SWITCH ACTIVATOR	1
	KE603208-7	CONTACT SECTION HOLDER (LATCH)	1
15	KE50581	BRIDGE RECTIFIER	1
16	KE51007	MICRO SWITCH	2
17	KE50579	CIRCUIT BREAKER	1
18	KE52832	MOTOR "BODINE" #NSH-54RL	1
19	KE00458	KETTLE SOLID STATE CONTROL BOX	1
20	KE00458	KETTLE SOLID STATE CONTROL BOX	1
26.	KE00515	THERMISTOR	1
27.	KE50556-2	WATER LEVEL PROBE	1

SPARE PARTS LIST

ITEM ON.	DESCRIPTION	QTY. DOMESTIC	QTY. OVERSEAS
Spare Parts			
KE00458	Kettle solid state control box	1	1
KE50753-7	Relay, 120V	1	1
KE55069-6	Safety thermostat	1	1
SE00114	Potentiometer with ON/OFF Switch, c/w Rubber Boot	1	1
KE50569-1	Knob, Potentiometer	1	1
KE00515	Thermistor	1	1
KE50580	Water resistant boot	1	1
FA00012	"O" ring, circuit breaker	1	1
KE50581	Bridge rectifier	1	1
KE50753-10	Relay	2	2
KE54941-5	1/2" FPT, 50 psi., for ASME kettles	---	1
KE54941-31	1/2" FPT, 50 psi., for CE kettle	---	1
KE53838-27	Transformer, 120-14V.	---	1
KE53469-4	Ignition control module	---	1
KE53436	Air pressure switch	---	1
KE53838-20	Transformer 120-24V	---	1
KE50567-1	L.E.D., Red	---	1
KE50568-1	L.E.D., Green	---	1
KE50567-2	L.E.D., Amber (Used prior to July 2004)	---	1
KE50429-2	Pressure Gauge	---	1
KE53437	Ignitor	---	1
KE02053	Gas Valve Assembly	---	1
KE603208-4	Momentary switch activator	---	1
KE603208-7	Contact section holder (latch)	---	1
KE603208-9	Contact block	---	4
SE50426	Air Filter Element	1	1
SE50428	"O" Ring for Air Filter	1	1
KE52895	Air Regulator	---	1
KE52936	Fuse	1	1
KE003209-1	Switch Assembly - On/Off - Maintained	---	1
KE003209-3	Switch Assembly - On/Off/On - Maintained	---	1
KE003209-6	Switch Assembly - Momentary Spring Return	---	1
KE003209-7	Switch Assembly - Momentary Spring Return	---	1
KE02274	Capacitor Assembly	2	2
KE603208-8	Capacitor Cartridge - NC	2	2
KE603208-9	Capacitor Cartridge - NO	2	2
KE50753-10	Relay	2	2
KE00860	Cable and Bracket Assembly - Speed Control	---	1
SE50224	Solenoid Valve Coil	---	1
KE53962	Blade Stop Ring	2	2
KE51834	Scraper Blades	2	2
SE50094	Oil Filter	1	1
KE52668	Solenoid Valve, 3/8"	---	1
KE603208-9	Contact Block	---	1
FA00016	"O" Ring for Faucet Spout	2	2
SK50445	Fuse - 3 amps	1	1
SK52936	Fuse - 1 amps	1	1
KE50750-1	Contacting	---	1

FLUSH PISTON VALVE

FA05000	"O" Ring for Cylinder Head	5	5
KE52347	Sani-Clamp Seal - 4"	5	5
KE52344	Sani-Clamp 4"	---	1
FA00152	"O" Ring for Cylinder Body	4	4
FA00225	"O" Ring for Piston	4	4

BUTTERFLY VALVE

SE50433	Seat - 2"	---	1
SE50433-1	Seat - 2"	---	1