

# MIXER KETTLE, ELECTRIC FLOOR TYPE, LEVER TILT 2/3 JACKETED

Project \_\_\_\_\_  
 Item \_\_\_\_\_  
 Quantity \_\_\_\_\_  
 FCSI Section 11400 \_\_\_\_\_  
 Approved \_\_\_\_\_  
 Date \_\_\_\_\_

## Models

- MKDT-20-T



## Standard Features

- Infinitely Variable Speed for all conditions; Scraper from 0-70 rpm, Agitator from 0-210 rpm
- Removable (without tools) Nylon Blade scrapes entire Jacketed surface
- 3/4 Horsepower D.C. Timing Belt Drive
- Safety Device prevents high speed starts
- Mixing stops when Bridge is lifted
- Agitator and Scraper are bayonet mounted for easy removal
- Enclosed, balanced, 10 Gauge Stainless Steel Mixer Bridge
- Kettle and all exterior surfaces are stainless steel
- Steam Control Valve built into Trunnion
- Factory installed Steam Control Kit
- 50 psi Steam Jacket Rating
- Tilt Handle interchangeable for left or right operation
- Large Pouring Lip
- Double Pantry Faucet Standard
- Gallon Markings on Scraper Shaft
- Standard 120 volts, 60 Hz, single phase, 3 wire
- Typical approvals include NSF and ASME

## Short Form Specifications

Shall be Cleveland, model MKDT-20-T, Floor Type, Lever Tilt, 20 gallon, Direct Steam Mixer Kettle, 50 psi Jacket Rating, Factory Installed Steam Control Kit, Steam Control Valve built into Trunnion. Infinitely Variable Speed, 3/4 H.P. Time Belt Drive, Bayonet Mounted Agitator and Scraper with removable Blades, Safety Device prevents high speed starts. Mixing stops when Bridge is lifted. Kettle and all Exterior Surfaces are Stainless Steel.

## Options & Accessories

- Covers (MTP)
- Product Time/Temperature Controls and Indicators
- Food Strainer (FS-12)
- Flow Diverter (FD)
- Kettle Accessory Kit (KAK) includes:
  - Clean-up Brush (CB)
  - 36" Kettle Paddle (KP)
  - 36" Kettle Whip (KW)
  - 36" Kettle Brush (KB)
  - Draw-off Brush (DB)
  - 24 oz. Ladle (KL)
- Pressure Reducing Valve (PRV-K)
- Type 316 Stainless Steel Kettle Interior for high acid food products (316-12G)
- Water Meter (GMF or LMF) Wall Mount or on Stand (SWM)

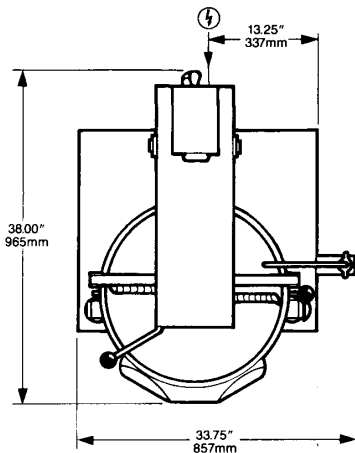

•ACTUAL CAPACITIES: (in 4 oz. servings) (Other sizes may be calculated.)  
20 Gallon / 80 liters . . . . .704

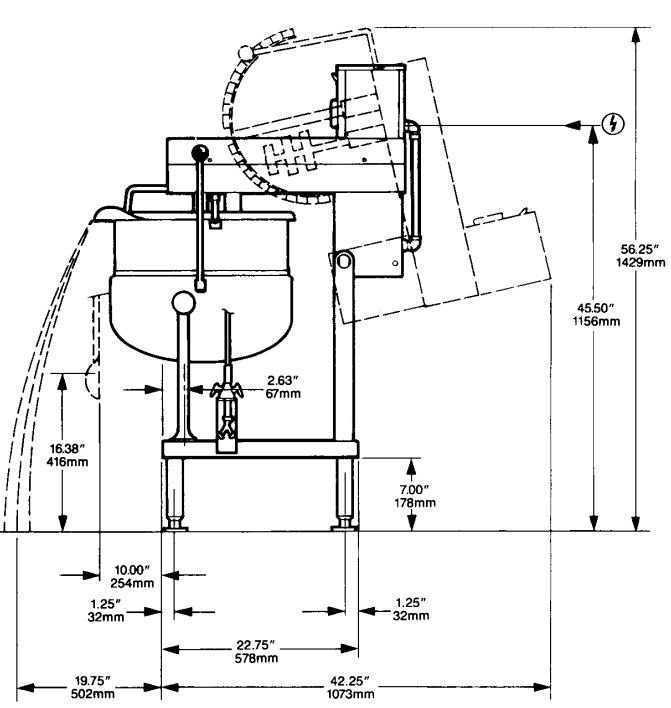
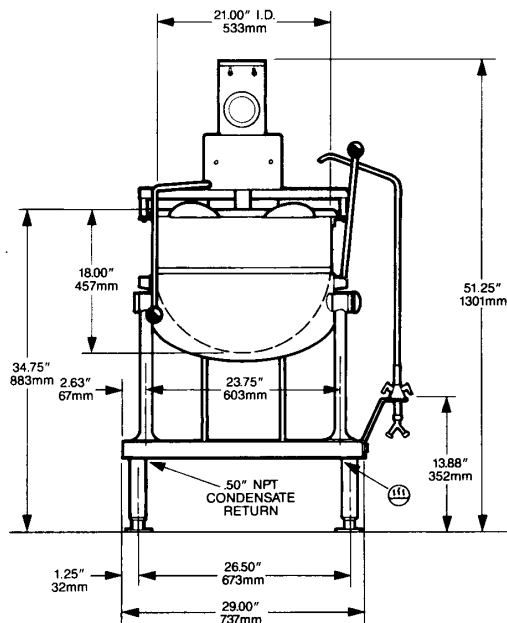

DIRECT STEAM (☁)	ELECTRIC (⚡)	CLEARANCE						
Steam supply: Furnish 1/2" IPS min. line. Operating pressure 5 to 45 psi with a 50 psi safety valve.	120V, 1PH	RIGHT = 0" LEFT = 0" REAR = See drawing						
	<table border="1"> <thead> <tr> <th>GALS.</th> <th>LITERS</th> <th>HP</th> <th>AMPS</th> </tr> </thead> <tbody> <tr> <td>20</td> <td>80</td> <td>3/4</td> <td>7.5</td> </tr> </tbody> </table>		GALS.	LITERS	HP	AMPS	20	80
GALS.	LITERS	HP	AMPS					
20	80	3/4	7.5					

**NOTES:**  
 Cleveland Range reserves right of design improvement or modification, as warranted.  
 Many regional, state and local codes exist and it is the responsibility of the owner and installer to comply with the codes.  
 Installation of backflow preventers, vacuum breakers and other specific code requirements is the responsibility of the owner and installer.  
 Cleveland Range equipment is built to comply with applicable standards for manufacturers. Included among those approval agencies are U.L., A.G.A., NSF, ASME/N.Bd., CSA, CGA, ETL and others. (NOT TO SCALE)