

# Maintenance Procedures & Parts Lists

Metering Filling Station

*For units built after August 2011*

MFS



*For your future reference.*

Model # \_\_\_\_\_

Serial # \_\_\_\_\_

Model # & Serial #.  
(Open front panel to view rating label.)

 **Cleveland**

1333 East 179th St., Cleveland, Ohio, U.S.A. 44110  
Ph: 216.481.4900 Fx: 216.481.3782  
[www.clevelandrange.com](http://www.clevelandrange.com)



***Read the manual thoroughly.  
Improper installation, operation or  
maintenance can cause property  
damage, injury or death.***

*This manual is to be used in conjunction with the  
“Operators Manual”. See “Operators Manual” for  
safety warnings, correct operation, installation  
and preventative maintenance.*

 **Manitowoc**

# **STATEMENT OF RESPONSIBILITIES / DÉCLARATION DES RESPONSABILITÉS / DECLARACIÓN DE RESPONSABILIDADES**

This document is for use by experienced and trained Qualified Cleveland Range, LLC Authorized Service Representatives who are familiar with both the safety procedures, and equipment they service. Cleveland Range, LLC assumes no liability for any death, injury, equipment damage, or property damage resulting from use of, improper use of, or failure to use the information contained in this document. Cleveland Range, LLC has made every effort to provide accurate information in this document, but cannot guarantee that this document does not contain unintentional errors and omissions.

The information in this document may be subject to technical and technological changes, revisions, or updates. Cleveland Range, LLC assumes no liability or responsibility regarding errata, changes, revisions, or updates.

Qualified Cleveland Range, LLC Authorized Service Representatives are obligated to follow industry standard safety procedures, including, but not limited to, OSHA regulations, and disconnect / lock out / tag out procedures for all utilities including steam, and disconnect / lock out / tag out procedures for gas, electric, and steam powered equipment and / or appliances.

All utilities (gas, electric, water and steam) should be turned OFF to the equipment and locked out of operation according to OSHA approved practices during any servicing of Cleveland Range equipment

Qualified Cleveland Range, LLC Authorized Service Representatives are obligated to maintain up-to-date knowledge, skills, materials and equipment.

Ce document est destiné à l'usage des Représentants de Service qualifiés et autorisés de Cleveland Range, LLC qui possèdent l'expérience et la formation ainsi que la bonne connaissance des mesures de sécurité et du matériel qu'ils entretiennent.

Cleveland Range, LLC décline toute responsabilité pour tout cas de décès, blessure, dommage matériel ou dommage aux biens résultant de l'utilisation, de la mauvaise utilisation ou du manquement d'utilisation des renseignements contenus dans ce document.

Cleveland Range, LLC s'est efforcé à fournir des renseignements précis dans ce document mais ne peut garantir que ce document soit exempt d'erreurs et d'omissions non intentionnelles.

Les renseignements contenus dans ce document peuvent être assujettis à des changements techniques et technologiques, des révisions ou des mises à jour.

Cleveland Range, LLC décline toute obligation ou responsabilité concernant les errata, modifications, révisions ou mises à jour.

Les Représentants de Service qualifiés et autorisés de Cleveland Range, LLC sont tenus de se conformer aux mesures de sécurité normalisées de l'industrie, y compris, mais sans s'y limiter, les réglementations de l'OSHA, les procédures de débranchement / verrouillage / étiquetage relatives à tous les services publics, dont l'approvisionnement en vapeur, et les procédures de débranchement / verrouillage / étiquetage relatives aux équipements et/ou appareils fonctionnant au gaz, à l'électricité et à la vapeur.

Au cours de tout entretien d'un appareil Cleveland Range, tous les services publics (gaz, électricité, eau et vapeur) doivent être FERMÉS au niveau de l'appareil et le dispositif de fonctionnement doit être verrouillé suivant les pratiques approuvées de l'OSHA.

Les Représentants de Service qualifiés et autorisés de Cleveland Range, LLC sont tenus d'actualiser en permanence leurs connaissances, compétences, matériel et équipement.

Este documento está destinado para el uso de los Representantes de Servicio calificados y autorizados de Cleveland Range, LLC quienes cuentan con la experiencia y la capacitación así como el buen conocimiento de las medidas de seguridad y de los equipos que mantienen.

Cleveland Range, LLC, declina toda responsabilidad en caso de cualquier fallecimiento, lesiones, daños al equipo o daños a la propiedad resultantes de la utilización, del uso indebido o de la falta de utilización de la información provista en este documento.

Cleveland Range, LLC se ha esforzado en suministrar información precisa en este documento, pero no puede garantizar que este documento esté exento de errores y de omisiones no intencionales.

La información contenida en este documento podría estar sujeta a cambios técnicos o tecnológicos, revisiones o actualizaciones. Cleveland Range, LLC declina toda obligación o responsabilidad con respecto a erratas, modificaciones, revisiones o actualizaciones.

Los Representantes de Servicio calificados y autorizados de Cleveland Range, LLC tienen la obligación de seguir los procedimientos estándar de seguridad de la industria; los cuales incluyen pero no se limitan a los reglamentos de la OSHA (La Administración de la Seguridad y Salud Ocupacionales), los procedimientos de desconexión, cierre y etiquetado relativos a todos los servicios públicos incluyendo el suministro de vapor y los procedimientos de desconexión, cierre y etiquetado para los equipos y/o aparatos que funcionan a base de gas, electricidad o vapor.

Cuando se esté dando servicio o mantenimiento a un aparato de Cleveland Range, todos los servicios públicos (gas, electricidad, agua y vapor) deben estar APAGADOS para el equipo en cuestión y se debe seguir el procedimiento de cierre de operaciones de acuerdo con las prácticas aprobadas por la OSHA.

Los Representantes de Servicio calificados y autorizados de Cleveland Range, LLC tienen la obligación de actualizar constantemente sus conocimientos, destrezas, materiales y equipamiento.



# TROUBLESHOOTING AND MAINTENANCE PROCEDURES



*The following trouble shooting guide  
and maintenance procedures are meant  
to be used by Qualified Service Technician.*

**For periodic maintenance recommendations see “Operators Manual”.**

---

## TROUBLE SHOOTING GUIDE

(reference drawings at back of manual)

- 1.** If there is no air to unit check:

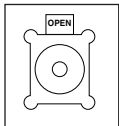

**A/** Check that the kettle's Air Quick Connect is pushed upward to the "OPEN" position.

- B/** Open the back access doors and check that the 3 way spool valve is pressed inwards.
- 2.** Make sure the air regulator (large black knob on back of panel) is turned on for pressure to enter system. To be sure enough pressure is in system, check for min. 60 PSI, otherwise valves might not shift.
- 3.** Recommended operating pressure is 90 to 100 PSI.
- 4.** If the unit seems to be covered in oil or the oil is dripping out of the mufflers, then turn lubricator output down. Correct setting is 1 drop every 10-15 strokes.

- 5.** If the pump valve does not shift during operation or is slow in shifting, make sure the two Legris flow controls are not adjusted right in. If so, then back them off.
- 6.** If pump cylinder is too slow then adjust large Aro flow controls to desired speed.
- 7.** If a leak develops around the air valve 5 bank manifold, tighten the screws on top of valve and tighten manifold socket head bolts as these can loosen over time.
- NOTE:** Be careful with socket head bolts - do not tighten too much or clamps will bend on manifold increasing the leak.
- 8.** If cylinder cycles one way but not back, check that the limit valves are hitting to make sure contact is made and signal is sent to either port 19 or 26 of the 5 station valve bank.
- 9.** If cylinder still does not cycle, check or replace control valve assembly of the 5 station valve bank.

## BASIC OPERATION

### Single Cycle Operation

Turn the selector switch to the single cycle. It will do the following when the start switch is hit:

- Shifts valve No. 2 second from the top which turns off valve No. 1 and takes the signal away from Pt. 24.
- Single cycle valve is now turned on. It gives a one shot of air to valve No. 3 which shifts, and turns on Group A.
- The pump valve now shifts (Airtec Valve) Pt. 1 and valve No. 4 & 5 shifts Pt. 11 & 12. This actuates Air Cylinder & Rotary Actuator.
- When the pump reaches its full stroke, it hits LV1. This shifts valve No. 3 back through Pt. 19 which turns on Group B which shifts the pump valve (Airtec Valve) at Pt. 2 and shifts the valves NO. 4 & 5 back through Pt. 22 & 23 which actuates the Air Cylinder and Rotary Actuator to complete the single cycle.

### Constant Pumping Path:

Turn the selector switch to constant pumping cycle. It will then do the following when the start switch is hit:

- Valve No. 2 shifts which in turn shifts valve No. 1 through Pt. 31. This turns on valve No. 3 through Pt. 24 if LV2 is actuated which turns on Group A.
- The pump valve now shifts (Airtec Valve) Pt. 1 and valve No., 4 & 5 shifts Pt. 11 & 12 to actuate Air Cylinder and Rotary Actuator.
- When pump reaches the full stroke it hits LV1. This shifts back Valve No. 3 through Pt. 19 which turns on Group B which shifts pump valve (Airtec Valve) at Pt. 2 and shifts back valve No. 4 & 5 through Pt. 22 and Pt. 23 which actuates the Air Cylinder and Rotary Actuator.
- When the pump completes the first cycle, LV2 is hit again and turns valve No. 1 back on and shifts valve No. 3 again through Pt. 24 and starts another cycle all over again.
- This will continue until the selector switch is turned off which turns off the air to valve No. 2 and stops supplying valve No. 1, which will not turn on valve No. 3 to start another cycle.

## ADJUSTMENT & SETTING OF AIR CUSHION EQUIPPED PUMP HEADS

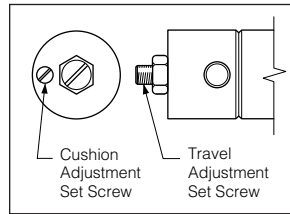

Figure 1

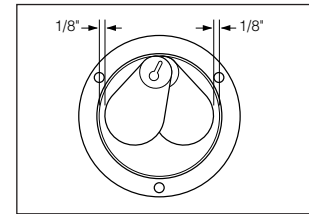

Figure 2

### SECTION 1 - Adjustment of Valve Paddle Travel

**NOTE:** When looking at the pump head (paddle side), left side paddle travel is affected by the right side air cylinder travel adjustment set screw and vice versa.

1. Back off 9/16" lock nut on 3/8" dia. set screw as shown in Figure 1.
2. Adjust set screw until valve paddle is 1/8" away from inside O-ring land edge as shown in Figure 2.
3. Secure lock nut.
4. Recheck 1/8" distance between paddle and edge.
5. This side is now set. Follow the same procedure for the other side.

### SECTION 2 - Setting of Air Cushion

**NOTE A:** Again left side paddle cushioning is affected by the right side air cylinder cushion set screw (3/16" dia.) and vice versa as shown in Figure 1.

**NOTE B:** Turning set screw in increases air cushion action and vice versa.

**CAUTION:** Avoid fingers around paddle travel area, personal injury may result.

1. Support the head assembly securely and connect the air lines to the rotary actuator air cylinders. Activate air to start rotary action.
2. Observe air cushion action at the end of each swing. Optimum cushion action can best be described as a controlled deceleration of the paddle at the end of the swing with complete elimination of rotational momentum in the shortest time possible. Adjust set screw to achieve results on both sides.

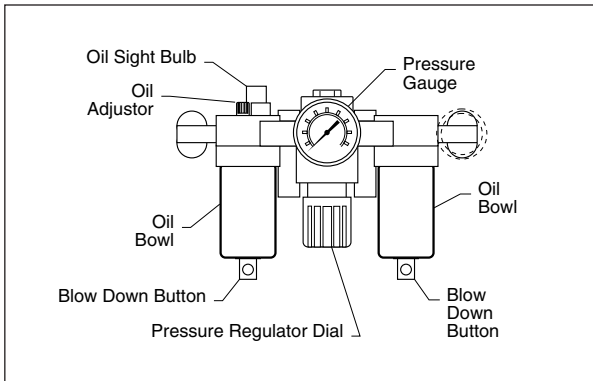

## AIR PRESSURE

1. Adjust air regulator or line pressure so that air pressure gauge reads 90 - 100 psi when unit is running on continuous cycle (stroke selector switch is set on "constant pumping").

## OIL FILLING PROCEDURE

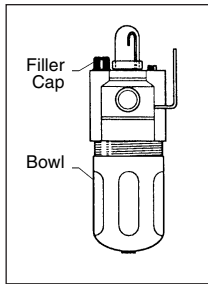

The lubricator puts one drop of oil into the air lines for every ten to fifteen cycles of the product piston. This ratio should be checked weekly and the oil level should be checked daily.

1. Drip Adjustment -
  - ⇒ Observe the sight bulb on the top of the oiler. One drop of oil into the lines for every ten to fifteen cycles of the product piston.
  - ⇒ If adjustment is necessary turn the adjustment knob next to the sight bulb clockwise for more oil, counter clockwise for less oil.
2. Adding Oil -
  - Use only mineral oil in the oiler.
  - ⇒ Remove air supply from unit.
  - ⇒ Remove oiler cage and bowl. Fill to line and replace.

## AIR FILTER REPLACEMENT PROCEDURE

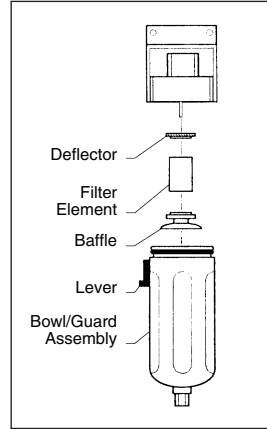

The air filter is designed to separate a small amount of dirt and water from the supply air. This filter is NOT designed to clean air straight from the compressor. You must install a separate filter and drier in the supply line to deliver air with a dew point of less than 65° F.

1. Check for water accumulation daily. If water is present, push button at the bottom of bowl and allow the water to spray out.

**NOTE:** If the bowl has to be drained regularly (more than once a week) then the supply air has not been sufficiently dried.

2. If the air cartridge is dirty then it should be replaced.
  - ⇒ Remove air connection from unit.
  - ⇒ Remove cage and bowl.
  - ⇒ Turn disk to the left to remove.
  - ⇒ Install new cartridge.

## PISTON TIMING

The amount of delay between the time the product piston reaches the end of a half stroke and the reversing of direction can be adjusted.

1. Remove the back panel.
2. The two flow controls are located to the left of the large shuttle valve on the right.

**NOTE:** The left flow control controls the delay after the discharge stroke is completed. The right flow control controls the the delay after the suction stroke is completed.

3. Loosen locking nut.
4. Set selector switch to continuous and have someone hold the tripper switch as you adjust the delay.
5. Retighten the locking nut.

# SERVICE PARTS

## WARRANTY

Our Company supports a worldwide network of Maintenance and Repair Centers. Contact your nearest Maintenance and Repair Centre for replacement parts, service, or information regarding the proper maintenance and repair of your cooking equipment

In order to preserve the various agency safety certification (UL, NSF, ASME/Ntl. Bd., etc.), only factory-supplied replacement parts should be used. The use of other than factory supplied replacement parts will void warranty.

## PISTON HEAD ASSEMBLY

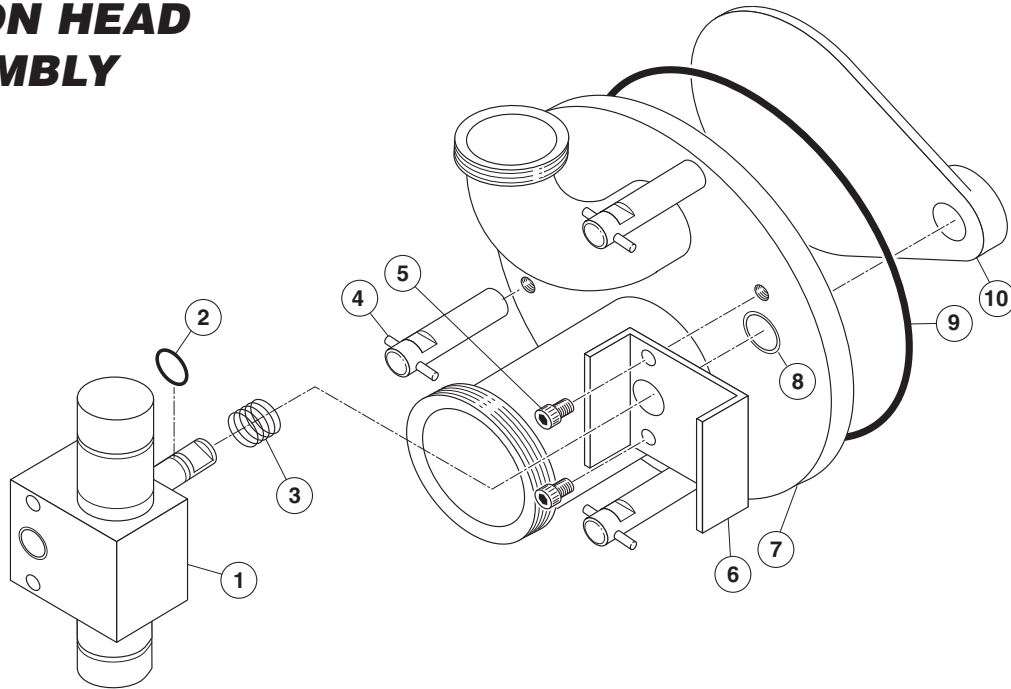

## PISTON HEAD ASSEMBLY

ITEM NO.	PART NO.	DESCRIPTION	QTY.
1. - 10.	SE00068-1	Pump head assembly	1
1.	KE53014-1	Rotary actuator	1
ROTARY ACTUATOR REPAIR KITS	SE50454	Bearing kit	1
	SE50455	Seal kit	1
	SE50455-1	Gear shaft assembly	1
2.	FA05002-24	"O" Ring, cylinder	1
3.	KE53056	Spring	1
4.	KE01302	Lug nuts	3
5.	FA11322-1	Hex cap screws	2
6.	KE53659-1	Bracket	1
7.	KE003731	End plate, includes 5 & 6	1
8.	KE53016	Bearing	1
9.	FA05002-2	"O" Ring, pump head	1
10.	KE603701	Valve Paddle	1

# PUMP ASSEMBLY

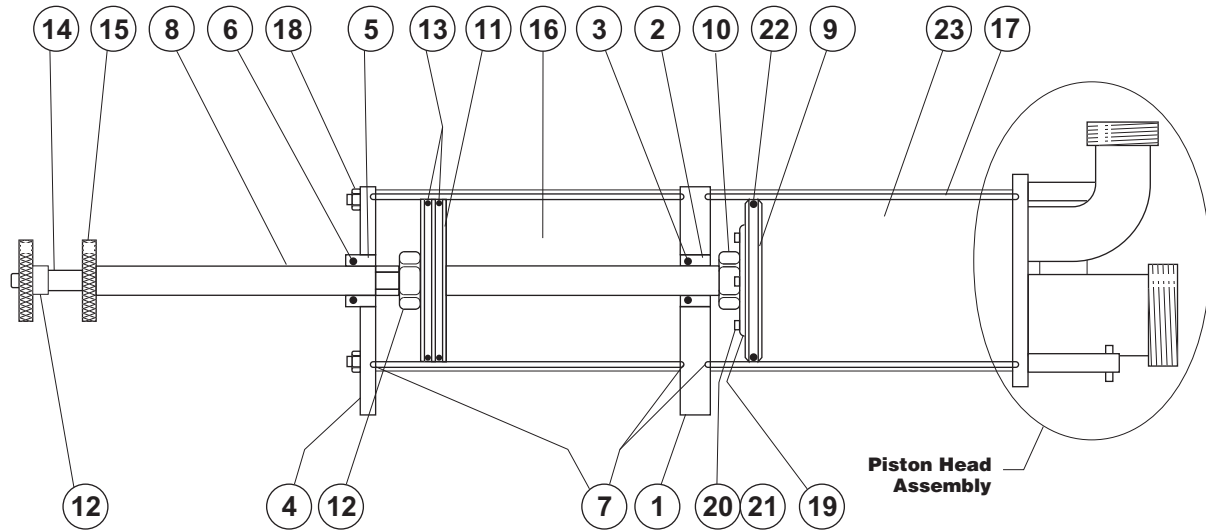

ITEM NO.	PART NO.	DESCRIPTION	QTY.
1.	KE53037	Centre Plate . . . . .	1
2.	KE53035	Piston Rod Bearing (Centre Plate) . . . . .	1
3.	FA05002-6	"O" Ring . . . . .	1
4.	KE53036	Pneumatic End Plate . . . . .	1
5.	KE53034	Piston Rod Bearing . . . . .	1
6.	FA05002-1	"O" Ring . . . . .	1
7.	FA05002-2	"O" Ring . . . . .	3
8.	KE01305	Piston Rod Assembly . . . . .	1
9.	KE53031	Product Piston . . . . .	1
10.	FA22502-1	Locknut, 1 1/4-7 . . . . .	1
11.	KE53030	Pneumatic Piston . . . . .	1
12.	FA22502-2	Locknut, 1 5/8-12 . . . . .	1
13.	FA05002-26	"O" Ring . . . . .	2
14.	KE01301	Adjustment Rod Weldment . . . . .	1
15.	KE53051	Adjustment Lock Ring . . . . .	1
16.	KE53039	Cylinder . . . . .	1
17.	KE53043	Reach Rod . . . . .	6
18.	FA21026	Hex Nut, 3/8-16 . . . . .	3
19.	KE54401	Backing Plate . . . . .	1
20.	FA11258	Hex. Head Bolt, 1/4-20 . . . . .	6
21.	FA32008	Tooth Lockwasher . . . . .	6
22.	FA05002-5	"O" Ring . . . . .	1
23.	KE02005	Product Culinder Assembly . . . . .	1
24.	KE54735	Spacer Nut . . . . .	1

# LABEL DISPENSER

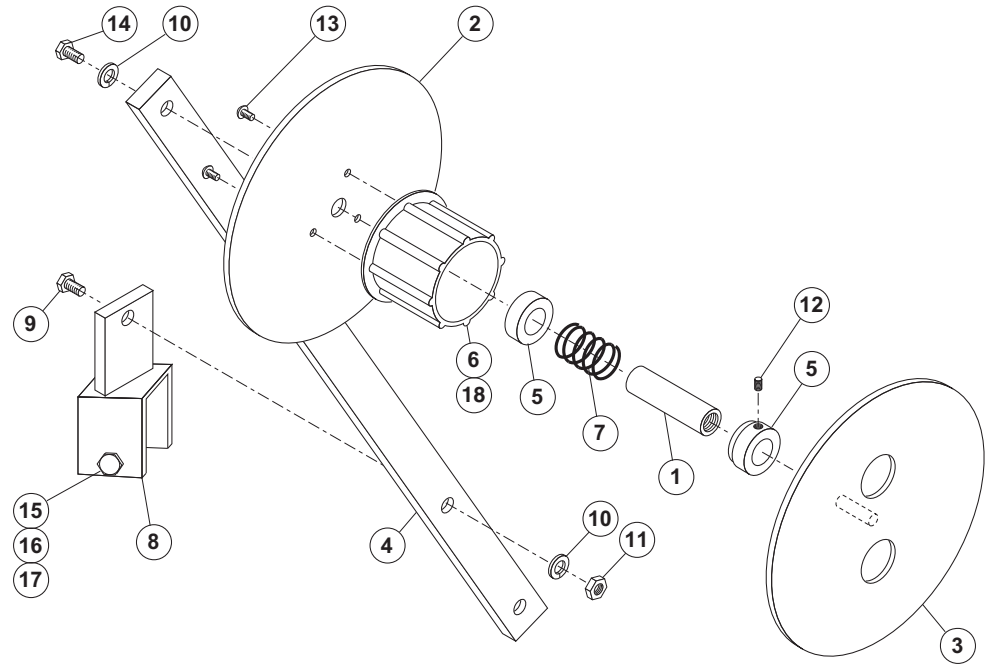

ITEM NO.	PART NO.	DESCRIPTION	QTY.
1-17	KE01387	Label Dispenser Assembly	1
1.	KE53186	Hub Mounting Shaft	1
2.	KE53187	Labeller Back Plate	1
3.	KE01386	Labeller Front Plate Assembly	1
4.	KE53268	Bar	1
5.	KE54139	Bushing	1
6.	KE53265	Core Holder	1
7.	KE53266	Spring	1
8.	KE01383	Labeller Mount	1
9.	FA11258	Hexhead Screw	1
10.	FA31029	Lock washer	2
11.	FA21008	Hex Nut, #1/4-20	1
12.	FA19500	Hex Socket	1
13.	FA11056	Binding Head Screw, #6-32x1/2" lg.	3
14.	FA11260	Hexhead Screw, #1/4-20x1" lg.	1
15.	FA11328	Hex Head Screw	1
16.	FA31030	Lock Washer	1
17.	FA21024	Hex Nut	1
18.	KE54751-2	Bushing	1

# HOSE ASSEMBLIES

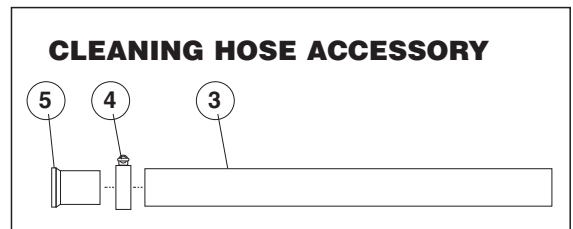
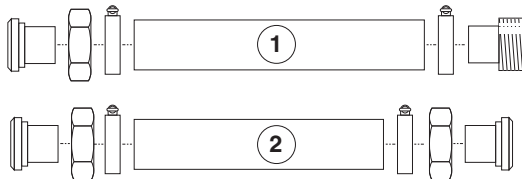

ITEM NO.	PART NO.	DESCRIPTION	QTY.
1.	KE01749-3	Food Hose Assembly, 3'	1
2.	KE01749-2	Food Hose Assembly, 3'	1
3.	KE55470-1	Cleaning Hose	1
4.	FI05220-2	Hose Clamp	1
5.	FI05255	Hose Adapter 2"	1

# MISCELLANEOUS PARTS

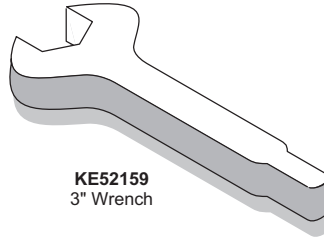
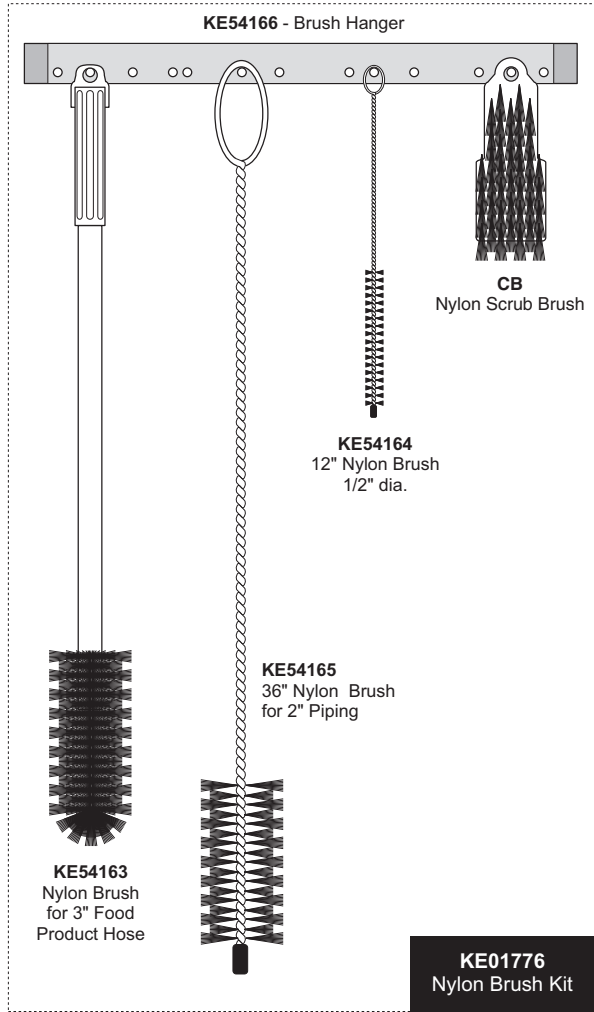

**KE52159**  
3" Wrench

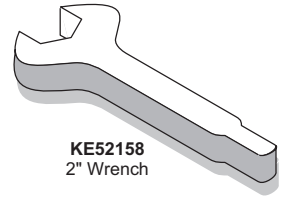

**KE52158**  
2" Wrench

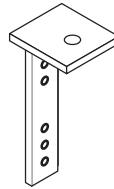

**KE00911**  
Swivel Plate

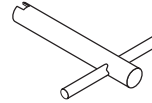

**KE01947**  
Lug Wrench



**KE55336-6**  
3" Elbow, 90°



**KE52095**  
Clipper Bar Clamp

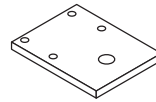

**KE52096**  
Clipper Clamp Plate

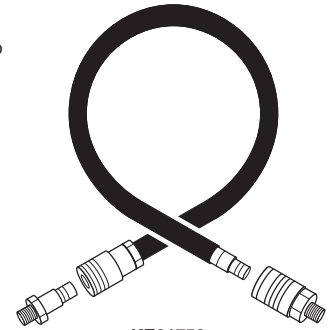

**KE01750**  
Hose for Metering Filling Station/Kettle  
1/2" dia. x 8' 6" lg.



**KE01518**  
Hose for Clipper  
3/8" dia. x 6' lg.

**KE003651-1RH**  
**KE003651-2LH**  
Trash Container  
Support Bar  
(old style)

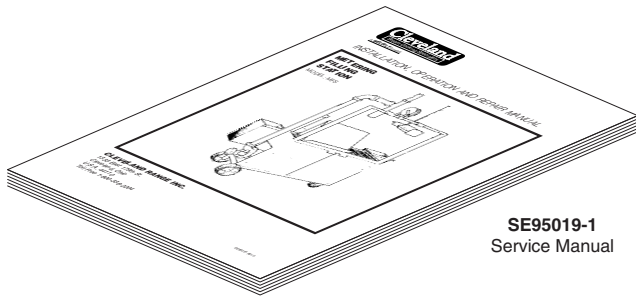
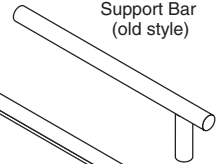

**SE95019-1**  
Service Manual



**Mineral Oil**  
(purchased locally)

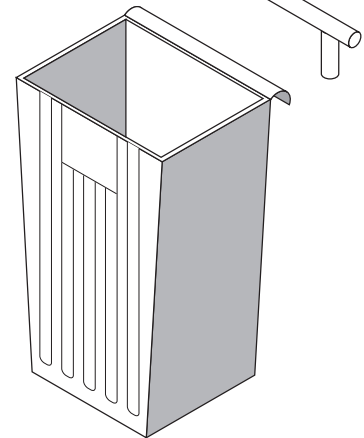

Trash Container  
**KE603751** (new style)  
**KE53081** (old style)

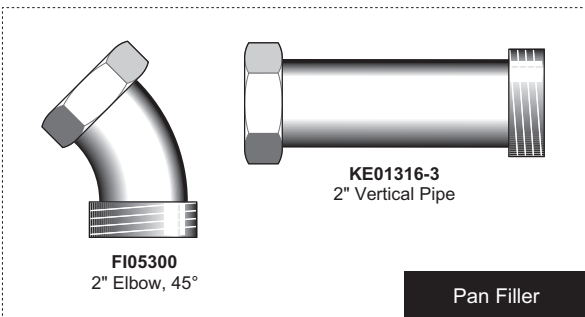

**FI05300**  
2" Elbow, 45°

**KE01316-3**  
2" Vertical Pipe

Pan Filler



**KE54167**  
Food Grade Grease

# PIPING ASSEMBLIES, "O" RINGS, GASKETS & SEALS

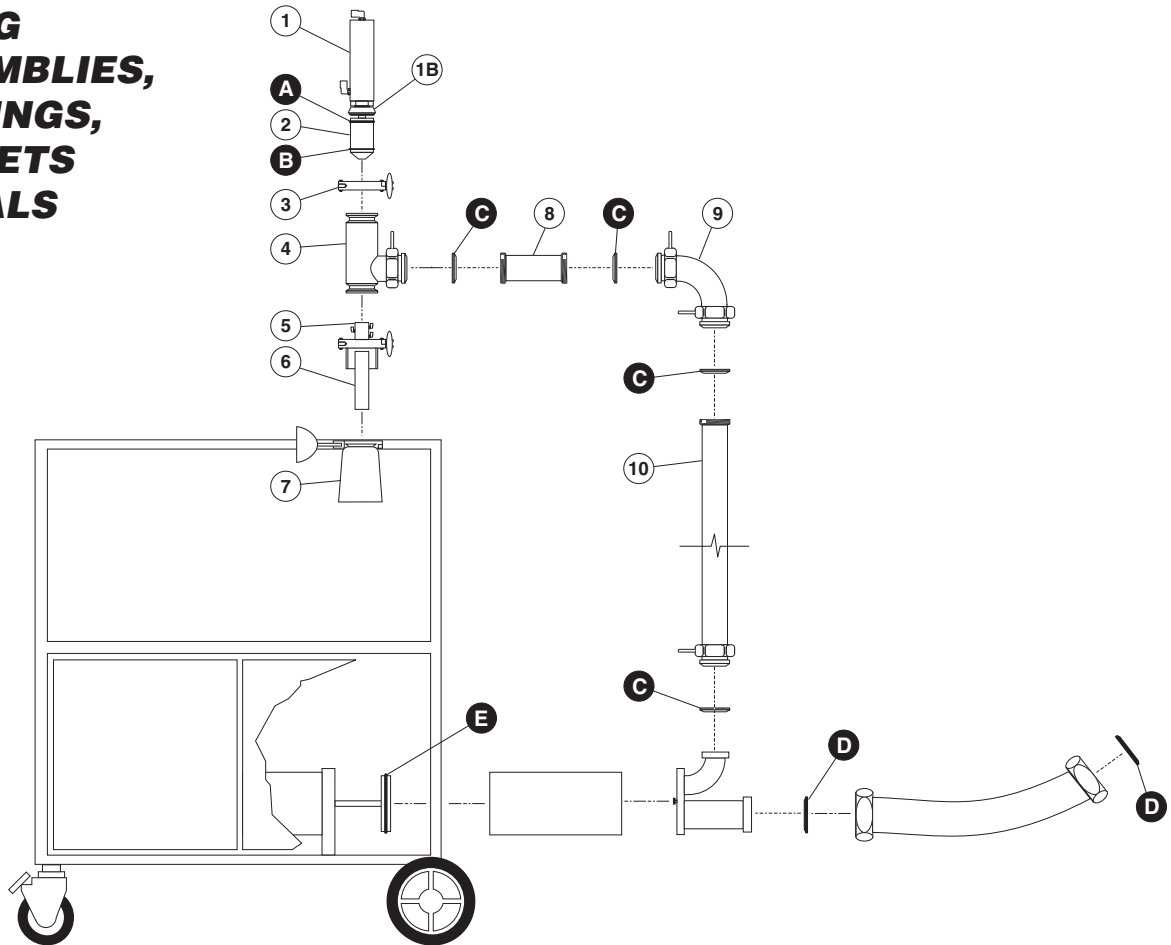

## PIPING ASSEMBLIES

ITEM NO.	PART NO.	DESCRIPTION	QTY.
1.	KE53270	Air Cylinder	1
1B.	KE53249	Mounting Nut, Air Cylinder	1
2.	KE53250	Plunger	1
3.	FI05144-1	Sani-clamp, 2"	Standard Configuration . . . . .1 Optional Strainer Configuration . . . . .3
4.	KE01385	Discharge Valve Body	1
5.	KE54287	Start Switch	1
6.	KE00905	Actuator Assembly	1
7.	KE01384	Discharge Nozzle	1
8.	KE00920	Short Connector Pipe, 2"	Standard Configuration . . . . .1
9.	KE01974	Elbow, 2"	1
10.	KE01316-1	Long Connector Pipe, 2"	Standard Configuration . . . . .1

## "O" RINGS, GASKETS & SEALS

ITEM NO.	PART NO.	DESCRIPTION	QTY.
A.	FA05002-3	Upper Plunger "O" Ring	1
B.	FA05002-7	Lower Plunger "O" Ring	1
C.	KE54810-2	Gasket, 2" Bevel Seat	Standard Configuration . . . . .4 Optional Strainer Configuration . . . . .2
D.	KE54810-3	Gasket, 3" Bevel Seat	2
E.	FA05002-5	Product Piston "O" Ring	1

# "O" RINGS, GASKETS & SEALS

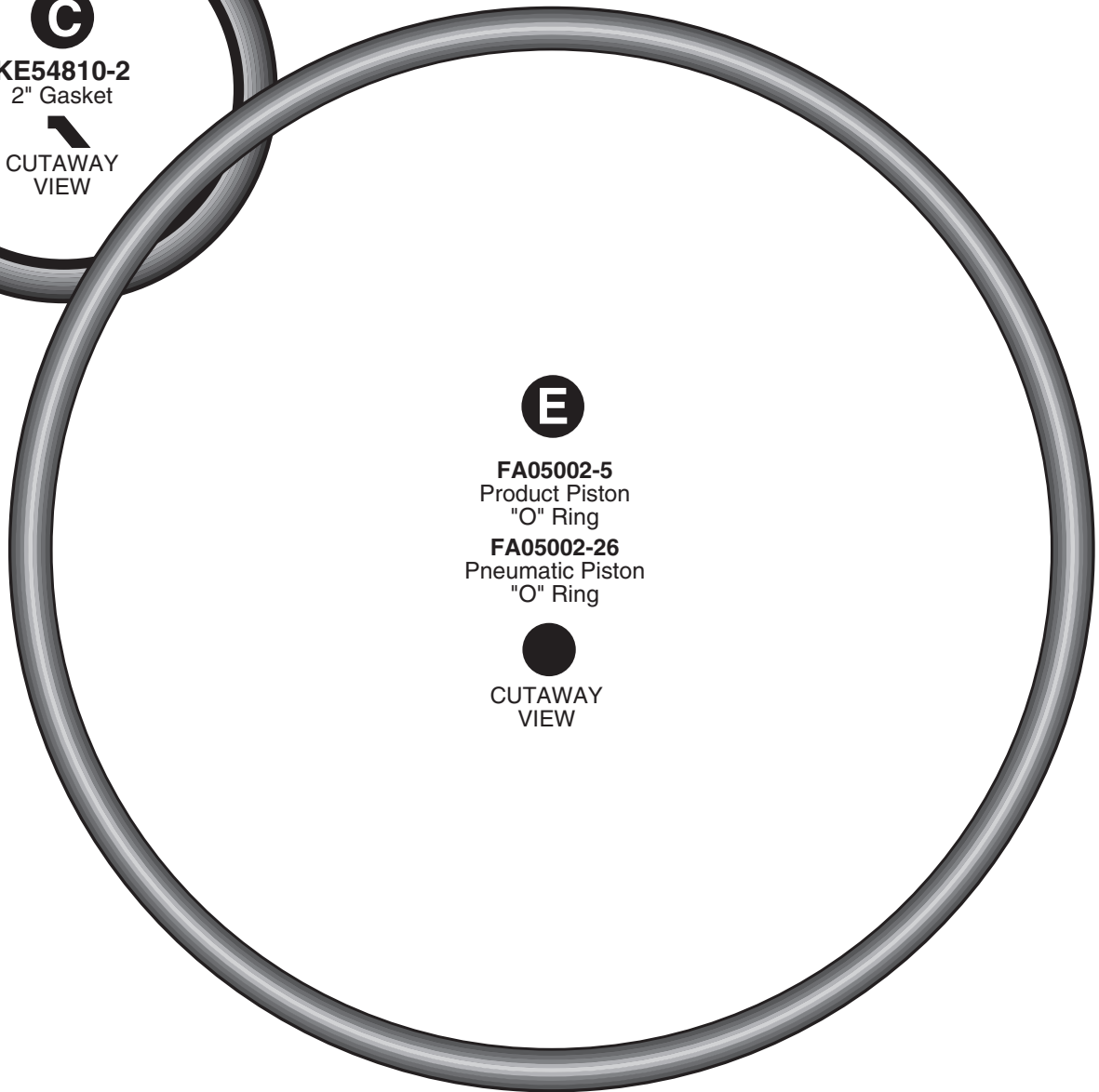
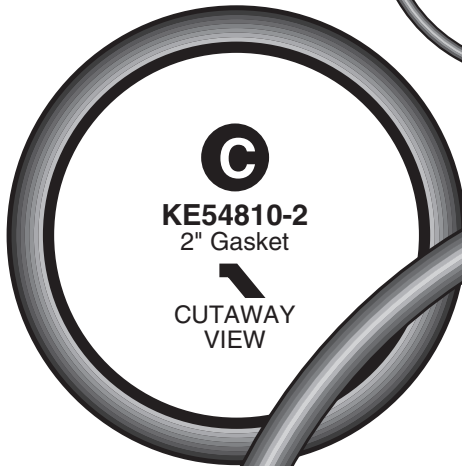
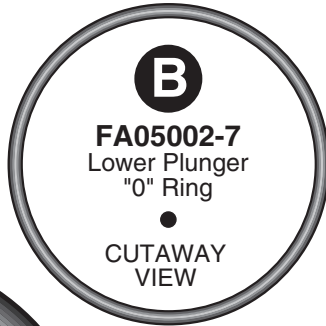
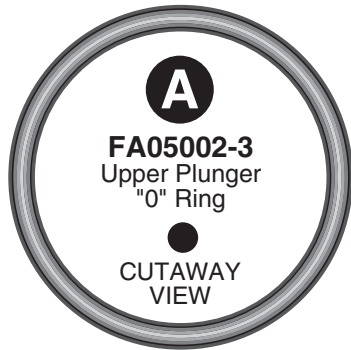

# PNEUMATIC SCHEMATIC

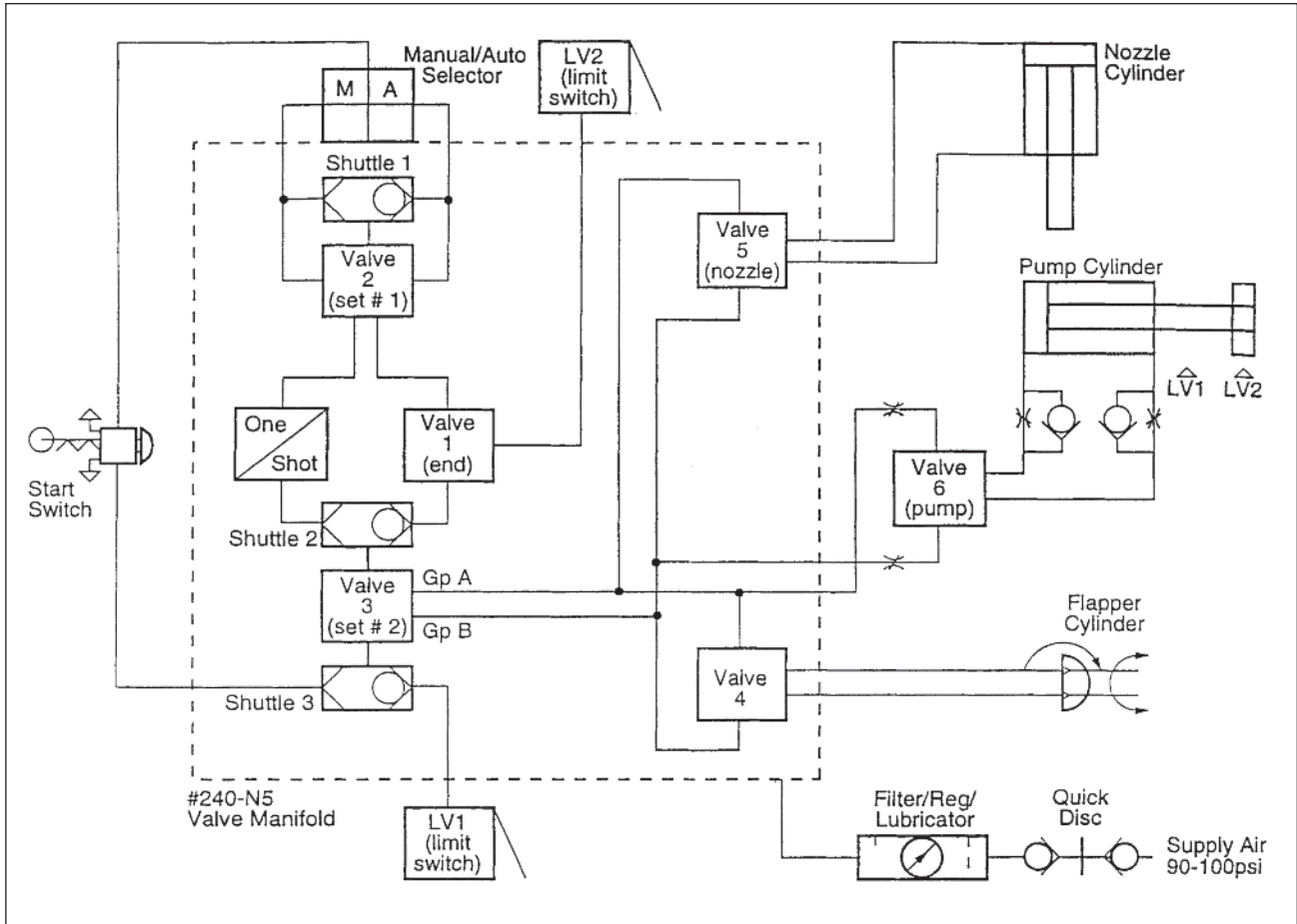

# AIR PACKAGE

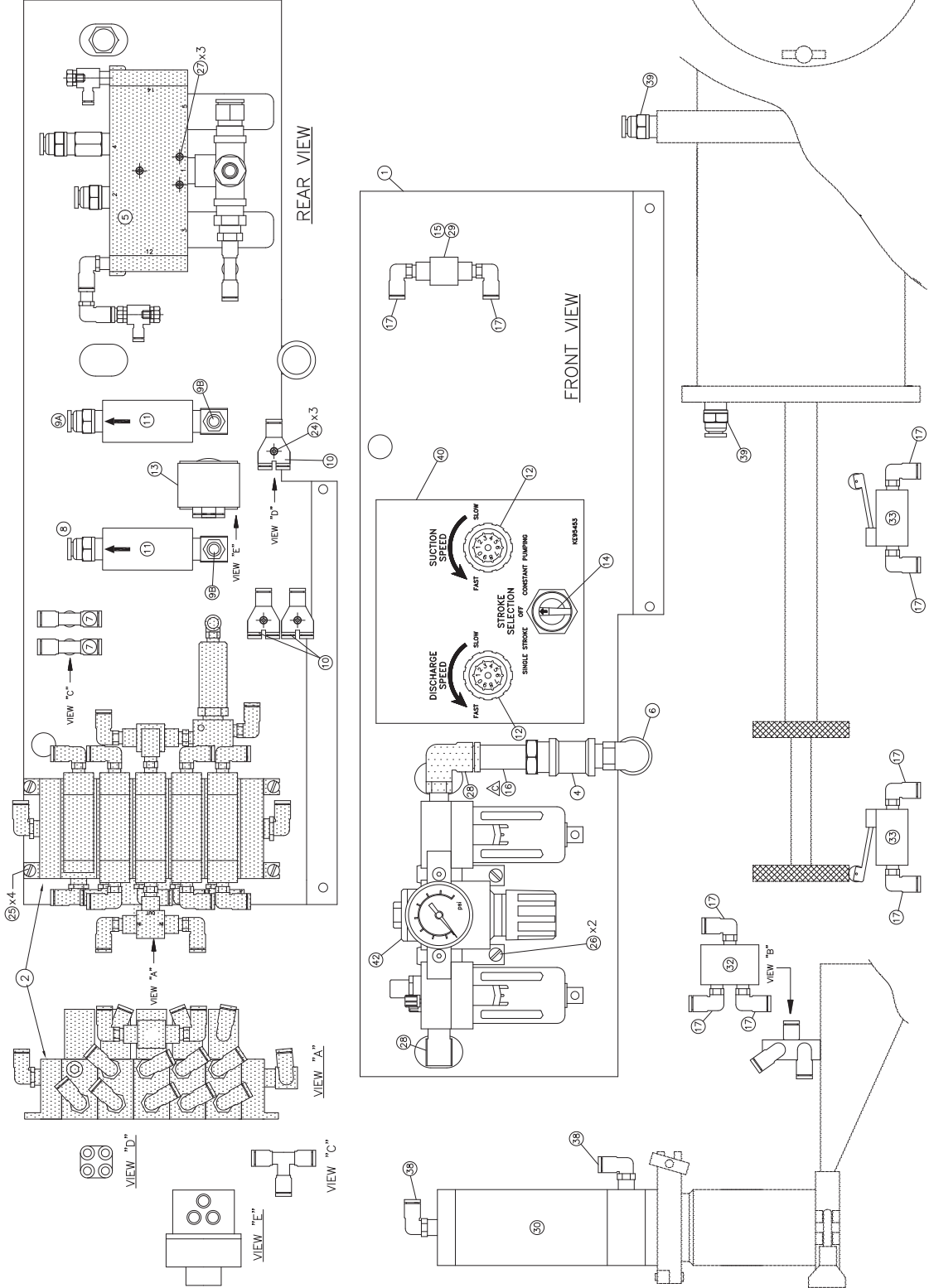

ITEM #	PARTS #	ITEMS LISTED BELOW ARE LOOSE PARTS	DESCRIPTION	MANUFACTURE #	QTY.
30	KE53270	AIR CYLINDER	4-D-3	1	
31	KE53014-1	ROTIARY ACTUATOR	41-P	1	
32	KE54287	AIR LIMIT SWITCH WITH ACTUATOR	31-P + 34-C	2	
33	KE54286	3/8" BULKHEAD FITTING	1495-C	2	
34	F105262	QUICK DISCONNECT BODY	DC-2103	1	
35	F105262-1	QUICK DISCONNECT PLUG	DCP-2144	1	
36	F105276	1/4 TUBE X 90° X 1/8 NPT ELBOW	6520-04-02	2	
37	F105277	1/4 TUBE X 90° X 1/4 NPT ELBOW	6520-04-04	2	
38	KE601381	1/2" TUBE X 3/4" STRAIGHT	6510-08-04	2	
39	KE601373	FLOW CONTROL LABEL	IN103-102-022	1	
40	KE601373	STRAIGHT TUBE FITTING 1/2" X 1/2"	IN109-532-020	2	
41	F105274	PUSH-IN ELBOW, 5/32 X 1/8		7	

ITEM #	PARTS #	DESCRIPTION	MANUFACTURE #	QTY.
17	F105274	PUSH-IN ELBOW, 5/32 X 1/8	IN109-532-020	2
18	KE54301	1/4" URETHANE CLEAR TUBE	UB 1/4-C	2
19	KE54689	3/8" URETHANE CLEAR TUBE	UB 3/8-C	2
20	KE54342-1	5/32 URETHANE BLACK TUBE	UB 0425-B	2
21	KE54342-1	5/32 URETHANE CLEAR TUBE	UB 0425-C	2
22	KE54301-1	1/4" URETHANE BLACK TUBE	UB 1/4-B	2
23	FA11058	6-32 X 7/8" LG. MACHINE SCREW		3
24	FA95091	HEX SOCKET SHOULDER SCREW 8-32 X 1 1/4		6
25	FA11145	10-32 X 1/2" LG. MACHINE SCREW		4
26	FA11256	1/4-20 X 1/2" LG. MACHINE SCREW		2
27	KE601396	90 DEGREE ELBOW	116C	2
28	KE601396	HEX NIPPLE 1/8" NPT	122-A	1
29	KE54281	3/8 AIR UNIT FRL	NAC3000-N03-3G	1

ITEM #	PARTS #	DESCRIPTION	MANUFACTURE #	QTY.
1	KE53042	PNEUMATIC COMPONENTS MOUNTING PLATE		1
2	KE01710-4	5 STATION VALVE MANIFOLD ASSEMBLY		1
3	KE601383	3-WAY LOCK OUT VALVE	IN530-022-022	1
4	KE01710-5	PUMP VALVE ASSEMBLY		1
5	KE5479	PUSH-IN ELBOW 1/2" X 3/8	IN109-102-022	2
6	KE5475	MALE RUN TEE 3/8 NPT X 1/4 TUBE	IN103-102-023	1
7	KE601374	1/2" X 1/2" STRAIGHT PUSH-ON HOSE CONNECTOR	IN103-102-023	1
8	KE601374	1/2" X 1/2" STRAIGHT PUSH-ON HOSE CONNECTOR	IN103-102-023	1
9	KE601378	ADAPTOR	PRG 1/4 - 5/32	2
10	KE55480	AIR MANIFOLD	104104-F04	2
11	KE601379	PUMP CYLINDER FLOW CONTROL	104094	2
12	KE54296	MOUNTING NUTS FOR PUMP CYLINDER FLOW CONTROL	2.304 MB CU	1
13	KE54297-1	SELECTOR VALVE (MAN - AUTO)	RM 413N	1
14	KE54298-1	SELECTOR KNOB	ST25	1
15	KE54288	SHUTTLE VALVE - HUMPHREY PART	113-C2	1
16	KE603776	3/8 X 2" BRASS NIPPLE		1

NOTE: ITEMS 34, 35, 36 AND 41 NOT SHOWN

# POINT TO POINT AIR TUBING CONNECTIONS

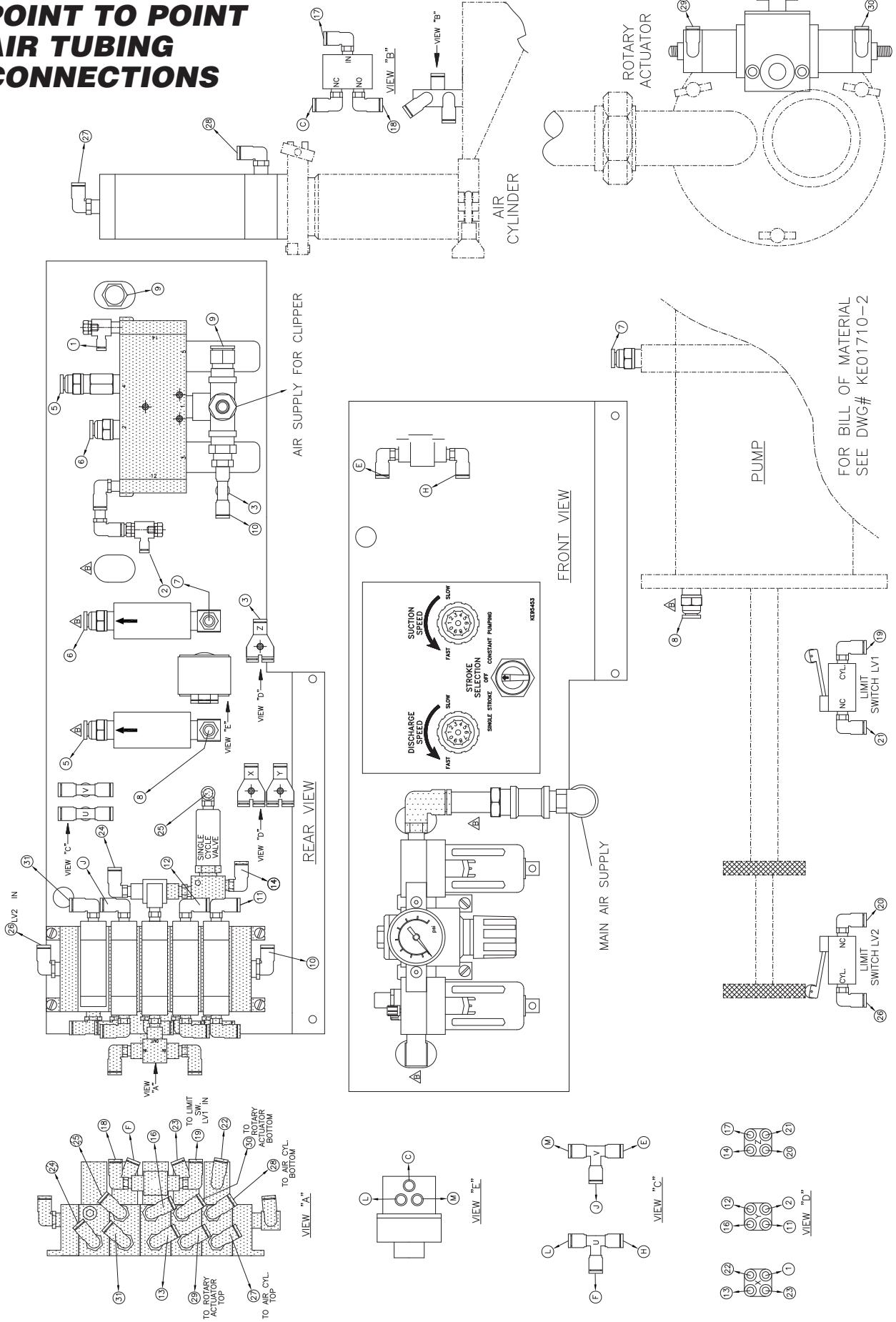

# PUMP VALVE ASSEMBLIES

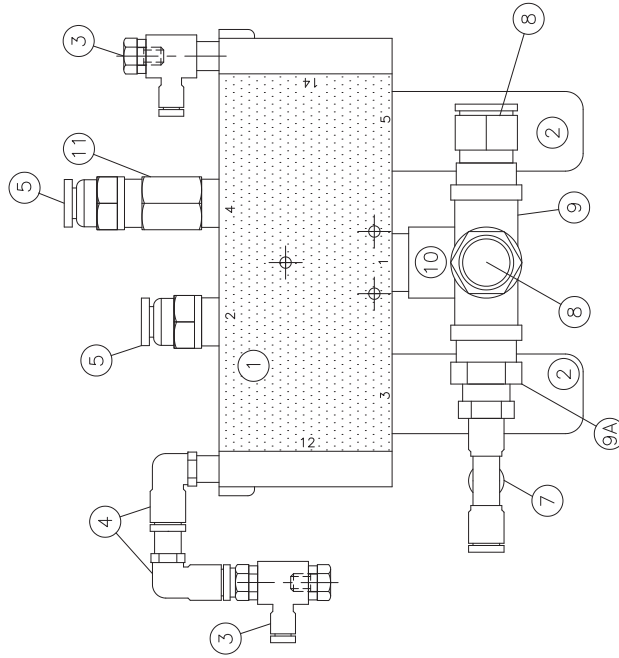

ITEM #	PARTS #	DESCRIPTION	MANUFACTURE #	QTY.
1	KE54291	PUMP VALVE	L23PP4520	1
2	KE54346	MUFFLER	SR03	2
3	FI05276	PUSH-IN FLOW CONTROL ELBOW 1/4 X 1/8	IN136C-532-020	2
4	KE55472	1/8" STREET ELBOW	116-A	2
5	KE601373	1/2" PUSH IN HOSE CONNECTOR	INW103-102-022	2
7	KE55475	MALE RUN TEE 3/8 NPTX 1/4 OD. TUBE	IN109-104-022	1
8	KE601374	PUSH IN STRAIGHT 1/2 X 1/2	INW103-102-023	2
9	KE601375	1/2" BRASS CROSS	102-D	1
9A	KE601376	1/2" X 3/8" BUSHING	110-DC	2
10	FI05282	3/8 FORGED 90° MALE ELBOW	99-C	1
11	KE601377	M/M STRAIGHT CONNECTOR	120-CC	1

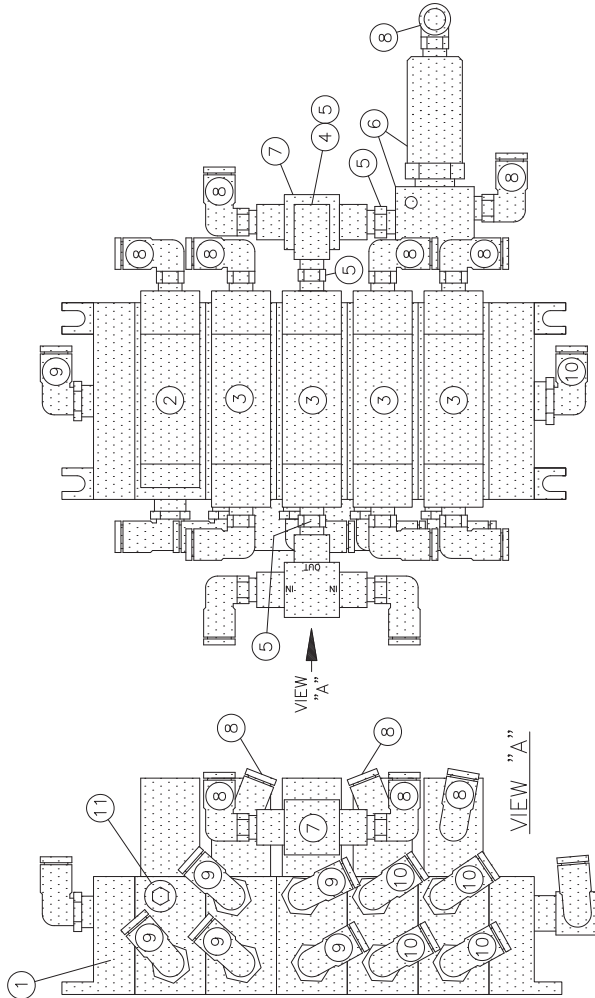

ITEM #	PARTS #	DESCRIPTION	MANUFACTURE #	QTY.
1	KE54343	5 STATION VALVE MANIFOLD	HC95001A	1
2	KE54289	VALVE #1 (CONTROL VALVE)	HA-240-4A	1
3	KE54290	VALVE #2,3,4,5 (SELECTOR1, SELECTOR2, FLAPPER, NOZZLE)	HA-240-4A2	4
4	KE55472	1/8" STREET ELBOW	116A	4
5	FI05271-2	1/8 BRASS HEX. NIPPLE	122-A	2
6	KE54292	ONE SHOT VALVE	31-P + 341-AR	1
7	KE54288	SHUTTLE VALVE	S-125	3
8	FI05274	PUSH-IN ELBOW, 5/32 X 1/8	IN109-532-020	12
9	FI05275	PUSH-IN ELBOW, 5/32 X 1/4	IN109-532-021	6
10	FI05277	PUSH-IN ELBOW, 1/4 X 1/4	IN109-104-021	5
11	KE53360	1/4 HEX. PLUG.	118-B	1

16	KE54345	3 WAY SPOOL VALVE	0669-10-18-MF	
17	FI05274	5/32" TUBE TO 1/8" NPT MALE PUSH-IN FITTING (ELBOW)	3109-04-11	22
18	FI05275	5/32" TUBE TO 1/4" NPT MALE PUSH-IN FITTING (ELBOW)	3109-04-14	7
19	FI05276	1/4" TUBE TO 1/8" NPT MALE PUSH-IN FITTING (ELBOW)	3109-56-11	4
20	FI05277	1/4" TUBE TO 1/4" NPT MALE PUSH-IN FITTING (ELBOW)	3109-56-14	6
21	FI05279	5/32" TUBE TO 1/4" NPT MALE PUSH-IN FITTING (STRAIGHT)	3175-04-13	3
22	FI05280	5/32 x 5/32 x 5/32 TUBE PUSH-IN FITTING (TEE)	3104-04-00	3
23	KE53359	1/8" BRASS HEX PLUG	118-A	
28	KE53351	1/8" EXTRUDED 90° BRASS ELBOW	100-A	1
29	FI05030	3/8" EXTRUDED 90° BRASS STREET ELBOW	116-C	5
30	FI05282	1/2" EXTRUDED 90° BRASS STREET ELBOW	116-D	3
31	FI05270	1/4" EXTRUDED MALE BRANCH BRASS TEE	106-B	1

# SPARE PARTS LIST

<i>ITEM ON.</i>	<i>DESCRIPTION</i>	<b>QTY. DOMESTIC</b>	<b>QTY. OVERSEAS</b>
<b><u>Consumables</u></b>			
KE54810-3	Gasket, 3", Food Hose	10	50
KE54810-2	Gasket, 2", Piping Assembly	10	50
KE53056	Spring, Pump Head	2	10
KE54167	Food Grade Grease	1	10
FA05002-24	"O" Ring, Flapper Valve	4	20
FA05002-3	"O" Ring, Upper Plunger Seal	10	50
FA05002-2	"O" Ring, Pump Head	10	50
FA05002-7	"O" Ring, Lower Plunger Seal	10	50
FA05002-26	"O" Ring, Product Piston Head	10	50
<b><u>Spare Parts</u></b>			
FA05002-6	"O" Ring, Rear Seal	1	2
FA05002-1	"O" Ring, Front Seal	1	2
KE01302	Lug Nut	1	2
KE54278	Removable Panel Stop	1	2
KE53266	Spring, Label Dispenser	1	2
KE53014-1	Rotary Actuator	---	1
KE01712	Air Cylinder, Discharge Head	---	1
KE01518	Hose for Clipper	---	1
KE01750	Hose for MFS to Kettle	---	1
KE54286	Air Limit Switch	---	1
KE54295	Air Flow Control	---	1
SE00090	Control Valve Assembly	---	1
SE00091	Pump Valve Assembly	---	1

## OPTIONAL THERMO ASSURANCE PACKAGE PARTS

<b><u>Consumables</u></b>			
FA05002-28	"O" Ring	5	20
<b><u>Spare Parts</u></b>			
KE53206	RTD Sensor	1	1
KE53200	Bulb	1	2
KE53203	Clipper Lockout Valve	---	1