



Operators Manual

Installation, Operation & Service

Gas 25 Gallon Kettle

MODELS:

KGL-25

KGL-25-T



Enodis

1333 East 179th St., Cleveland, Ohio, U.S.A. 44110

Phone: (216) 481-4900 Fax: (216) 481-3782
Visit our web site at www.clevelandrange.com

FOR THE USER

IMPORTANT!
**PRIOR TO REMOVING ANY FITTINGS ENSURE KETTLE
IS AT ROOM TEMPERATURE AND
PRESSURE GAUGE IS SHOWING ZERO OR LESS PRESSURE.**

FOR YOUR SAFETY

DO NOT STORE OR USE
GASOLINE OR ANY OTHER
FLAMMABLE LIQUIDS AND
VAPOURS IN THE VICINITY
OF THIS OR ANY OTHER
APPLIANCE.

WARNING: Improper installation,
adjustment, alteration, service or
maintenance can cause property
damage, injury or death. Read the
installation and operating
instructions thoroughly before
installing or servicing this
equipment.

IMPORTANT

POST IN A PROMINENT LOCATION, INSTRUCTIONS TO BE FOLLOWED IN THE EVENT
THE USER SMELLS GAS. THIS INFORMATION SHALL BE OBTAINED BY CONSULTING
YOUR LOCAL GAS SUPPLIER.

KEEP APPLIANCE AREA FREE AND CLEAR FROM COMBUSTIBLES.

DO NOT OBSTRUCT THE FLOW OF COMBUSTION AND VENTILATION AIR.

ALL SERVICE MUST BE PERFORMED BY A QUALIFIED CLEVELAND RANGE
TECHNICIAN.

RETAIN THIS MANUAL FOR YOUR REFERENCE.

For your safety

DANGER

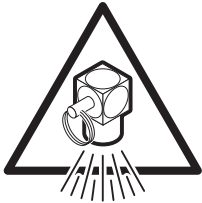

Keep clear of pressure relief discharge.



Keep hands away from moving parts and pinch points.

IMPORTANT



Inspect unit daily for proper operation.

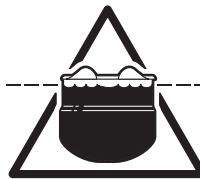

Do not fill kettle above recommended level marked on outside of kettle.

CAUTION



Surfaces may be extremely hot! Use protective equipment.



Wear protective equipment when discharging hot product.



Do not lean on or place objects on kettle lip.

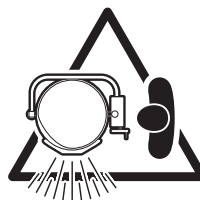

Stand clear of product discharge path when discharging hot product.

SERVICING

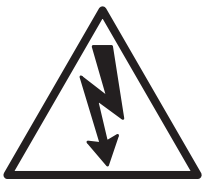

Shut off power at main fuse disconnect prior to servicing.



Ensure kettle is at room temperature and pressure gauge is showing zero or less prior to removing any fittings.

GAS APPLIANCES

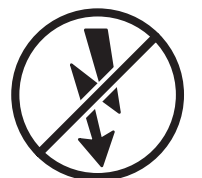

Do not attempt to operate this appliance during a power failure.



Keep appliance and area free and clear of combustibles.

INSTALLATION

INSPECTION

Before unpacking visually inspect the unit for evidence of damage during shipping.

If damage is noticed, do not unpack the unit, follow shipping damage instructions.

SHIPPING DAMAGE INSTRUCTIONS

If shipping damage to the unit is discovered or suspected, observe the following guidelines in preparing a shipping damage claim.

1. Write down a description of the damage or the reason for suspecting damage as soon as it is discovered. This will help in filling out the claim forms later.
2. As soon as damage is discovered or suspected, notify the carrier that delivered the shipment.
3. Arrange for the carrier's representative to examine the damage.
4. Fill out all carrier claims forms and have the examining carrier sign and date each form.

GENERAL

Installation of the kettle must be accomplished by qualified installation personnel working to all applicable local and national codes. Improper installation of product could cause injury or damage.

This equipment is built to comply with applicable standards for manufacturers. Included among those approval agencies are: UL, A.G.A., NSF, ASME/N.Bd., CSA, CGA, ETL, and others. Many local codes exist, and it is the responsibility of the owner/installer to comply with these codes.

Observe all clearance requirements to provide proper make-up air flow. Do not obstruct the flow of combustion and ventilation air. Check rating plate to ensure that kettle has been equipped to operate with the type of gas available at the installation.

CLEARANCE REQUIREMENTS

This unit must be installed in accordance with the clearances shown on the rating label which is adhered to the unit.

FOR YOUR SAFETY. Keep the appliance area free and clear of combustible materials.

INSTALLATION

Note: For clearance requirements, suggested drain location and assembly details refer to SPECIFICATION DRAWING.

1. Position the unit in its permanent location, and level the unit by turning the adjustable feet.

2. Once positioned and leveled, permanently secure the unit's flanged feet to the floor using 5/16" lag bolts and floor anchors

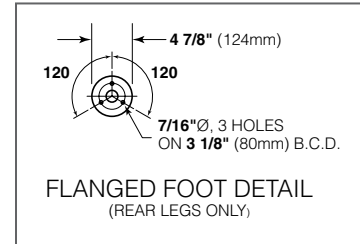

(supplied by the installer). Three bolts are required to secure each of the flanged feet.

3. Seal joints of flanged feet with a silicone sealant.

GAS

ENSURE THE GAS SUPPLY MATCHES THE KETTLE'S REQUIREMENTS AS STATED ON THE RATING PLATE.

It is recommended that a sediment trap (drip leg) be installed in the gas supply line. If the gas pressure exceeds 14" water column, a pressure regulator must be installed, to provide a maximum of 14" water column gas pressure to the gas control valve.

Connect the gas line to the manual valve located at the rear of the control box.

Installation must be in accordance with local codes and/or the National Fuel Gas Code ANSI Z223.1 Latest Edition (USA) or the latest Installation Codes for Gas Burning Appliances and Equipment CAN/ CGA B149.1 and CAN/ CGA B149.2 (Canada). Use a gas pipe joint compound which is resistant to L.P. gas. Test all pipe joints for leaks with soap and water solution. Ensure that the gas pressure regulator is set for the manifold pressure indicated on the gas rating plate.

The appliance and its individual shut-off valve must be disconnected from the gas supply piping system during any pressure testing of that system at test pressures in excess of 1/2 psi (3.45 kPa). The appliance must be isolated from the gas supply piping system by closing its individual manual shut-off valve during any pressure testing of the gas supply piping system at test pressures equal to or less than 1/2 psi (3.45 kPa).

ELECTRICAL

ENSURE THE ELECTRICAL SUPPLY MATCHES THE KETTLE'S REQUIREMENTS AS STATED ON THE RATING LABEL.

A cord and plug are supplied with the unit. Simply plug the unit into any grounded outlet rated for a minimum of 10 amps.

WARNING: Electrical Grounding Instructions.

This unit is equipped with a three-prong (grounding) plug for your protection against shock hazard and should be plugged directly into a properly grounded three-prong receptacle. Do not cut or remove the grounding prong from this plug. Standard supply voltage is 115 volts A.C., however, optional A.C. voltages can be supplied on special order. A separate fused disconnect switch must be supplied and installed in the high voltage electrical supply line. The kettle when installed, must be electrically installed and grounded in accordance with local codes, or in the absence of local codes, with National Electrical Code, ANSI/NFPA 70-1990 (USA) or the Canadian Electrical Code, CSA C22.2, Part 1 (Canada).

VENTILATION

Gas fired kettles are only to be installed under a ventilation hood in a room which has provisions for adequate make up air. Further information can be obtained by referring to the U.S.A. National Fire Protection Associations NFPA96 regulations. These standards have also been adopted by the National Building Code in Canada.

WATER

The sealed jacket of the gas-fired kettle is precharged with the correct amount of a water-based formula, and therefore, no water connection is required to the kettle jacket. The kettle can be equipped with optional hot and cold water taps, the taps require 1/2" copper tubing as supply lines.

INSTALLATION CHECKS

Although the kettle has been thoroughly tested before leaving the factory, the installer is responsible for ensuring the proper operation of kettle once installed.

DO NOT ATTEMPT TO OPERATE THIS APPLIANCE DURING A POWER FAILURE.

KEEP APPLIANCE AND AREA FREE AND CLEAR OF COMBUSTIBLES.

- 1.** Before turning the kettle on, read the vacuum/pressure gauge. The gauge's needle should be in the green zone. If the needle is in the "VENT AIR" zone, follow air venting procedure.
- 2.** Supply power to the kettle by placing the fused disconnect switch to the "ON" position.
- 3.** Unit has been thoroughly checked for gas leaks at the factory however the installer should check all connections using soap bubble or gas detector for any leaks which may have resulted from shipping or installation.
- 4.** Turn on main gas supply to unit. Open the kettle's shut-off valve (located at back of console).
- 5.** Turn the temperature control knob to "**1**" (Min.). The green LED light should remain lit, indicating the burner is lit, until the set temperature is reached. Then the green light will cycle on and off, indicating the burner is cycling on and off to maintain temperature.
- 6.** Tilt the kettle forward. After a few seconds the red "LOW WATER" light should be lit when the kettle is in a tilted position. This light indicates that the burner has automatically been shut off by the kettle's safety circuit. This is a normal condition when the kettle is in a tilted position.
- 7.** Raise the kettle to the upright position. The red "LOW WATER" light should go out when the kettle is upright.
- 8.** Turn the temperature control knob to "**10**" (Max.) and allow the kettle to preheat. The green light should remain on until the set temperature is reached. Then the green light will cycle ON and OFF, indicating the burner is cycling ON and OFF to maintain temperature.

CLEANING

After installation the kettle must be thoroughly cleaned and sanitized prior to cooking.

OPERATING INSTRUCTIONS



General Parts Drawing

ITEM #	DESCRIPTION	FUNCTION
1.	Tilt Wheel (tilting models only)	Used for tilting the kettle.
2.	Vacuum/Pressure Gauge	Indicate steam pressure in PSI inside steam jacket as well as vacuum in inches of mercury.
3.	Pressure Relief Valve	This valve is used to vent the kettle and in the unlikely event there is an excess steam build-up in the jacket, this valve opens automatically to relieve this pressure.
4.	Low Water Indicator Light (Red)	When lit, indicates that the kettle is low on water and will not operate in this condition. This will also light when the kettle is tilted.
5.	On-Off Switch/ Solid State Temperature Control	Turns kettle ON/OFF and allows the operator to adjust the kettle temperature in increments from 1 (Min.) to 10 (Max.).
6.	Heat Indicator Light (Green)	When lit, indicates that the kettle's burner is on. Cycles ON-OFF with burner.
7.	Water Level Sight Glass	Displays water level in steam jacket.
8.	Ignition Failure Indicator Light (Amber)	Indicates failure of heating system to ignite.
9.	Tangent Draw-Off Valve	Used for draining product or wash water from kettle. It is supplied as standard equipment on stationary kettles and is optional on tilting kettles.

OPERATING THE KETTLE

DO NOT ATTEMPT TO OPERATE THIS APPLIANCE DURING A POWER FAILURE.

KEEP APPLIANCE AND AREA FREE AND CLEAR OF COMBUSTIBLES.

DO NOT LEAN ON OR PLACE OBJECTS ON KETTLE LIP. SERIOUS INJURY COULD RESULT IF KETTLE TIPPED OVER, SPILLING HOT CONTENTS.

1. Before turning kettle on, read the Vacuum/Pressure Gauge (2). The gauges needle should be in the green zone. If the needle is in the "VENT AIR" zone, refer to the Kettle Venting Instructions. Any air that may be present will increase cooking times. Once heated, the kettle's normal maximum operating pressure is approximately 10-12 psi while cooking a water base product.
2. Ensure that the electrical service to the kettle is turned on at the fused disconnect switch.

Temperature Control Setting	Approximate Product Temperature	
	°F	°C
MIN.	120	49
1.	130	54
2.	145	63
3.	160	71
4.	170	77
5.	185	85
6.	195	91
7.	210	99
8.	230	110
9.	245	118
MAX.	265	130

NOTE: Certain combinations of ingredients will result in temperature variations

Temperature Range Chart

3. Preheat the kettle by turning the ON/OFF Switch/Solid State Temperature Control (5) to the desired temperature setting (see above, TEMPERATURE RANGE CHART). The Heat Indicator Light (Green) (6) will remain lit, indicating the burner is on, until the temperature setting is reached. When the green light goes off, the burners are off, and preheating is complete.

NOTE: When cooking egg and milk products, the kettle should not be preheated, as products of this nature adhere to hot cooking surfaces. These types of food should be placed in the kettle before heating is begun.

4. Place food product into the kettle. The Heat Indicator Light (Green) (6) will cycle on and off indicating the burners are cycling on and off to maintain the set temperature.

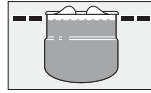

NOTE: Do not fill kettle above recommended level marked on outside of kettle.

NOTE: The Low Water Indicator Light (Red) (4) should not be lit when kettle is in upright position during kettle operation. This light indicates that the burners have been automatically shut off by the kettle's safety circuit. It is, however, normal for the red light to come on when the kettle is in a tilted position.

5. When cooking is completed turn ON/OFF Switch/Solid State Temperature Control (5) to the "OFF" position.

NOTE: A five minute complete shut-of period is required before relighting.

6. Pour the contents of the kettle into an appropriate container by tilting the kettle forward. Care should be taken to pour slowly enough to avoid splashing off the product.

NOTE: As with cleaning food soil from any cookware, an important part of kettle cleaning is to prevent food from drying on. For this reason, cleaning should be completed immediately after cooked foods are removed.

APPROXIMATE BOILING TIMES

The accompanying chart shows approximate times required for electric kettles of various capacities to boil water. The ON/OFF Switch/Solid State Temperature Control (5) must be set at "10" (Max.) throughout the heat-up period. Water will boil about 1/3 faster if the kettle is filled only to the outer steam jacket's welded seam resulting in a kettle filled to 2/3 capacity.

Kettle Capacity	Minutes
25 gallon	37

Approximate Boiling Times





CLEANING INSTRUCTIONS



CARE AND CLEANING

Cooking equipment must be cleaned regularly to maintain its fast, efficient cooking performance and to ensure its continued safe, reliable operation. The best time to clean is shortly after each use (allow unit to cool to a safe temperature).

WARNINGS

- ⇒  Do not use detergents or cleansers that are chloride based or contain quaternary salt.
Chloride Cleaners
- ⇒  Do not use a metal bristle brush or scraper.
Wire Brush &
- ⇒  Steel wool should never be used for cleaning the stainless steel.
Steel Pads
- ⇒  Unit should never be cleaned with a high pressure spray hose.
High Pressure Spray Hose
- ⇒  Do not leave water sitting in unit when not in use.
Stagnant Water

CLEANING INSTRUCTIONS

1. Turn unit off.
2. Remove drain screen (if applicable). Thoroughly wash and rinse the screen either in a sink or a dishwasher.
3. Prepare a warm water and mild detergent solution in the unit.
4. Remove food soil using a nylon brush.
5. Loosen food which is stuck by allowing it to soak at a low temperature setting.
6. Drain unit.
7. Rinse interior thoroughly.
8. If the unit is equipped with a **Tangent Draw-Off Valve**, clean as follows:
 - a) Disassemble the draw-off valve first by turning the valve knob counter-clockwise, then turning the large hex nut counter-clockwise until the valve stem is free of the valve body.
 - b) In a sink, wash and rinse the inside of the valve body using a nylon brush.
 - c) Use a nylon brush to clean tangent draw-off tube.
 - d) Rinse with fresh water.
 - e) Reassemble the draw-off valve by reversing the procedure for disassembly. The valve's hex nut should be hand tight only.
9. If the unit is equipped with a **Butterfly Valve**, clean as follows:
 - a) Place valve in open position.
 - b) Wash using a warm water and mild detergent solution.
 - c) Remove food deposits using a nylon brush.
 - d) Rinse with fresh water.
 - e) Leave valve open when unit is not in use.
10. Using mild soapy water and a damp sponge, wash the exterior, rinse, and dry.

NOTES

- ⇒ For more difficult cleaning applications one of the following can be used: alcohol, baking soda, vinegar, or a solution of ammonia in water.
- ⇒ Leave the cover off when the kettle is not in use.
- ⇒ For more detailed instructions refer to the Nafem Stainless Steel Equipment Care and Cleaning manual (supplied with unit).

STAINLESS STEEL EQUIPMENT CARE AND CLEANING

(Supplied courtesy of Nafem. For more information visit their web site at www.nafem.org)

Contrary to popular belief, stainless steels ARE susceptible to rusting.

Corrosion on metals is everywhere. It is recognized quickly on iron and steel as unsightly yellow/orange rust. Such metals are called "active" because they actively corrode in a natural environment when their atoms combine with oxygen to form rust.

Stainless steels are passive metals because they contain other metals, like chromium, nickel and manganese that stabilize the atoms. 400 series stainless steels are called ferritic, contain chromium, and are magnetic; 300 series stainless steels are called austenitic, contain chromium and nickel; and 200 series stainless, also austenitic, contains manganese, nitrogen and carbon. Austenitic types of stainless are not magnetic, and generally provide greater resistance to corrosion than ferritic types.

With 12-30 percent chromium, an invisible passive film covers the steel's surface acting as a shield against corrosion. As long as the film is intact and not broken or contaminated, the metal is passive and stain-less. If the passive film of stainless steel has been broken, equipment starts to corrode. At its end, it rusts.

Enemies of Stainless Steel

There are three basic things which can break down stainless steel's passivity layer and allow corrosion to occur.

1. Mechanical abrasion
2. Deposits and water
3. Chlorides

Mechanical abrasion means those things that will scratch a steel surface. Steel pads, wire brushes and scrapers are prime examples.

Water comes out of the faucet in varying degrees of hardness. Depending on what part of the country you live in, you may have hard or soft water. Hard water may leave spots, and when heated leave deposits behind that if left to sit, will break down the passive layer and rust stainless steel. Other deposits from food preparation and service must be properly removed.

Chlorides are found nearly everywhere. They are in water, food and table salt. One of the worst chloride perpetrators can come from household and industrial cleaners.

So what does all this mean? Don't Despair!

Here are a few steps that can help prevent stainless steel rust.

1. Use the proper tools.

When cleaning stainless steel products, use non-abrasive tools. Soft cloths and plastic scouring pads will not harm steel's passive layer. Stainless steel pads also can be used but the scrubbing motion must be in the direction of the manufacturers' polishing marks.

2. Clean with the polish lines.

Some stainless steel comes with visible polishing lines or "grain." When visible lines are present, always scrub in a motion parallel to the lines. When the grain cannot be seen, play it safe and use a soft cloth or plastic scouring pad.

3. Use alkaline, alkaline chlorinated or non-chloride containing cleaners.

While many traditional cleaners are loaded with chlorides, the industry is providing an ever-increasing choice of non-chloride cleaners. If you are not sure of chloride content in the cleaner used, contact your cleaner supplier. If your present cleaner contains chlorides, ask your supplier if they have an alternative. Avoid cleaners containing quaternary salts; it also can attack stainless steel and cause pitting and rusting.

4. Treat your water.

Though this is not always practical, softening hard water can do much to reduce deposits. There are certain filters that can be installed to remove distasteful and corrosive elements. To insure proper water treatment, call a treatment specialist.

5. Keep your food equipment clean.

Use alkaline, alkaline chlorinated or non-chloride cleaners at recommended strength. Clean frequently to avoid build-up of hard, stubborn stains. If you boil water in stainless steel equipment, remember the single most likely cause of damage is chlorides in the water. Heating cleaners that contain chlorides have a similar effect.

6. Rinse, rinse, rinse.

If chlorinated cleaners are used, rinse and wipe equipment and supplies dry immediately. The sooner you wipe off standing water, especially when it contains cleaning agents, the better. After wiping equipment down, allow it to air dry; oxygen helps maintain the stainless steel's passivity film.

7. Never use hydrochloric acid (muriatic acid) on stainless steel.

8. Regularly restore/passivate stainless steel.

Recommended cleaners for specific situations

Job	Cleaning Agent	Comments
Routine cleaning	Soap, ammonia, detergent, Medallion	Apply with cloth or sponge
Fingerprints & smears	Arcal 20, Lac-O-Nu Ecoshine	Provides barrier film
Stubborn stains & discoloration	Cameo, Talc, Zud, First Impression	Rub in direction of polish lines
Grease & fatty acids, blood, burnt-on-foods	Easy-off, De-Grease It Oven Aid	Excellent removal on all finishes
Grease & oil	Any good commercial detergent	Apply with sponge or cloth
Restoration/Passivation	Benefit, Super Sheen	

Review

1. Stainless steels rust when passivity (film-shield) breaks down as a result of scrapes, scratches, deposits and chlorides.
2. Stainless steel rust starts with pits and cracks.
3. Use the proper tools. Do not use steel pads, wire brushes or scrapers to clean stainless steel.
4. Use non-chlorinated cleaners at recommended concentrations. Use only chloride-free cleaners.
5. Soften your water. Use filters and softeners whenever possible.
6. Wipe off cleaning agent(s) and standing water as soon as possible. Prolonged contact causes eventual problems.

To learn more about chloride-stress corrosion and how to prevent it, contact the equipment manufacturer or cleaning materials supplier.

Developed by Packer Engineering, Naperville, Ill., an independent testing laboratory.

SERVICE PARTS

WARRANTY

Our Company supports a worldwide network of Maintenance and Repair Centers. Contact your nearest Maintenance and Repair Centre for replacement parts, service, or information regarding the proper maintenance and repair of your cooking equipment

In order to preserve the various agency safety certification (UL, NSF, ASME/Ntl. Bd., etc.), only factory-supplied replacement parts should be used. The use of other than factory supplied replacement parts will void warranty.

FAUCET ASSEMBLY (optional)

ITEM NO.	PART NO.	DESCRIPTION	QTY.
1.		<u>3/4" SPOUT</u>	
	KE50825-7	FOR STATIONARY KETTLES	1
	KE50825-2	FOR TILTING KETTLES	1
2.	FA95022	RETAINING RING	1
3.	FA05002-19	"O" RING	1
4.	KE51736	LONG FAUCET NUT	1
5.	SE50020	HOT WATER STEM ASSEMBLY	1
		(DOUBLE PANTRY ONLY)	
6.	SE50021	COLD WATER STEM ASSEMBLY	1
7.	KE51401	SINGLE PANTRY BODY	1
		(C/W ITEM NO. 6)	
8.	KE50335	ADAPTER WASHER	1
		(SINGLE PANTRY ONLY)	
9.	KE51403	DOUBLE PANTRY BODY	1
		(C/W ITEM NO. 5&6)	
10.	SK00395-1	FAUCET MOUNTING BRACKET	1
11.	FA11258	HEX CAP SCREW	2
12.	FA30505-1	WASHER	2
13.	FA21008	HEX NUT	2
14.	SE50447	WASHER HORSESHOE	1

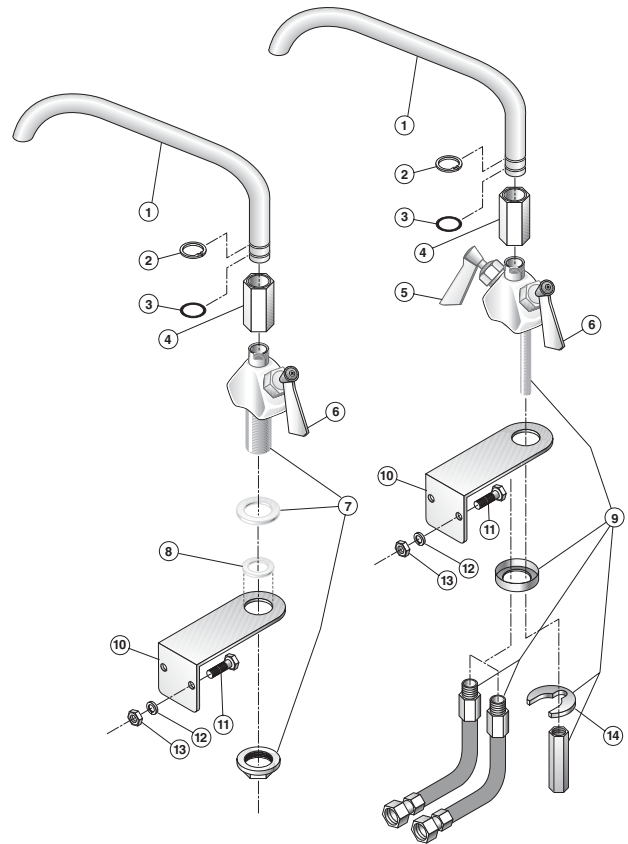

COMPONENT MOUNTING PLATES

STATIONARY MODELS

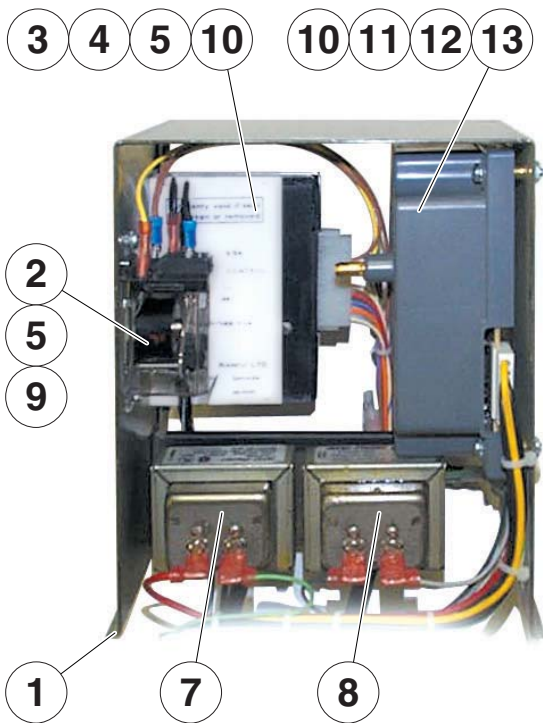

TILTING MODELS

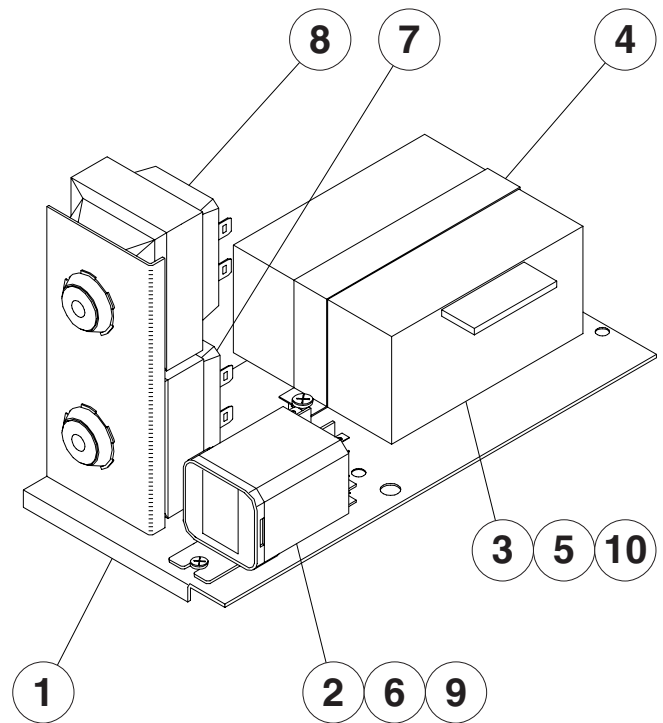

ITEM NO.	PART NO.	DESCRIPTION	QTY.
1.	KE01927-1	COMPONENT MOUNTING PLATE (STATIONARY MODELS)	1
	KE01927	COMPONENT MOUNTING PLATE (TILTING MODELS)	1
2.	KE50753-7	RELAY	1
3.	KE00458-1	SSK CONTROL BOX	1
4.	KE50303	ELECTRONIC BOX HOLDER (STATIONARY MODELS)	1
	KE52548	ELECTRONIC BOX HOLDER (TILTING MODELS)	1
5.	FA11089	SCREWS	2
6.	FA11052	SCREWS	2
9.	FA32004	TOOTH LOCKWASHER	2
10.	FA32005	TOOTH LOCKWASHER	6
11.*	KE53469-2	IGNITION CONTROL	1
	KE54308-3	HIGH VOLTAGE LEAD ASSEMBLY	1
12.*	FA10245	SCREW (8-32)	4
13.*	FA20004	HEX NUT	4
FOR 120V OPTION			
7.	KE53838-20	TRANSFORMER	1
8.	KE53838-27	TRANSFORMER	1
FOR 240V OPTION			
7.	KE53838-18	TRANSFORMER	1
8.	KE53838-21	TRANSFORMER	1

* FOR TILTING MODELS SEE "GENERAL ASSEMBLY - TILTING MODELS"

BURNER ASSEMBLY

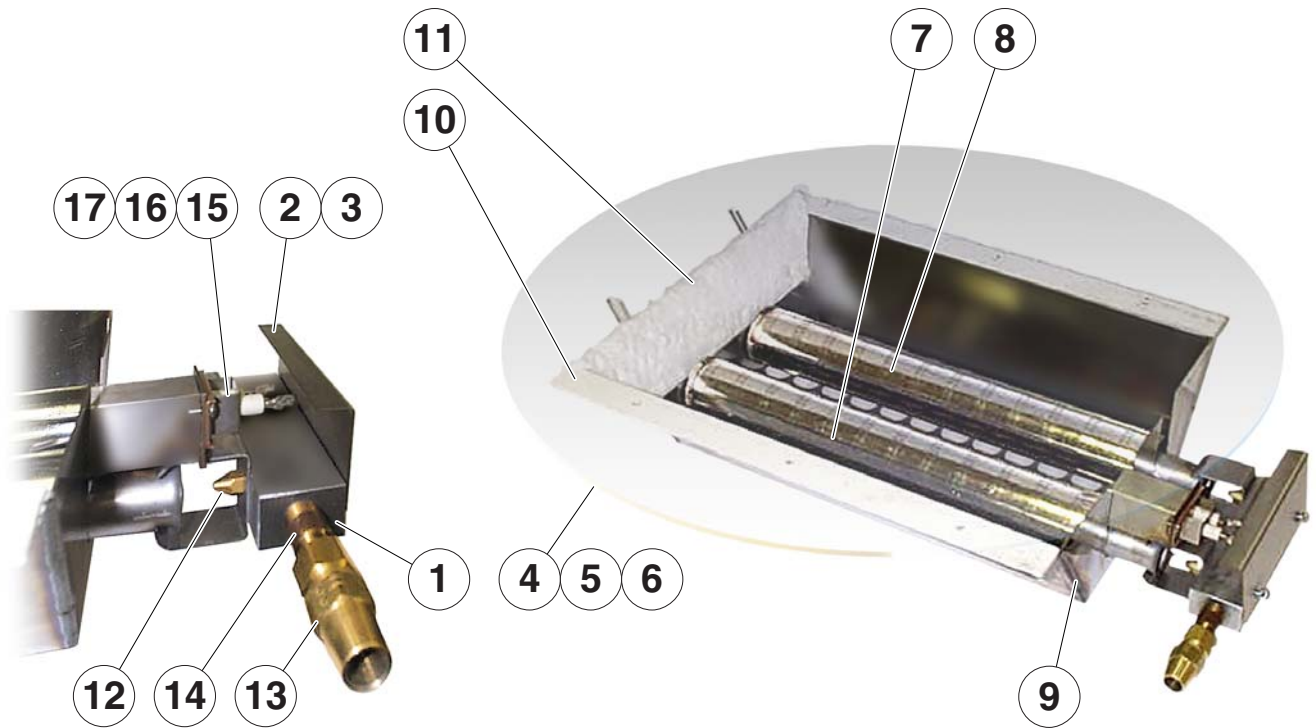

ITEM NO.	PART NO.	DESCRIPTION	QTY.
1.	KE54897-1	MANIFOLD	1
2.	KE54890-1	IGNITION GUARD	1
3.	FA11144	SCREW	2
4.	KE54881-1	BOTTOM COVER	1
5.	KE54894-1	HOLDER, BOTTOM COVER	1
6.	KE54895-3	INSULATION ON TOP OF COVER	1
7.	KE01500-2	BURNER ASSEMBLY	1
8.	KE01500-4	BURNER WITHOUT IGNITOR	1
9.	KE02195-1	BURNER PAN ASSEMBLY	1
10.	KE54895-2	INSULATION BETWEEN BOTTOM COVER & BURNER ASSEMBLY	2
11.	KE54895-4	INSULATION	1
12.	KE53406-21	GAS ORIFICE, NATURAL GAS	2
	KE53406-18	GAS ORIFICE, LP.	2
13.	FI05134-1	COMPRESSION FITTING	2
14.	FI00565-6	NIPPLE 3/8 NPT	1
15.	KE53437-1	IGNITOR	1
16.	FA11145	SCREW	2
17.	KE54775	IGNITOR POSITION HOLDING BRACKET	1

TANGENT DRAW-OFF VALVE

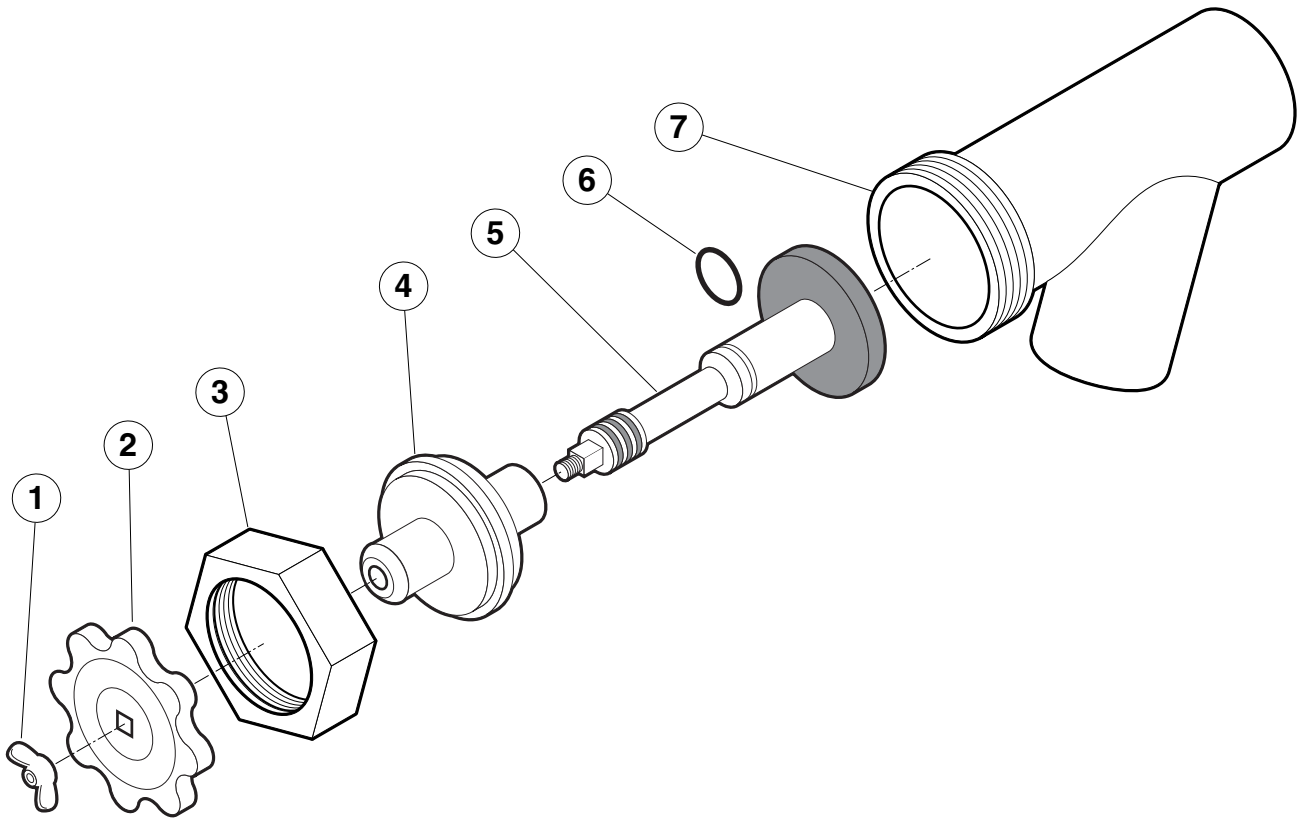

ITEM NO.	PART NO.	DESCRIPTION	QTY.
1. - 7.	KE50973	2" DRAW-OFF ASSEMBLY	1
	KE50972-B	3" DRAW-OFF ASSEMBLY	1
1.	FA95049	WING NUT, TD-2	1
	FA21050	ACCORN NUT, TD-2	1
	FA21501-1	ACCORN NUT, TD-3	1
2.	KE52755	KNOB, TD-2	1
	SE50018	KNOB, TD-3	1
3.	FI05180-1	HEX NUT, TD-2	1
	FI05180-2	HEX NUT, TD-3	1
4.	KE52753	RETAINER, TD-2	1
	SE50013	RETAINER, TD-3	1
5.	KE52752	PISTON, TD-2	1
	SE50010	PISTON, TD-3	1
6.	FA05002-24	"O" RING, TD-2	1
	FA05002-38	"O" RING, TD-3	1
7.	KE50972-B	VALVE BODY, TD-2	1
	KE50973	VALVE BODY, TD-3	1

GENERAL ASSEMBLY - STATIONARY MODELS (pg. 1 of 2)

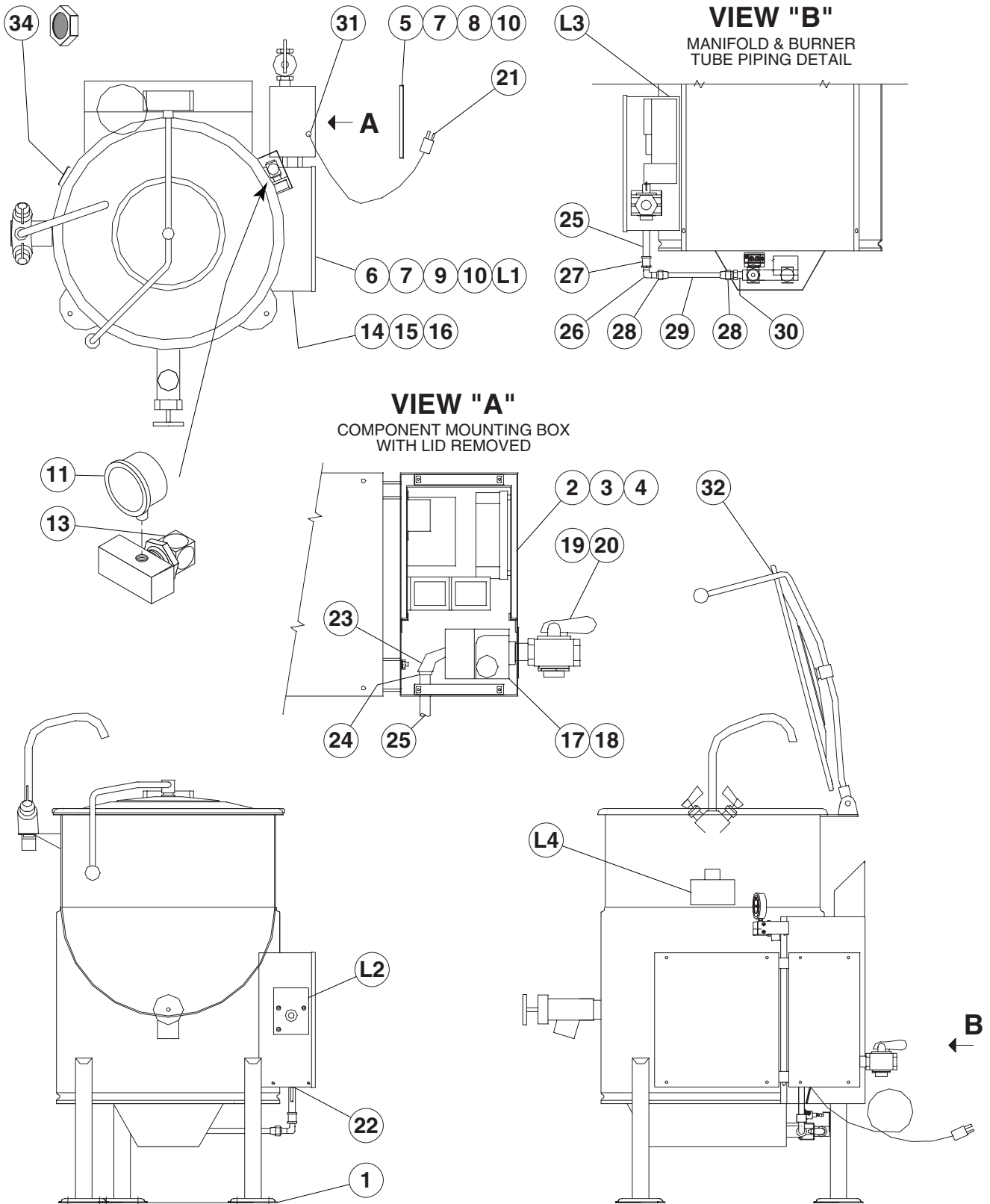

GENERAL ASSEMBLY - STATIONARY MODELS (pg. 2 of 2)

ITEM NO.	PART NO.	DESCRIPTION	QTY.
1.	KE00099	ADJUSTABLE FOOT	3
2.	KE01928-2	COMPONENT MOUNTING PLATE ASSEMBLY (see COMPONENT MOUNTING PLATES)	1
3.	FA20006	MACHINE SCREW NUT (10-24)	1
4.	FA32006	TOOTH LOCK WASHER	1
5.	KE54991-1	LID (COMPONENT BOX)	1
6.	KE54991-2	LID (SIDE BOX)	1
7.	FA95074	ANCHOR NUT	8
8.	KE54846-4	GASKET (COMPONENT BOX LID)	1
9.	KE54846-5	GASKET (SIDEBOX LID)	1
10.	FA95031	PAN HEAD PHILLIPS DRIVE SCREW	8
11.		PRESSURE GAUGE	
	KE000714-4	FOR UNITS BUILT PRIOR TO FEBRUARY 2005	1
	KE50429-5	FOR UNITS BUILT AFTER JANUARY 2005	1
13.	KE54941-6	SAFETY VALVE (50 PSI)	1
14.	KE55069-8	SAFETY THERMOSTAT	1
15.	KE003868	THERMISTOR ASSEMBLY	1
16.	KE50556-1	LOW WATER PROBE	1
17.	KE02053	GAS VALVE ASSEMBLY	1
18.	FA10360	SCREW PAN HEAD PHILLIPS (10-32)	2
19.	F01518-1	GAS SHUT OFF VALVE (OPTION)	1
		<i>GAS OPTIONS:</i>	
	KE54618-1	PRESSURE REGULATOR (PROPANE)	1
	KE54618-2	PRESSURE REGULATOR (NATURAL GAS)	1
20.	FI00607	CLOSE NIPPLE	1
21.	KE54821-8	SUPPLY CORD (OPTION)	1
22.	KE54833-2	SNAP IN BUSHING	1
23.	FA00152	STREET ELBOW (3/4)	1
24.	FI00355	BUSHING (3/4 X 3/8)	1
25.	FI00565-3	NIPPLE (3/8)	1
26.	FI05198-5	COMPRESSION ELBOW	1
27.	FI00265	COUPLING (3/8)	1
28.	FI05134-1	COMPRESSION FITTING	2
29.	KE54667-4	BURNER TUBE	1
30.	FI00565-6	NIPPLE (3/8 NPT)	1
31.	KE51238	CORD CONNECTOR	1
32.	CHS-25	SPRING HINGE COVER	1
34.	KE54468	WATER LEVEL SIGHT GLASS	1
		<i>LABELS</i>	
L1.	KE90424	WIRING DIAGRAM	1
L2.	KE95555-5	OPERATING INSTRUCTION LABEL	1
L3.	KE95552	RATING PLATE	1
L4.	KE95551	LABEL SHEET	1

GENERAL ASSEMBLY - TILTING MODELS (pg. 1 of 3)

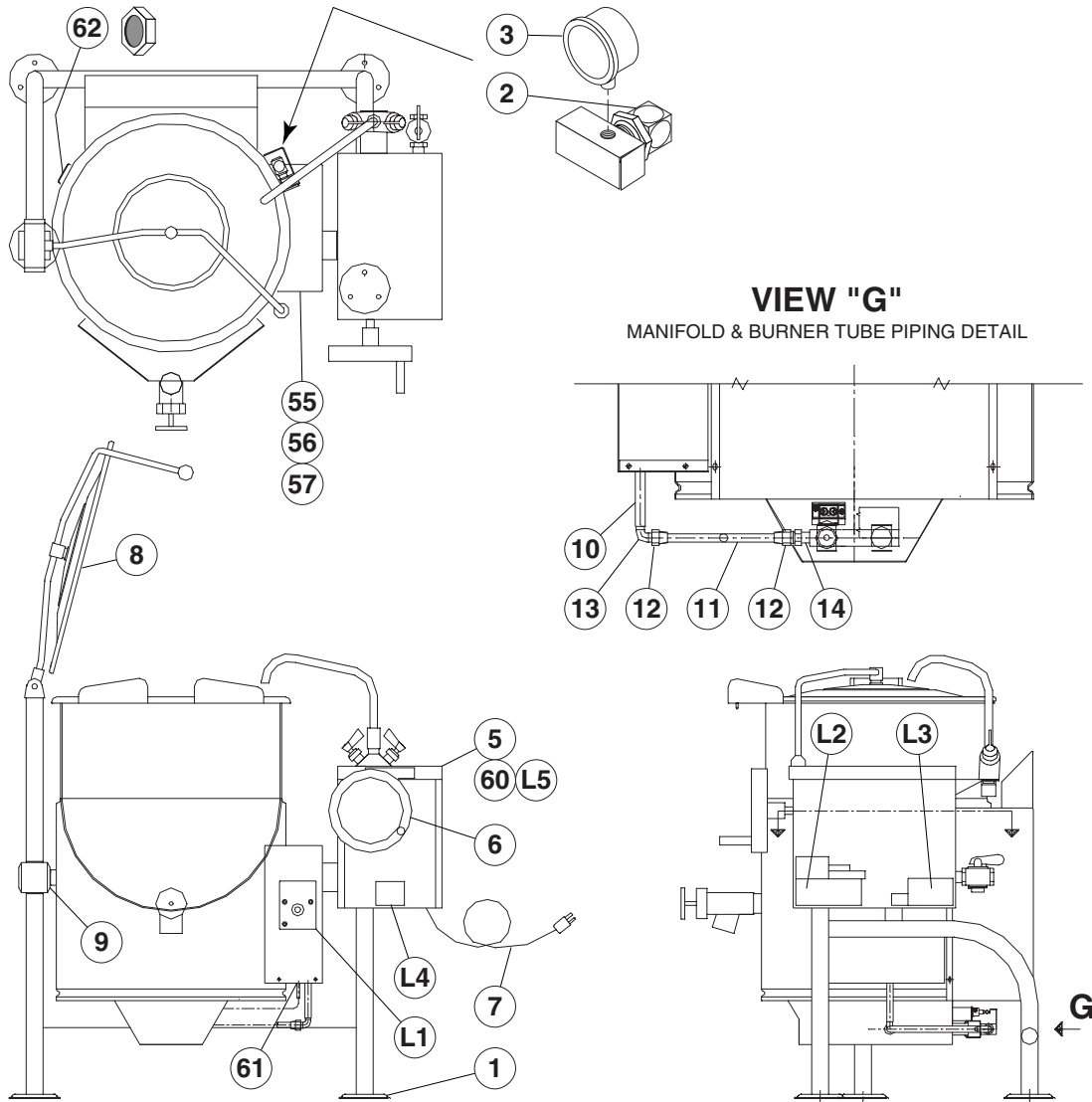

ITEM NO.	PART NO.	DESCRIPTION	QTY.
1.	KE00099	ADJUSTABLE FOOT	1
2.	KE51723-1	SAFETY VALVE (50 PSI)	1
3.		PRESSURE GAUGE	
	KE000714-4	FOR UNITS BUILT PRIOR TO FEBRUARY 2005	1
	KE50429-5	FOR UNITS BUILT AFTER JANUARY 2005	1
5.	KE529773	LID FOR GEAR BOX	1
6.	KE00508	HANDWHEEL	1
7.	KE54821-8	SUPPLY CORD	1
8.	CHS-KGL-25-T	SPRING HINGE COVER	1
9.	See Trunnion Assembly Page		1
10.	FI05321-1	NIPPLE	1
11.	KE54667-3	BURNER TUBE	1

GENERAL ASSEMBLY - TILTING MODELS (pg. 2 of 3)

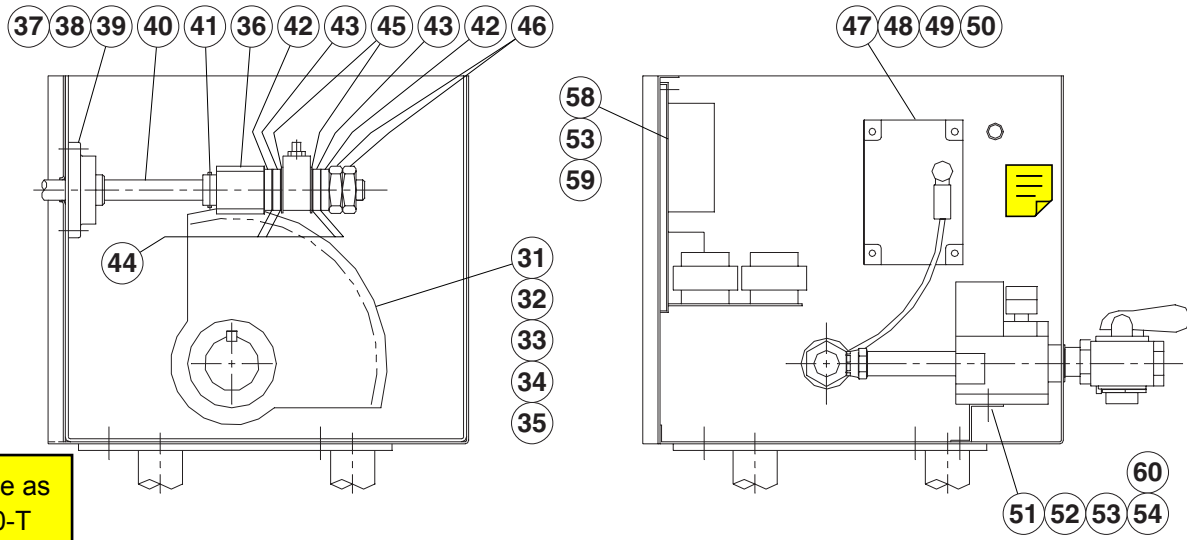
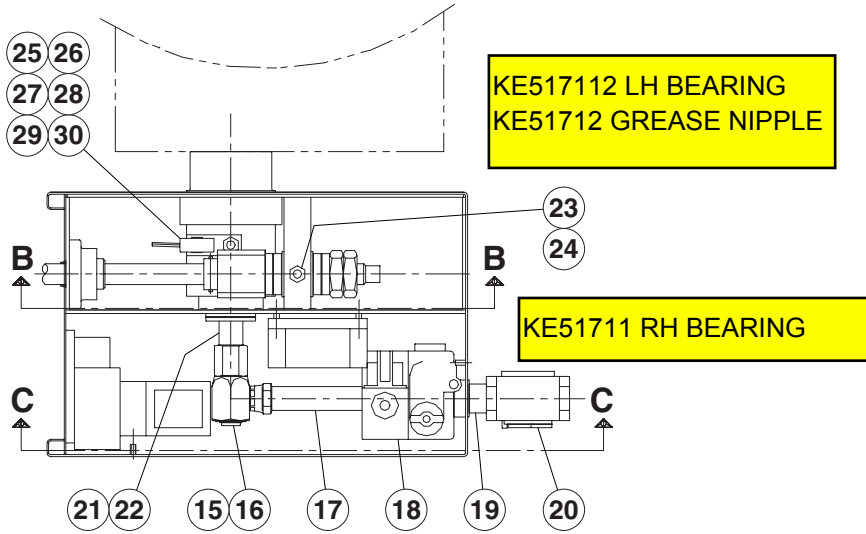

Gear box same as KGL-40 to 100-T

12.	FI05134-1	COMPRESSION FITTING	2
13.	FI05198-5	COMPRESSION ELBOW	1
14.	FI00565-6	NIPPLE 3/8 NPT	1
15.	FI05222	SWIVEL ELBOW	1
16.	FI05231	FLUSH BUSHING	1
17.	FI05223	SPECIAL NIPPLE	1
18.	KE02053	GAS VALVE ASSEMBLY	1
19.	FI00607	CLOSE NIPPLE	1
20.	F01518-1	GAS SHUT OFF VALVE	
	<i>GAS OPTIONS:</i>		
	KE54618-1	PRESSURE REGULATOR (PROPANE)	1
	KE54618-2	PRESSURE REGULATOR (NATURAL GAS)	1
21.	F105226-12	NIPPLE	1

GENERAL ASSEMBLY - TILTING MODELS (pg. 3 of 3)

22.	FI00040	ELBOW	1
23.	FA19177	HEX SOCKET SET SCREW	1
24.	FA20047	JAM NUT	1
25.	KE50294-1	MERCURY SWITCH	1
26.	KE54456-1	MERCURY SWITCH BRACKET	1
27.	KE50295-1	CLIP FOR MERCURY SWITCH	
28.	FA11396	HEX HEAD BOLT (3/8-24)	1
29.	FA31031	SPLIT LOCK WASHER	1
30.	FA15018-7	SCREW 6-32	1
31.	KE52833	WORM GEAR	1
32.	FA10772	SOCKET HEAD CAP SCREW	2
33.	FA20030	JAM NUT	2
34.	FA95007-4	RETAINING RING	1
35.	FA95055-1	SQUARE KEY	1
36.	KE50315	WORM	1
37.	KE51730	TILT SHAFT BEARING	1
38.	FA31010	SPLIT LOCK WASHER	2
39.	FA20030	HEX NUT	2
40.	KE503752	TILT SHAFT	1
41.	FA95005	TENSION PIN	1
42.	KE52193	THRUST BEARING SPACER	2
43.	KE52191	ROLLER BEARING	2
44.	KE52192	THRUST WASHER	4
45.	FA30088	WASHER	2
46.	FA95008	JAM NUT	2
47.	KE53469-2	IGNITION CONTROL 	1
	KE54308-4	IGNITION CONTROL	1
48.	FA10245	SCREW (8-32)	4
49.	FA20004	HEX NUT	4
50.	FA32005	TOOTH LOCKWASHER	4
51.	KE53390	GAS VALVE MOUNTING BRACKET	1
52.	FA10367	BINDING HEAD SCREW (10-32)	2
53.	FA32006	TOOTH LOCKWASHER (J10)	2
54.	FA20007	MACHINE SCREW NUT (10-32)	2
55.	KE55069-6	SAFETY THERMOSTAT	1
56.	KE00515	THERMISTOR ASSEMBLY	1
57.	KE50556-1	LOW WATER PROBE	1
58.	KE01928-1	COMPONENT MOUNTING PLATE ASSEMBLY (see COMPONENT MOUNTING PLATES)	1
59.	FA20006	MACHINE SCREW NUT (10-24)	2
60.	FA11145	SCREWS	4
61.	KE54833-2	SNAP-IN BUSHING	1
62.	KE54468	WATER LEVEL SIGHT GLASS	1
LABELS			
L1.	KE95555-5	OPERATING INSTRUCTION LABEL	1
L2.	KE95552	RATING PLATE	1
L3.	KE95551	GAS KETTLE LABEL GENERAL	1
L4.	KE95040	DIRECTION OF TILT LABEL	1
L5.	KE90424	WIRING DIAGRAM	1

TRUNNION ASSEMBLY

ITEM NO.	PART NO.	DESCRIPTION	QTY.
1.	KE00354	TRUNNION BEARING ASSEMBLY (INCLUDES PART # 3 & 6)	1
2.	KE00351	TRUNNION BEARING ASSEMBLY (INCLUDES PART # 3 & 6)	1
3.	KE51711	ROLLER BEARING	2
4.	KE50666	SPHERICAL WASHER	1
5.	FA95081-3	BOLT, 5/16-18 X 1/2"	1
6.	KE51886	GREASE NIPPLE	2
7.	FA95027	MODIFIED BOLT, 5/16-18 X 1 1/2"	4/2

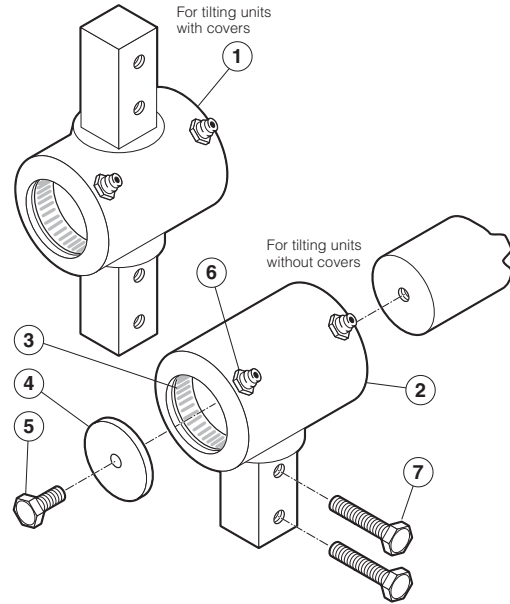

TANGENT DRAW-OFF VALVE

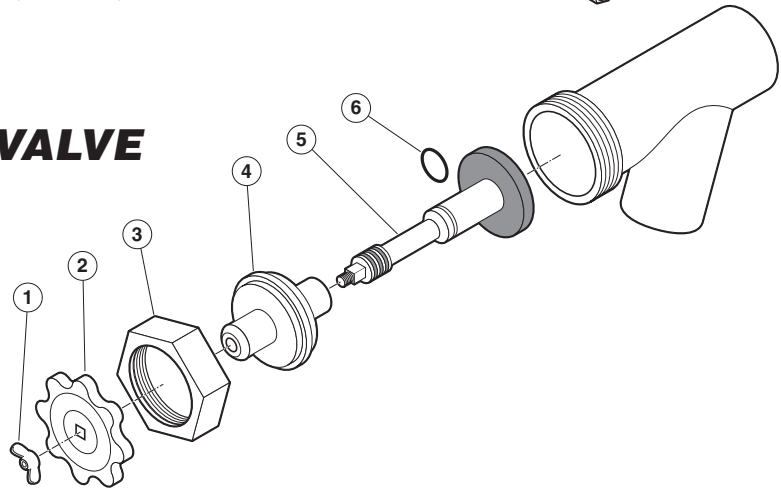

ITEM NO.	PART NO.	DESCRIPTION	QTY.
Complete	KE50972-B	2" DRAW-OFF ASSEMBLY (TD-2)	1
Valve	KE50973	3" DRAW-OFF ASSEMBLY (TD-3)	1
	KE02044-2	2" DRAW-OFF ASSEMBLY (TD-2A with ACME THREAD)	1
	KE02044-4	3" DRAW-OFF ASSEMBLY (TD-3A with ACME THREAD)	1
1.	FA95049	WING NUT, TD-2	1
	FA21050	ACCORN NUT, TD-2	1
	FA21501-1	ACCORN NUT, TD-3	1
2.	KE52755	KNOB, TD-2	1
	SE50018	KNOB, TD-3	1
3.	FI05180-1	HEX NUT, TD-2	1
	FI05180-2	HEX NUT, TD-3	1
4.	KE52753	RETAINER, TD-2	1
	SE50013	RETAINER, TD-3	1
5.	KE52752	PISTON, TD-2	1
	SE50010	PISTON, TD-3	1
6.	FA05002-24	"O" RING, TD-2	1
	FA05002-38	"O" RING, TD-3	1

CONSOLE CONTROLS

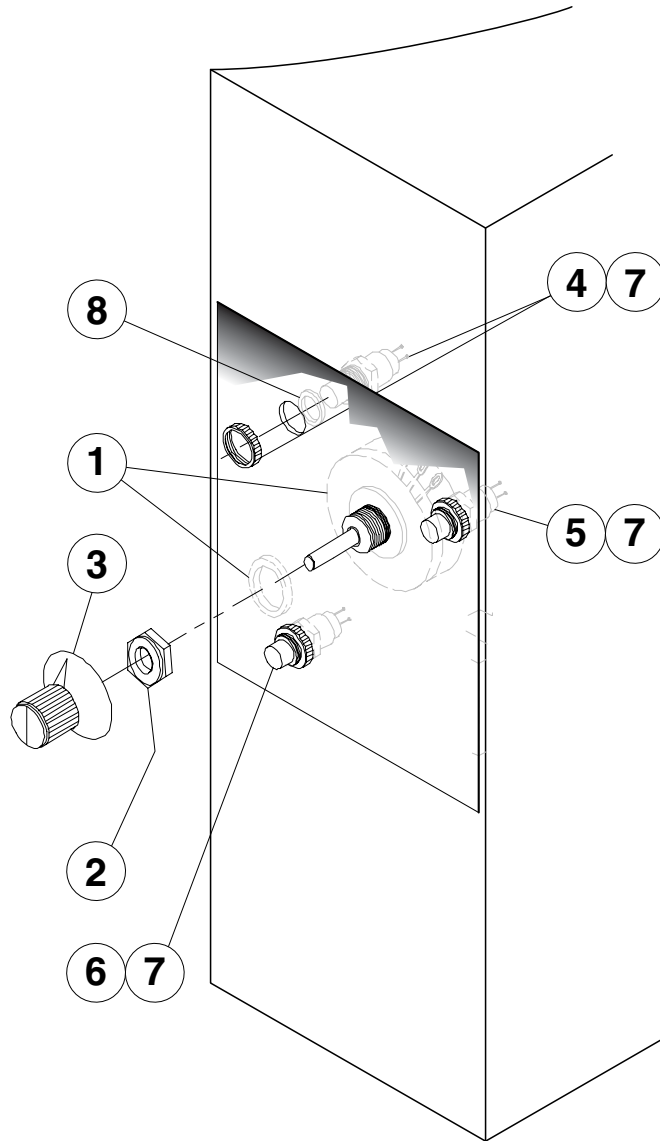

ITEM NO.	PART NO.	DESCRIPTION	QTY.
1.	SE00114	POTENTIOMETER WITH ON/OFF SWITCH, C/W ITEM #2	1
2.	KE51005	RUBBER BOOT	1
3.	KE50569-1	KNOB, POTENTIOMETER	1
4.	SE003013-1	L.E.D., RED, Replacement Kit., (includes LED & "O" Ring)	1
5.	SE003013-2	L.E.D., GREEN, Replacement Kit., (includes LED & "O" Ring)	1
6.	SE003013-3	L.E.D., AMBER, Replacement Kit., (includes LED & "O" Ring)	1
7.	FA05002-18	"O" RING	3

HINGE ASSEMBLY

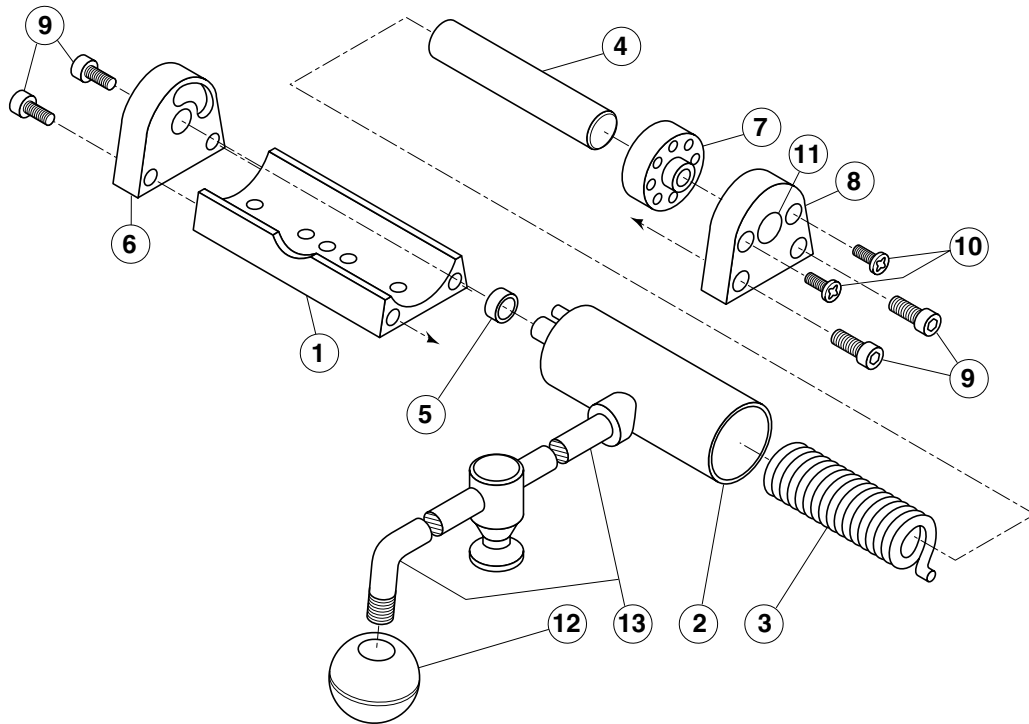

ITEM NO.	PART NO.	DESCRIPTION	QTY.
		Hinge Assembly	
1. - 11	KE50597-1	25 - 40 Gallon, 20 Gallon Full Jacketed	1
	KE50597-2	60 - 80 Gallon, 30 - 40 Gallon Full Jacketed	1
	KE50597-3	100 - 150 Gallon, 60 - 100 Gallon Full Jacketed	1
	KE50597-4	KDM-60, KDM-60-T, Cook Tank	1
	KE50597-5	KDL-200, KDL-250, KDL-150-F, KDL-250-F	1
1.	KE50822	Hinge Base	1
2.	KE51217	Hinge Cylinder	1
3.	KE50121-2	Hinge Spring Light - for KE50597-2	1
	KE50121-1	Hinge Spring Heavy - for KE50597-1, KE50597-3, KE50597-4, KE50597-5, ..	1
4.	KE50823-1	Hinge Pin	1
5.	KE50824	Hinge Bearing	1
6.	KE50819-1	Hinge End Piece	1
7.	KE50820	Hinge Insert	1
8.	KE50819	Hinge End Piece	1
9.	FA11284	Screw, Socket Head	4
10.	FA11507	Cutting Screw,	2
11.	SK50418	Plug Button	1
12.	KE50151-2	Knob	1
13.		Cover Handle (specify model)	1

MAINTENANCE

ALL SERVICE MUST BE PERFORMED BY A QUALIFIED SERVICE TECHNICIAN.

IMPORTANT!
ENSURE KETTLE IS AT ROOM TEMPERATURE AND PRESSURE GAUGE IS SHOWING ZERO OR LESS PRESSURE PRIOR TO REMOVING ANY FITTINGS.

Cleveland Range equipment requires little preventative maintenance. We do however provide the following chart as a guideline for inspection and maintenance to keep your unit functioning at 100%.

INSPECTION AND MAINTENANCE CHECKLIST

The following check should be completed every six months or more frequently if unit is in a high volume facility.

WARNING: It is imperative that damaged seals be repaired immediately to prevent equipment failure and/or damage.

ITEM	CHECK
HAND WHEEL (tilting models only)	Check hand wheel for tightness. If loose tighten allen screw.
LUBRICATION (tilting models only)	Check that kettle tilts smoothly. Grease trunnion housings and gear/worm assembly every three months as recommended in LUBRICATION PROCEDURE.
GEAR/WORM	Inspect for play. Tighten Allen screws if required.
PRESSURE GAUGE	Check that the gauge does not have moisture on its inside face. Replace if moisture is present. Check that the gauge shows a vacuum (needle is well into the Green zone) when cold and shows between 25-40 psi when unit is hot. If not follow VACUUM LEAK TEST.
PRESSURE RELIEF VALVE	Check pressure relief valve as described in PRESSURE RELIEF VALVE TESTING PROCEDURE.
TEMPERATURE CHECK	Following the CALIBRATING PROCEDURE, check the inner kettle surface temperature with a digital surface thermometer and adjust if required.
ON/OFF SWITCH/ TEMPERATURE CONTROL	Check for damage. Replace if necessary.
SPRING ASSIST COVER	Check cover is tightly secured to handle and insure spring is holding cover up - adjust if required. Refer to HINGE ADJUSTMENT INSTRUCTIONS.

SAFETY INSPECTION CHECKLIST-

TILTING MODELS (pg. 1 of 2)

Regular inspection and maintenance of units is essential to obtain trouble free and safe operation of equipment. Inspections must include testing of the pressure relief valve and checks of the operating system to insure that it has not been altered.

No safety features designed into the equipment should ever be tampered with.

Tampering with or bypassing controls is a very dangerous practice and unfortunately we have seen several cases of this. Following is a short list of the most common and the most dangerous alterations performed on kettles.

SAFETY VALVE:

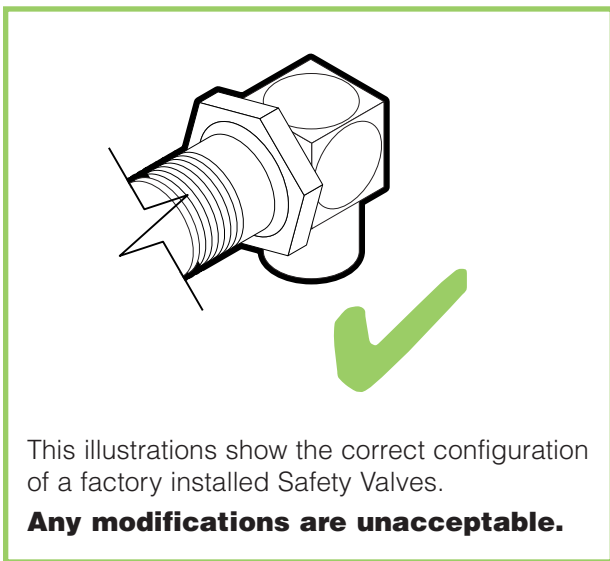

Incorrect Installations

- 1** Safety valve has plug threaded into the discharge opening preventing any steam from escaping.
- 2** Safety valve's tube diameter has been reduced.
- 3** Safety valve is sticking, frozen shut or plugged. To test, refer to PRESSURE RELIEF VALVE PERIODIC TESTING PROCEDURE.
- 4** Safety valve is plumbed to a drain or water line creating back pressure and reducing flow.

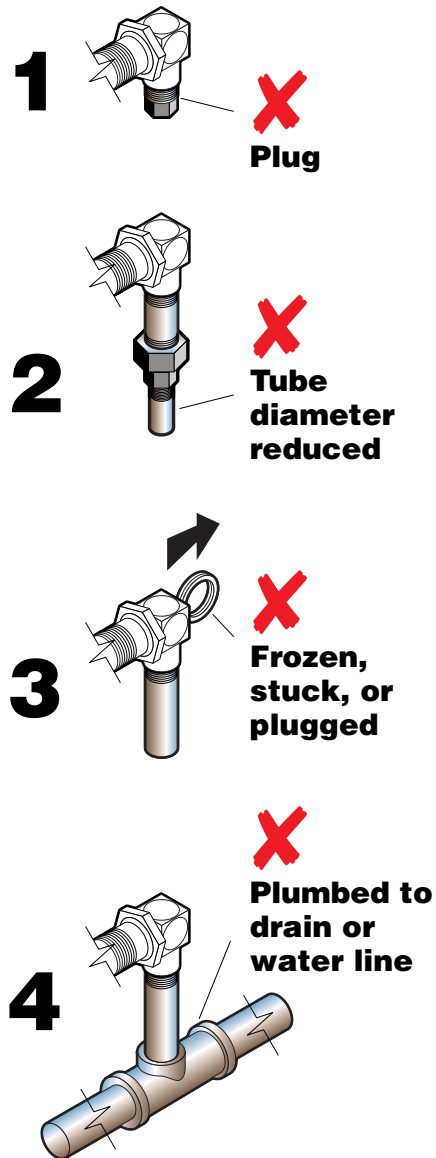

This illustrations show the correct configuration of a factory installed Safety Valves.

Any modifications are unacceptable.

SAFETY INSPECTION CHECKLIST-

TILTING MODELS (pg. 2 of 2)

SAFETY THERMOSTAT:

Incorrect Installations

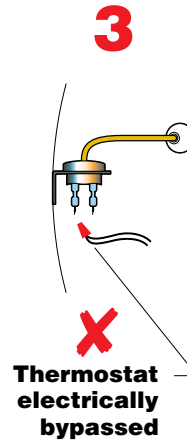
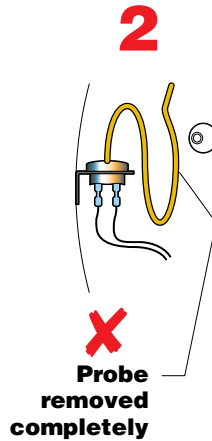
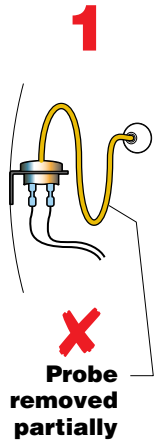
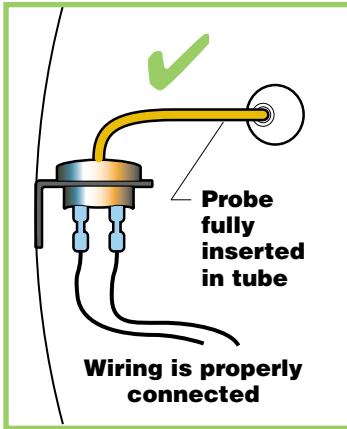

1 Safety thermostat probe is not completely inserted into tubing.

2 Safety thermostat probe is removed from tubing.

3 Safety thermostat electrical connection is bypassed.

Low Water Level Probe:

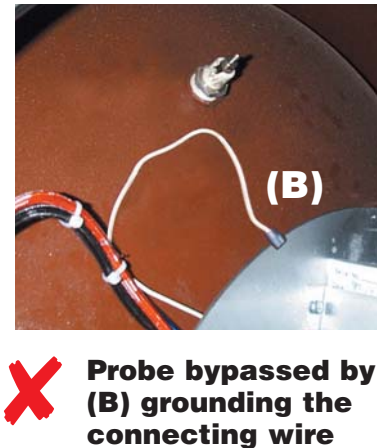
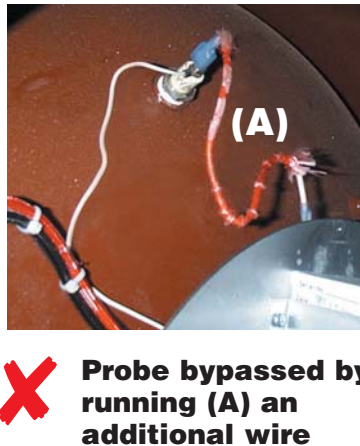

Operating Thermostat:

265°

260° - 270°
MAXIMUM
KETTLE
TEMPERATURE

If maximum temperature is not in this range (on empty kettle), refer to the CALIBRATING PROCEDURE.

LUBRICATION PROCEDURE

Lubricate the following parts every three months to insure smooth operation and reduce wear.

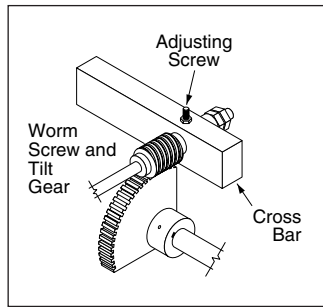

TRUNNION HOUSING, WORM SCREW AND TILT GEAR

These parts are accessed through the top cover of the console.

Apply grease to gear teeth. Check for

excessive play and adjust with adjusting screw located on top of cross bar.

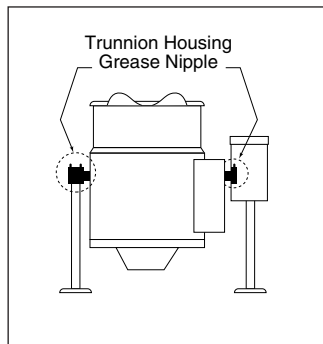

KETTLE TRUNNIONS

On the left hand side of the kettle there are two grease nipples on the top back portion of the trunnion housing. On the right hand side of the kettle you must remove the console cover to access the grease nipple.

HINGE ADJUSTMENT INSTRUCTIONS

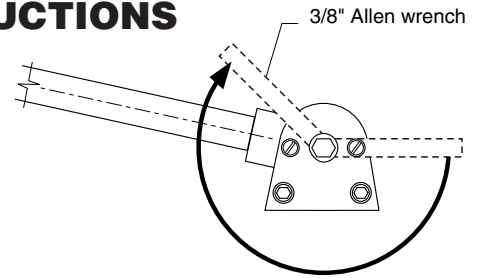

1. Insert 3/8" Allen wrench.
2. Turn clockwise to relieve tension on spring.
3. While tension is released remove one of the two slotted screws.
4. To prevent Allen wrench from springing back abruptly while the second slotted screw is removed, insert a pin (approximately 1/8") in the hole where the first slotted screw was removed from.
5. Remove second slotted screw.
6. While holding Allen wrench remove pin.
7. Turn Allen wrench clockwise to tighten or counter-clockwise to loosen tension to produce desired effect.
8. Re-insert pin in one of the two holes.
9. Tighten one slotted screw in the other hole (it may be necessary to turn Allen wrench slightly to align holes).
10. Remove pin and repeat step number 9. for other slotted screw.

CALIBRATING PROCEDURE

1. Insure the unit has a vacuum before you begin calibrating procedures. If unit requires venting refer to Kettle Venting Instructions.
2. Set On-Off Switch/Temperature Control to "10" (Max.).
3. Allow the unit to cycle twice.
4. Check temperature of the inner kettle surface with a digital surface thermometer.
5. Temperature should be between 260° F and 265° F.
6. Using a screw driver adjust temperature by turning the potentiometer on the black box. Turn very little. Turn clockwise to INCREASES and counter-clockwise to DECREASE temperature.
7. Allow the unit to cycle twice.
8. Check temperature of the inner kettle surface with a digital surface thermometer.
9. Repeat steps 4. through 8. until unit is calibrated.

PRESSURE RELIEF VALVE PERIODIC TESTING PROCEDURE

Most insurance agencies require periodic testing of

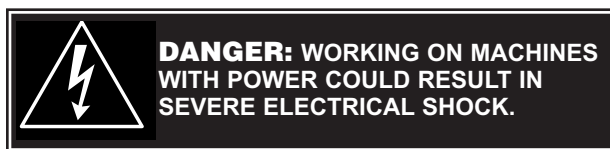
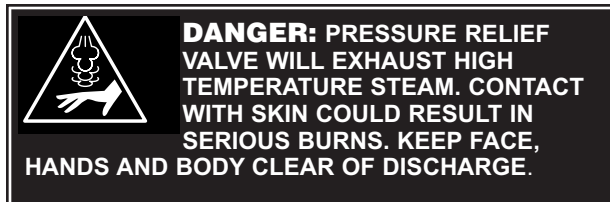

pressure relief valves used on pressure vessels. This procedure will allow you to safely and quickly test your kettle's pressure relief valve. We recommend this test be performed twice a year.

NOTE: The following instruction is intended for use by qualified service personnel.

WARNING: Kettle surface will be hot and steam will be released during testing. Take necessary precautions including the use of gloves and eye protection to prevent personal injury.

1. With the kettle empty, set On-Off Switch/Temperature Control to "10" (Max.). Allow the kettle to heat until the unit cycles off.
2. Switch On-Off Switch/Temperature Control to "0" (Off) and disconnect main power at fused disconnect switch.

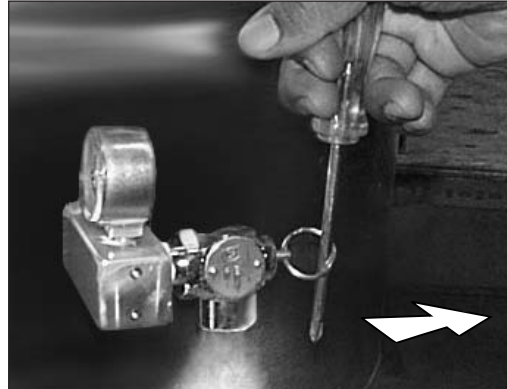

3. Stand to the side of the pressure relief valve discharge tube and pull valve open for a maximum of one second. Repeat test three to four times. Each time the mechanism should move freely and be accompanied by a rapid escape of steam.

If valve appears to be sticking replace pressure relief valve.

If foreign material is discharged then drain kettle (see KETTLE JACKET CLEANOUT & PASSIVATION PROCEDURES) and replace pressure relief valve.

See RESERVOIR FILL PROCEDURE for full instructions on the correct method for refilling kettle jacket.

WARNING: Improper refilling of kettle jacket will result in irreversible damage to unit.

NOTE: Rust inhibitor is purchased locally. Read directions and do not exceed manufacturer's recommendation (excessive rust inhibitor can also cause solidification).

RESERVOIR FILL PROCEDURES

WARNING: IMPROPER REFILLING OF KETTLE JACKET WILL RESULT IN IRREVERSIBLE DAMAGE TO UNIT.

The kettle's water level must be maintained at the proper level. Under normal operating conditions, the sealed water reservoir should never require the addition of water.

If the red "low water" light comes on during use (while the kettle is in an upright position), the water level has reached a critically low level. The low water protection control has automatically shut off the gas burner. The following procedure must be completed before further use:

 **DANGER: PRESSURE RELIEF VALVE WILL EXHAUST HIGH TEMPERATURE STEAM. CONTACT WITH SKIN COULD RESULT IN SERIOUS BURNS. KEEP FACE, HANDS AND BODY CLEAR OF DISCHARGE.**

 **DANGER: WORKING ON MACHINES WITH POWER COULD RESULT IN SEVERE ELECTRICAL SHOCK.**

NOTE: Have a qualified service technician repair the leakage problem and add water to the unit. Ensure that the red "low water" light is on when the kettle is upright. On tilting kettles, it is normal for the red light to come on when the kettle is in a tilted position.

DISTILLED WATER REQUIREMENTS

	When red "Low Water Light" comes on, add distilled water
25 gallon Kettle Capacity	Approximately 1 gal.

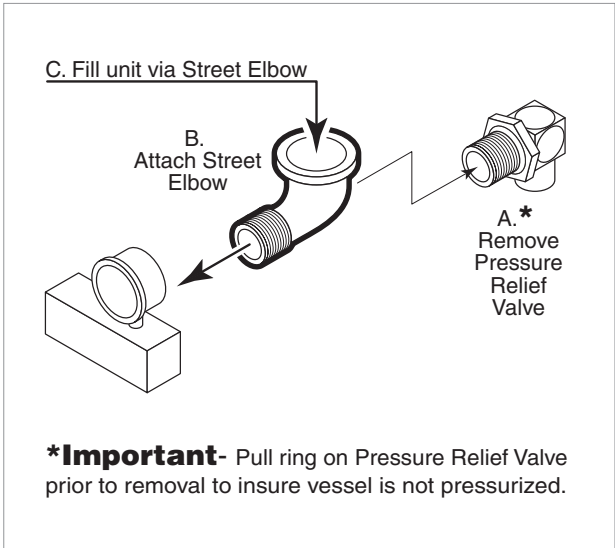

Pressure Relief Valve/Gauge Assembly Drawing

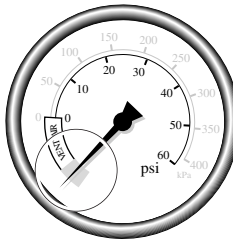

1. Ensure kettle is at room temperature and pressure gauge showing zero or less pressure.
2. Shut off power to the kettle at the fused disconnect switch.

3. Pull Pressure Relief Valve (A) open to insure vessel is not pressurized.
4. Remove Pressure Relief Valve (A).
5. Replace Pressure Relief Valve (A) with Street Elbow (B).



6. Add distilled water (C) through the Street Elbow (B), using a funnel if necessary. Fill the unit to the high level mark on the Sight Glass.

7. Apply a thread sealant (i.e. Teflon tape) to the Pressure Relief Valve's (A) thread and replace.
8. Restore power to unit at the fused disconnect switch.
9. The kettle must now be vented. (Refer to the KETTLE VENTING INSTRUCTIONS).

KETTLE JACKET CLEANOUT AND PASSIVATION PROCEDURES

The following procedure should be performed at least once every three years to prevent possible corrosion and ensure the optimum life of the kettle.

WARNING:
IMPROPER REFILLING OF KETTLE JACKET WILL RESULT IN IRREVERSIBLE DAMAGE TO UNIT.

DANGER:
WORKING ON MACHINES WITH POWER COULD RESULT IN SEVERE ELECTRICAL SHOCK.

DANGER:
MOLYFILM 315 IS CORROSIVE, AVOID CONTACT WITH SKIN AND EYES.

DANGER:
EXTREMELY HOT SURFACES. WORK ONLY ON COLD KETTLE.

DANGER:
AVOID INHALATION - VAPORS FROM MOLYFILM 315 MAY BE HARMFUL OR FATAL.

DESCRIPTION - Molyfilm 315 inhibits corrosion in stainless steel and copper. A pH buffer is present to assist in maintaining the appropriate pH to assist in corrosion inhibition.

DISPOSAL - Follow all Federal, State and local codes when disposing of product.

SHELF LIFE - Molyfilm 315's effectiveness will diminish after three years.

REFILL QUANTITIES (ORDERING INFO: 1 Liter Molyfilm 315 Rust Inhibitor - Part# KE600340-1)

IMPORTANT: To ensure satisfactory mixing follow the MIXING / FILLING PROCEDURE described below.

Kettle Size	Volume of Water		Volume of Molyfilm 315	
	U.S. Gal.	Liters	oz.	cc (ml.)
25 U.S. Gal.	4.4	16.6	6	176

MIXING / FILLING PROCEDURE

1. Refer to chart to determine the required volumes of water and Molyfilm 315.
2. In a separate container mix 1/2 gallon of the required volume of water with the total required volume of Molyfilm 315.
3. Pour mixture into kettle.
4. Pour the remaining required volume of water into kettle.

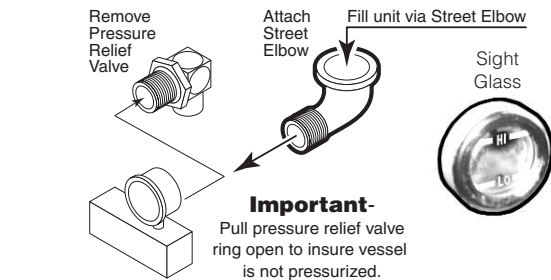

Flushing Procedure



1. Ensure kettle is at room temperature and pressure gauge showing zero or less pressure.
2. Shut off and disconnect gas supply.
3. Remove electrical plug from power source.
4. Remove bolts holding kettle to tabletop/floor.
5. Pull ring on pressure relief valve to insure there is no pressure within the kettle jacket.
6. Remove pressure relief valve.
7. Replace pressure relief valve with street elbow.
8. Remove sight glass.
9. Tilt kettle on its side (sight glass down) and allow to drain. Flush out as much debris as possible with water.
10. Tilt kettle upright, apply a thread sealant (i.e. Teflon tape) to the sight glass threads and replace.
11. Fill jacket via the street elbow with a mixture of water and Molyfilm 315 (see REFILL QUANTITIES).
12. Remove street elbow.
13. Apply a thread sealant (i.e. Teflon tape) to the pressure relief valve and replace.
14. Reconnect gas and electrical supplies.
15. Turn kettle on, vent and heat to high for 1/2 hour.
16. Cool and drain kettle as per above procedure.

Refilling Unit

1. Apply a thread sealant (i.e. Teflon tape) to the sight glass threads and replace.
2. Fill kettle jacket with a mixture of water and Molyfilm 315 (see REFILL QUANTITIES charts).
3. Apply a thread sealant (i.e. Teflon tape) to the filler plug threads and replace.
4. Turn kettle on and check for leaks at sight glass and filler plug. See Vacuum Leak Test.
5. Vent kettle. See Kettle Venting Instructions for proper procedure.

DANGER:
PRESSURE RELIEF VALVE WILL EXHAUST HIGH TEMPERATURE STEAM. CONTACT WITH SKIN COULD RESULT IN SERIOUS BURNS. KEEP FACE, HANDS AND BODY CLEAR OF DISCHARGE.

KETTLE VENTING INSTRUCTIONS

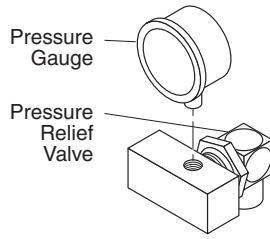
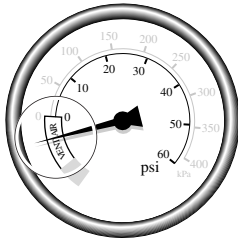

The following venting procedure should be followed when the Vacuum/Pressure Gauge needle is in the "VENT AIR" zone:

NOTE: Check for and eliminate leaks prior to venting (See Repairing Leaks in Steam Jacketed Kettle Fittings.

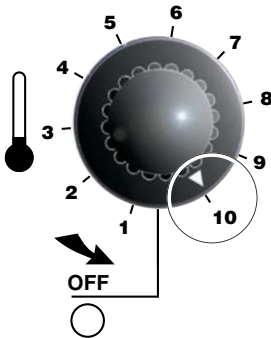
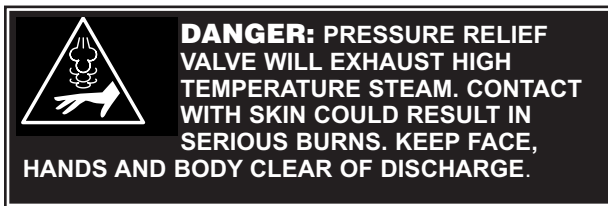

1. Turn kettle ON and set Temperature Control to **10** (Max.), heat the empty kettle until unit cycles off.
2. Vent kettle by pulling safety valve ring 8-10 times in short 2-3 second blasts with a 5 second interval between pulls.

NOTE: If unit cycles ON, stop venting and wait for kettle to cycle OFF before continuing.



3. Turn kettle OFF. Add cold water to kettle until its surface temperature is below 100°F. The pressure gauge needle should be in the green zone, indicating a vacuum in the kettle's jacket.

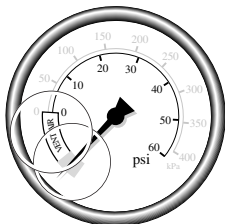

VACUUM LEAK TEST PROCEDURE

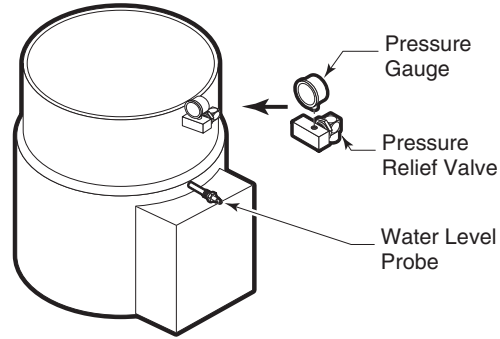

If the kettle will not hold vacuum, test for leaks at:

- A. Water Level Probe.
- B. Pressure Relief Valve.
- C. Pressure Gauge.

LEAK TEST PROCEDURE:

1. Heat kettle until unit cycles off.
2. Shut off power to the kettle at the fused disconnect switch.
3. Spread Bubble Type Leak Detector over suspected areas and watch closely for bubbles.
4. Repair areas as required.

REPAIRING LEAKS IN STEAM JACKETED KETTLE FITTINGS

If unit will not hold a vacuum the most likely cause is a leak at one of the fittings.

Often, the easiest way to eliminate a leak is reseal the suspect areas.

1. Water Level Probe
Remove, clean threads, apply teflon thread sealant and reinstall.
2. Pressure Relief Valve
A/ Inspect for signs of leaks. Replace if required.
B/ Remove, clean threads, apply teflon thread sealant and reinstall.
3. Pressure Gauge
A/ Inspect face of gauge. If it contains moisture on the inside of face replace.

FIELD CONVERSION INSTRUCTIONS -

Natural Gas to Propane Gas

Atmospheric Burner Gas Kettles

	BTU's per Hour	Gas Type	Water Column	# of Orifices
KGT-6-T	34000	NAT	4.2	1
	34000	LP	10	1
KGT-12-T	53000	NAT	4.2	1
	53000	LP	10	1
KGL-25, KGL-25-T	90000	NAT	4.2	2
	90000	LP	10	2

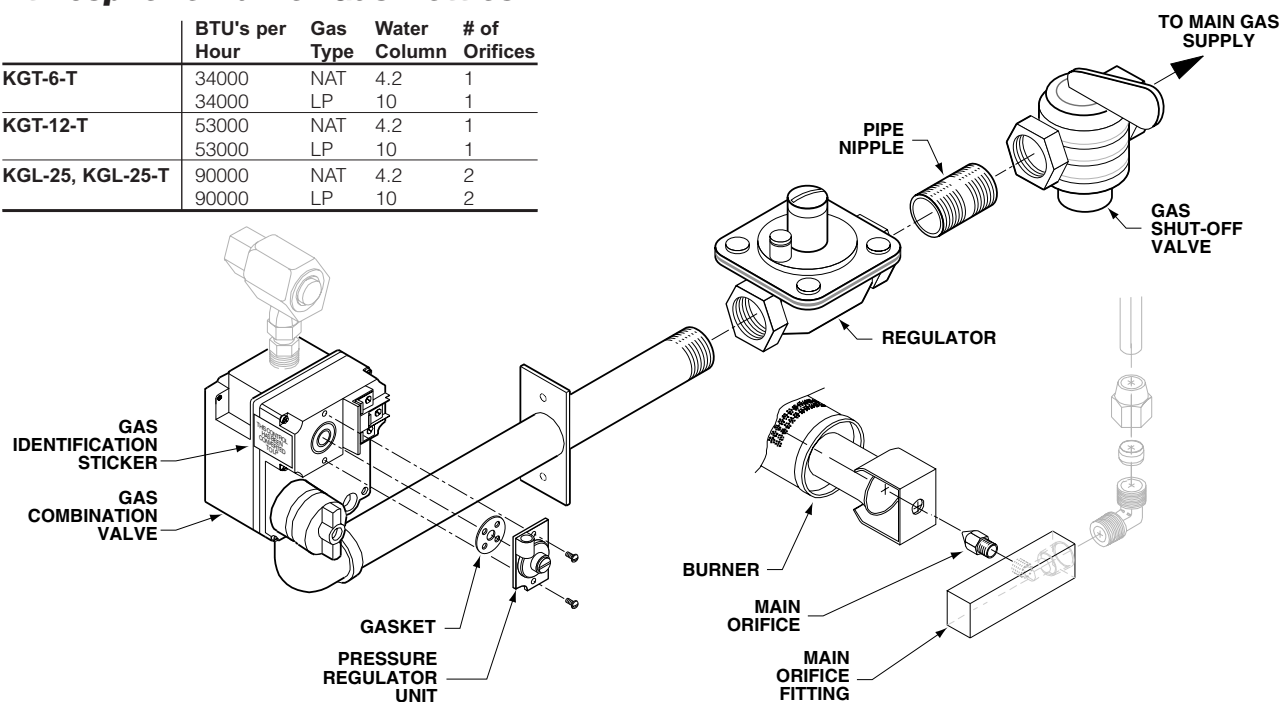

NOTE: Use thread sealant compatible with propane gas on all threaded piping connections.

1. Disconnect electrical connection.
2. Shut off main gas supply and disconnect kettle from supply line.
3. Remove **GAS SHUT-OFF VALVE** from kettle supply pipe and install **REGULATOR** (pre-set to 10 " W.C. pressure) supplied in field conversion kit.
4. Re-install **SHUT-OFF VALVE** using **PIPE NIPPLE** supplied in kit.
5. Remove side cover from control console.
6. Remove **PRESSURE REGULATOR UNIT** from **GAS COMBINATION VALVE** inside console, and replace with blocked **PRESSURE REGULATOR UNIT** from kit. Make sure **GASKET** is correctly seated in recess in **GAS COMBINATION VALVE** during installation.

NOTE:

Place **GAS IDENTIFICATION STICKER** on face of **GAS COMBINATION VALVE**.

7. Tilt kettle. Remove kettle side box cover. Remove screw securing end of **BURNER**. Remove **BURNER**. Support **MAIN ORIFICE FITTING** and remove **MAIN ORIFICE**. Install new orifice from kit.

8. Replace **BURNER**. Check **MAIN ORIFICE/BURNER** alignment insuring **MAIN ORIFICE** points straight into the center of the **BURNER**.
9. Reconnect to gas supply. Turn on propane gas. Tilt kettle to upright position, turn on power and check all gas connections for leaks.
10. Turn off power and main gas supply, and replace all covers. Attach **GAS IDENTIFICATION STICKER** to nameplate.
11. Place gas conversion label next to rating label.

Conversion Parts Required

Part No.	Description	Quantity
KE95549	Conversion Label	1
SE50438	Field Conversion Kit, 6 gallon	1
SE50438-1	Field Conversion Kit, 12 gallon	1

SEQUENCE OF OPERATIONS

- 1.** To turn the unit on, turn the switch to the on position.
 - Power is sent to primary side of the 120vac/16vac transformer.
 - Power is sent to the normally closed high limit.
 - From the high limit power is sent to the normally open contacts of the 12VDC relay.
- 2.** From the secondary of the transformer 16VAC is sent to the controller.
 - Power is sent to the red LED (low water indicator light) from terminal 4 of the controller.
 - If the water probe is grounded through water the LED will go off.
 - If the water probe is not grounded the LED will remain on and the unit will not heat.
 - If the resistance of the thermistor is higher than the setting of the potentiometer(the unit is calling for heat) then 16VDC is sent to the coil of the relay and the green LED (heat indicator light)
 - The 12VDC relay will close until the unit reaches temperature
- 3.** With the contacts of the relay closed, power is sent to the 24 VAC transformer.
 - The transformer sends 24 VAC to the ignition module.
 - Ignition module sends 24 VAC to the Amber LED
 - The ignition module will send spark to the igniter and 24 VAC to the gas valve.
 - With 24VAC to the gas valve the valve opens and gas is sent to the burner.
 - Spark and gas together cause ignition.
 - When this happens and the module reads at least 0.7 micro amps DC within 4 seconds, the Amber light will go out and the 24 VAC will remain on the gas valve.
 - The unit will heat causing the water to boil and steam to be generated.
 - If the module does not see the 0.7 micro-amps in 4 seconds, the module will try again in 15 seconds. It will try 3 times then lock out.
- 4.** The kettle will heat (build pressure) until the controller is satisfied by the thermistor at the setting of the potentiometer.
 - The controller will then turn off the heat circuit until the temperature of the kettle is below the setting.
 - When the temperature drops below the setting the controller will send 12 VDC to the relay and the heat circuit will be energized again.
- 5.** To turn the unit off, place the switch in the off position.
 - Power will be removed from the controller and the heat circuit will de-energize.

**PROBLEM:
KGL-25
Kettle Won't
Heat**

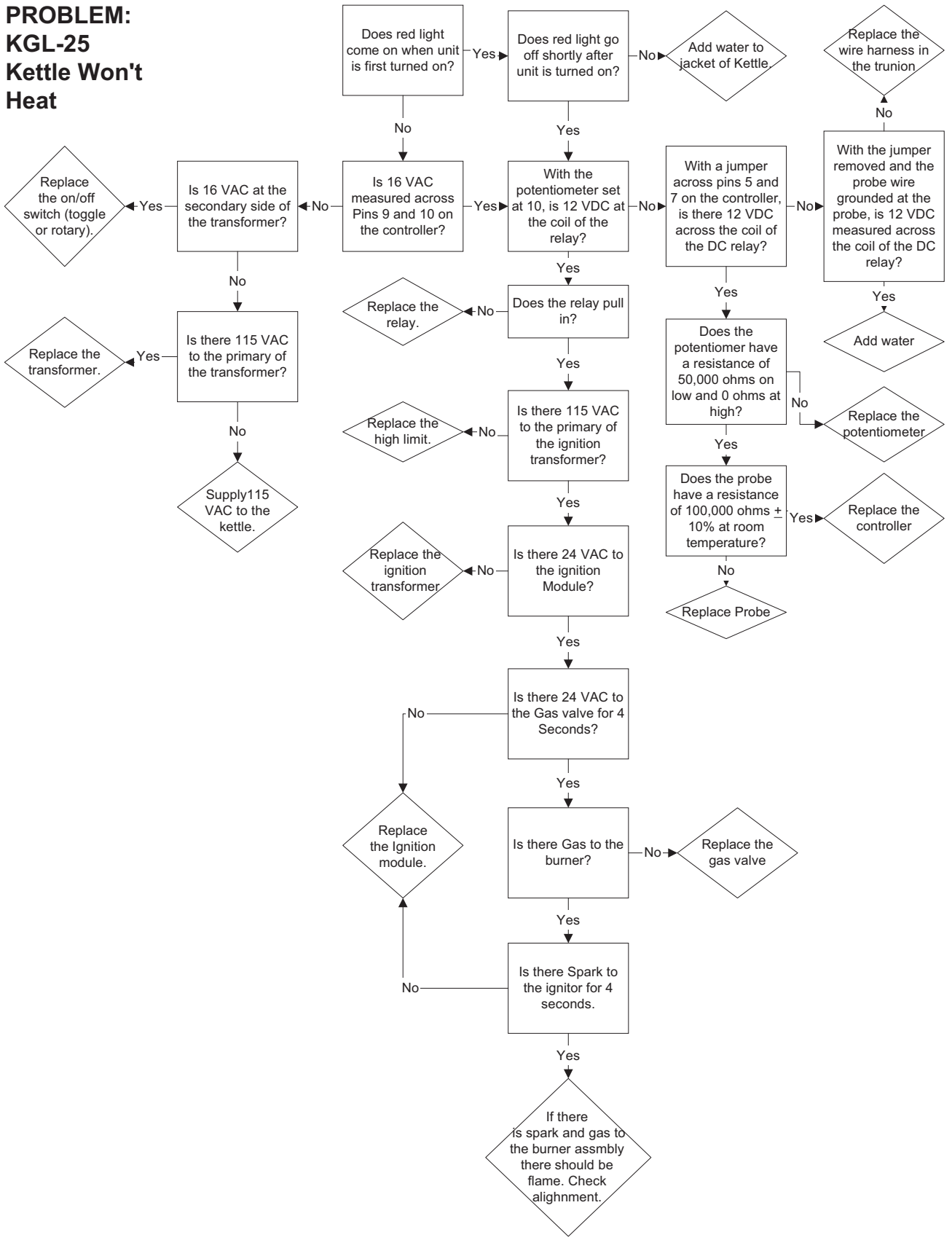

**PROBLEM:
KGL-25
Kettle Not
Hot Enough**

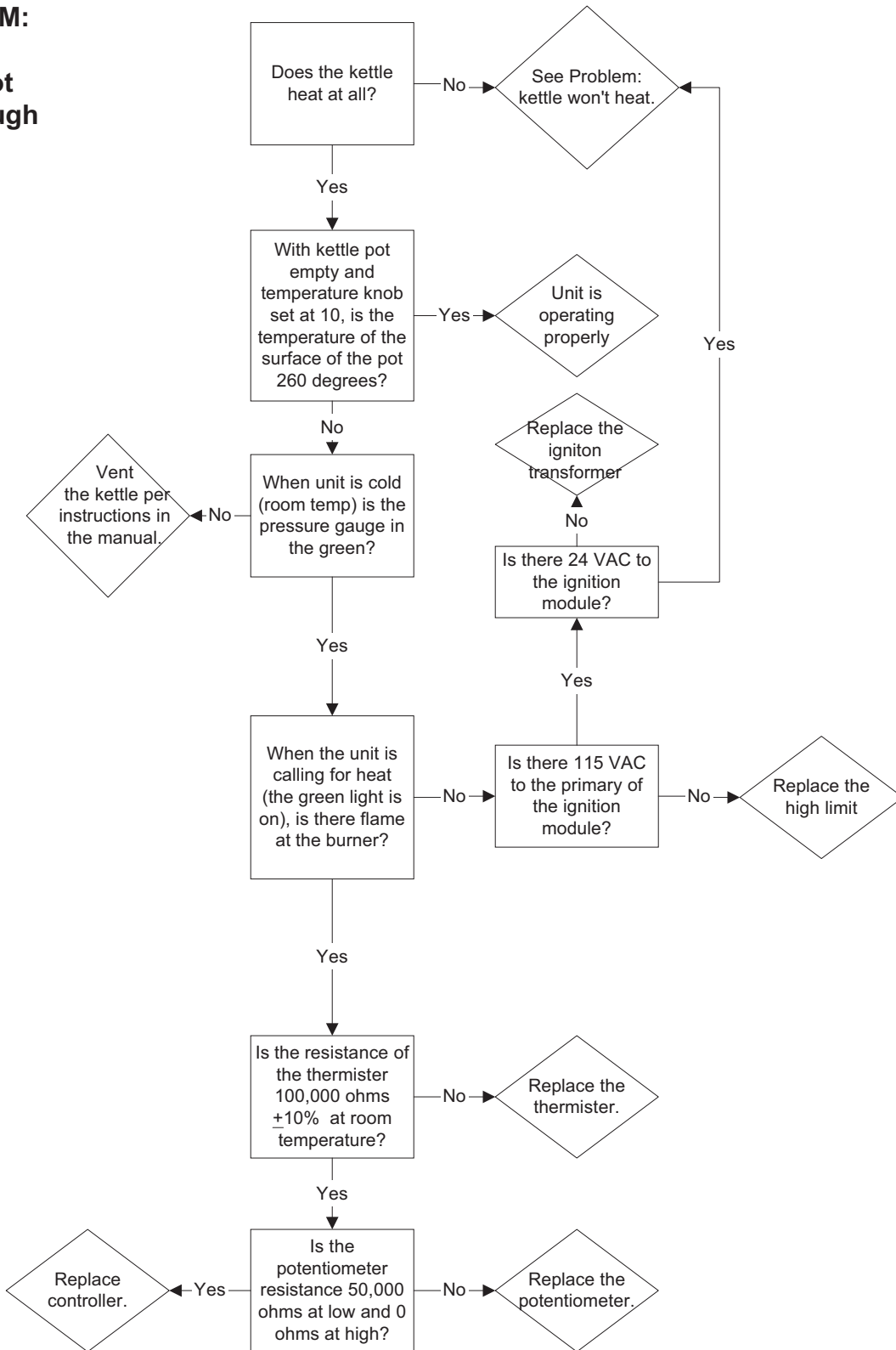

**PROBLEM:
KGL-25
Kettle Gets
Too Hot**

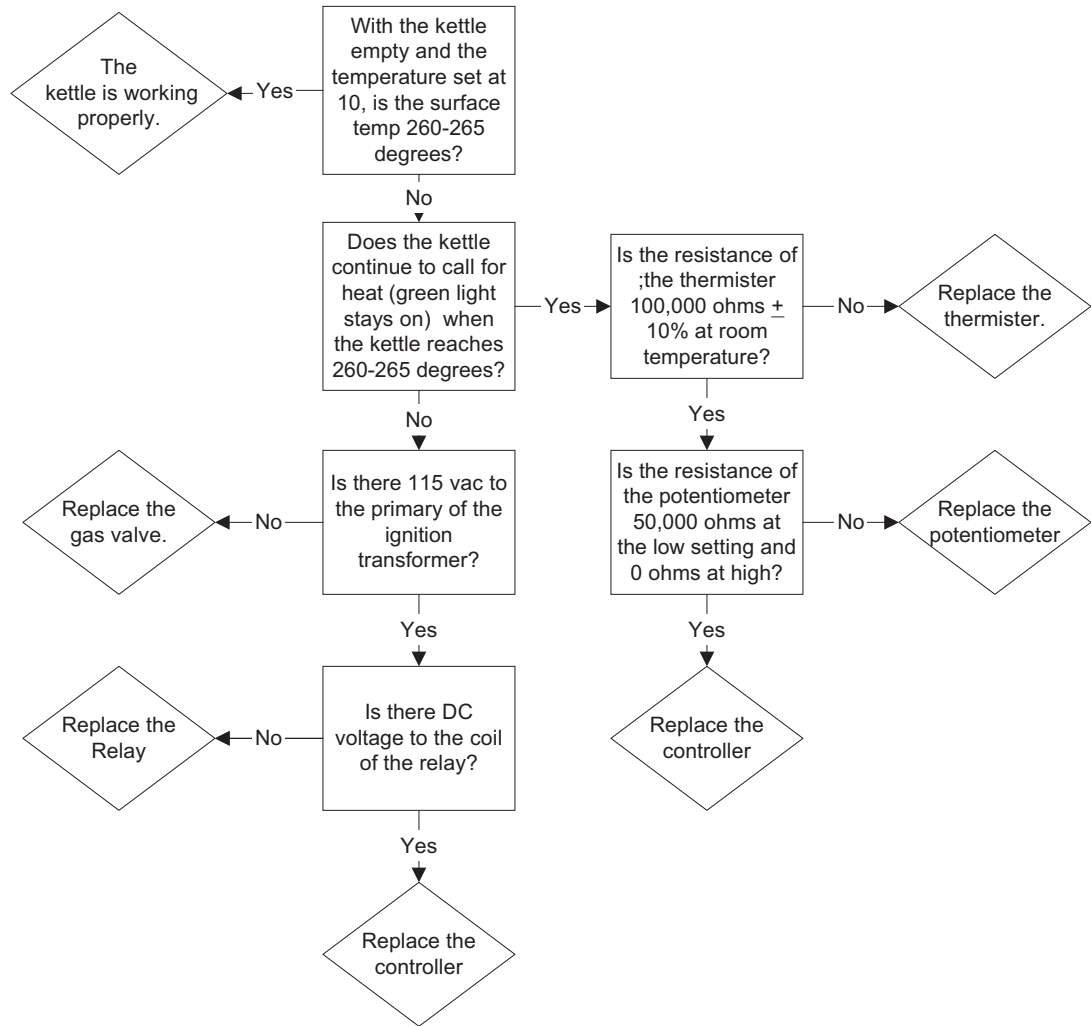

PROBLEM: Red Add Water LED Stays On

