



# Maintenance Procedures & Parts Lists

Gas Floor Model Kettles

*For units built after April 2010*

KGL-40, KGL-60, KGL-80, KGL-100  
KGL-40-T, KGL-60-T, KGL-80-T  
KGL-40-SH, KGL-60-SH,  
KGL-40-TSH

*For your future reference.*

Model # \_\_\_\_\_

Serial # \_\_\_\_\_



 **Cleveland**

1333 East 179th St., Cleveland, Ohio, U.S.A. 44110  
Ph: 216.481.4900 Fx: 216.481.3782  
[www.clevelandrange.com](http://www.clevelandrange.com)

*This manual is to be used in conjunction with the "Operators Manual". See "Operators Manual" for safety warnings, correct operation, installation and preventative maintenance.*

 **Manitowoc**

# **STATEMENT OF RESPONSIBILITIES / DÉCLARATION DES RESPONSABILITÉS / DECLARACIÓN DE RESPONSABILIDADES**

This document is for use by experienced and trained Qualified Cleveland Range, LLC Authorized Service Representatives who are familiar with both the safety procedures, and equipment they service. Cleveland Range, LLC assumes no liability for any death, injury, equipment damage, or property damage resulting from use of, improper use of, or failure to use the information contained in this document. Cleveland Range, LLC has made every effort to provide accurate information in this document, but cannot guarantee that this document does not contain unintentional errors and omissions.

The information in this document may be subject to technical and technological changes, revisions, or updates. Cleveland Range, LLC assumes no liability or responsibility regarding errata, changes, revisions, or updates.

Qualified Cleveland Range, LLC Authorized Service Representatives are obligated to follow industry standard safety procedures, including, but not limited to, OSHA regulations, and disconnect / lock out / tag out procedures for all utilities including steam, and disconnect / lock out / tag out procedures for gas, electric, and steam powered equipment and / or appliances.

All utilities (gas, electric, water and steam) should be turned OFF to the equipment and locked out of operation according to OSHA approved practices during any servicing of Cleveland Range equipment

Qualified Cleveland Range, LLC Authorized Service Representatives are obligated to maintain up-to-date knowledge, skills, materials and equipment.

Ce document est destiné à l'usage des Représentants de Service qualifiés et autorisés de Cleveland Range, LLC qui possèdent l'expérience et la formation ainsi que la bonne connaissance des mesures de sécurité et du matériel qu'ils entretiennent.

Cleveland Range, LLC décline toute responsabilité pour tout cas de décès, blessure, dommage matériel ou dommage aux biens résultant de l'utilisation, de la mauvaise utilisation ou du manquement d'utilisation des renseignements contenus dans ce document.

Cleveland Range, LLC s'est efforcé à fournir des renseignements précis dans ce document mais ne peut garantir que ce document soit exempt d'erreurs et d'omissions non intentionnelles.

Les renseignements contenus dans ce document peuvent être assujettis à des changements techniques et technologiques, des révisions ou des mises à jour.

Cleveland Range, LLC décline toute obligation ou responsabilité concernant les errata, modifications, révisions ou mises à jour.

Les Représentants de Service qualifiés et autorisés de Cleveland Range, LLC sont tenus de se conformer aux mesures de sécurité normalisées de l'industrie, y compris, mais sans s'y limiter, les réglementations de l'OSHA, les procédures de débranchement / verrouillage / étiquetage relatives à tous les services publics, dont l'approvisionnement en vapeur, et les procédures de débranchement / verrouillage / étiquetage relatives aux équipements et/ou appareils fonctionnant au gaz, à l'électricité et à la vapeur.

Au cours de tout entretien d'un appareil Cleveland Range, tous les services publics (gaz, électricité, eau et vapeur) doivent être FERMÉS au niveau de l'appareil et le dispositif de fonctionnement doit être verrouillé suivant les pratiques approuvées de l'OSHA.

Les Représentants de Service qualifiés et autorisés de Cleveland Range, LLC sont tenus d'actualiser en permanence leurs connaissances, compétences, matériel et équipement.

Este documento está destinado para el uso de los Representantes de Servicio calificados y autorizados de Cleveland Range, LLC quienes cuentan con la experiencia y la capacitación así como el buen conocimiento de las medidas de seguridad y de los equipos que mantienen.

Cleveland Range, LLC, declina toda responsabilidad en caso de cualquier fallecimiento, lesiones, daños al equipo o daños a la propiedad resultantes de la utilización, del uso indebido o de la falta de utilización de la información provista en este documento.

Cleveland Range, LLC se ha esforzado en suministrar información precisa en este documento, pero no puede garantizar que este documento esté exento de errores y de omisiones no intencionales.

La información contenida en este documento podría estar sujeta a cambios técnicos o tecnológicos, revisiones o actualizaciones. Cleveland Range, LLC declina toda obligación o responsabilidad con respecto a erratas, modificaciones, revisiones o actualizaciones.

Los Representantes de Servicio calificados y autorizados de Cleveland Range, LLC tienen la obligación de seguir los procedimientos estándar de seguridad de la industria; los cuales incluyen pero no se limitan a los reglamentos de la OSHA (La Administración de la Seguridad y Salud Ocupacionales), los procedimientos de desconexión, cierre y etiquetado relativos a todos los servicios públicos incluyendo el suministro de vapor y los procedimientos de desconexión, cierre y etiquetado para los equipos y/o aparatos que funcionan a base de gas, electricidad o vapor.

Cuando se esté dando servicio o mantenimiento a un aparato de Cleveland Range, todos los servicios públicos (gas, electricidad, agua y vapor) deben estar APAGADOS para el equipo en cuestión y se debe seguir el procedimiento de cierre de operaciones de acuerdo con las prácticas aprobadas por la OSHA.

Los Representantes de Servicio calificados y autorizados de Cleveland Range, LLC tienen la obligación de actualizar constantemente sus conocimientos, destrezas, materiales y equipamiento.

# TROUBLESHOOTING AND MAINTENANCE PROCEDURES

*The following trouble shooting guide and maintenance procedures are meant to be used by Qualified Service Technician*

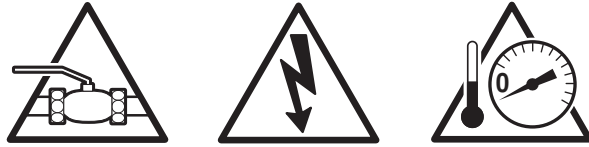

**ANY REPAIRS TO THE PRESSURE VESSEL MUST BE DONE BY A CERTIFIED PRESSURE VESSEL REPAIR SHOP AND ALL REPAIR METHODS AND MATERIALS MUST BE APPROVED BY THE MANUFACTURER.**

**For periodic maintenance recommendations see “Operators Manual”.**

---

## TROUBLESHOOTING GUIDES

### GENERAL

1. To turn the unit on, turn the switch to the on position.
  - Power is sent to primary side of the 120vac/16vac transformer.
  - Power is sent to the normally closed high limit.
  - From the high limit power is sent to the normally open contacts of the 12VDC relay and the L1 and L2 terminals of the ignition module.
2. From the secondary of the transformer 16VAC is sent to the controller.
  - Power is sent to the red LED (low water indicator light) from terminal 4 of the controller.
  - If the water probe is grounded through water the LED will go off.
  - If the water probe is not grounded the LED will remain on and the unit will not heat.
  - If the resistance of the thermistor is higher than the setting of the potentiometer( the unit is calling for heat) then 16VDC is sent to the coil of the relay and the green LED (heat indicator light)
  - The 12VDC relay will close until the unit reaches temperature
3. With the contacts of the relay closed, 120VAC is sent to the blower and primary coil of the 120VAC/24VAC transformer.
  - From the secondary of the 24VAC transformer power is sent to the normally open contacts of the air switch.
  - When the air from the blower closes the air switch, 24VAC is sent to the Th terminal of the ignition module.
4. With both 120VAC (at L1 and L2) and 24VAC (at Gnd and Th) to the ignition module then 120VAC will be sent to the surface igniter.
5. After the ignition module has been energized for 24 seconds the module will send 24VAC to the gas valve.
  - The gas will touch the hot igniter and ignite.
  - The kettle will build pressure until the controller is satisfied by the thermistor at the setting of the potentiometer.
  - The controller will then turn off the heat circuit until the temperature of the kettle is below the setting

# TROUBLESHOOTING GUIDES (Legend)

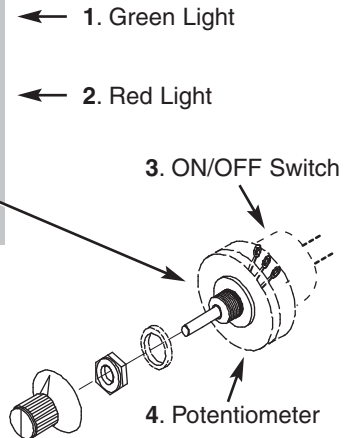
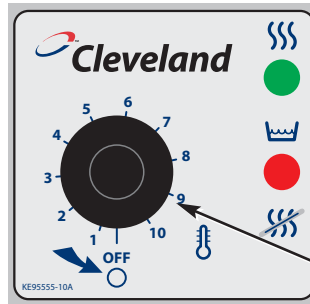

5. Kettle Jacket Water Sight Glass

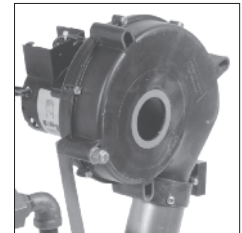
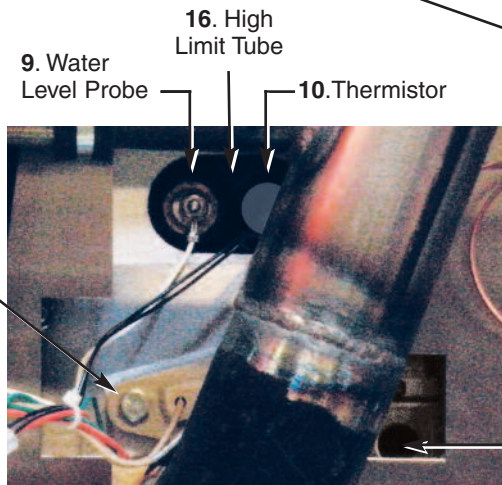

- 1. Green Light
- 2. Red Light
- 3. ON/OFF Switch
- 4. Potentiometer
- 5. Kettle Jacket Water Sight Glass
- 6. Pressure Gauge
- 7. Gas Valve
- 8. Blower
- 9. Water Level Probe
- 10. Thermistor
- 11. Ignitor
- 12. Sight Glass
- 13. 14V Transformer
- 14. 24V Igniton Transformer
- 15. SSK Controller
- 16. High Limit
- 17. Ignition Module
- 18. Relay
- 19. Air Switch

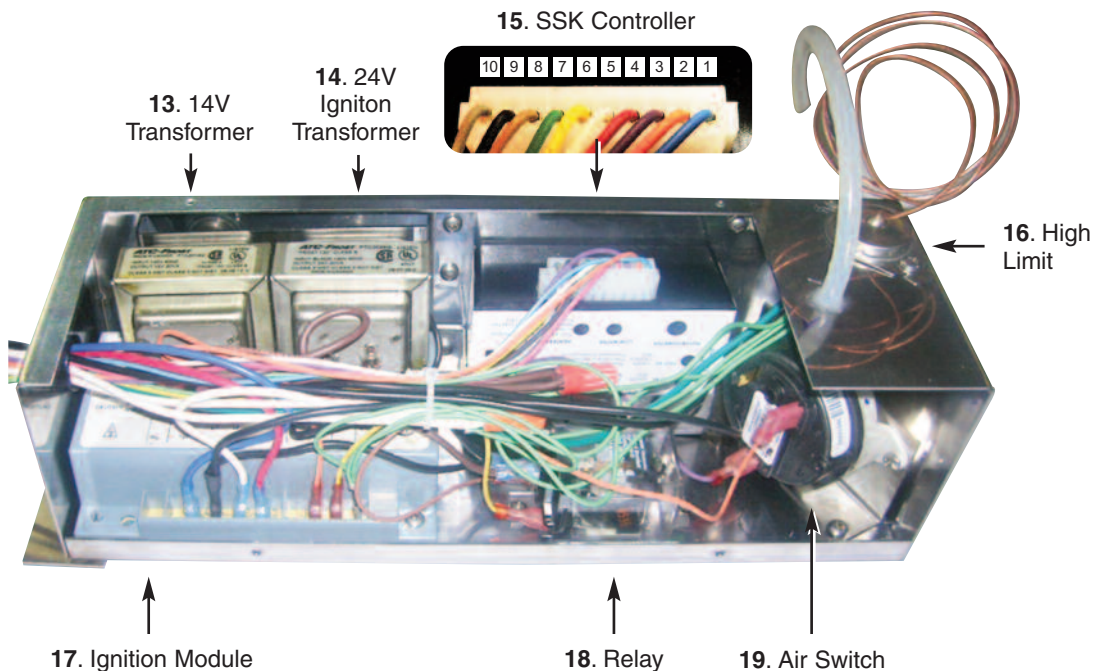
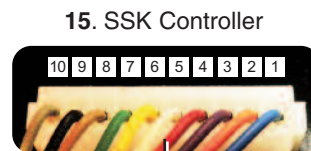

# TROUBLESHOOTING GUIDES (continued)

**PROBLEM:**  
**KGL**  
**Kettle Won't Heat**

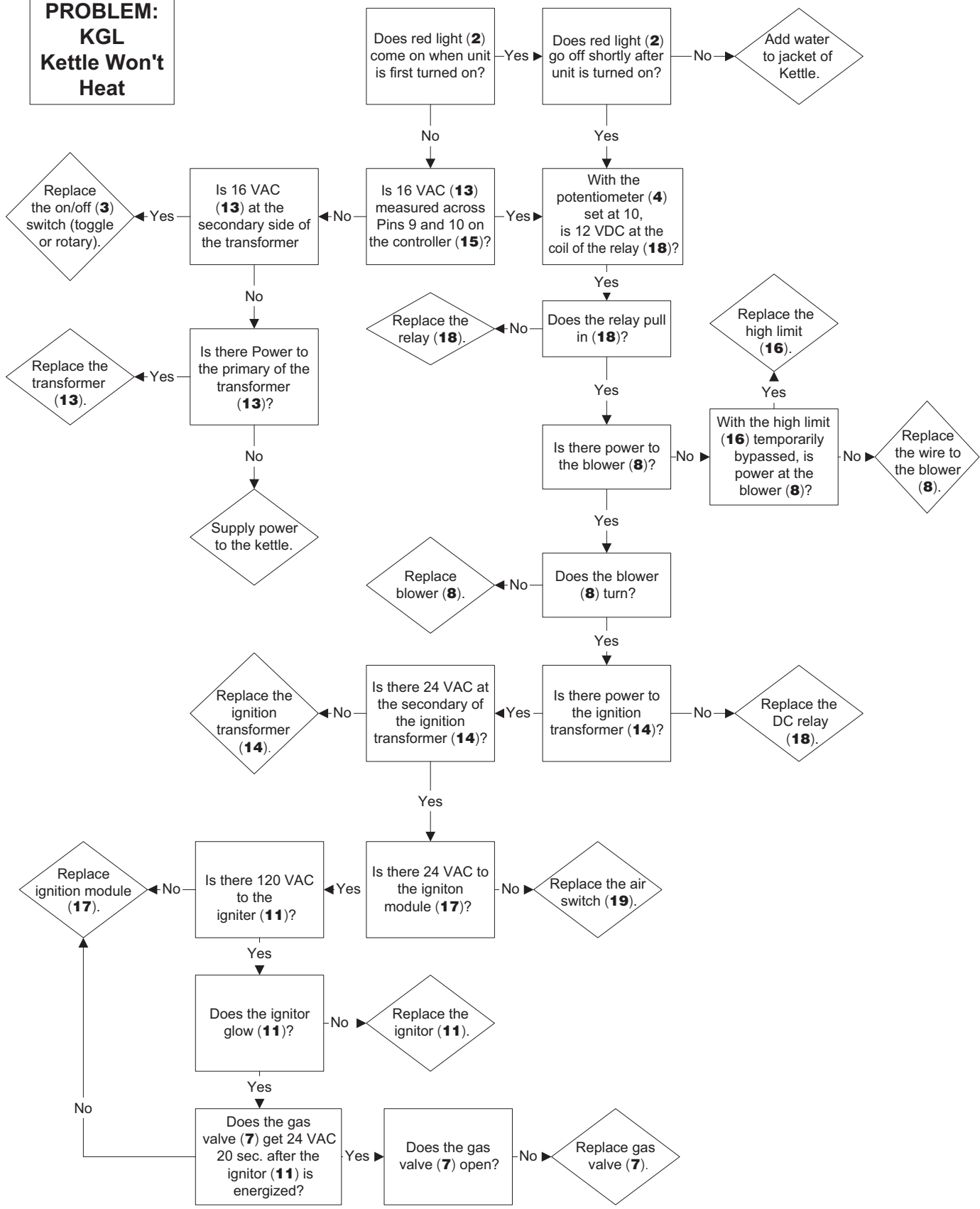

# TROUBLESHOOTING GUIDES (continued)

**PROBLEM:  
KGL  
Kettle Not  
Hot Enough**

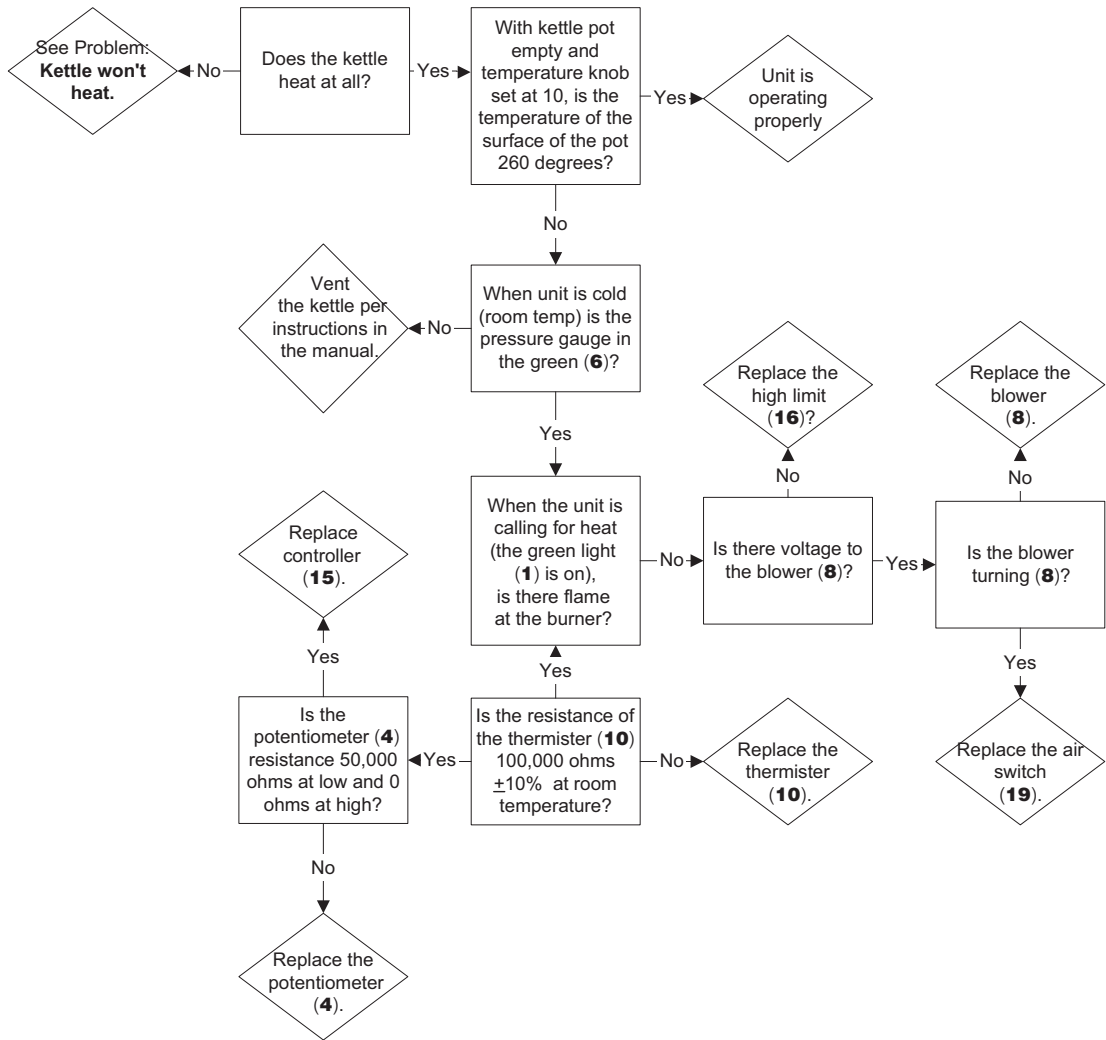

## PROBLEM: KGL Kettle Has Delayed Ignition

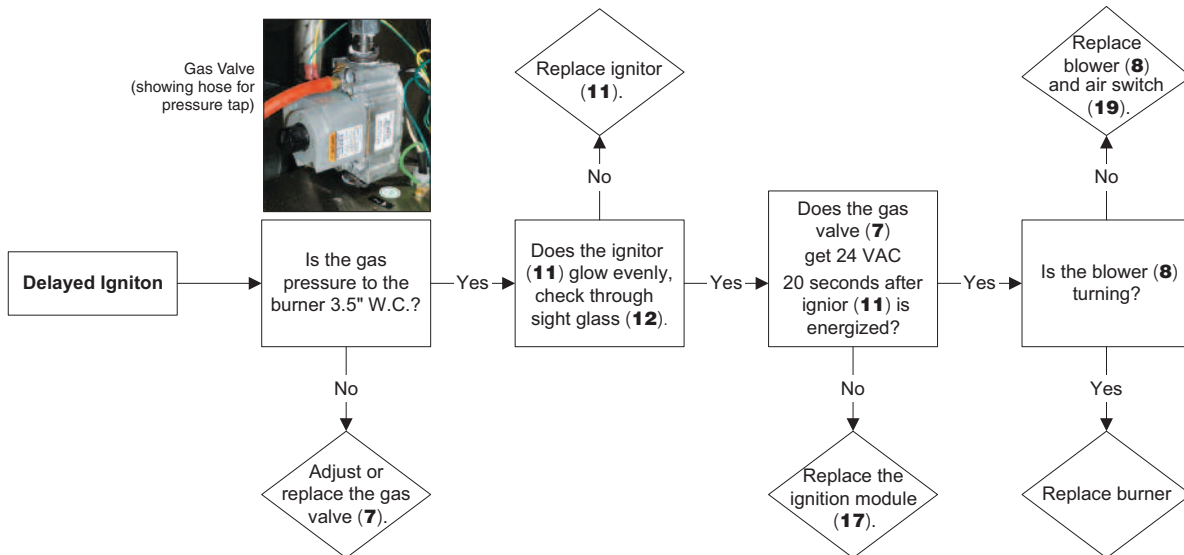

# TROUBLESHOOTING GUIDES (continued)

**PROBLEM:**  
KGL Kettle  
Gets Too  
Hot

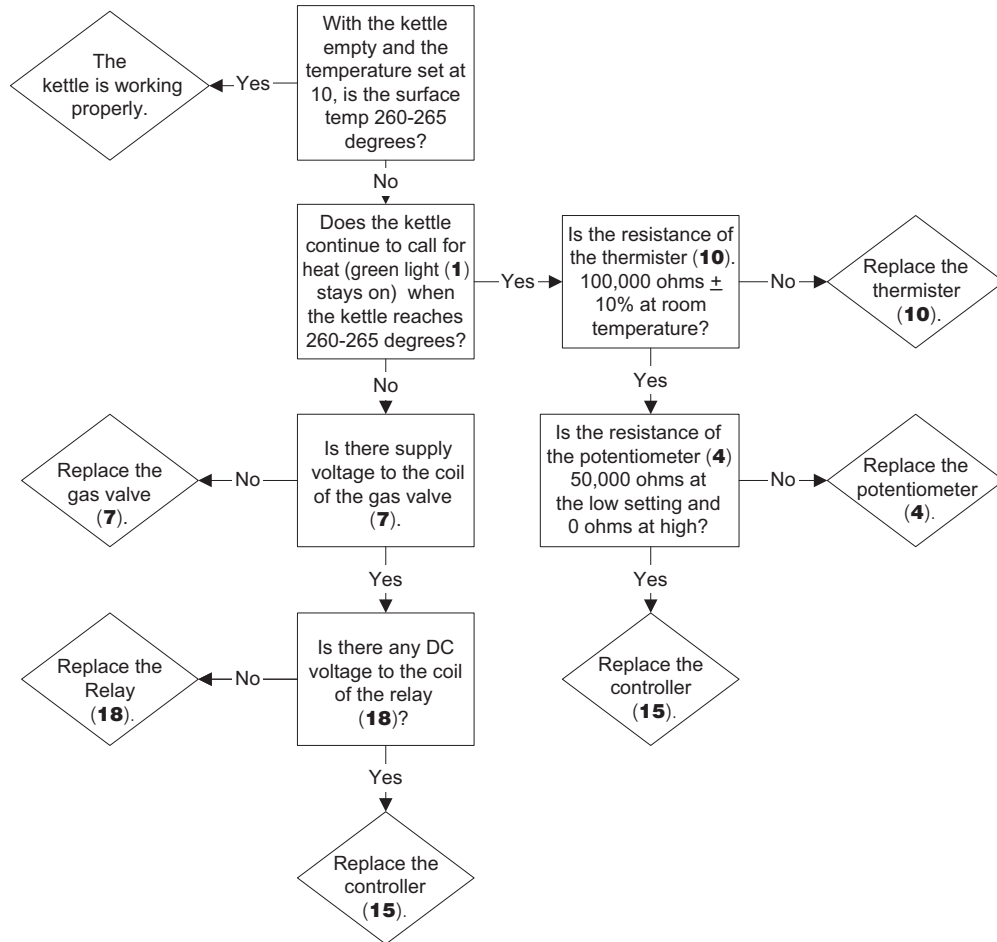

**PROBLEM: Red Add Water LED Stays On**

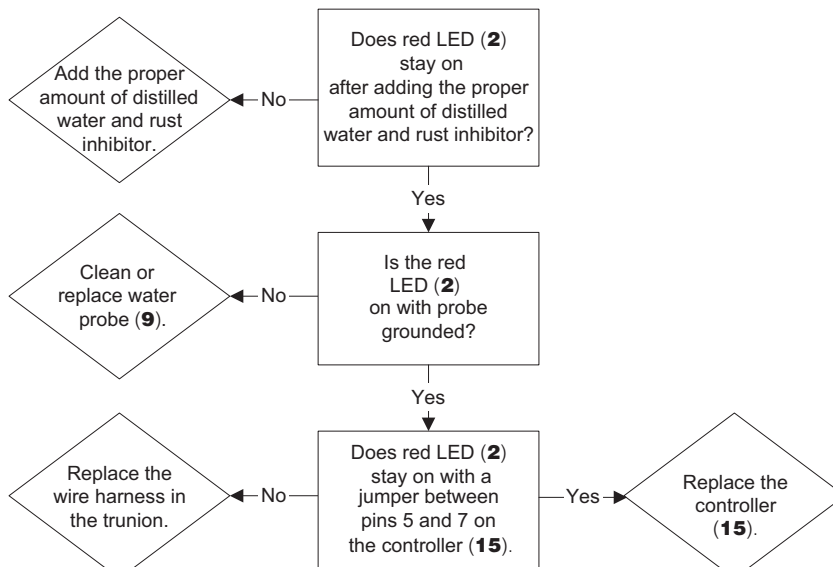

# KETTLE SAFETY INSPECTION AND TESTING

## SAFETY VALVE INSTALLATION:

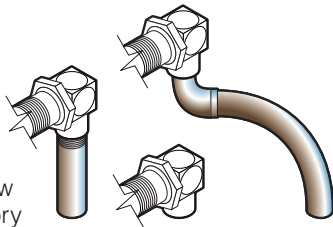

The above illustrations show the three variations of factory installed Safety Valves.

**Modifications are unacceptable.**

## SAFETY THERMOSTAT:

### Correct Installation

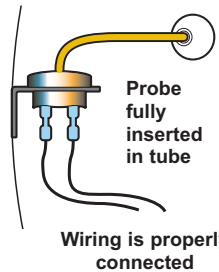

### Incorrect Installations

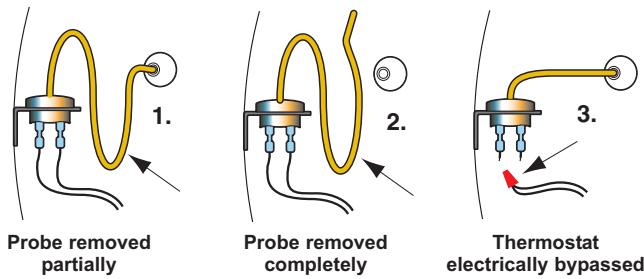

1. Safety thermostat probe is not completely inserted into tubing.
2. Safety thermostat probe is removed from tubing.
3. Safety thermostat electrical connection is bypassed.

## OPERATING THERMOSTAT:

If maximum temperature is not in this range (on empty kettle), refer to the "Calibrating Procedure".

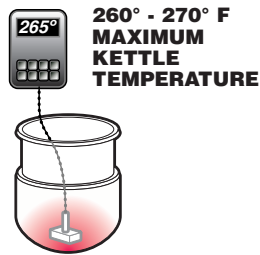

## GAS KETTLE AIR SWITCH:

### Correct

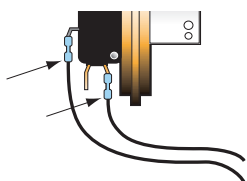

Wiring is properly connected

### Incorrect

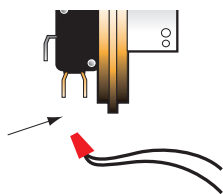

Switch electrically bypassed

## LOW WATER LEVEL PROBE:

Probe properly attached ✓

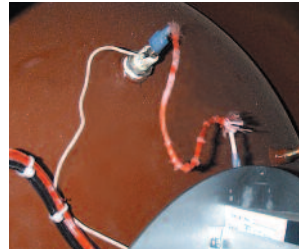
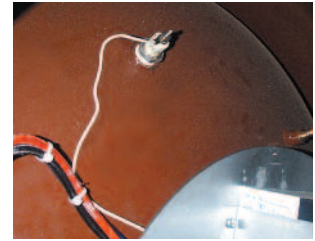

✗ Probe bypassed by running (A) an additional wire

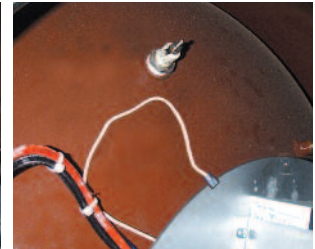

✗ Probe bypassed by (B) grounding the connecting wire

## PRESSURE RELIEF VALVE TESTING

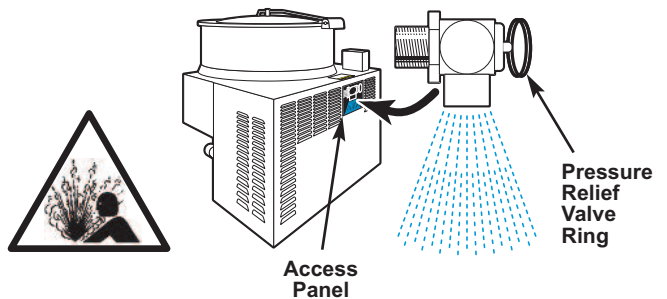

**WARNING:** Use of gloves and eye protection to prevent personal injury.

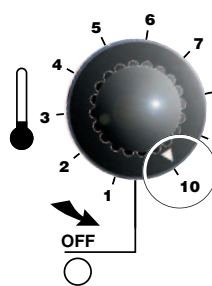

1. With the kettle empty, set On-Off Switch/Temperature Control to "10" (Max.). Allow the kettle to heat until the unit cycles off.
2. Switch On-Off Switch/Temperature Control to "0" (Off) and disconnect main power at fused disconnect switch.
3. Remove Access Panel at back of main kettle console.
4. Pull Pressure Relief Valve Ring open for a maximum of one second. Repeat test three to four times. Each time the mechanism should move freely and be accompanied by a rapid escape of steam.
5. Replace access panel.

### IMPORTANT:

If valve appears to be sticking replace pressure relief valve.

If foreign material is discharged then drain kettle and replace pressure relief valve.

# CALIBRATING PROCEDURE

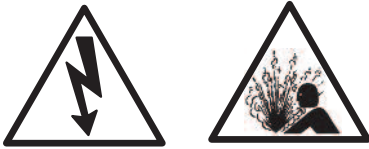
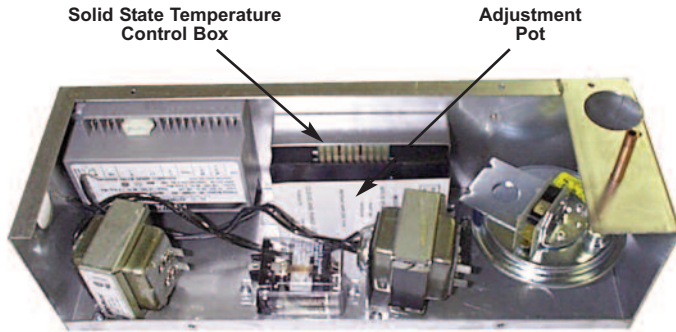

1. Insure the unit has a vacuum before you begin calibrating procedures. If unit requires venting refer to KETTLE VENTING INSTRUCTIONS.
2. Set On-Off Switch/Temperature Control to "10" (Max.).
3. Allow the unit to cycle twice.
4. Check temperature of the inner kettle surface with a digital surface thermometer.
5. Temperature should be between 260°F and 265°F.

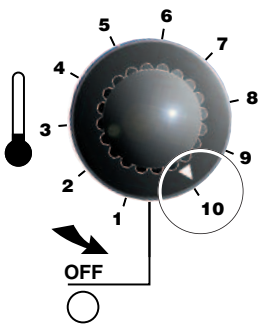

6. Using a screw driver adjust temperature by turning the potentiometer on the Solid State Temperature Control Box. Turn very little. Turn clockwise to INCREASES and counter-clockwise to DECREASE temperature.
7. Allow the unit to cycle twice.
8. Check temperature of the inner kettle surface with a digital surface thermometer.

9. Repeat steps 4. through 8. until unit is calibrated.

# FREE AIR CALCULATION

Insert drager pump tube 4" down the center of the flue and take one sample each of Carbon Dioxide (CO<sub>2</sub>) and Carbon Monoxide (CO) and record results.

\_\_\_\_\_ % CO  
\_\_\_\_\_ (PPM)

With results obtained for CO<sub>2</sub> use chart to determine dilution factor for gas type used.

\_\_\_\_\_ Dilution Factor

Enter these numbers in the following formula to determine the concentration of carbon monoxide in an air free sample of flue gas.

$$\text{Dilution Factor} \times \frac{\text{CO (PPM)}}{10,000} = \frac{\text{_____}}{\% \text{ Carbon Monoxide}}$$

Result must not exceed 0.08% carbon monoxide.

CARBON DIOXIDE IN SAMPLE (PERCENT)	FACTOR PROPANE GAS	FACTOR NATURAL GAS
4.0	3.50	3.05
4.2	3.33	2.90
4.4	3.18	2.77
4.6	3.04	2.65
4.8	2.92	2.54
5.0	2.80	2.44
5.2	2.69	2.34
5.4	2.59	2.26
5.6	2.50	2.18
5.8	2.41	2.10
6.0	2.33	2.03
6.2	2.26	1.97
6.4	2.19	1.91
6.6	2.12	1.85
6.8	2.06	1.80
7.0	2.00	1.74
7.2	1.94	1.70
7.4	1.89	1.65
7.6	1.84	1.61
7.8	1.79	1.56
8.0	1.75	1.53
8.2	1.71	1.49
8.4	1.67	1.45
8.6	1.63	1.42
8.8	1.59	1.39
9.0	1.56	1.36
9.2	1.52	1.33
9.4	1.49	1.30
9.6	1.46	1.27
9.8	1.43	1.24
10.0	1.40	1.22

## KETTLE VENTING INSTRUCTIONS

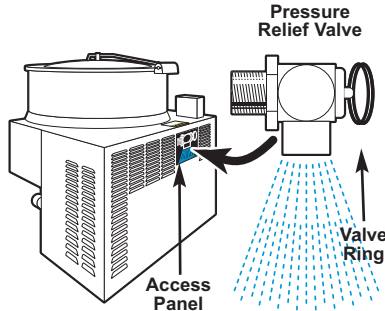
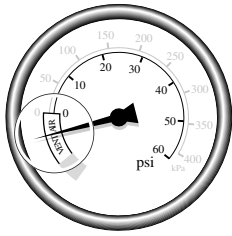
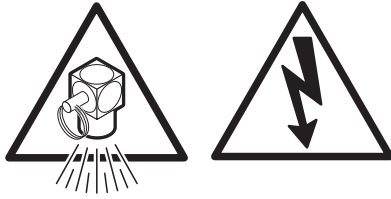

The following venting procedure should be followed when the Vacuum/Pressure Gauge needle is in the "VENT AIR" zone:

**NOTE:** Check for and eliminate leaks prior to venting (see REPAIRING LEAKS IN STEAM JACKETED KETTLE FITTINGS).

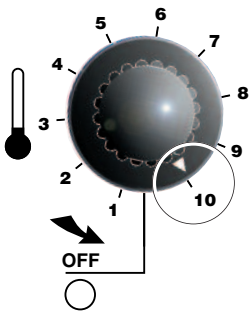

1. Remove Access Panel from back of main kettle console.
2. Turn kettle ON and set temperature control to **10**, heat the empty kettle until unit cycles off.
3. Vent kettle by pulling Valve Ring eight to fifteen times, holding valve open for two seconds each time.

**NOTE:** If unit cycles ON, stop venting and wait for kettle to cycle OFF before continuing.

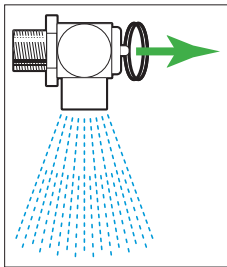

4. Turn kettle OFF. Add cold water to kettle until its surface temperature is below 100°F. The pressure gauge needle should be in the green zone, indicating a vacuum in the kettle's jacket.

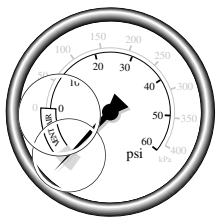

5. If needle is in the green zone then venting was successful. If not repeat procedure.

## REPAIRING LEAKS IN STEAM JACKETED KETTLE FITTINGS

If unit will not hold a vacuum the most likely cause is a leak at one of the fittings.

Often, the easiest way to eliminate a leak is reseal the suspect areas.

1. Water Level Probe  
Remove, clean threads, apply teflon thread sealant and reinstall.
2. Pressure Relief Valve  
**A/** Inspect for signs of leaks. Replace if required.  
**B/** Remove, clean threads, apply teflon thread sealant and reinstall.
3. Pressure Gauge  
**A/** Inspect face of gauge. If it contains moisture on the inside of face replace.  
**B/** Check tightness of plumbing connection to pressure Gauge.
3. Sight Glass  
**A/** Check tightness of sight glass.  
**B/** Replace "O" ring if required.

## LUBRICATION PROCEDURE

Lubricate the following parts every three months to insure smooth operation and reduce wear.

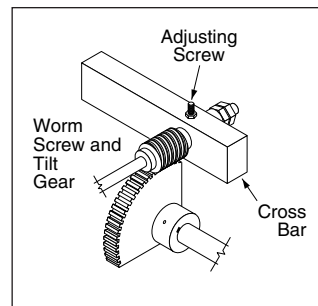

### TRUNNION HOUSING, WORM SCREW AND TILT GEAR

These parts are accessed through the top cover of the console.

Apply grease to gear teeth. Check for excessive play and adjust with adjusting screw located on top of cross bar.

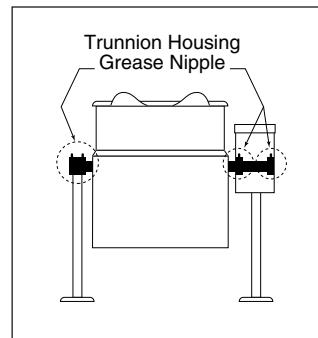

### KETTLE TRUNNIONS

On the left hand side of the kettle there are two grease nipples on the top back portion of the trunnion housing. On the right hand side of the kettle you must remove the console cover to access the two grease nipples.

## RESERVOIR FILL PROCEDURES



**WARNING:**  
IMPROPER REFILLING OF KETTLE  
JACKET WILL RESULT IN  
IRREVERSIBLE DAMAGE TO UNIT.

The kettle's water level must be maintained at the proper level. Under normal operating conditions, the sealed water reservoir should never require the addition of water.

If the red "low water" light comes on during use (while the kettle is in an upright position), the water level has reached a critically low level. The low water protection control has automatically shut off the gas burner. The following procedure must be completed before further use:

**NOTE:** Have a qualified service technician repair the leakage problem and add water to the unit. Ensure that the red "low water" light is on when the kettle is upright. On tilting kettles, it is normal for the red light to come on when the kettle is in a tilted position.

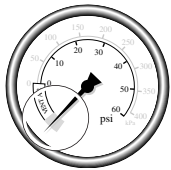
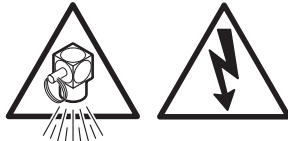

1. Ensure kettle is at room temperature and pressure gauge showing zero or less pressure.
2. Shut off power to the kettle at the fused disconnect switch.

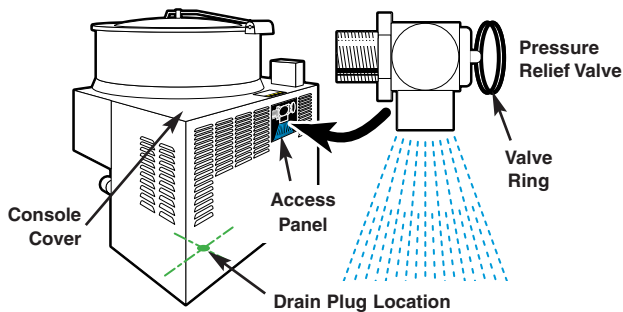

3. Remove Console Cover and Access Panel.

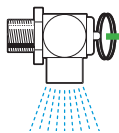

**Important-**  
Pull ring on Pressure Relief Valve prior to removal to insure vessel is not pressurized.

4. Pull Pressure Relief Valve Ring open to insure vessel is not pressurized.
5. Remove 1/4" copper tubing and reducer bushing.
6. Add distilled water using a funnel if necessary. Fill the unit to the high level mark on the Sight Glass.
7. Apply a thread sealant (i.e. Teflon tape) to the reducer bushing threads and replace.
8. Replace Console Cover and Access Panel.
9. Restore power to unit at the fused disconnect switch.



**Sight Glass**

10. The kettle must now be vented. (Refer to the KETTLE VENTING INSTRUCTIONS).

## HINGE ADJUSTMENT INSTRUCTIONS

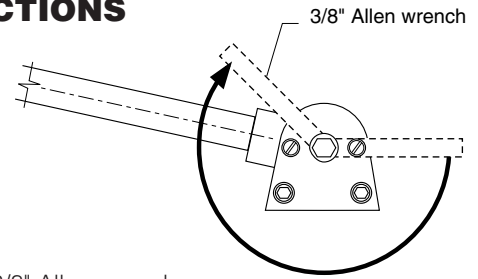

1. Insert 3/8" Allen wrench.
2. Turn clockwise to relieve tension on spring.
3. While tension is released remove one of the two slotted screws.
4. To prevent Allen wrench from springing back abruptly while the second slotted screw is removed, insert a pin (approximately 1/8") in the hole where the first slotted screw was removed from.
5. Remove second slotted screw.
6. While holding Allen wrench remove pin.
7. Turn Allen wrench clockwise to tighten or counter-clockwise to loosen tension to produce desired effect.
8. Re-insert pin in one of the two holes.
9. Tighten one slotted screw in the other hole (it may be necessary to turn Allen wrench slightly to align holes).
10. Remove pin and repeat step number 9 for other slotted screw.

FI00196 1/2 galv cap

# KETTLE JACKET CLEANOUT AND PASSIVATION PROCEDURES

The following procedure should be performed at least once every three years to prevent possible corrosion and ensure the optimum life of the kettle.

## RUST INHIBITOR

Use a “radiator rust inhibitor” that can be purchased at your local automotive centre. It should not contain any anti-freeze and preferably no lubricant.

To ensure satisfactory mixing follow the manufacturer’s instructions.

DISPOSAL - Follow all Federal, State and local codes when disposing of product.



**DANGER:**  
RUST INHIBITOR CAN BE DANGEROUS.  
READ LABEL AND FOLLOW SAFETY  
INSTRUCTIONS.



**WARNING:**  
IMPROPER REFILLING OF KETTLE  
JACKET WILL RESULT IN  
IRREVERSIBLE DAMAGE TO UNIT.

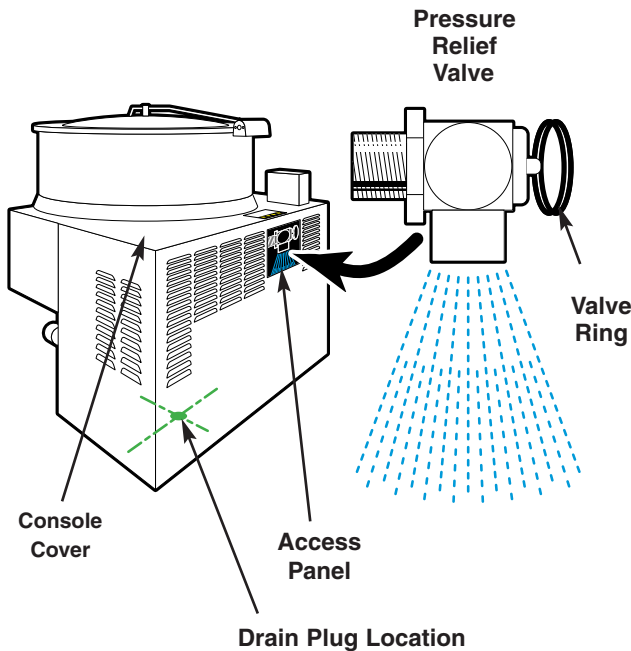

## PROCEDURE

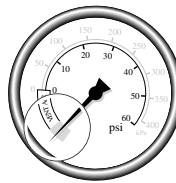

1. Ensure kettle is at room temperature and pressure gauge showing zero or less pressure.
2. Shut off and disconnect gas supply.
3. Remove electrical plug from power source.
4. Remove bolts holding kettle to tabletop.
5. Pull ring on pressure relief valve to insure there is no pressure within the kettle jacket.
6. Remove pressure relief valve.
7. Replace pressure relief valve with street elbow (see above illustration).
8. Remove sight glass from left side of kettle.
9. Tilt kettle on its side (sight glass opening facing downwards) and allow to drain. Flush out with water.
10. Tilt kettle upright, apply a thread sealant (i.e. Teflon tape) to the sight glass threads and replace.
11. Refer to chart below to determine the required volume of water.

Kettle Size	Volume of Mixture	
	U.S. Gal.	Liters
6 U.S. Gal.	1.6	5.8
12 U.S. Gal.	2.2	8.3

12. In a separate container mix water with the required rust inhibitor.
13. Fill jacket via the street elbow with the mixture.
14. Remove street elbow.
15. Apply a thread sealant (i.e. Teflon tape) to the pressure relief valve and replace.
16. Reconnect gas and electrical supplies.
17. Turn kettle on, vent and heat to high for 1/2 hour.
18. Cool kettle.
19. Repeat steps 5-15.
20. Replace bolts holding kettle to tabletop.
21. Reconnect gas and electrical supplies.
22. Turn kettle on and vent kettle.

# NATURAL GAS TO PROPANE CONVERSION KIT

For KGL Floor Model Gas Kettles (except KGL-25/T)



**UNIT EXHAUST CONTAINS CARBON MONOXIDE.  
OPERATE ONLY UNDER A PROPERLY FUNCTIONING  
HOOD WITH ADEQUATE MAKEUP AIR.**

THIS CONVERSION KIT SHALL ONLY BE INSTALLED BY A  
QUALIFIED SERVICE AGENCY

For use at 0-2000 feet elevation on Honeywell valves Model  
8305. For higher elevations consult the factory.

## Conversion Parts Required

KGL-40 (Kit Service #KE003716-5)

Part No.	Description	Quantity
KE603911-5	Conversion Label	1
KE53403-5	Gas Orifice	1
FA05002-29	"O" Ring	1

KGL-60 to 100 (Kit Service #KE003716-4)

Part No.	Description	Quantity
KE603911-4	Conversion Label	1
KE53403-7	Gas Orifice	1
FA05002-29	"O" Ring	1
KE603910-3	Instruction Seet	1

Air Intake Washer (KE54420-1) is required for 50Hz units - see conversion kits  
KE003716-6 & KE003716-7.

### WARNING

This conversion kit shall be installed by a qualified service agency in accordance with the manufacturer's instructions and all applicable codes and requirements of the authority having jurisdiction. If the information in these instructions is not followed exactly, a fire, and explosion or production of carbon monoxide may result causing property damage, personal injury or loss of life. The qualified service agency is responsible for the proper installation of this kit. The installation is not proper and complete until the operation of the converted appliance is checked as specified in the manufacturer's instructions supplied with the kit.

### CAUTION

The gas supply shall be shut off prior to disconnecting the electrical power, before proceeding with the conversion.

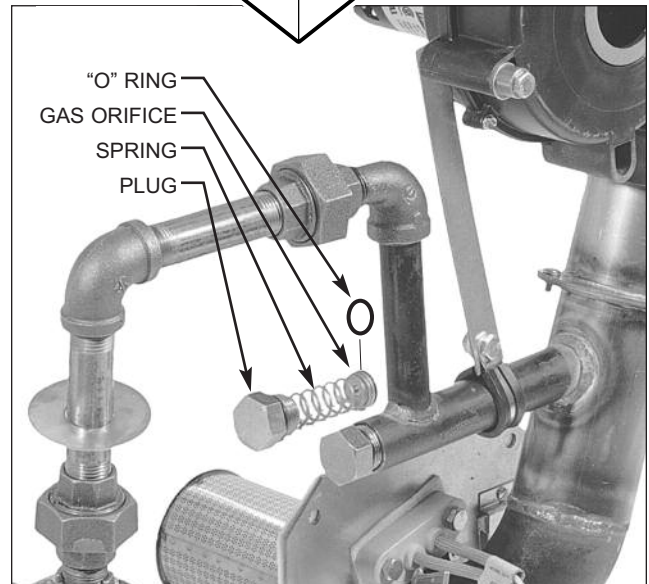
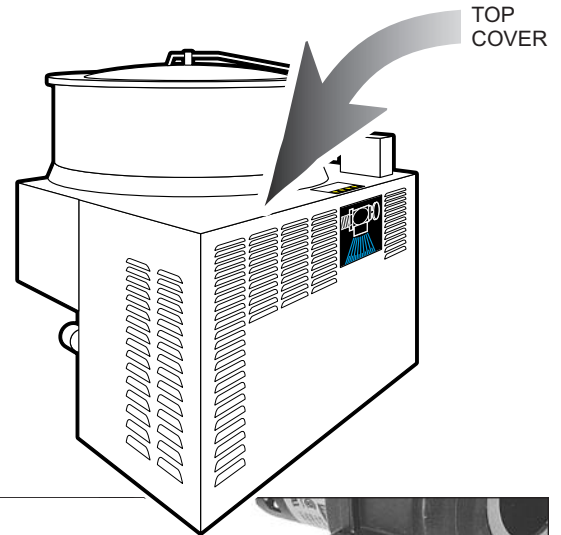

## INSTRUCTIONS

**NOTE:** Use thread sealant compatible with propane gas on all threaded piping connections.

1. Disconnect electrical connection.
2. Shut off main gas supply and disconnect kettle from supply line.
3. Remove **TOP COVER**.
4. Remove **PLUG** and **SPRING**.
5. Remove **GAS ORIFICE** and **"O" RING**.
6. Replace with new **GAS ORIFICE** and **"O" RING**.
7. Replace **SPRING** and **PLUG**.
8. Replace **TOP COVER**.
9. Check inlet pressure is between 12-14 inches W.C.
10. Check input rate of unit.
11. On the underside of the console cover with indelible marker place the following information: Company, Name, Address & Date of Conversion.
12. Replace **TOP COVER**.
13. Place gas conversion label next to rating label.
14. Reconnect electrical and gas supplies.

# SERVICE PARTS

## WARRANTY

Our Company supports a worldwide network of Maintenance and Repair Centers. Contact your nearest Maintenance and Repair Centre for replacement parts, service, or information regarding the proper maintenance and repair of your cooking equipment.

In order to preserve the various agency safety certification (UL, NSF, ASME/Ntl. Bd., etc.), only factory-supplied replacement parts should be used. The use of other than factory supplied replacement parts will void warranty.

## FAUCET ASSEMBLY

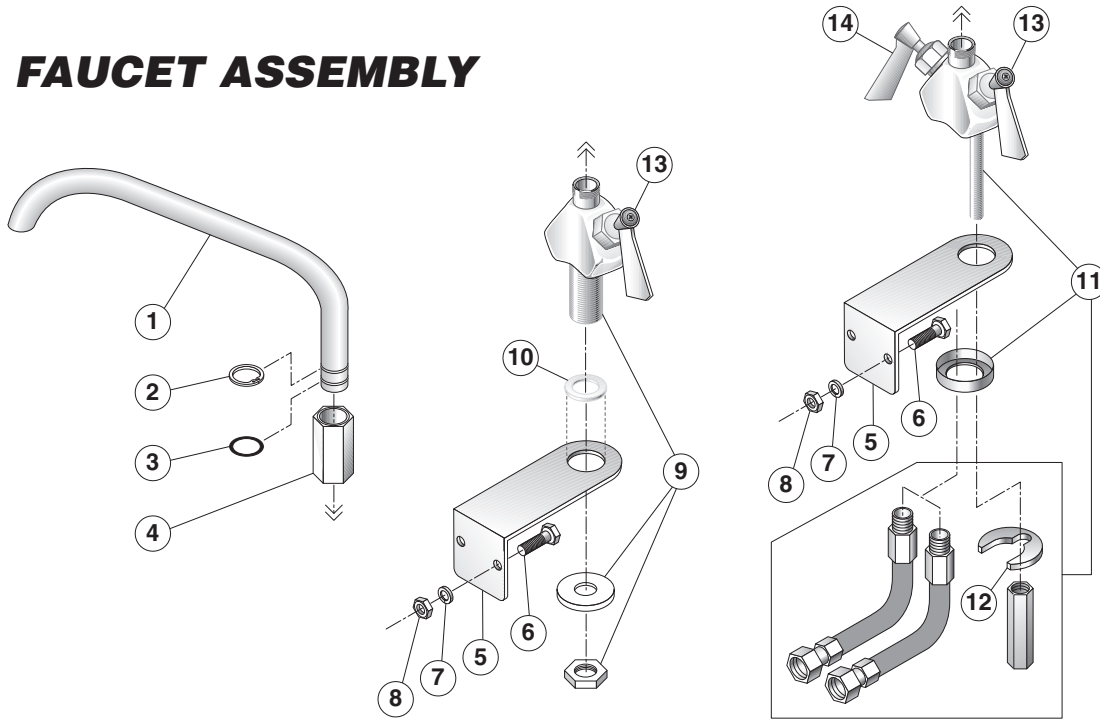

ITEM #	PART #	DESCRIPTION	QTY.
	<b>SPK2</b>	<b>SINGLE PANTRY FAUCET</b> for <u>KGL60/80T</u> (includes items 1-10)	
	<b>DPK2</b>	<b>DOUBLE PANTRY FAUCET</b> for <u>KGL60/80T</u> (includes items 1-8 & 11)	
	<b>SPK3</b>	<b>SINGLE PANTRY FAUCET</b> for <u>KGL40T</u> & <u>KGL40TSH</u> (includes items 1-10)	
	<b>DPK3</b>	<b>DOUBLE PANTRY FAUCET</b> for <u>KGL40T</u> & <u>KGL40TSH</u> (includes items 1-8 & 11)	
	<b>SPK5</b>	<b>SINGLE PANTRY FAUCET</b> for <u>Stationary Kettles</u> (includes items 1-10)	
	<b>DPK5</b>	<b>DOUBLE PANTRY FAUCET</b> for <u>Stationary Kettles</u> (includes items 1-8 & 11)	
1.	KE50825-2	3/4" SPOUT for - <u>SPK2</u> & <u>DPK2</u> .....	1
	KE50825-3	3/4" SPOUT for - <u>SPK3</u> & <u>DPK3</u> .....	1
	KE50825-5	3/4" SPOUT for - <u>SPK5</u> & <u>DPK5</u> .....	1
2.	FA95007-10	RETAINING RING .....	1
3.	FA05002-19	"O" RING .....	1
4.	KE51736	LONG FAUCET NUT .....	1
5.	KE54159	FAUCET MOUNTING BRACKET for <u>Tilting Kettles</u> .....	1
6.	FA11258	HEX CAP SCREW .....	2
7.	FA31029	LOCK WASHER .....	2
8.	FA210028	HEX NUT .....	2
9.	KE51401	SINGLE PANTRY BODY (c/w item 13) .....	1
10.	KE50335	ADAPTER WASHER .....	1
11.	KE51403	DOUBLE PANTRY BODY (c/w item 13 & 14) .....	1
12.	SE50447	REPLACEMENT HORSESHOE WASHER .....	1
13.	SE50021	REPLACEMENT STEM ASSEMBLY, COLD WATER .....	1
14.	SE50020	REPLACEMENT STEM ASSEMBLY, HOT WATER .....	1

# CONSOLE CONTROLS

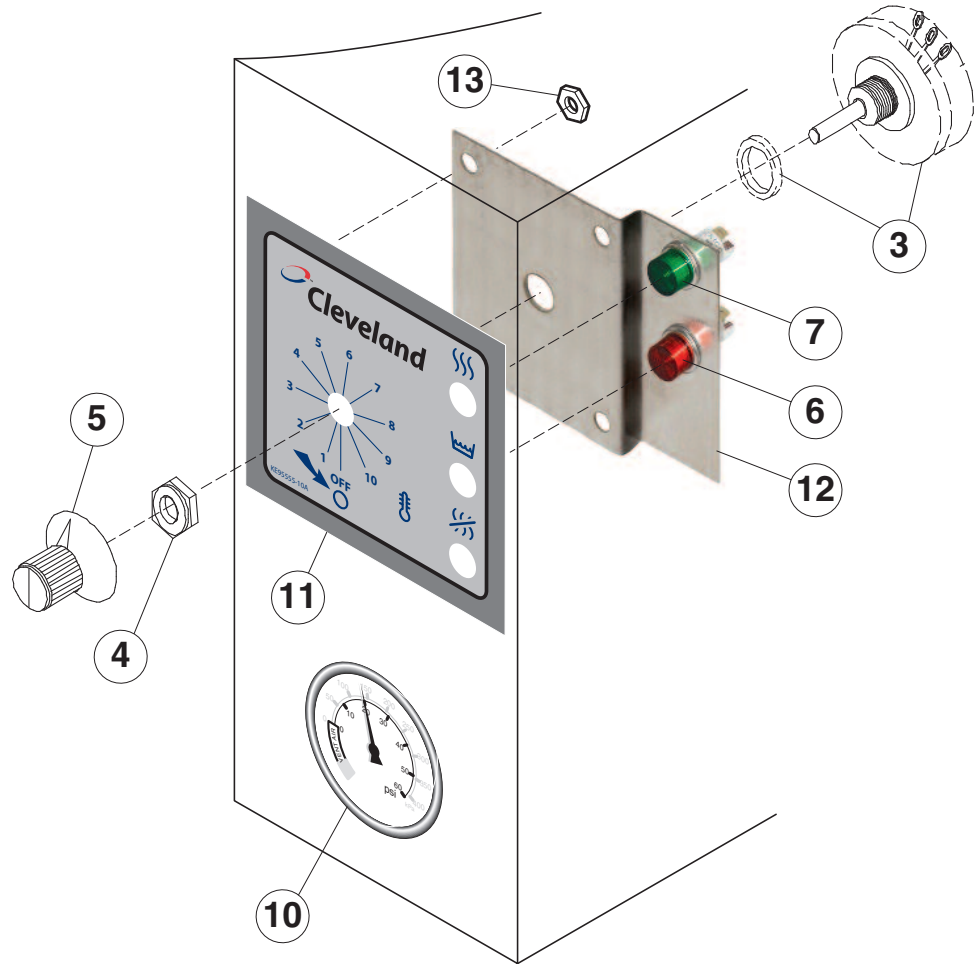

ITEM NO.	PART NO.	DESCRIPTION	QTY.
3.	SE00114	POTENTIOMETER WITH ON/OFF SWITCH, C/W ITEM #4	1
4.	KE51005	RUBBER BOOT	1
5.	KE50569-1	KNOB, POTENTIOMETER	1
6.	KE55486-2	INDICATOR LIGHT, RED	1
7.	KE55486-3	INDICATOR LIGHT, GREEN	1
10.	KE50429-6	PRESSURE GAUGE	1
11.	KE95555-10	LABEL	1
12.	KE603836	BRACKET, LIGHT	1
13.	FA21006	#10-24, HEX NUT, S.S.	4

# SIGHT GLASS

ITEM ON.	PART NO.	DESCRIPTION	QTY.
1.	KE50955	RETAINING COVER	1
2.	KE52871	GASKET	1
3.	KE51053	SIGHT GLASS	1
4.	FA05002-30	"O" RING	1

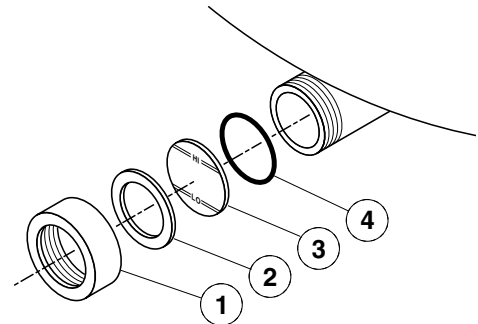

# ELECTRICAL COMPONENT BOX - 115 VOLT UNITS

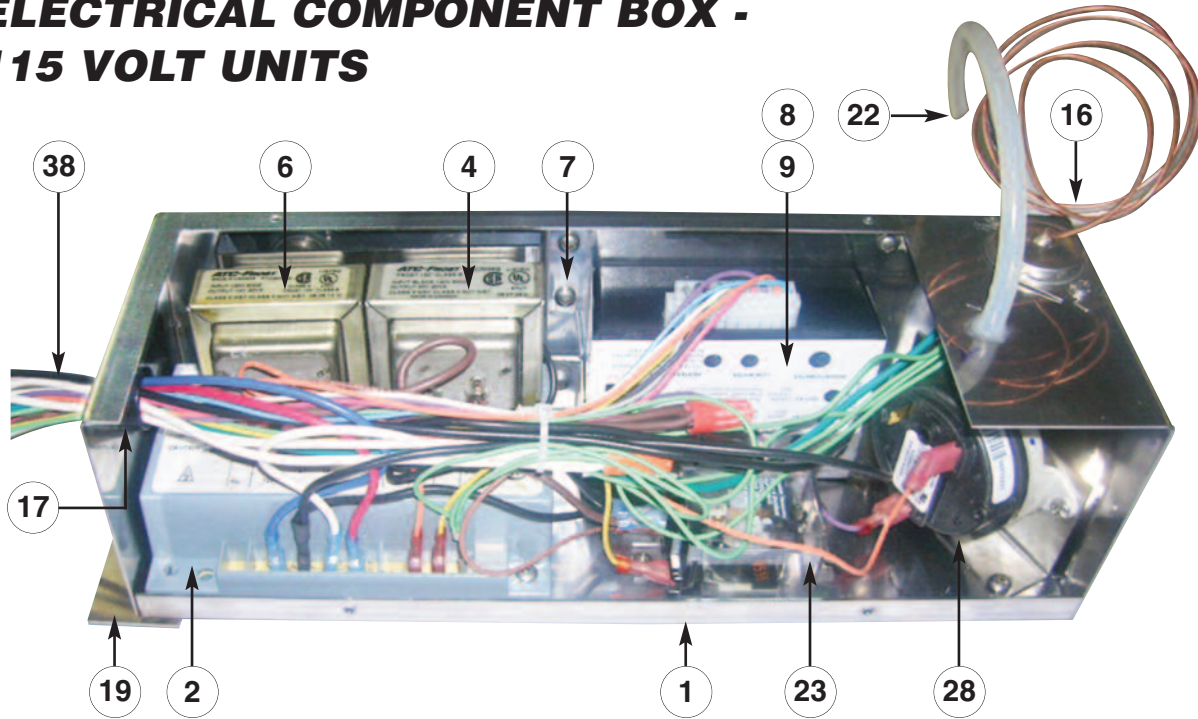

ITEM	PART #	DESCRIPTION	QTY.
1	KE003654	COMPONENT BOX WELDMENT; KGL/-T	1
2	KE53469-5	IGNITION CONTROL; KGL/T (CSA/CE/AGA APPROVED)	1
4	KE53838-20	TRANSFORMER;120 V PRIMARY/24 V SECONDARY60HZ, 20 VA	1
6	KE53838-27	TRANSFORMER;120 V PRIMARY/14 V SECONDARY60HZ, 20 VA	1
7	KE603765	TRANSFORMER BRACKET	1
8	KE00458-1	KETTLE CONTROL BOX	1
9	KE50303-1	ELECTRONIC BOX HOLDER	1
10	KE53599-1	GASKET; KGL/KGL-T	1
16	KE55069-6	THERMOSTAT;SAFETY(KGT/KGL)	1
17	KE54833-3	SNAP-IN BUSHING; 0.875 DIA.	1
18	KE53440	COVER; COMPONENT BOX (KGL/-T)	1
19	KE53620	BRACKET FOR COMPONENT BOX	1
22	KE55501-1	TUBE; AIR SWITCH	1
23	KE50753-7	RELAY; SPDT/10A/12VDC #MJN1CF-DC12	1
24	FA15018-4	SCREW; PHILIPS 8-32X3/8"L	4
25	FA15018-3	SCREW; PHILIPS 8-32X1/4"L	6
26	FA10243	SCREW; SLOT 8-32X3/4"L	2
27	FA15018-7	SCREW; PHILIPS 6-32X1/4"L	2
28	KE02400-1	AIR PRESSURE SWITCH ASSEMBLY; DOMESTIC AND CE	1
29	KE54662-1	HEAT SHRINKABLE TUBING; 3/16 ID 12" LONG	1
30	KE54661-2	VARFLO SLEEVING 12" LONG	1
31	NPN00163	CONNECTOR; MARR NO. 2	1
32	KE54668-1	TERMINAL; FULLY INSULATED AMP#2-520181-2 OR 182-2	2
33	KE50988-1	POTENTIOMETER; C/W ON/OFF SW REV LOG TAPER	1
34	KE50567-1	LIGHT; RED-WATER INDICAT #249-7867-3331-504	1
35	KE50567-3	LIGHT; GREEN-HEAT INDICAT #249-7967-3332-504	1
36	KE51005	ROTARY SEAL; #N9030 X 1/4 (AMP-HEXSEAL)	1
37	KE52412	CONNECTOR; MARR NO. 1	2
38	WHKGLT	WIRING HARNESS; KGL40-100	1

Items #10, 18, 24-27, 29-37 not show for clarity.

Partspin®



### Cleveland KE53440 COVER COMP BOX (KGL/-T)

List Price **\$75.29**

- 1 +

Quantity Available: **4**

Manufacturer: [Cleveland](#)

Manufacturer #: **KE53440**

Parts Town Part #: **CLEKE53440**

Units: **Each**

Fits Models: [View Models List](#)

California Residents: [Proposition 65 Warning](#)

**Ship It!**

Ships today from  
if ordered in the s  
**My Price: \$:**

[Log in to enable Q:](#)

[Share this Pr](#)

# GAS CONTROL ASSEMBLY

## 19 GAS ORIFICES

	NATURAL GAS	PROPANE GAS
Sea level up to 2,000', 40 gal.	KE53403-8	KE53403-5
Sea level up to 2,000', 60 - 100 gal.	KE53403-6	KE53403-7
2000' up to 4,000', 40 gal.	KE53403-8	KE53403-9
2000' up to 6,000', 60 - 100 gal.	KE53403-10	KE53403-11
4000' up to 6,000', 40 gal.	KE53403-12	KE53403-13
4000' up to 6,000', 60 - 100 gal.	KE53403-10	KE53403-14

### Stationary Models

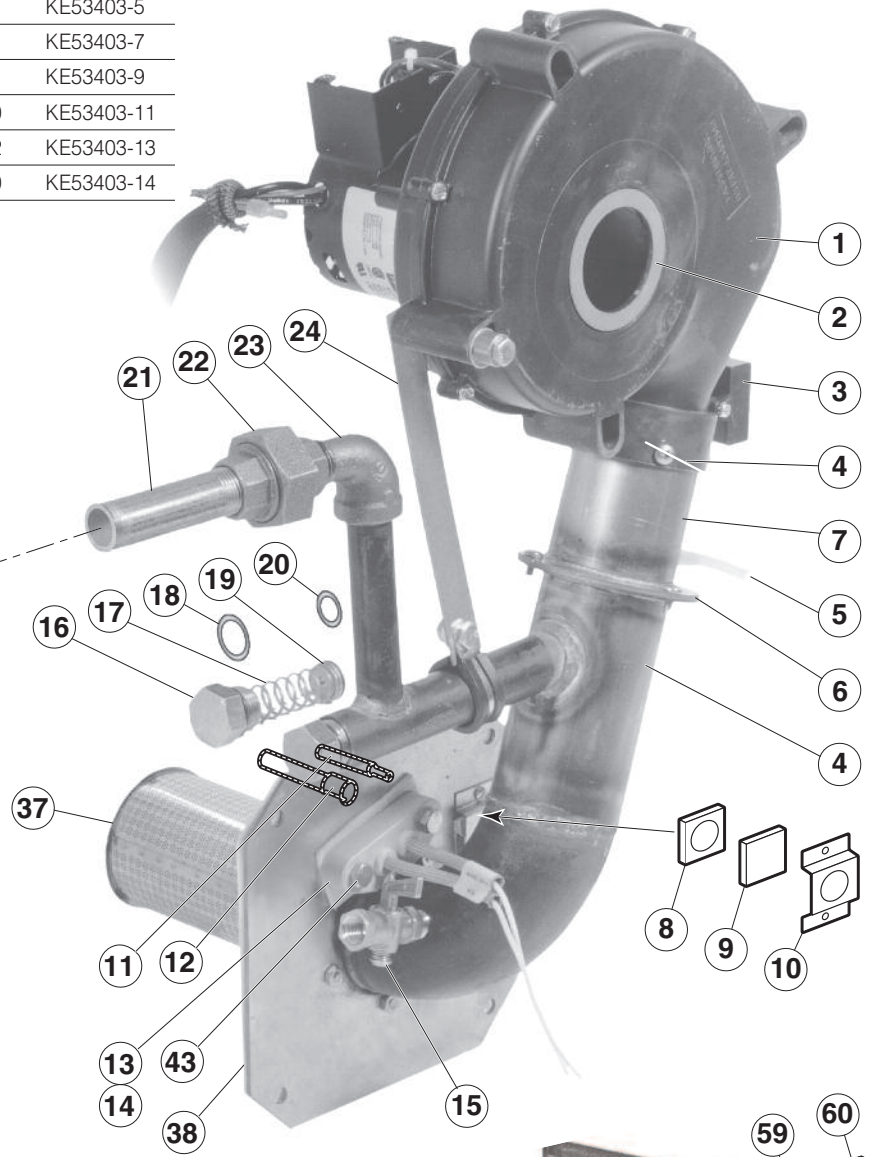
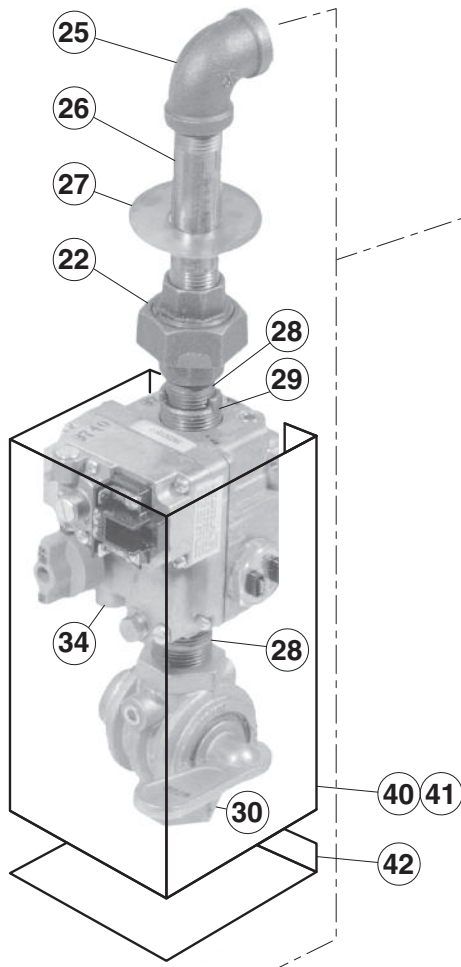

### Tilting Models

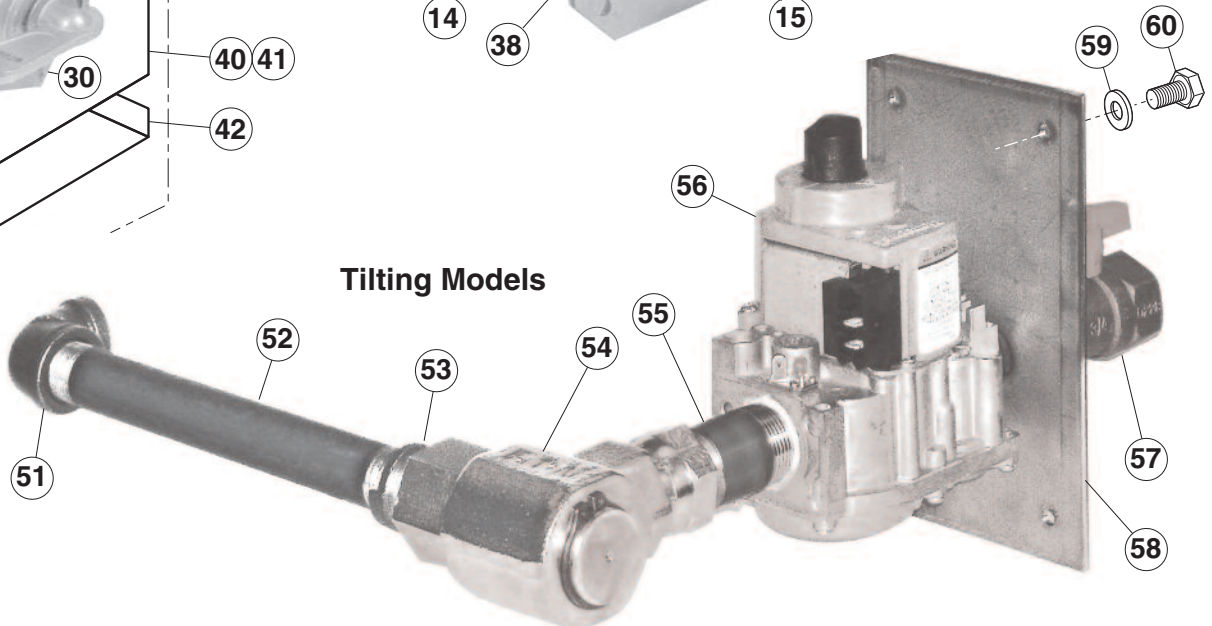

# **GAS CONTROL ASSEMBLY**

<b>ITEM ON.</b>	<b>PART NO.</b>	<b>DESCRIPTION</b>	<b>QTY.</b>
1.	KE53441	BLOWER, 115V, 60 HZ .....	.1
	KE53441-1	BLOWER, 220V, 50 HZ .....	.1
2.	KE54420	AIR INTAKE WASHER (NATURAL GAS, 50hz) .....	.1
	KE54420-1	AIR INTAKE WASHER (PROPANE, 50hz) .....	.1
3.	KE54239	CAPACITOR .....	.1
4.	KE01426-4	MIXING CHAMBER, 40 GALLON KETTLES .....	.1
	KE01426-1	MIXING CHAMBER, 60 GALLON KETTLES .....	.1
	KE01426-2	MIXING CHAMBER, 80 GALLON KETTLES .....	.1
	KE01426-3	MIXING CHAMBER, 100 GALLON KETTLES .....	.1
5.	KE53582	TUBING 1/4 INCH SILICONE .....	.1
	FI05156	HOSE FITTING .....	.1
6.	KE53402-4	AIR ORIFICE, 40 GALLON KETTLES (60hz) .....	.1
	KE53402-1	AIR ORIFICE, 60 - 100 GALLON KETTLES (60hz) .....	.1
	KE53402-2	AIR ORIFICE, 40 GALLON KETTLES (50 HZ BLOWER) .....	.1
	KE53402-3	AIR ORIFICE, 60 - 100 GALLON KETTLES (50 HZ BLOWER) .....	.1
7.	KE01449	BLOWER MOUNTING PIPE ASSEMBLY .....	.1
8.	KE53618	SIGHT GLASS GASKET .....	.1
9.	KE53617	SIGHT GLASS .....	.1
10.	KE53619	SIGHT GLASS RETAINER .....	.1
11.	KE00515	THERMISTOR .....	.1
12.	KE50556-2	WATER LEVEL PROBE .....	.1
13.	KE53437-3	IGNITOR .....	.1
14.	KE53570	GASKET FOR IGNITOR .....	.1
15.	FI05257	SHUT-OFF COCK .....	.1
16.	FI05213	PLUG .....	.1
17.	KE53422	SPRING .....	.1
18.	FA05002-4	"O" RING .....	.1
20.	FA05002-29	"O" RING .....	.1
21.	FI05226-4	NIPPLE, 1/2" NPT, 5 5/16" LONG .....	.1
22.	FI00073	UNION, 1/2" .....	.1
23.	FI00133	ELBOW, 1/2", STREET .....	.1
24.	KE93909	STRIP, TO HOLD BLOWER DOWN .....	.1
25.	FI00040-1	ELBOW, 1/2" .....	.1
26.	N0440C4	NIPPLE, 1/2" NPT, 4" LONG, KGL-60-T .....	.1
	N0440C3-875	NIPPLE, 1/2" NPT, 4" LONG, KGL-80-T .....	.1
27.	KE55004-3	RETAINING PLATE .....	.1
28.	N0640C2	NIPPLE, 1/2" NPT, 2" LONG .....	.1
30.	F01518-1	GAS SHUT-OFF VALVE, 3/4" (NOT FOR FRENCH CE KETTLES) .....	.1
34.	KE55240R	GAS VALVE ASSEMBLY .....	.1
36.	N0640C1-5	NIPPLE, 3/4" NPT, 1 1/2" LONG .....	.1
37.	KE01500-5	BURNER, 40 GALLON KETTLES, 140,000 BTU .....	.1
	KE01500-1	BURNER, 60-100 GALLON KETTLES, 190,000 BTU .....	.1
38.	KE53397	GASKET, BURNER .....	.1
40.	KE601085	COVER FOR GAS VALVE .....	.1
41.	RB018151	GASKET FOR COVER .....	.1
42.	KE601081	BRACKET .....	.1
43.	FA15005	BOLT .....	.2
51.	FI00040-1	ELBOW, 1/2" .....	.1
52.	N0440C8	NIPPLE, 1/2" NPT, 8" LONG .....	.1
53.	FI05231	ADAPTOR .....	.1
54.	FI05222	SWIVEL ELBOW .....	.1
55.	FI05223-6	SPECIAL NIPPLE .....	.1
56.	KE55240R	GAS VALVE ASSEMBLY .....	.1
57.	F01518-1	GAS SHUT-OFF VALVE, 3/4" .....	.1
58.	KE000960	NIPPLE PLATE WELDMENT .....	.1
59.	FA30505-1	WASHER, 1/4" .....	.4
60.	FA11256	HEX BOLT, 1/4-20 X 1/2, 18-8 SS .....	.4

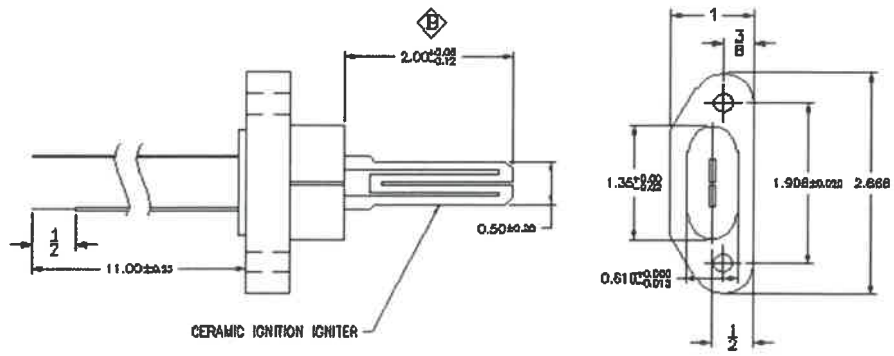

CERAMIC IGNITION IGNITER

KE53437-3 REV A

SUPPLIED AND MANUFACTURED BY NORTON IGNITER PRODUCTS  
 MANUFACTURE # 201Y  
 MANUFACTURER PART # MB478814



**NEW IGNITOR WILL OHM OUT AT ABOUT 161 OHMS.**

# GEARBOX ASSEMBLY

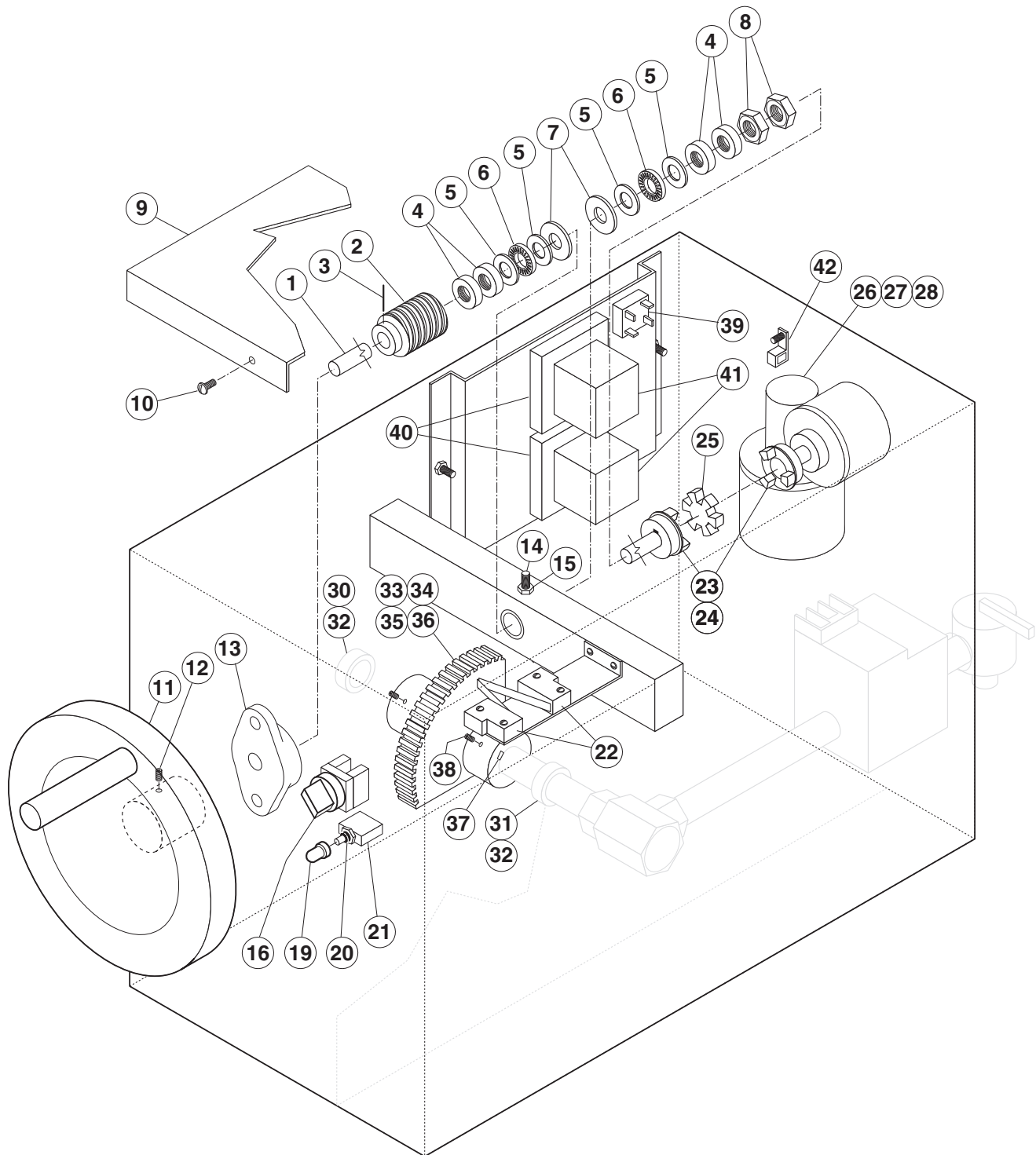

# GEARBOX ASSEMBLY

ITEM NO.	PART NO.	DESCRIPTION	QTY.
1.	KE503752	TILT SHAFT .....	1
2.	KE50315	WORM .....	1
3.	FA95005	TENSION PIN .....	1
4.	KE52193-1	THRUST BEARING SPACER .....	2
5.	KE52192	THRUST WASHER .....	4
6.	KE52191	ROLLER BEARING .....	2
7.	FA30088	WASHER .....	2
8.	FA95008	JAM NUTS .....	2
9.	KE55057-4	LID FOR GEARBOX .....	1
10.	FA95062	PAN HD. PHILLIPS SCREW .....	2
11.	KE00508	HANDWHEEL ASSEMBLY .....	1
12.	FA19501	HANDWHEEL ALLEN SCREW, HEX SOCKET .....	2
13.	KE51730	TILT SHAFT BEARING .....	4
14.	FA19177	HEX SOCKET SET SCREW 5/16-24 X 1" .....	1
15.	FA20047	JAM NUT 5/16-24 .....	1
16.	KE003209-11	Complete Switch .....	1
	KE603208-4	Momentary Switch Activator*** .....	1
	KE603208-7	Contact Section Holder, Latch*** .....	1
	KE603208-9	Contact Block*** .....	4
***NOTE: for units built prior to Dec. 2006 order Complete Switch KE003209-11			
19.	KE50580	WATER RESISTANT BOOT .....	1
20.	FA05002-34	"O" RING, CIRCUIT BREAKER .....	1
21.	KE50579-1	CIRCUIT BREAKER .....	1
22.	KE51007	MICRO SWITCH .....	2
	FA10139	MACHINE SCREW #6-32 X 1" LG .....	4
	KE50498	MICRO SWITCH INSULATION .....	2
	FA32004	TOOTH LOCK WASHER #6 .....	4
23.	KE50582-1	CPLG. ONTARIO BELTING #G-100 5/8 BORE .....	2
24.	FA95055-6	SQUARE KEY 3/16 X 3/16 X 1" LG .....	1
25.	KE50583-1	RUBBER INSERT, ONTARIO BELTING "BUNA N" .....	1
26.	KE52832-1	MOTOR .....	1
27.	FA10487	HEX HD SCREW 1/4-20 X 1" LG .....	4
28.	FA31008	SPLIT LOCKWASHER 1/4" DIA .....	4
29.	FA20026	HEX NUT 1/4 - 20 .....	4
30.	KE517112	LEFT HAND BEARING .....	1
31.	KE517111	RIGHT HAND BEARING .....	1
32.	KE51712	GREASE NIPPLE .....	2
33.	KE001234-2	MICRO SWITCH TRIGGER/WORM GEAR WELDMENT .....	1
34.	FA10772	SOCKET HD. CAP SCREW .....	2
35.	FA20030	JAM NUT .....	2
36.	FA95007-4	RETAINING RING .....	1
37.	FA95055-1	SQUARE KEY .....	1
38.	FA19201	HEX SOCKET SET SCREW 3/8-24 .....	1
39.	KE50581	BRIDGE RECTIFIER .....	1
40.	KE54535	EDGE CONNECTOR (11 PIN) .....	2
41.	KE50753-10	RELAY .....	2
42.	KE50473	GROUND LUG .....	1

# TRUNNION ASSEMBLY

ITEM NO.	PART NO.	DESCRIPTION	QTY.
1.	KE00354	TRUNNION BEARING ASSEMBLY (INCLUDES PART # 3, 4 & 6)	1
2.	KE00351	TRUNNION BEARING ASSEMBLY (INCLUDES PART # 3, 4 & 6)	1
3.	KE51711	ROLLER BEARING	2
4.	KE51571-1	BEARING WASHER	1
5.	FA95081-3	BOLT, 5/16-18 X 1/2"	1
6.	KE51886	GREASE NIPPLE	2
7.	FA11326	BOLT, 5/16-18 X 1 1/2"	4/2
8.	KE50666	SPHERICAL WASHER	1

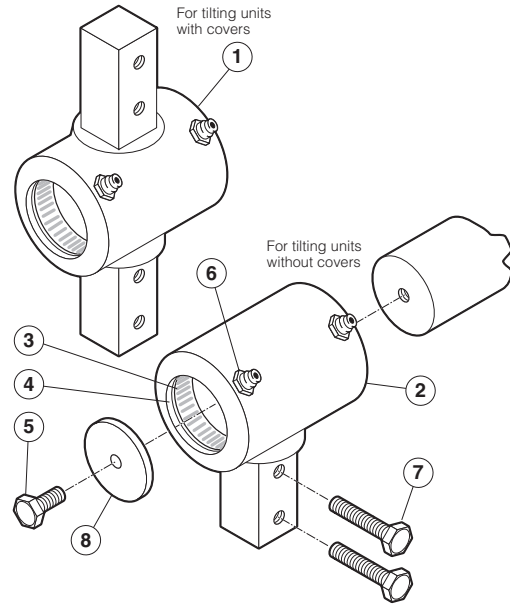

# TANGENT DRAW-OFF VALVE

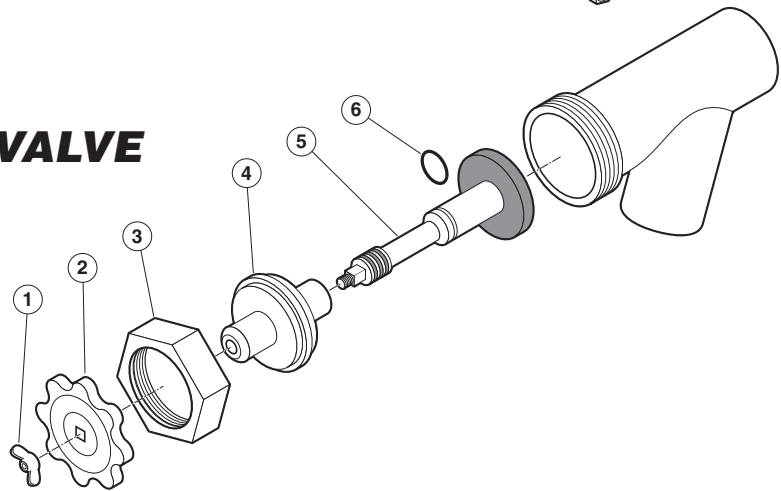

ITEM NO.	PART NO.	DESCRIPTION	QTY.
Complete	KE50972-B	2" DRAW-OFF ASSEMBLY (TD-2)	1
Valve	KE50973	3" DRAW-OFF ASSEMBLY (TD-3)	1
	KE02044-2	2" DRAW-OFF ASSEMBLY (TD-2A with ACME THREAD)	1
	KE02044-4	3" DRAW-OFF ASSEMBLY (TD-3A with ACME THREAD)	1
1.	FA95049	WING NUT, TD-2	1
	FA21501-2	ACCORN NUT, TD-2	1
	FA21501-1	ACCORN NUT, TD-3	1
2.	KE52755	KNOB, TD-2	1
	SE50018	KNOB, TD-3	1
3.	FI05180-1	HEX NUT, TD-2	1
	FI05180-2	HEX NUT, TD-3	1
4.	KE52753	RETAINER, TD-2	1
	SE50013	RETAINER, TD-3	1
5.	KE52752	PISTON, TD-2	1
	SE50010	PISTON, TD-3	1
6.	FA05002-24	"O" RING, TD-2	1
	FA05002-38	"O" RING, TD-3	1

# PRESSURE RELIEF ASSEMBLY

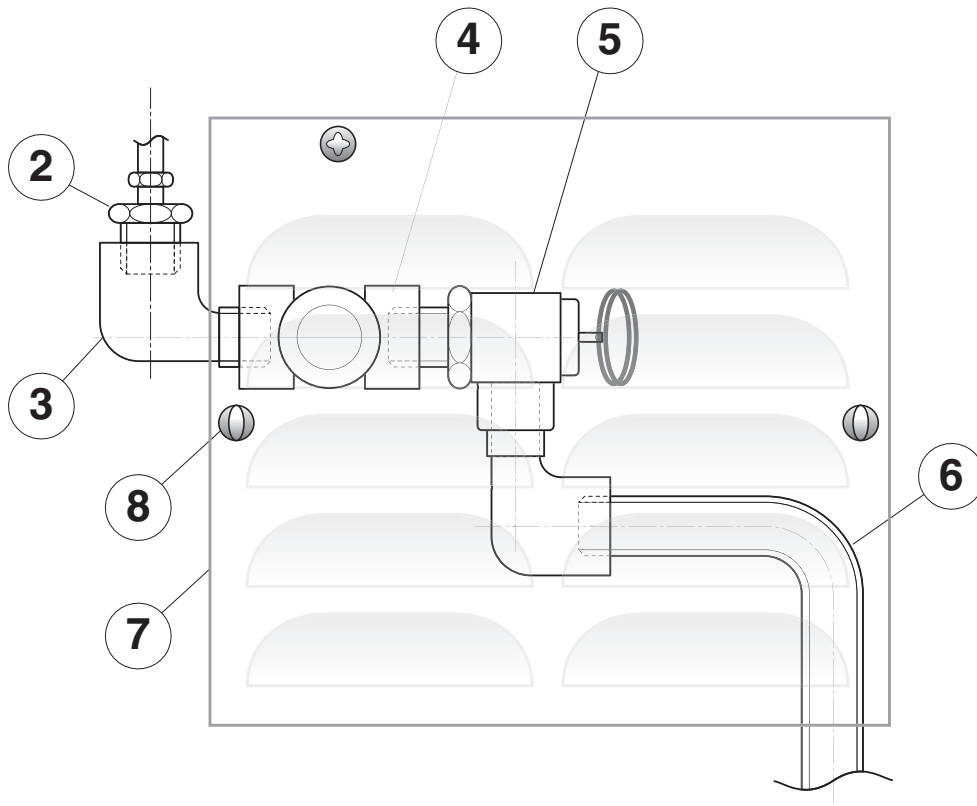
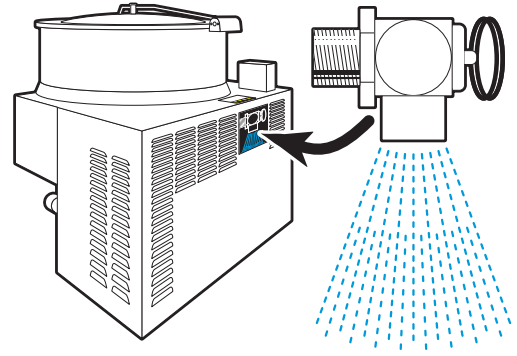

ITEM NO.	PART NO.	DESCRIPTION	QTY.
		<i>PRESSURE RELIEF VALVE ASSEMBLIES</i>	
1.	KE01450	FOR ASME KETTLES (INCLUDES #2-6)	1
	KE01450-1	FOR CE KETTLES (INCLUDES #2-6)	1
2.	FI05049	MALE CONNECTOR, 1/2" PIPE - 1/4" TUBE	1
3.	KE600812-1	STREET ELBOW, 90°, 1/2", BRASS	2
4.	KE600814-1	TEE, 1/2" FPT, BRASS	1
		<i>SAFETY VALVES</i>	
5.	KE54941-5	SAFETY VALVE, 50 PSI, 1/2" (NORTH AMERICA)	1
	KE54941-31	SAFETY VALVE, 50 PSI, 1/2", (EUROPE)	1
6.	KE54223	BLOW DOWN TUBE	1
7.	KE54864	ACCESS PANEL	1
8.	FA11518-4	THUMB SCREW, 10-32 X 1/2" L	2

# HINGE ASSEMBLY

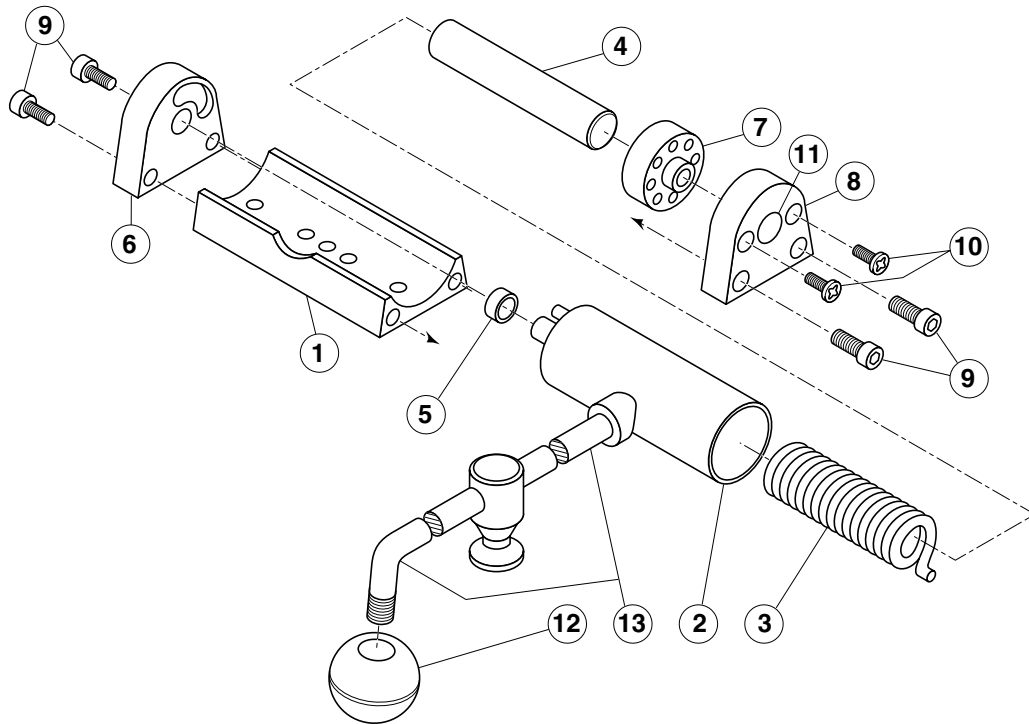

ITEM NO.	PART NO.	DESCRIPTION	QTY.
<b>Hinge Assembly</b>			
1. - 11	KE00597-1	KGL40/T	1
	KE00597-2	KGL60/80/T	1
	KE00597-3	KGL100/T	1
	KE50597-4	KGL40SH/TSH	1
1.	KE50822	Hinge Base	1
2.	KE51217	Hinge Cylinder	1
3.	KE50121-2	<b>Hinge Spring, Light</b> - for KE00597-1	1
	KE50121-1	<b>Hinge Spring, Heavy</b> - for KE00597-2, KE00597-3, KE00597-4	1
4.	KE50823-1	Hinge Pin, Light Spring, LHS	1
5.	KE50824-2	Hinge Bearing, Heavy Spring	1
6.	KE50819-1	Hinge End Piece	1
7.	KE50820	Hinge Insert	1
8.	KE50819	Hinge End Piece, RHS	1
9.	FA11284	Screw, Socket Head	4
10.	FA11507	Cutting Screw,	2
11.	KE54907-10	Plug Button	1
12.	KE50151-2	Knob	1
13.		Cover Handle Assembly (consult factory)	1

The part that you have circled is KE00095. It is made of below parts. I think you are talking about part #3 which is a retaining ring.

#1 – KE50149

#2 – KE50150

#3 – FA95068

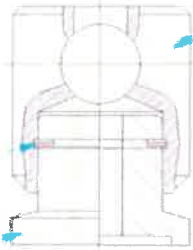

# WRAP COVERS

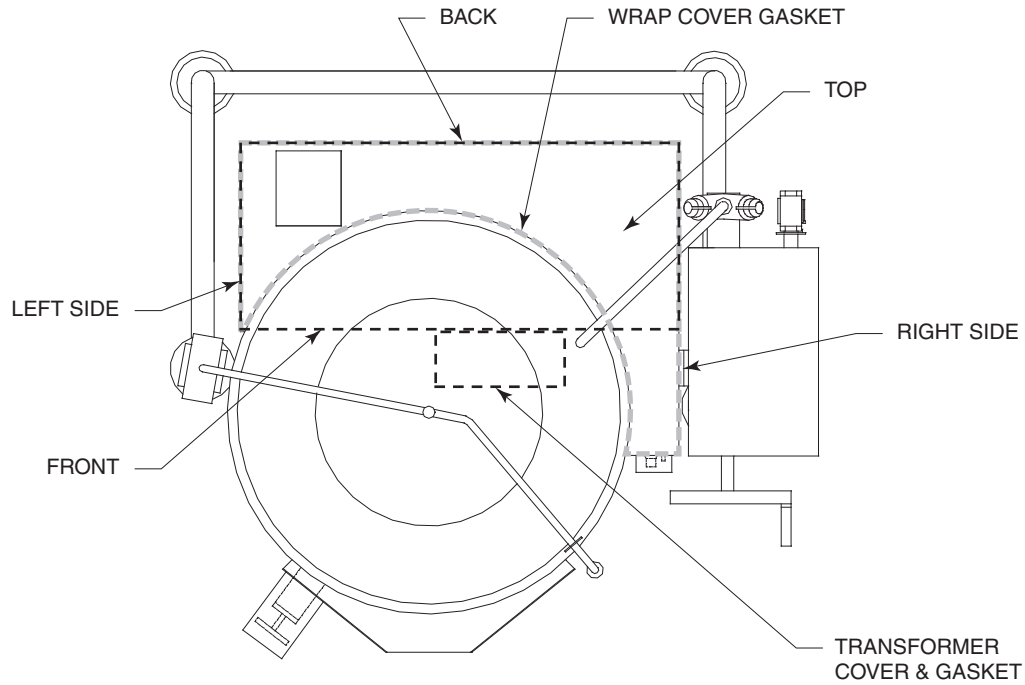

KETTLE	TOP (c/w gasket)	FRONT	LEFT SIDE	RIGHT SIDE	BACK	SERVICE WRAP COVER GASKET	TRANSFORMER COVER	TRANSFORMER COVER GASKET
KGL-40	KE01479	KE53483-4	KE54253	KE01432	KE02186-1	KE54419-1	KE53871	RB01851 (1ft.)
KGL-60	KE01479-1	KE53483-5	KE54253-1	KE01432-1	KE02186-2	KE54419-2	KE53871	RB01851 (1ft.)
KGL-80	KE01479-2	KE53483-6	KE54253-2	KE01432-2	KE02186-3	KE54419-3	KE53871	RB01851 (1ft.)
KGL-100	KE01479-3	KE53483-7	KE54253-3	KE01432-3	KE02186-4	KE54419-4	KE53871	RB01851 (1ft.)
KGL-40-T	KE01479	KE53483	KE54253	KE01432	KE02186-1	KE54419-1	KE53871	RB01851 (1ft.)
KGL-60-T	KE01479-1	KE53483-1	KE54253-1	KE01432-1	KE02186-2	KE54419-2	KE53871-1	RB01851 (1ft.)
KGL-80-T	KE01479-2	KE53483-2	KE54253-2	KE01432-2	KE02186-3	KE54419-3	KE53871-1	RB01851 (1ft.)
KGL-40-SH	KE01479-6	KE53483-5	KE54253-1	KE01432-1	KE02186-2	KE54419-2	KE53871	RB01851 (1ft.)
KGL-60-SH	KE01479-5	KE53483-7	KE54253-3	KE01432-3	KE02186-4	KE54419-4	KE53871	RB01851 (1ft.)
KGL-40-TSH	KE01479-6	KE53483-1	KE54253-1	KE01432-1	KE02186-2	KE54419-2	KE53871-1	RB01851 (1ft.)

# WIRING DIAGRAM - 110-120V, 60 HZ.

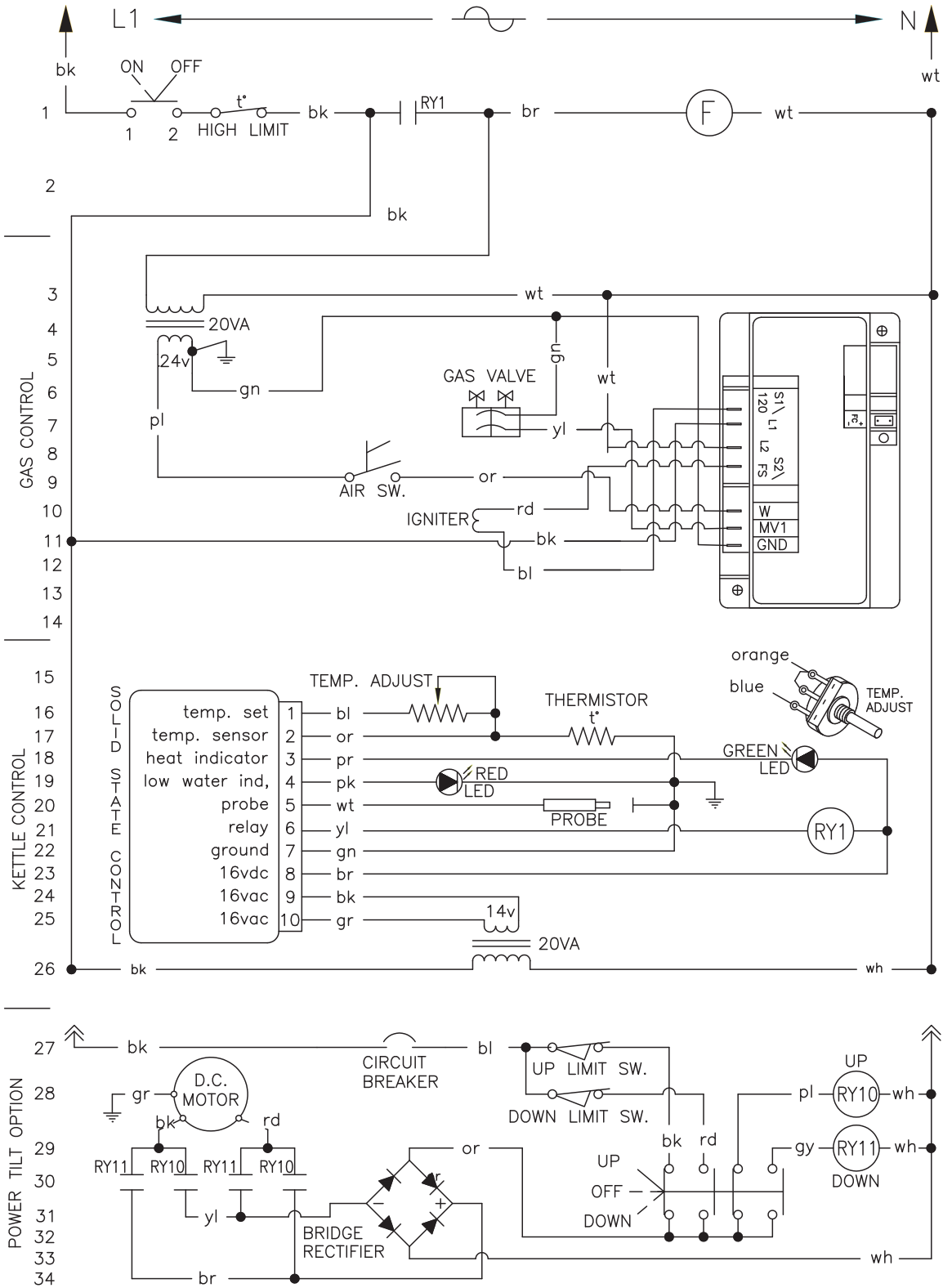

# SPARE PARTS LIST

---

The following is a spare parts listing of parts that wear during normal use or are apt to be misplaced during normal operation. These parts should be kept on hand to prevent loss of time due to a minor problem.

PART NUMBER	DESCRIPTION	QUANTITY
KE00458-1	KETTLE SOLID STATE CONTROL BOX .....	1
KE50753-7	RELAY, 120V .....	1
KE55069-6	SAFETY THERMOSTAT .....	1
SE00114	POTENTIOMETER WITH ON/OFF SWITCH, C/W ITEM #4 .....	1
KE50569-1	KNOB, POTENTIOMETER .....	1
KE00515	THERMISTOR .....	1

The following is a recommended list of spare parts that may be required if the service agency is of some distance away or if down time must be kept to a minimum and spare parts are required for the service agent on site.

PART NUMBER	DESCRIPTION	QUANTITY
KE54941-5	1/2" FPT, 50 PSI., FOR ASME KETTLES .....	1
KE54941-31	1/2" FPT, 50 PSI., FOR CE KETTLE .....	1
KE53838-27	TRANSFORMER, 120-14V. ....	1
KE53469-5	IGNITION CONTROL .....	1
KE00458-1	KETTLE SOLID STATE CONTROL BOX .....	1
KE024004	AIR PRESSURE SWITCH .....	1
KE53838-20	TRANSFORMER 120-24V .....	1
KE52752	PISTON, TD-2 .....	1
SE50010	PISTON, TD-3 .....	1
KE55486-2	L.E.D., RED .....	1
KE55486-3	L.E.D., GREEN .....	1
KE50429-2	PRESSURE GAUGE .....	1
KE53437-3	IGNITOR .....	1