



Visit www.clevelandrange.com to locate a service or sales representative in your area.

Cleveland

Unistand34

34" Equipment Stacking Stand

Installation Manual - Two SteamChef™ 22CET3.1 Steamers on a Unistand34

This manual is updated as new information and models are released. Visit our website for the latest manual.

MODELS:

(2) 22CET3.1
Unistand34

For your future reference.

Model # _____

Serial # _____



Read the manual thoroughly. Improper installation, operation or maintenance can cause property damage, injury, or death.

Part # KE604944-3 Rev A
April 2024

The Installation of Cleveland Range steamers on this stand should only be performed by Cleveland Range authorized technicians. Read entire installation procedure before beginning.

This stand is intended for stacking (2) **SteamChef™ 22CET3.1 Steamers** on a **Unistand34**. An additional mounting kit, P/N KE604946, is needed.

MOUNTING KIT (P/N KE004290) PARTS LIST

Item No.	Part No.	Description	Qty
1	110843	Stacking Spacer, Side Support	2
2	110849	Stacking Spacer, Retainer	1
3	23116	Washer, Flat, 9/32" I.D.	2
4	14665	Nut, 1/4-20, Hex, Locking	2
5*	110987	Strainer, Filter Washer, Garden Hose Inlet (Ght)	2
6	110998	Hose Assembly, Ght(F) X Ght(F), 2 Ft. Long	2
7	14496	Nipple, 1-1/4 Npt X 2-1/2 Schedule 40, Black	2
8	02579	Bushing, Hex, 1-1/2 X 1-1/4 , Black	2
9	085111800	Hose, White, Epdm, Fda Approved 3/4" I.D. X 18.00" Long	1
10	03204	Clamp, Worm Drive, 0.812 - 1.50 Dia.	2
11	06241	Fitting, Hose Barb, 3/4" Hose x 1/2" Mpt, Brass	2
12	110985	Fitting, 1-1/2" Hose X 1-1/2 Npt(M), Plated	2
13	102018	Clamp, Hose, Worm Drive 1.5" - 2.0"	2
14	1109841300	Hose, Epdm, Black, 1-1/2" ID X 2" OD, 13" Long	1
15	20221	Tee, 1-1/2", Black	1
16	20229	Tee, 1-1/2", Brass	1
17	111000	Fitting, Wye Ght(Female) X (2)Ght(Male), Brass	2
18	14324	Nipple, 0.50 Npt X Close; Schedule 40; Brass	1
19*	05253	Elbow, Street, 90° X 1/2"; Brass	2
20	05238	Elbow, 90° Street.; 1 1/2", Black	1
21	112523	Label, Warning	1
26	FA11384	Hex Bolt (18-8 S/S), 3/8-16 X 1 Lg	4
27	FA31031	Split Lockwasher; 3/8, 18-8 S/S	4
28	23136	Washer; Flat; 3/8ID; 7/8OD; 1/16IN THK SST	4

*Note: Items 5 and 19 are supplied with the steamer and not included in this kit.

In addition to knowledge of this procedure, installer must be familiar with the instructions supplied with each SteamChef™ Steamer. These instructions are Cleveland Range P/N KE004035-2.

1. Position stand in selected location so that feet with round mounting pads are at the rear. Use adjustable feet to level stand front-to-back and side-to-side.
2. Set lower steamer directly on stand as shown in Figure 5 (4-inch legs provided with steamer are not used when installing SteamChef™ steamers on a stand). Align steamer so that rear mounting bolts will come up through holes marked “B” in Figure 1 below.

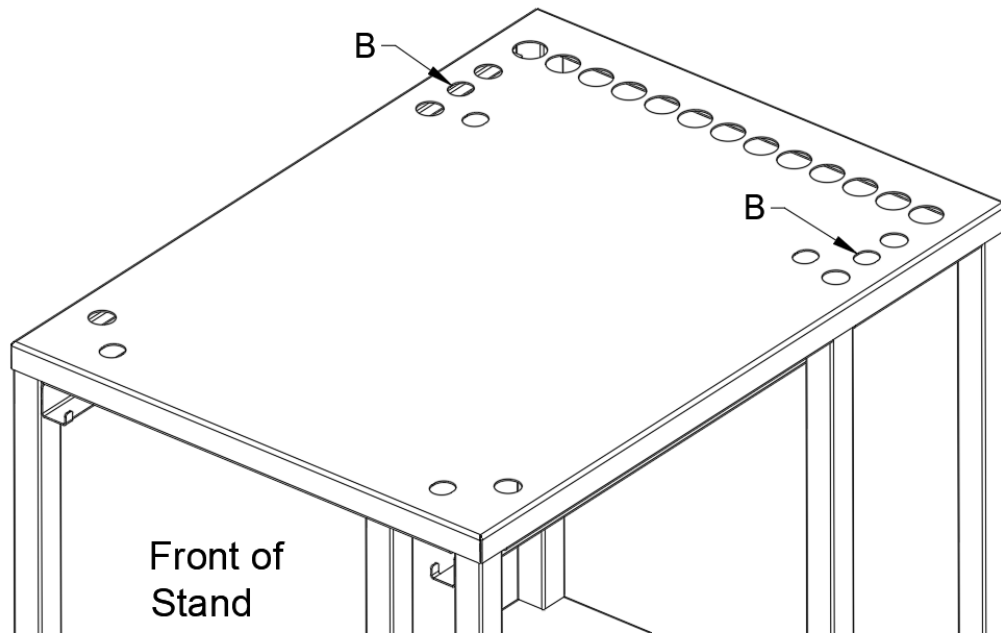

Figure 1

SteamChef™ Mounting Holes

3. Secure lower steamer to stand using 2 sets of bolts and washers provided as shown in Figure 5 (Items 3, 4, and 5).
4. Remove right side panel and seal any gaps between steamer and stand with a suitable RTV Sealant (not provided) as shown in Figure 4.
5. Install stacking spacer side supports and retainer. Set studded side supports (Figure 5, Item 6) on top of lower unit (see Figure 2). End of support with nearer stud must be toward front of steamer. Set retainer (Figure 5, Item 7) over side supports. Side support studs will come up through corresponding holes in retainer and lower edges of retainer will extend over top of steamer (see Figure 3).

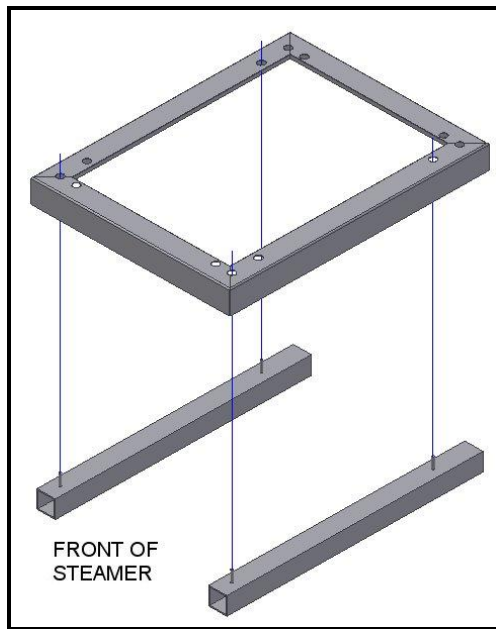

Figure 2

Positioning the Stacking Spacer

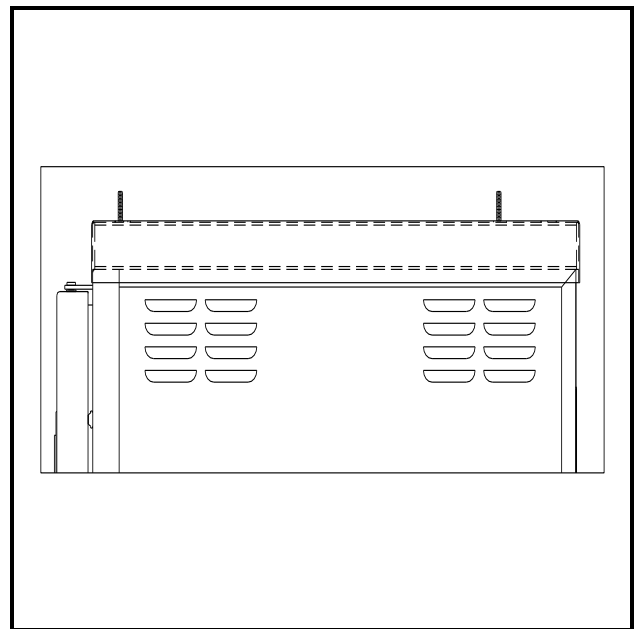

Figure 3

Installed Stacking Spacer

6. Remove side panels from upper steamer. Do not screw 4" legs into steamer. Apply a bead of RTV sealant around entire top perimeter of stacking spacer retainer (see Figure 4 on next page).
7. Place upper steamer on top of retainer so that 1/4-20 studs go through 1/2" nuts that legs would have screwed into.
8. Secure upper unit to stacking spacer using two sets of 1/4" flat washers and locknuts (Items 8 and 9 in Figure 5) installed on the front studs.
9. Attach drain fittings as shown in Figure 5 (Items 10 - 16). Use a suitable pipe thread sealant or Teflon tape (not provided) on all threaded connections.
10. Check length of drain hose (Figure 5, Item 17) and shorten if necessary. Place worm drive clamps (Figure 5, Item 18) over hose and push hose onto upper hose fitting. Slightly rotate lower tee and hose fitting counter-clockwise until lower end of hose can start onto fitting. Slide hose fully onto fitting by rotating tee and fitting back to their original vertical position. Secure hose to fittings with worm drive clamps.
11. Attach inlet water trains for reservoir and condenser as shown in Figure 5 (Items 19 – 23). Use a suitable pipe thread sealant or Teflon tape on all NPT threaded connections. Use a suitable plain washer or strainer washer at all Garden Hose threaded connections (DO NOT USE PIPE THREAD SEALANT OR TEFLON TAPE ON GARDEN HOSE THREADED CONNECTIONS).

Note: Each SteamChef™ steamer is supplied with strainer washers (Figure 5, Item 19) for use on the water inlets. THESE STRAINER WASHERS MUST BE USED ON THE STEAMER WATER INLET CONNECTIONS.

To satisfy sanitation requirements, joints and seams must be sealed with Food Grade RTV Silicone sealant rated at least 250°F and Listed or Classified to ANSI/NSF 51 or 61 Standards.

Sealing Step 3

Before setting upper steamer into place over spacer studs, apply bead of RTV sealant

Sealing Step 2

After stacking spacer is installed, apply a small bead of sealant between edge of

Sealing Step 1

Seal any gaps between bottom of lower steamer and Unistand34 Equipment Stand.

Sealing Step 4

After installation is complete, check all applied sealant and close any gaps with

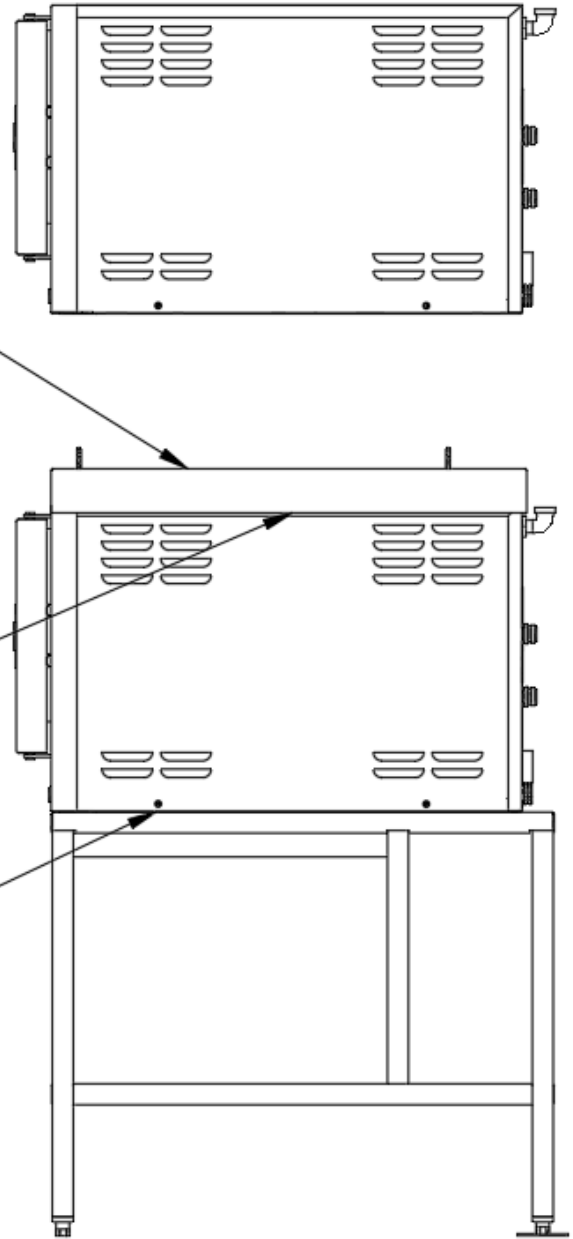

Figure 4

Sealing Requirements

12. After RTV sealant has set, replace side panels removed in Steps 4 and 6. Do not seal right side panels to unit. Right side panels must be easily removable for future service access.
13. Complete installation of steamers as outlined in SteamChef™ Installation Manual, P/N KE004035-2. The stand must be anchored to floor through holes in round mounting pads on rear feet.

NOTES:

1. INSTALL THE PLUMBING AND DRAIN AS SHOWN. ALL THREADED PLUMBING (EXCEPT THOSE OF THE HOSE THREAD TYPE, ITEMS 6 AND 17), REQUIRES THE USE OF PIPE SEALANT OR TEFLON TAPE (NOT PROVIDED).
2. THE END OF THE DRAIN MANIFOLD MUST BE EXTENDED TO A SUITABLE DRAIN. DO NOT PLUMB THE DRAIN SOLID TO THE FLOOR DRAIN, BUT INSTALL IT "FREE AIR VENTED". THERE MUST BE A 1" AIR GAP AT THE DRAIN END. IMPORTANT: WHEN STACKED, A 2" MINIMUM DRAIN CONNECTION IS REQUIRED BETWEEN THE OUTLET OF THE COMMON DRAIN AND THE FLOOR DRAIN. UNDER NO CIRCUMSTANCES SHOULD THE DRAIN PIPING EVER BE SIZED SMALLER THAN COMMON DRAIN OUTLET.

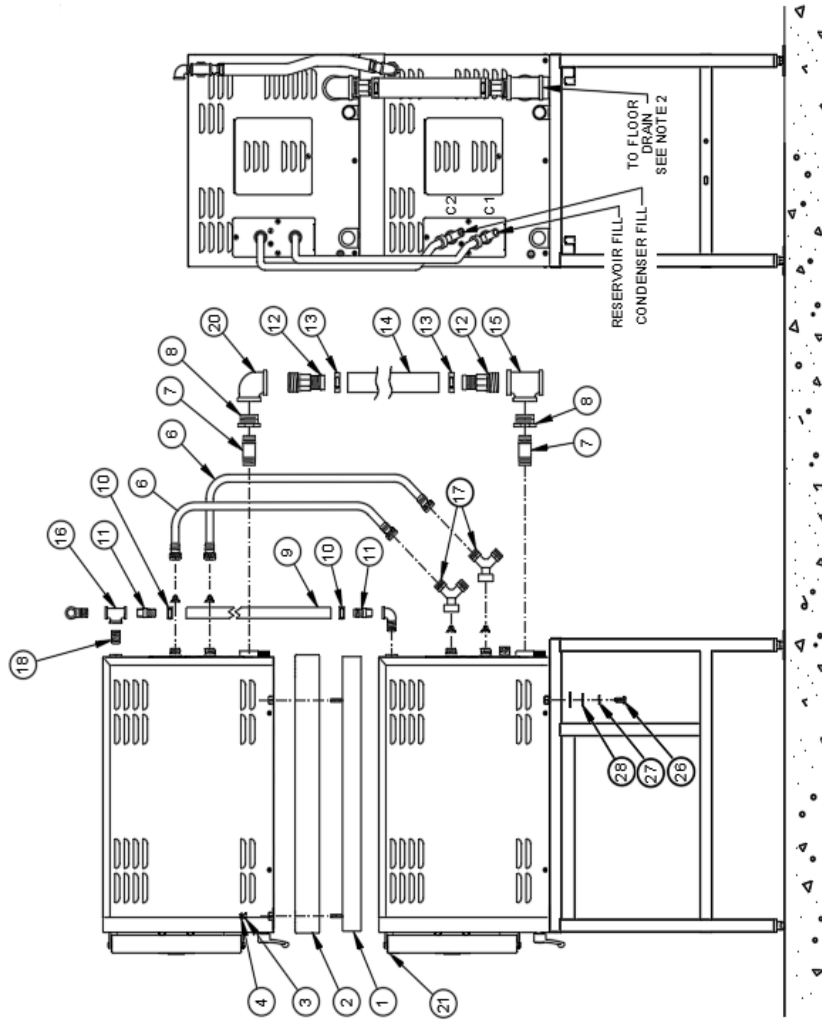

Figure 5
Assembly Diagram for Two SteamChef™ 3 Steamers
Mounting on a Unistand Equipment Stand

28	4	F40206	WASHER, 3/8 18-8 SS
27	4	F431031	SPUT LOCK WASHER, 3/8, 18-8 SS
26	4	F411384	HEX BOLT (18-8 SS), 3/8-16 X 1 LG
21	1	112523	LABEL, WARNING
20	1	06288	ELBOW, 90, 1-1/2" NPT, BLACK
18	1	14324	NIPPLE, CLOSE, 1/2" NPT, BRASS
17	2	111000	FITTING, WYE, GHIF X (2) GHIM, BRASS
16	1	20229	TEE, 1/2" NPT, BRASS
15	1	20221	TEE, 1 1/2" NPT, BLACK IRON
14	1	1108841300	HOSE, BLACK EPDM, 1 1/2" ID X 13' LONG
13	2	102018	CLAMP, HOSE, WORM DRIVE
12	2	110886	FITTING, 1 1/2" HOSE X 1 1/2" NPT (M)
11	2	06241	FTG, HOSE BARB, 3/4" X 1/2" NPT, BRASS
10	2	06304	CLAMP, HOSE, WORM DRIVE, 3/2" I.D. DIA
9	1	08511800	HOSE, WHITE, EPDM, 3/4" ID X 18' LONG
8	2	02579	BUSHING, HEX, 1-1/4" NPT X 1-1/2" NPT, BLK
7	2	14466	NIPPLE, 1-1/4" NPT X 1/2" LONG, BLK, TBE
6	2	110888	HOSE ASSEMBLY, GHF (F) X 2" LONG
4	2	14665	NUT, 1/4-20, HEX, LOCKING
3	2	28116	WASHER, FLAT, 9/32 D
2	1	110849	STACKING SPACER, RETAINER
1	2	110843	STACKING SPACER, SIDE SUPPORT

Cleveland

Cleveland Range, LLC
760 Beta Drive, Unit D
Mayfield Village, Ohio
44143
216.481.4900
800.338.2204

Every new piece of Welbilt Foodservice equipment comes with KitchenCare® and you choose the level of service that meets your operational needs from one restaurant to multiple locations

StarCare – Warranty & lifetime service, certified OEM parts, global parts inventory, performance audited

ExtraCare – CareCode, 24/7 Support, online/mobile product information

LifeCare – Install & equipment orientation, planned maintenance, KitchenConnect™, MenuConnect®

Talk with KitchenCare® • 1-844-724-CARE • www.mtwkitchencare.com



To learn how Welbilt Foodservice and its leading brands can equip you, visit our global web site at www.welbilt.com, then discover the regional or local resources available to you.

©2016 Welbilt Foodservice except where explicitly stated otherwise. All rights reserved. Continuing product improvement may necessitate change of specifications without notice.