



Operators Manual

Installation, Operation & Service

Direct Steam Table Top Kettles

Table-Top Direct Steam Kettles

MODELS: KDT- 1-T
KDT- 3-T
KDT- 6-T
KDT-12-T
KDT-20-T

SD Stands

MODELS: SD- 450
SD- 650
SD- 760
SD-1050
SD-1200
SD-1600
SD-1800

Kettles on SD Stands

MODELS: SD-450- K 6
SD-650- K12
SD-760- K12
SD-760- K20
SD-1050-K 6 6
SD-1200-K 612
SD-1600-K 620
SD-1600-K1212
SD-1600-K1220
SD-1600-K2020

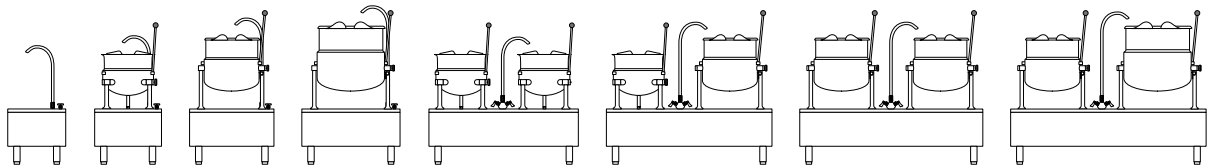
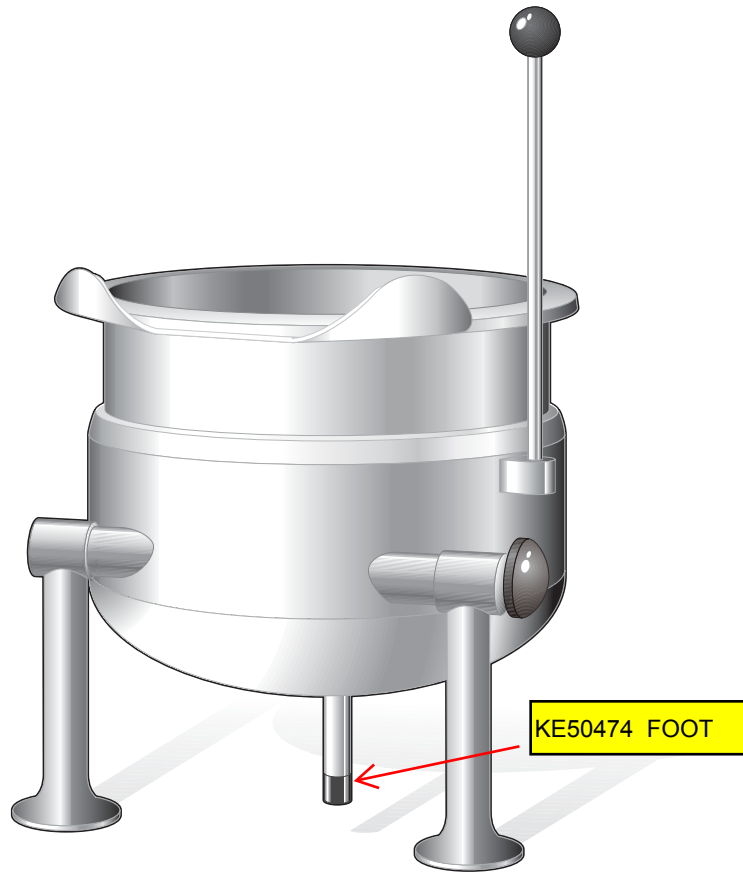

Enodis

1333 East 179th St., Cleveland, Ohio, U.S.A. 44110

Phone: (216) 481-4900 Fax: (216) 481-3782
Visit our web site at www.clevelandrange.com

For your safety

DANGER

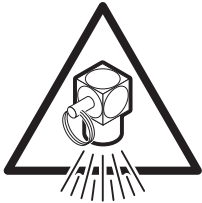

Keep clear of pressure relief discharge.



Keep hands away from moving parts and pinch points.

IMPORTANT



Inspect unit daily for proper operation.

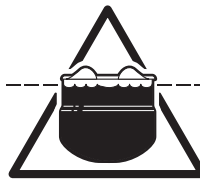

Do not fill kettle above recommended level marked on outside of kettle.

CAUTION



Surfaces may be extremely hot! Use protective equipment.



Wear protective equipment when discharging hot product.



Do not lean on or place objects on kettle lip.

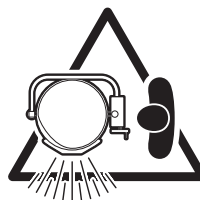

Stand clear of product discharge path when discharging hot product.

SERVICING

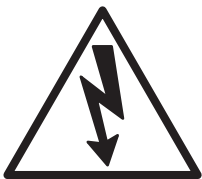

Shut off power at main fuse disconnect prior to servicing.



Ensure kettle is at room temperature and pressure gauge is showing zero or less prior to removing any fittings.

GAS APPLIANCES

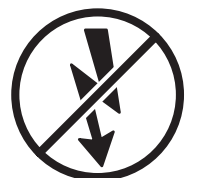

Do not attempt to operate this appliance during a power failure.



Keep appliance and area free and clear of combustibles.

INSTALLATION

GENERAL

Installation of the unit must be accomplished by qualified installation personnel working to all applicable local and national codes. Improper installation of product could cause injury or damage.

This unit is built to comply with applicable standards for manufacturers. Included among those approval agencies are: UL, NSF, ASME/Ntl.Bd., CSA, ETL, CE, and others. Many local codes exist, and it is the responsibility of the owner/installer to comply with these codes.

INSPECTION

Before uncrating, visually inspect the unit for evidence of damage during shipping. If damage is noticed, do not unpack the unit, follow shipping damage instructions.

SHIPPING DAMAGE INSTRUCTIONS

If shipping damage to the unit is discovered or suspected, observe the following guidelines in preparing a shipping damage claim.

1. Write down a description of the damage or the reason for suspecting damage as soon as it is discovered. This will help in filling out the claim forms later. If possible, take a polaroid picture.
2. As soon as damage is discovered or suspected, notify the carrier that delivered the shipment.
3. Arrange for the carrier's representative to examine the damage.
4. Fill out all carrier claims forms and have the examining carrier sign and date each form.

CLEARANCE REQUIREMENTS

The first installation step is to refer to the SPECIFICATION DRAWINGS at the back of this manual in order to determine the exact location of the kettle.

CLEARANCE REQUIREMENTS TO COMBUSTIBLE AND NONCOMBUSTIBLE SURFACES:

	RIGHT	LEFT	BACK
KDT-1-T	4"	0"	0"
KDT-3-T & KDT-6-T	4"	4"	1"
KDT-12-T & KDT-20-T	4"	4"	1.75"

Note: For SD Stands (with or without kettles) zero clearance is required on the sides and back.

KETTLES

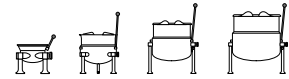
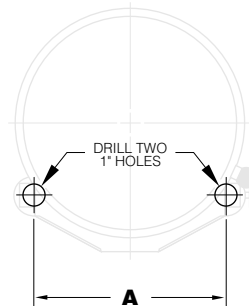

Table-top models must be positioned on a firm stand or existing counter top and secured in place. An optional modular cabinet base (SD Stand), with level-adjustable legs is available.



1. Make two 1" holes for the kettle legs.

	A
KDT-1-T	8 1/8"
KDT-3-T	10"
KDT-6-T	12"
KDT-12-T	19 1/2"
KDT-20-T	23 3/4"

2. Remove the leg mounting locknuts and washers from the kettle's legs.
3. Install the legs into the two 1" holes.
4. Position washers as illustrated and secure the kettle to its' base by refastening the locknut from underneath the cabinet or countertop.
5. Once the kettle is secure, screw the tilt handle into the mounting block welded to the side of the kettle.
6. Install service requirements as required.

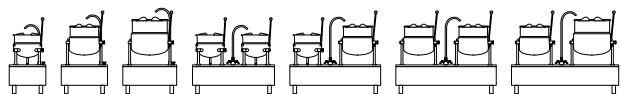
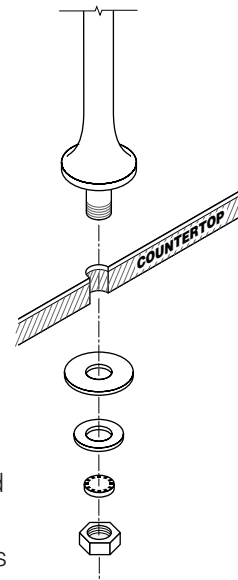

KETTLES c/w SD STAND

1. Place unit in desired location.
2. Place a carpenter's level on the kettle rim and level the stand using the level adjustable feet.
3. Install service requirements as required.

STEAM

All steam plumbing to and from the kettle and steam boiler should be thoroughly cleaned and inspected for dirt and debris before final connection to the kettle are made.

Generally, kettles require 1/2" i.p.s. pipe, 10-45 psi steam pressure. If the steam supply pressure exceeds 45 psi, a pressure reducing valve is required. The steam inlet is at the right side of the kettle, as shown from the front.

A pressure reducing valve is required on the incoming line as shown below. The relief valve should have a capacity of 300 lb/hr (136 kg/hr).

CONDENSATE (Kettles without SD Stands)

Maximum pressure rating on table-top kettles is 50psi. It is highly recommended that a pressure relief valve equal to or less than this pressure be installed on the incoming steam line close to the kettle.

A steam condensate trap must be plumbed to a drain, using minimum 1/2" NPT plumbing. The condensate line is limited to a maximum rise of 10 feet in order for the steam pressure to adequately force the condensate through the plumbing. Any higher rise requires a pump.

If the steam boiler to which this kettle is installed has a condensate return (closed loop system), a 1/2" steam strainer, a 1/2" steam trap, and a 1/2" check valve must be installed on the output (condensate) side of the kettle.

CONDENSATE (Kettles c/w SD Stands)

The stand comes factory plumbed so the condensate is connected to the stands drain manifold.

POTABLE WATER

The water faucet (optional on kettles purchased without SD stands) with swing spout, requires 1/2 inch O.D. copper tube plumbing for hot or cold water supplies to the faucet (SPK - cold water connection only, DPK - hot and cold water connection).

FINAL INSTALLATION CHECK

1. Partially fill the kettle with water.
2. Slowly turn the steam supply valve's knob to the open position.
3. Release the safety valve, ensuring that the steam escapes freely. Stay clear of steam exhaust when releasing the safety valve.
4. Observe that the water in the kettle comes to a boil.
5. Close the steam supply valve.
6. Drain off the water by tilting the kettle.

RECOMMENDED PIPING SCHEMATICS

(all service connections shown supplied by others)

KETTLES c/w SD STANDS

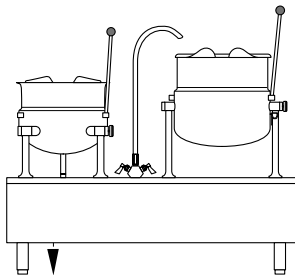

TO DRAIN (CONDENSATE RETURN PLUMBED TO 1 1/2" DRAIN MANIFOLD)

KETTLES

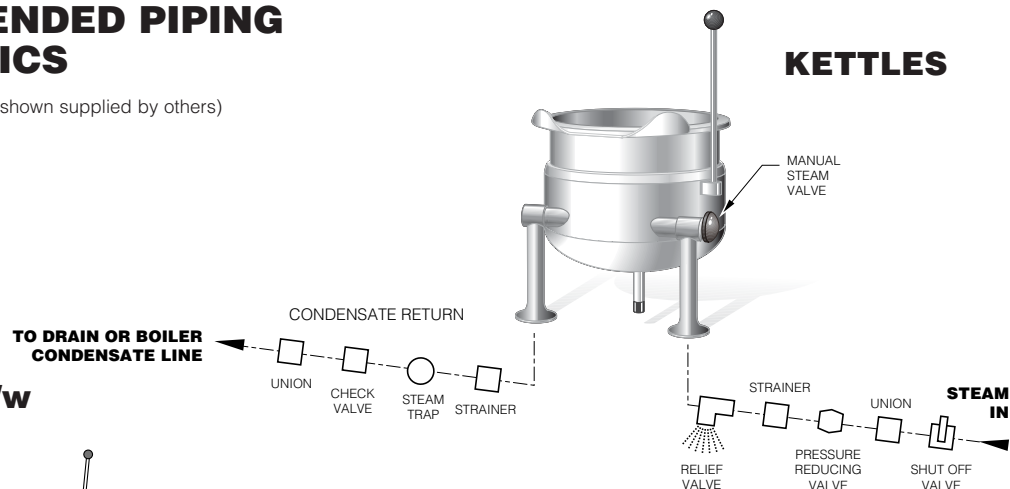

OPERATING INSTRUCTIONS

CLEVELAND STEAM COOKING EQUIPMENT IS INTENDED FOR COMMERCIAL USE ONLY BY PROFESSIONALLY TRAINED PERSONNEL.

OPERATION

1. Ensure that there is an adequate steam supply to the kettle.

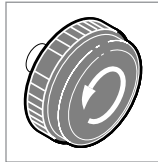

2. Turn the steam control valve to the open position by turning the knob counter-clockwise, then allow the kettle to preheat.

NOTE: When cooking egg and milk products, the kettle should NOT be preheated, as products of this nature adhere to hot cooking surfaces. These types of foods should be placed in the kettle before heating is begun.

3. Fill kettle with product to desired level.

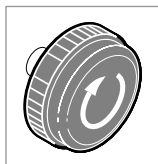

4. When the product has reached the desired temperature, regulate the heat, as required, by turning the steam control valve clockwise for less steam, and therefore, a lower temperature.

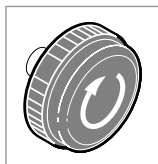

5. When cooking is complete, close the steam control valve by turning the knob clockwise.

FOR KETTLE/STEAMER COMBINATIONS:

If the boiler in a steamer is supplying steam to a kettle, always heat the kettle first. After the kettle contents are heated, and the boiler's steam pressure returns to normal, the steamer may be used. Pressure steamer compartments should be sequentially started, and preheated before cooking.

NOTE: As with cleaning food soil from any cookware, an important part of kettle cleaning is to prevent food from drying on. For this reason, cleaning should be completed immediately after cooked foods are removed. Please read the "Care and Cleaning" instructions for detailed kettle washing procedures.

Marine Lock (12 & 20 gal. models only)

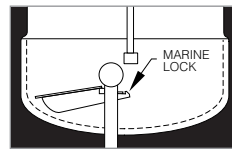

If your unit is equipped with a marine lock to prevent accidental tilting, it must be inspected daily to insure it moves freely and

automatically locks into place when kettle is returned to upright position.

Use the following procedure to tilt the kettle.

1. Securely grasp the tilt handle.
2. Push the marine lock button down to unlock tilting mechanism.
3. Pull the handle to tilt the kettle.
4. When you return the kettle to its' original upright position the marine lock will latch automatically.



CLEANING INSTRUCTIONS



CARE AND CLEANING

Cooking equipment must be cleaned regularly to maintain its fast, efficient cooking performance and to ensure its continued safe, reliable operation. The best time to clean is shortly after each use (allow unit to cool to a safe temperature).

WARNINGS

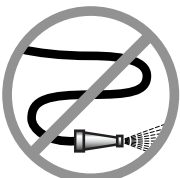
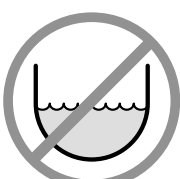
- ⇒  Do not use detergents or cleansers that are chloride based or contain quaternary salt.
Chloride Cleaners
- ⇒  Do not use a metal bristle brush or scraper.
Wire Brush &
- ⇒  Steel wool should never be used for cleaning the stainless steel.
Steel Pads
- ⇒  Unit should never be cleaned with a high pressure spray hose.
High Pressure Spray Hose
- ⇒  Do not leave water sitting in unit when not in use.
Stagnant Water

CLEANING INSTRUCTIONS

1. Turn unit off.
2. Remove drain screen (if applicable). Thoroughly wash and rinse the screen either in a sink or a dishwasher.
3. Prepare a warm water and mild detergent solution in the unit.
4. Remove food soil using a nylon brush.
5. Loosen food which is stuck by allowing it to soak at a low temperature setting.
6. Drain unit.
7. Rinse interior thoroughly.
8. If the unit is equipped with a **Tangent Draw-Off Valve**, clean as follows:
 - a) Disassemble the draw-off valve first by turning the valve knob counter-clockwise, then turning the large hex nut counter-clockwise until the valve stem is free of the valve body.
 - b) In a sink, wash and rinse the inside of the valve body using a nylon brush.
 - c) Use a nylon brush to clean tangent draw-off tube.
 - d) Rinse with fresh water.
 - e) Reassemble the draw-off valve by reversing the procedure for disassembly. The valve's hex nut should be hand tight only.
9. If the unit is equipped with a **Butterfly Valve**, clean as follows:
 - a) Place valve in open position.
 - b) Wash using a warm water and mild detergent solution.
 - c) Remove food deposits using a nylon brush.
 - d) Rinse with fresh water.
 - e) Leave valve open when unit is not in use.
10. Using mild soapy water and a damp sponge, wash the exterior, rinse, and dry.

NOTES

- ⇒ For more difficult cleaning applications one of the following can be used: alcohol, baking soda, vinegar, or a solution of ammonia in water.
- ⇒ Leave the cover off when the kettle is not in use.
- ⇒ For more detailed instructions refer to the Nafem Stainless Steel Equipment Care and Cleaning manual (supplied with unit).

STAINLESS STEEL EQUIPMENT CARE AND CLEANING

(Supplied courtesy of Nafem. For more information visit their web site at www.nafem.org)

Contrary to popular belief, stainless steels ARE susceptible to rusting.

Corrosion on metals is everywhere. It is recognized quickly on iron and steel as unsightly yellow/orange rust. Such metals are called "active" because they actively corrode in a natural environment when their atoms combine with oxygen to form rust.

Stainless steels are passive metals because they contain other metals, like chromium, nickel and manganese that stabilize the atoms. 400 series stainless steels are called ferritic, contain chromium, and are magnetic; 300 series stainless steels are called austenitic, contain chromium and nickel; and 200 series stainless, also austenitic, contains manganese, nitrogen and carbon. Austenitic types of stainless are not magnetic, and generally provide greater resistance to corrosion than ferritic types.

With 12-30 percent chromium, an invisible passive film covers the steel's surface acting as a shield against corrosion. As long as the film is intact and not broken or contaminated, the metal is passive and stain-less. If the passive film of stainless steel has been broken, equipment starts to corrode. At its end, it rusts.

Enemies of Stainless Steel

There are three basic things which can break down stainless steel's passivity layer and allow corrosion to occur.

1. Mechanical abrasion
2. Deposits and water
3. Chlorides

Mechanical abrasion means those things that will scratch a steel surface. Steel pads, wire brushes and scrapers are prime examples.

Water comes out of the faucet in varying degrees of hardness. Depending on what part of the country you live in, you may have hard or soft water. Hard water may leave spots, and when heated leave deposits behind that if left to sit, will break down the passive layer and rust stainless steel. Other deposits from food preparation and service must be properly removed.

Chlorides are found nearly everywhere. They are in water, food and table salt. One of the worst chloride perpetrators can come from household and industrial cleaners.

So what does all this mean? Don't Despair!

Here are a few steps that can help prevent stainless steel rust.

1. Use the proper tools.

When cleaning stainless steel products, use non-abrasive tools. Soft cloths and plastic scouring pads will not harm steel's passive layer. Stainless steel pads also can be used but the scrubbing motion must be in the direction of the manufacturers' polishing marks.

2. Clean with the polish lines.

Some stainless steel comes with visible polishing lines or "grain." When visible lines are present, always scrub in a motion parallel to the lines. When the grain cannot be seen, play it safe and use a soft cloth or plastic scouring pad.

3. Use alkaline, alkaline chlorinated or non-chloride containing cleaners.

While many traditional cleaners are loaded with chlorides, the industry is providing an ever-increasing choice of non-chloride cleaners. If you are not sure of chloride content in the cleaner used, contact your cleaner supplier. If your present cleaner contains chlorides, ask your supplier if they have an alternative. Avoid cleaners containing quaternary salts; it also can attack stainless steel and cause pitting and rusting.

4. Treat your water.

Though this is not always practical, softening hard water can do much to reduce deposits. There are certain filters that can be installed to remove distasteful and corrosive elements. To insure proper water treatment, call a treatment specialist.

5. Keep your food equipment clean.

Use alkaline, alkaline chlorinated or non-chloride cleaners at recommended strength. Clean frequently to avoid build-up of hard, stubborn stains. If you boil water in stainless steel equipment, remember the single most likely cause of damage is chlorides in the water. Heating cleaners that contain chlorides have a similar effect.

6. Rinse, rinse, rinse.

If chlorinated cleaners are used, rinse and wipe equipment and supplies dry immediately. The sooner you wipe off standing water, especially when it contains cleaning agents, the better. After wiping equipment down, allow it to air dry; oxygen helps maintain the stainless steel's passivity film.

7. Never use hydrochloric acid (muriatic acid) on stainless steel.

8. Regularly restore/passivate stainless steel.

Recommended cleaners for specific situations

Job	Cleaning Agent	Comments
Routine cleaning	Soap, ammonia, detergent, Medallion	Apply with cloth or sponge
Fingerprints & smears	Arcal 20, Lac-O-Nu Ecoshine	Provides barrier film
Stubborn stains & discoloration	Cameo, Talc, Zud, First Impression	Rub in direction of polish lines
Grease & fatty acids, blood, burnt-on-foods	Easy-off, De-Grease It Oven Aid	Excellent removal on all finishes
Grease & oil	Any good commercial detergent	Apply with sponge or cloth
Restoration/Passivation	Benefit, Super Sheen	

Review

1. Stainless steels rust when passivity (film-shield) breaks down as a result of scrapes, scratches, deposits and chlorides.
2. Stainless steel rust starts with pits and cracks.
3. Use the proper tools. Do not use steel pads, wire brushes or scrapers to clean stainless steel.
4. Use non-chlorinated cleaners at recommended concentrations. Use only chloride-free cleaners.
5. Soften your water. Use filters and softeners whenever possible.
6. Wipe off cleaning agent(s) and standing water as soon as possible. Prolonged contact causes eventual problems.

To learn more about chloride-stress corrosion and how to prevent it, contact the equipment manufacturer or cleaning materials supplier.

Developed by Packer Engineering, Naperville, Ill., an independent testing laboratory.

SERVICE PARTS

STEAM CONTROL ASSEMBLY

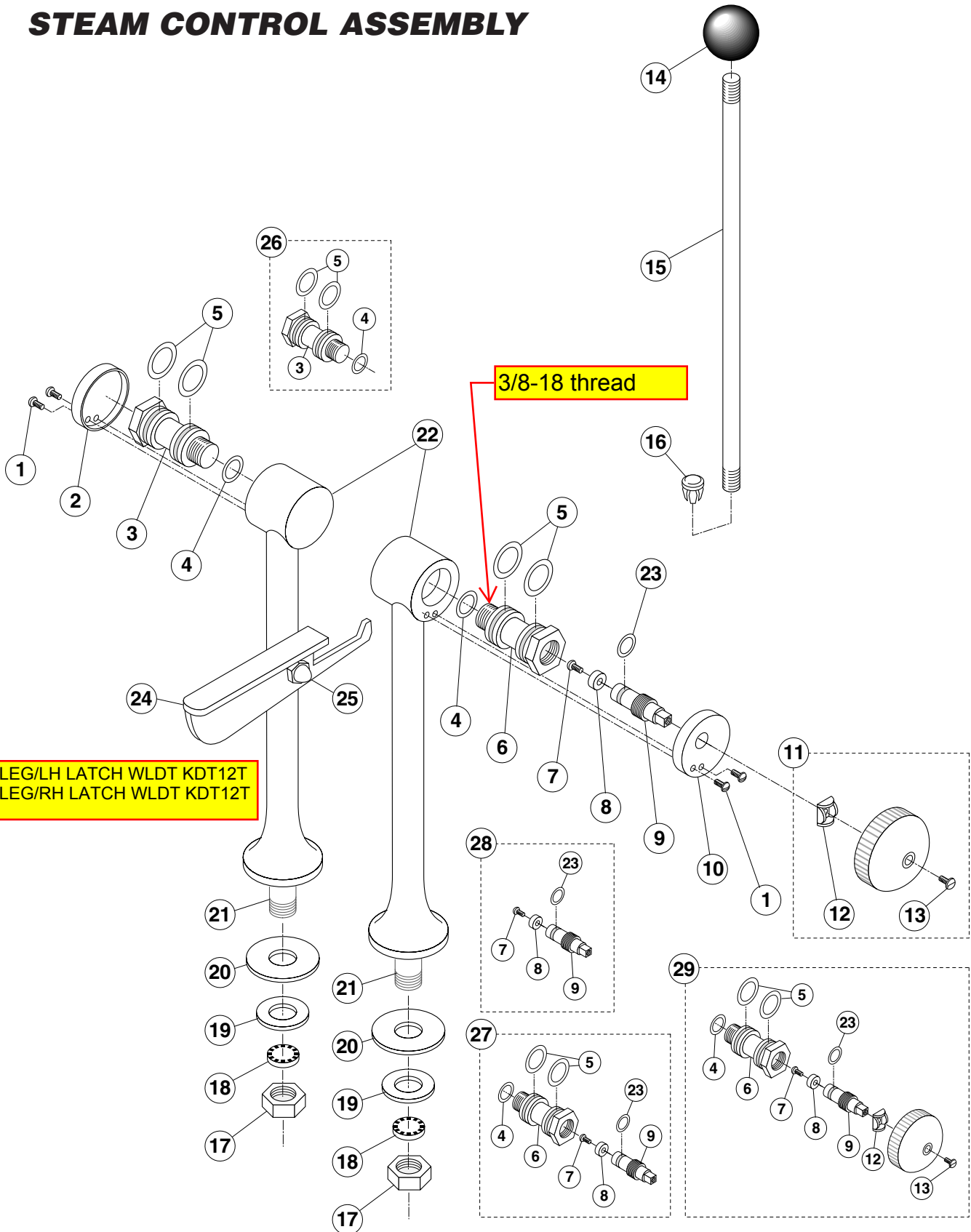

STEAM CONTROL ASSEMBLY

ITEM NO.	PART NO.	DESCRIPTION	QTY.
1.	FA11056	Binding Head Screw, 6-32 x 1/2" Ig.	4
2.	KE50458	End Cap, condensate return	1
3.	KE50455-1	Trunnion, condensate return	1
4.	FA05002-35	"O" Ring	2
5.	FA05002-37	"O" Ring	4
6.	KE50460-1	Trunnion, steam inlet	1
7.	FA11089	Binding Head Screw, 8-32 x 1/4" Ig.	1
8.	KE51713	Washer, steam valve	1
9.	KE50459	Operating Stem	1
10.	KE50457	End Cap, steam inlet	1
11.	SE00028	Steam Control Knob Assembly (c/w Item No. 12, 13 & Knob)	1
12.	KE51888	Retaining Washer	1
13.	FA11092	Binding Head Screw, 8-32 x 1/2" Ig.	1
14.	KE50151-2	Knob, threaded (after 07/94)	1
	KE50151	Knob, non threaded (prior to 06/94)	1
15.	KE50886-1	Handle, KDT-1-T	1
	KE50886-2	Handle, KDT-3-T	1
	KE50886-3	Handle, KDT-6-T & KDT-12-T	1
	KE50886-4	Handle, KDT-20-T	1
16.	KE50475	Plug Button	1
17.	KE52697	Lock Nut, 1/2" NPS	2
18.	FA32500	Lockwasher	2
19.	FA30502	Washer, satin coat	2
20.	KE50467	Washer, Foot	2
21.	KE50465	Service Pipe, KDT-1-T & KDT-3-T	2
	KE52030	Service Pipe, KDT-6-T	2
	KE50463	Service Pipe, KDT-12-T	2
	KE50464	Service Pipe, KDT-20-T	2
22.	T40272	Leg Assembly, KDT-1-T (c/w Item No. 17-21)	2
	T40218	Leg Assembly, KDT-3-T (c/w Item No. 17-21)	2
	KE00896	Leg Assembly, KDT-6-T (c/w Item No. 17-21)	2
	KE00203	Leg Assembly, KDT-12-T (c/w Item No. 17-21)	2
	KE00204	Leg Assembly, KDT-20-T (c/w Item No. 17-21)	2
23.	FA05002-12	"O" Ring	1
24.	KE01115-1	Right Hand Marine Lock Latch, KDT-12-T & KDT20-T only	1
24.	KE01115	Left Hand Marine Lock Latch, KDT-12-T & KDT20-T only	1
25.	KE52632	Crown Nut, KDT-12-T & KDT20-T only	1
26.	SE00096	Steam Outlet Assembly	1
27.	SE00011	Trunnion Assembly, steam inlet	1
28.	SE00029	Operating Stem Assembly, steam inlet	1
29.	SE00030	Steam Inlet Control Assembly	1



Requires Knob -
Item No.
KE50151-2

SE00112 Trunnion rebuild kit

00908 O Ring Lubrication

KDT-10T

PARTS COMMON TO KE02305-1 & KE02305-2			
ITEM	PART_#	DESCRIPTION	QTY
2	KE50474	FOOT	1
3	KE00896	LEG ASSEMBLY	2
4	KE50455-2	TRUNNION; MODIFIED ←	2
5	FA05002-37	O-RING; VITON, 13/16 X 1 X 3/32	4
6	FA05002-35	O-RING; VITON, 3/4 X 7/8 X 1/16	2
7	KE50458	END CAP	2
8	FA11056	S.S. SCREW, PAN HEAD, #6-32 X 1/2	4
9	KE54670-6	HANDLE	1
10	KE50151-2	KNOB, FOR HANDLE	1
11	KE95010	LABEL; NSF	1
12	KE95089-4	NAMEPLATE; "CLEVELAND"	1
13	KE50885	LABEL "HOT/CHAUD"	1
14	FA21501	ACORN NUT, 1/2-13, S.S.	1
15	KE54835-5	LEG BRACE	1

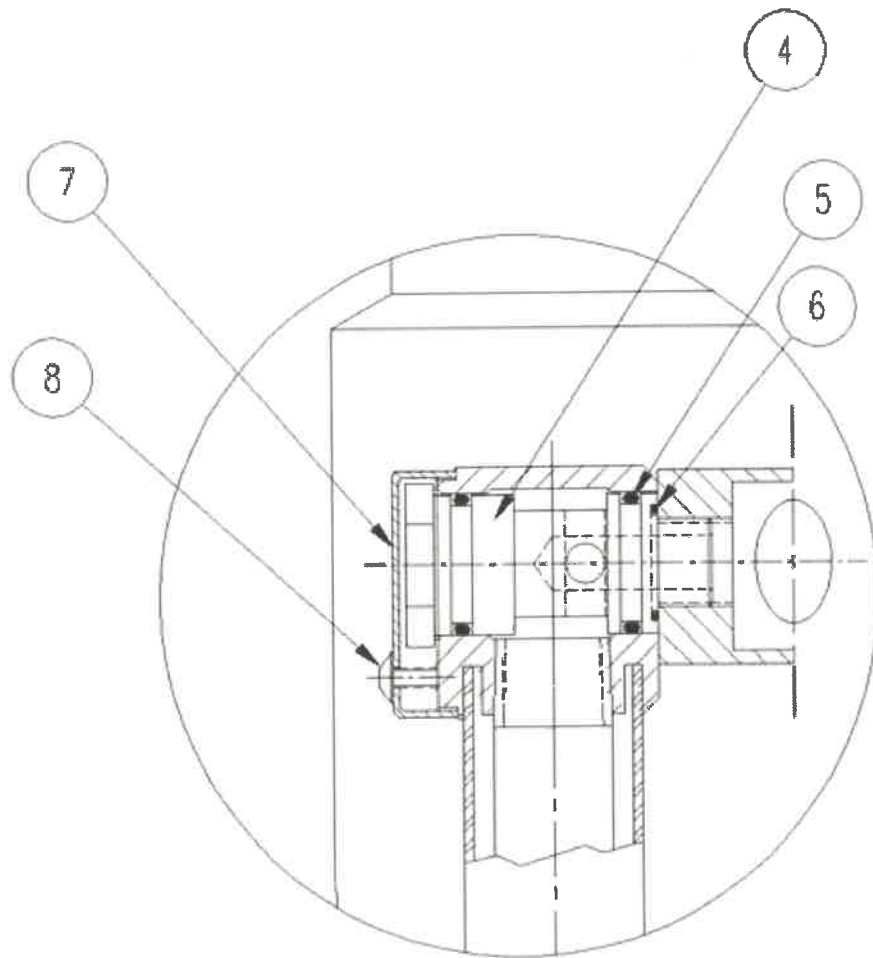

PLUMBING ASSEMBLY (for SD Stands)

ITEM NO.	PART NO.	DESCRIPTION	QTY.
1.	FI00169	Tee, 1/2" NPT. (single kettle units)	1
		(twin kettle units)	3
2.	KE54941-5	Safety Valve, 50 PSI, 1/2" (North America) (single kettle units)	1
		(twin kettle units)	2
	KE54941-31	Safety Valve, 50 PSI, 1/2", (Europe) (single kettle units)	1
		(twin kettle units)	2
3.	FA95010	Jam Nut, #3/4-10	4
4.	KE51340	Leg	4
5.	SD50000	Strainer Assembly	1
6.	SD50042	Radiator Hose, 4" lg.	1
7.	FI05131	Hose Clamp	2
8.	SD50043	Nipple, threaded one end only	1
9.	KE51367	Check Valve, 1 1/4" NPT	1
10.	FI00670	Nipple	1
11.	FI00136	90° Street Elbow, 1 1/4" NPT	1
12.	FI00191	Cap, 1 1/2" NPT	1
13.	KE00648	Drain Pipe Assembly	1
14.	FI00044	90° Elbow, 1 1/2" NPT	1
15.	FI05027	Pipe Strap	2
16.	FI05047	Reducer	1
17.	FI05077	Compression Elbow (single kettle units)	1
	SD50027	Steam Trap	1
19.	FI05049	Male Connector	1
20.	KE51249	Strainer, 1/2" NPT	1
21.	FI00596	Nipple, 1/2" NPT	1
22.	FI00266	Coupling, 1/2" NPT	1
23.	FI05048	Compression Tee (twin kettle units)	1
24.	FI00586	Nipple	1
25.	FI05029	Hose Fitting, 1/2"	2
26.	KE51391	Hose Clamp	2
27.	SD50034	Hose, 20" (SD1050K66)	1
	SD50035	Hose, 17" (SD1200K612)	1
	SD50036	Hose, 27" (SD1600K620, 1212, 12,20 & 2020)	1
28.	FI05028	90° Swivel Elbow	1
29.	SDP	Sliding Drain Pan Assembly	1
30.		Front Access Panels	
	SD50067	(SD450 series)	1
	SD50068	(SD650 series)	1
	SD50106	(SD760 series)	1
	SD50069	(SD1050 series)	1
	SD50070	(SD1200 series)	1
	SD50071	(SD1600 series)	1

PART LIST			
ITEM	QTY	NAME	DESCRIPTION
1	1	SD50015	DRAIN PAN, MODIFIED
2	1	KE602430	BRACKET FOR SD PAN
3	1	SD50110-2	SPLASH SHIELD
4	1	SK50003	BEEHIVE STRAINER

#	DESCRIPTION	DATE	APPROVED
B	SECTION A-A ADDED, BEEHIVE STRAINER WAS SPOT WELDED FROM PAN TOP	09/23/2009	HJamshidi

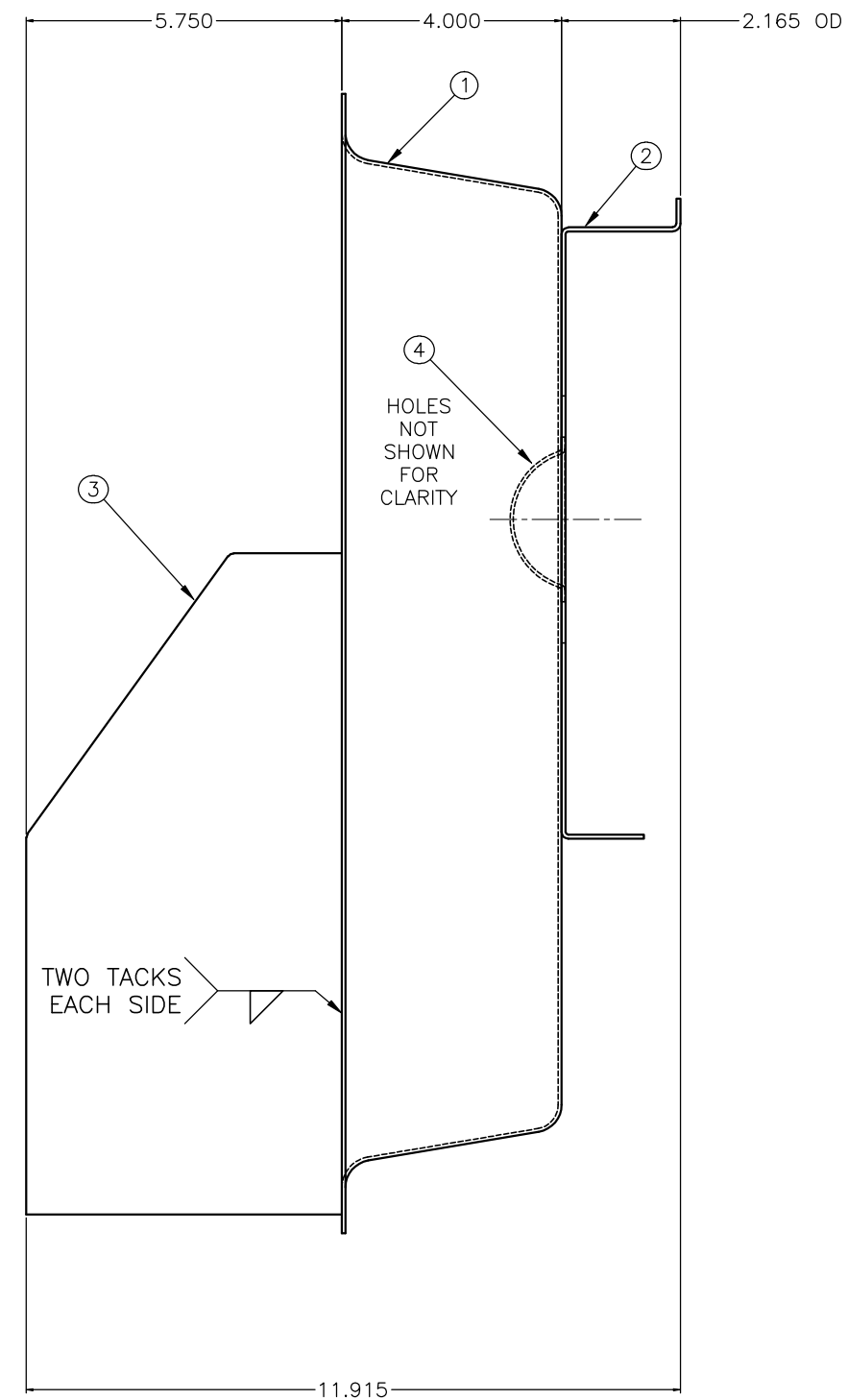
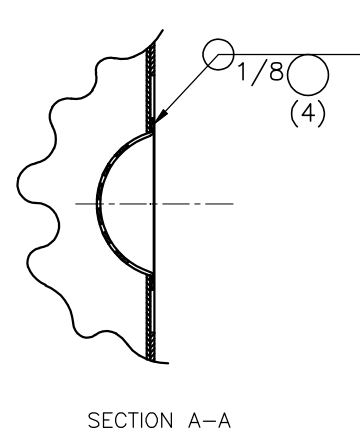
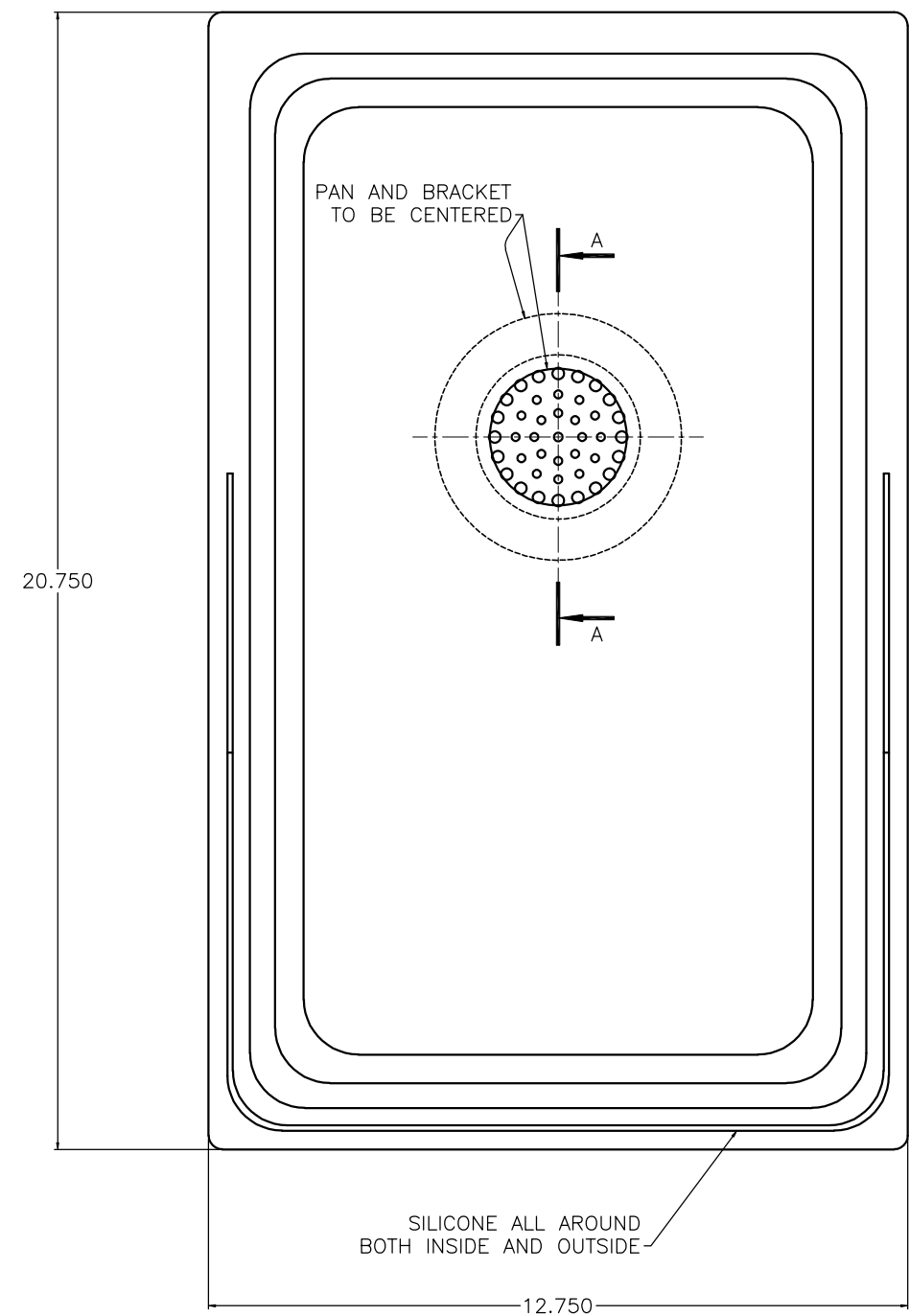

THIS DESIGN COVERS A PROPRIETARY ITEM AND IS THE PROPERTY OF CLEVELAND RANGE LTD. THIS DRAWING IS NOT TO BE COPIED OR USED WITHOUT THE APPROVAL OF CLEVELAND RANGE LTD.		FOR GENERAL TOLERANCES REFER TO PWI-043		CLEVELAND RANGE LTD. 8251 KEELE STREET, CONCORD, ONTARIO, CANADA		TITLE SLIDING DRAIN PAN ALL SD MODELS	
MATERIAL TYPE & GRADE		DO NOT SCALE PRINTED DRAWING		DRAWN BY		DATE 9/13/2006	
FORM SIZE FINISH						DRAWING NO. SDP-1	
						SHEET 1 OF 1	
						REV B	

Parts List			
ITEM	QTY	NAME	DESCRIPTION
1	1	SD50015	DRAIN PAN, MODIFIED
2	1	SD50016	PAN HOLDER BRACKET
3	1	SD50110-2	SPLASH GUARD
4	1	SK50003	BEEHIVES

FOR SERVICE (USED UNTILL 9/06)

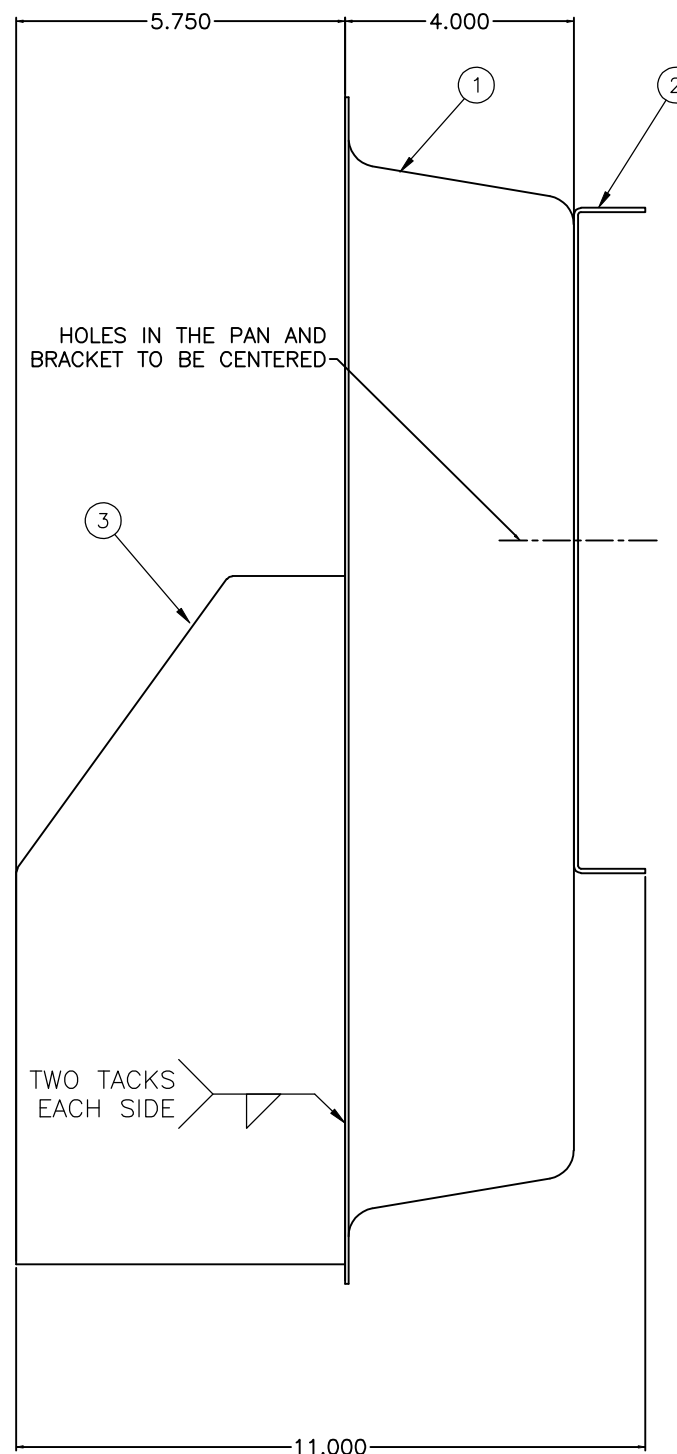
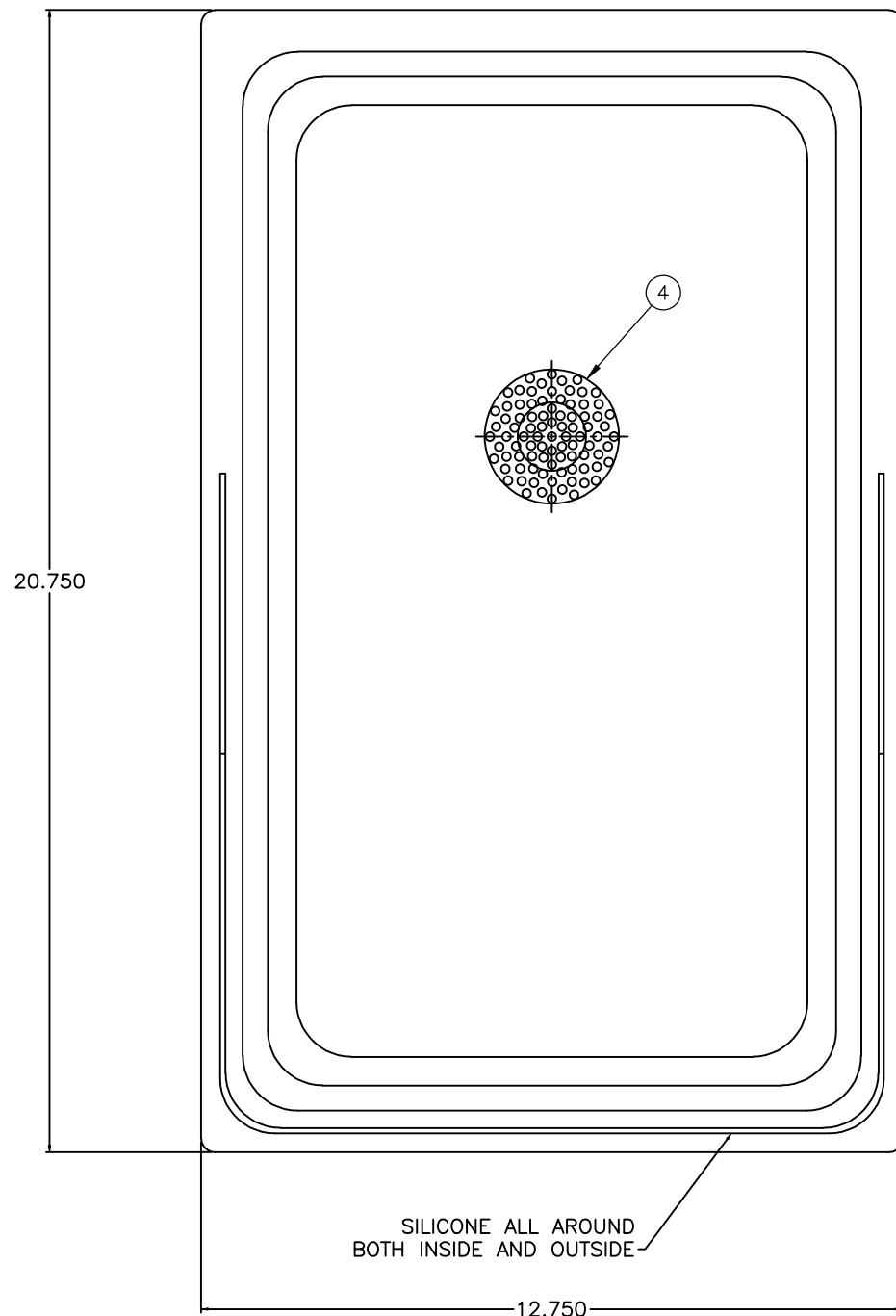

THIS DESIGN COVERS A PROPRIETARY ITEM AND IS THE PROPERTY OF CLEVELAND RANGE LTD. THIS DRAWING IS NOT TO BE COPIED OR USED WITHOUT THE APPROVAL OF CLEVELAND RANGE LTD.		FOR GENERAL TOLERANCES REFER TO PWI-043		CLEVELAND RANGE LTD. 8251 KEELE STREET, CONCORD, ONTARIO, CANADA		TITLE SLIDING DRAIN PAN ALL SD MODELS, SERVICE, JULY 20006	
MATERIAL TYPE & GRADE FORM SIZE FINISH		DO NOT SCALE PRINTED DRAWING		DRAWN BY DATE 9/13/2006		DRAWING NO. SDP.dwg	
						SHEET 1 OF 2 REV A	

Rigid to Swivel Adapter 113343

LET.	REVISIONS	DATE	BY
A	REMOVED PINS 14428, 14604, 14427, 14318;	04-16-94	EAG
-	ADDED PINS 23098, 23181, 06217, 106931	-	-
-	PIN 03606 WAS 03612, PIN 02559 WAS 02575	-	-
-	PIN 03627 WAS QTY(9) PIN 05280 WAS QTY (4)	-	-
-	PIN 06199 WAS QTY (2), EO C-2611	-	-
-	REDRAWN AUTOCAD - NO CHANGES	07-18-03	RJP

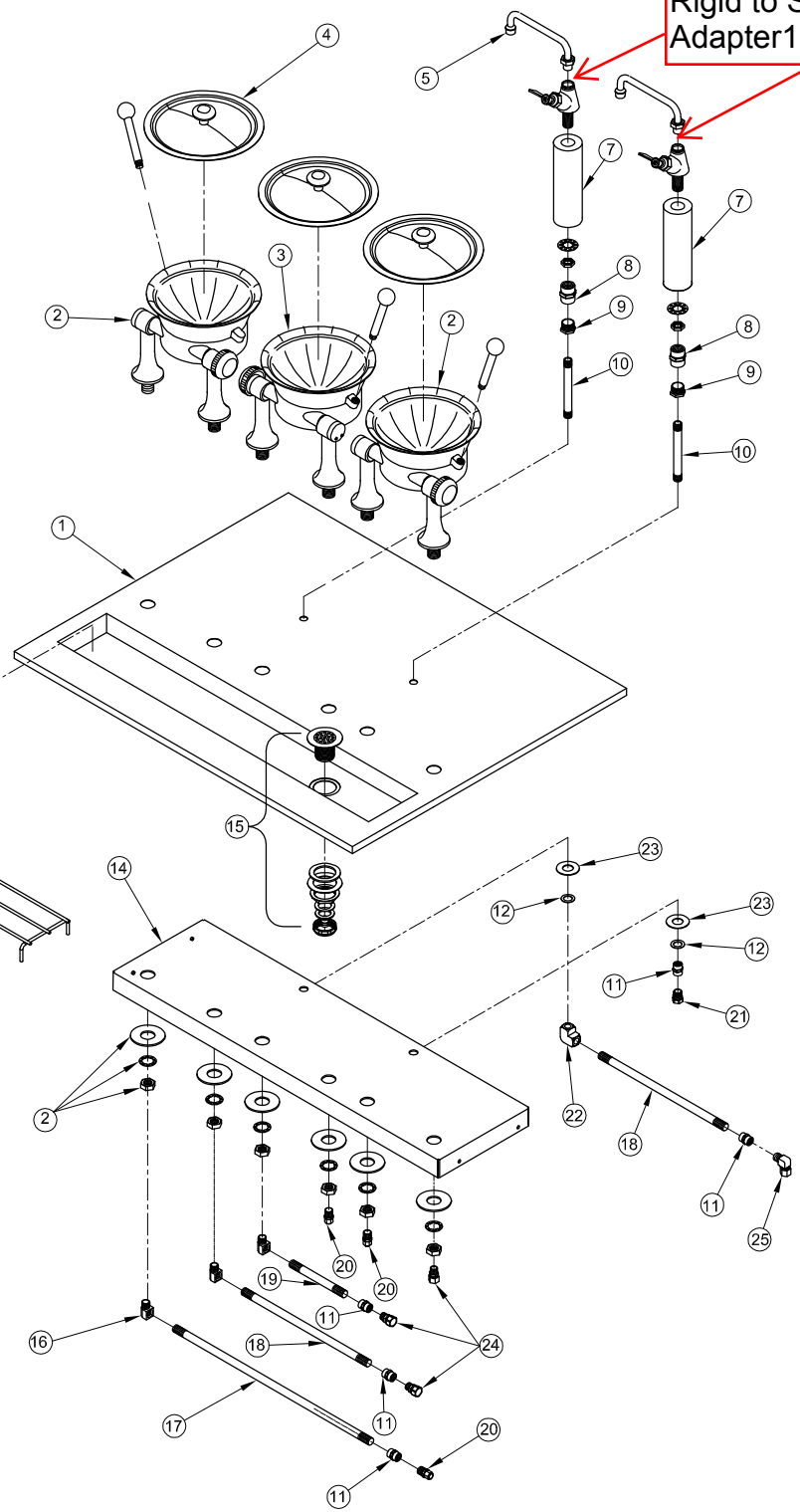

9.875" X 9.875" Trough Rack 40410

26	A/R	00934	SEALANT, RECTORSEAL
25	1	06217	FITTING, COMP. 90°, 3/8T X 3/8 MPT
24	3	06202	FITTING, COMPRESSION, 1/2T X 3/8 MPT STR
23	2	23181	WASHER, 15/16 ID X 2" OD, SIS, YOKE
22	1	05244	ELBOW, 90°, 3/8" BRASS
21	1	06199	FITTING, COMPRESSION, 3/8T X 3/8 MPT STR
20	3	06193	FITTING, COMPRESSION, 1/4T X 3/8 MPT STR
19	1	14436	NIPPLE, 3/8 X 6-1/2", BRASS
18	2	14430	NIPPLE, 3/8" X 14
17	1	14457	NIPPLE, 3/8" X 24" BRASS
16	RD	05280	ELBOW, STREET, 3/8" BRASS
15	1	105280	DRAIN ASSEMBLY, FITTING HOSE ADAPTER
14	1	105653	CROSSMEMBER WELDMENT, OYSTER BAR, 1050MM
13	1	105687	RACK WELDMENT, TROUGH, OYSTER BAR, 1050MM
12	2	23098	WASHER, FLAT, .750 ID X 1.188 OD
11	5	03627	COUPLING, 3/8" BRASS
10	2	106931	NIPPLE 3/8" X 6" BRASS
9	2	02559	BUSHING, REDUCING, 1/2" X 3/8"
8	2	03606	COUPLING, FULL, 1/2", BRASS
7	2	105656	RISER, WELDMENT, WATER FILL, OYSTER BAR
6	2	06118	FAUCET, SINGLE AAA
5	2	06107	NOZZLE, FAUCE, 8" W/SWIVEL BODY
4	3	CL1	COVER, LIFT OFF, OYSTER KETTLE
3	1	KD11TL	KETTLE, OYSTER, LEFT SIDE HANDLE, 1 GAL
2	2	KD11T	KETTLE, OYSTER, 1 GAL
1	1	106749	TABLE TOP, WELD, 1050MM, OYSTER BAR 3 KET

ITEM	QTY	PART NO.	DESCRIPTION
CLEVELAND RANGE, LLC 1333 East 179th St., Cleveland, Ohio 44110-2574			
<small>THIS DESIGN DESCRIBES A PROPRIETARY ITEM WHICH IS THE PROPERTY OF CLEVELAND RANGE. THIS DRAWING IS NOT TO BE COPIED OR USED WITHOUT THE APPROVAL OF CLEVELAND RANGE.</small>			
TOLERANCES (UNLESS OTHERWISE NOTED)		DO NOT SCALE PRINTED DRAWING	DRAWN BY E. GRIVEAS DATE 09-14-93
DECIMAL	±	TITLE OYSTER BAR, UPPER ASSEMBLY 3 KETTLE- 1050 MM GAS/ELECTRIC	
ANGULAR	±	SIZE C DRAWING NO. JMF0016	SHEET 1 OF 1 REV -

NEXT ASSY: JBF0017 JFF0020

splash guard 69615

Knob UR50083

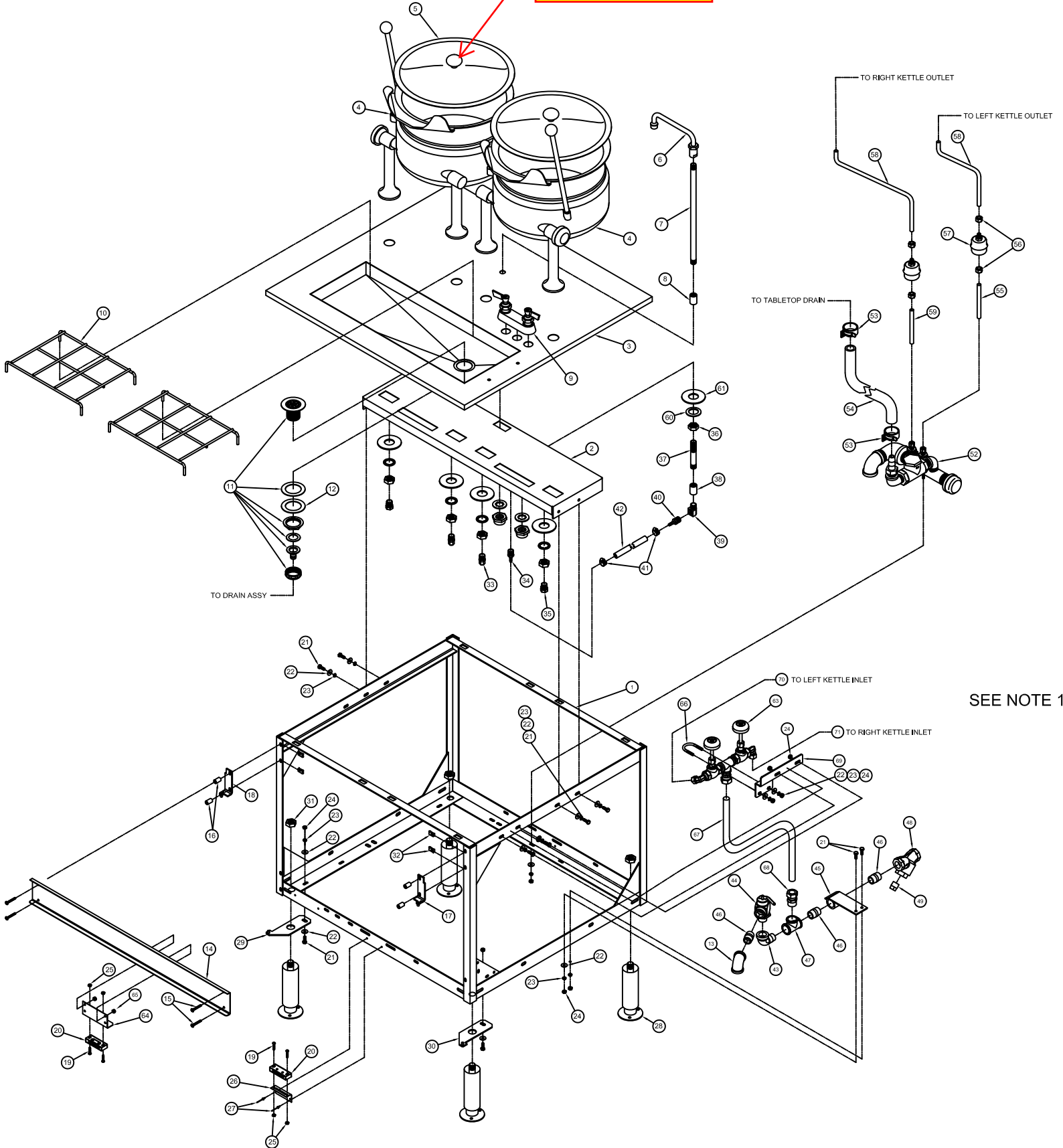

SEE NOTE 1

ITEM	QTY	PART NO.	DESCRIPTION
71	1	113222	TUBE, COPPER, 1/2 X 33.375
70	1	113221	TUBE, COPPER, 1/2 X 22.426
69	1	110872	BRACKET, VALVE SUPPORT, K1010
68	1	06208	FITTING
67	1	113223	TUBE, COPPER, 3/4 X 20.532
66	1	105970	U-BOLT, 1/4-20
65	2	14692	NUT, 10-24
64	1	102535	BRACKET, MAGNET MTG.
63	1	110983	VALVE ASSY, K1010
62	1	00934	SEALANT, PIPE DOPE
61	1	23181	WASHER, FLAT, .398 ID x 2.00 OD x .06 THK
60	1	23099	WASHER, FLAT, .750 ID x 1.188 OD x .05 THK
59	1	007280250	TUBE, COPPER, 1/4 x 2.500
-	1	007282800	TUBE, COPPER, 1/4 x 28.000 (RIGHT KETTLE)
58	1	007282300	TUBE, COPPER, 1/4 x 32.000 (LEFT KETTLE)
57	2	101207	TRAP, THERMOSTATIC, 1/4
56	4	14661	NUT, COMPRESSION FTG, 1/4 TUBE
55	1	007280250	TUBE, COPPER, 1/4 x 2.500
54	1	085112300	HOSE, WHITE EPDM, 3/4 x 23.000
53	2	03204	CLAMP, WORM DRIVE, 0.812-1.500
52	1	1048662	DRAIN MANIFOLD ASSEMBLY
-	1	00731675	TUBE, COPPER, 1/20D, 16.75 (LEFT KETTLE)
51	2	007312200	TUBE, COPPER, 1/20D, 22 (RIGHT KETTLE)
50	2	06187	FITTING, COMPRESSION, 1/2T x 3/4MPT, 90DEG.
49	1	16602	PLUG, SQ HD, 1/2 BLACK
48	1	19672	STRAINER, Y, 3/4 NPT
47	2	20205	TEE, 3/4, BLK
46	3	14343	NIPPLE, 3/4 x CLOSE, BLACK
45	1	100659	BRACKET, PTO MTG
44	1	SKE54941-2	VALVE, SAFETY, 3/4, 50 PSI
43	2	05239	ELBOW, STREET, 3/4, 90 DEG, BLK
42	1	1058601600	HOSE, NYLON REINFORCED, 1/4ID x 16.000
41	2	106526	CLAMP, WORM DRIVE, .25-.625 DIA.
40	1	104382LL	FITTING, HOSE BARB, 1/4H x 3/8MPT
39	1	05244LL	ELBOW, STREET, 3/8, BRASS
38	1	03627LL	COUPLING, 3/8, BRASS
37	1	14428	NIPPLE, 3/8 x 4, THREAD PER DWG
36	1	14604	NUT, LOCK, 3/8NPT

SEE NOTE 1

35	2	06202	FITTING, COMPRESSION, 1/2T x 3/8MPT
34	1	104381LL	FITTING, HOSE BARB, 1/4H x 1/4MPT
33	2	06193	FITTING, COMPRESSION, 1/4T x 3/8MPT
32	4	108734	NUT, U TYPE (EXTRUDED) 10-24
31	4	14668	NUT, HEX, JAM, 3/4-10 ZINC PLTD
30	1	1020663	HINGE, LOWER RIGHT
29	1	1020662	HINGE, LOWER LEFT
28	4	06162	FOOT, ADJ, FLANGED
27	2	18358	RIVET, 1/8 DIA, FLUSH BREAK
26	1	532741	BRACKET, MAGNET MOUNTING
25	4	14674	NUT, HEX, 6-32, ZINC PLTD.
24	10	14618	NUT, HEX, 1/4-20 SST
23	12	23105	WASHER, LOCK, 1/4 SPLIT RING
22	12	23116	WASHER, FLAT, 1/4 x 5/8 x .065
21	8	19288	SCREW, HEX HD, 1/4-20 x 0.750
20	2	03100	CATCH, MAGNETIC
19	4	19206	SCREW, RD HEAD, 6-32 x 1.00 ZINC PLTD.
18	1	412192	HINGE, UPPER LEFT
17	1	412192	HINGE, UPPER RIGHT
16	4	19555	SPACER, 0.812 LG
15	4	106698	SCREW, TRUSS HD, PHILLIPS, 10-24 x 1.500
14	1	1051342	CONSOLE, 900MM, PLAIN
13	1	05258	ELBOW, 90, 3/4 BLK
12	1	100728	WASHER, TROUGH DRAIN
11	1	106737	DRAIN ASSY, STD
10	2	41409	PACK, DRAIN GRID, 10 INCH SQUARE
9	1	06125	FAUCET, MIXING, HOT & COLD, TABLETOP MOUNT
8	1	03666	COUPLING, FULL, 3/8, SST
7	1	144301	NIPPLE, 3/8 x 1/4, CHROME PLTD.
6	1	06107	SPOUT ASSY, W/ SWIVEL BODY, 8 INCH
5	2	CL-10	KETTLE LID, 10 GALLON
-	1	SKDT10T316	KETTLE, 10 GALLON, 316 LINER NO COVER
4	1	SKDT10T	KETTLE, 10 GALLON, 304 LINER NO COVER
3	1	110874	TABLETOP, K1010
2	1	1016721	BRACE ASSY, KETTLE SUPPORT, 3/6 GALLON
-	1	1008823	BASE WELDMENT, 900MM, ALUM CTD, DC
1	1	40873	BASE WELDMENT, 900MM, SST, DC

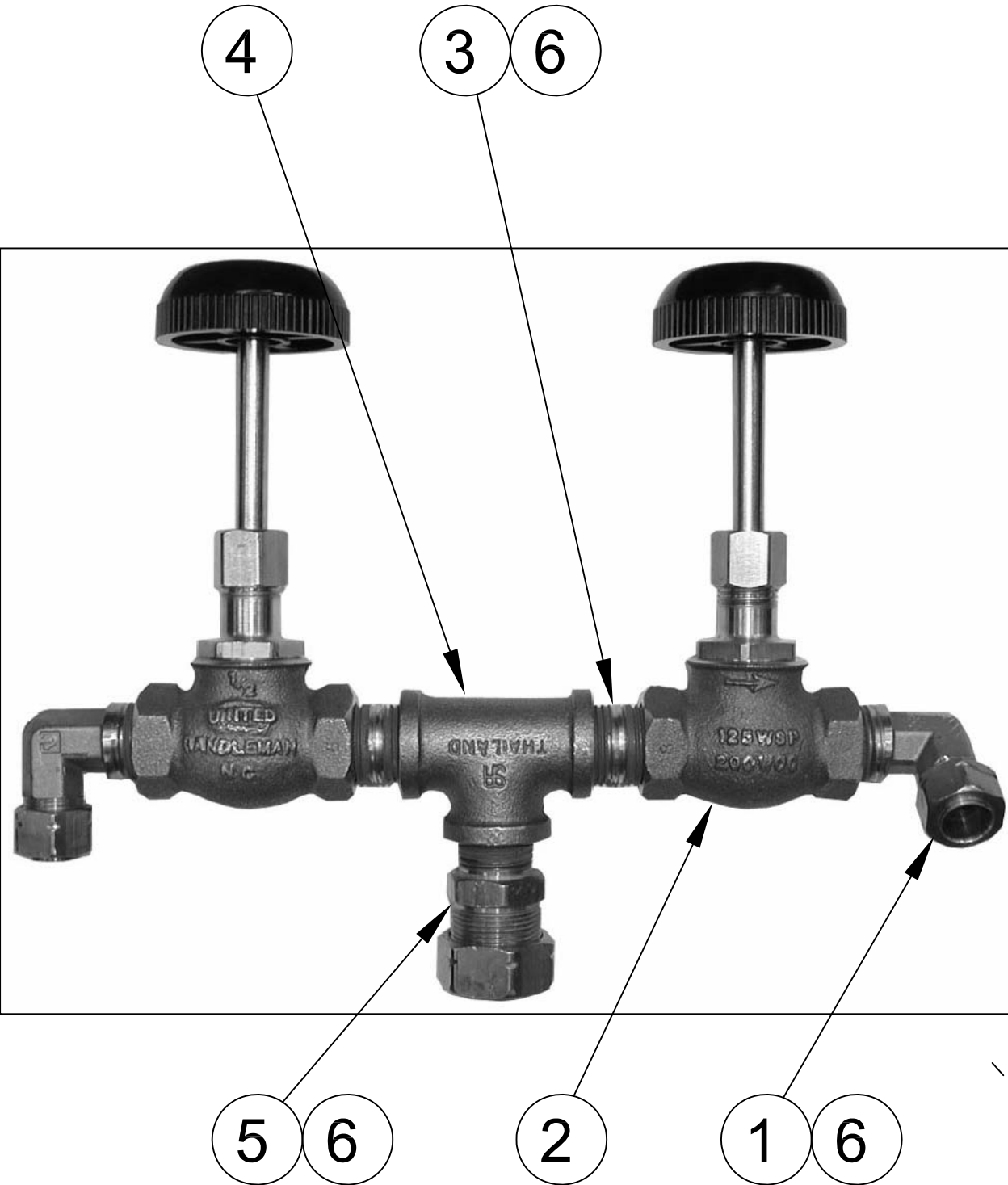

6	A/R	00934	SEALANT, PIPE DOPE
5	1	06207	FTG., COMPRESSION, 3/4T x 1/2MPT
4	1	20229	TEE, 1/2, BRASS
3	2	14324	NIPPLE, .50 x CLOSE, BRASS
2	2	22203	VALVE, GLOBE, 1/2 W/ 5.250 CHROME STEM
1	2	06205	FTG., COMPRESSION, 1/2T x 1/2MPT, 90°

SERVICE PARTS

ST Stands

Our Company supports a worldwide network of Maintenance and Repair Centers. Contact your nearest Maintenance and Repair Centre for replacement parts, service, or information regarding the proper maintenance and repair of your cooking equipment

In order to preserve the various agency safety certification (UL, NSF, ASME/Ntl. Bd., etc.), only factory-supplied replacement parts should be used. The use of other than factory supplied replacement parts will void warranty.

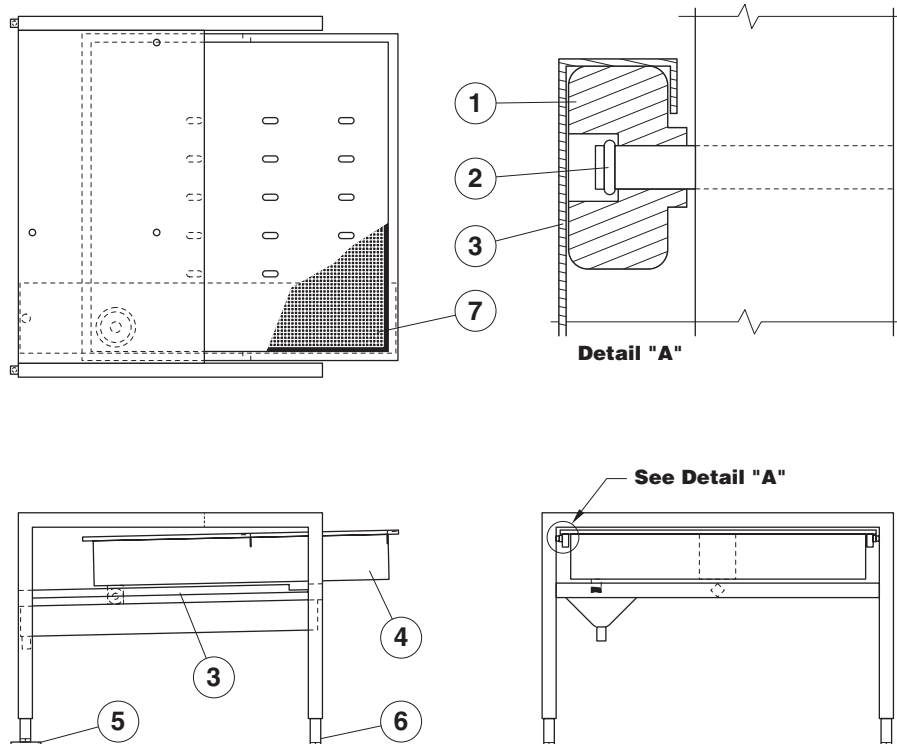

ITEM NO.	PART NO.	DESCRIPTION	QTY.				
			ST-28	ST-42	ST-55	EST-28	ST-28B
1.	ST50010	WHEEL, SLIDE	4	8	8	-	4
2.	FA95007-2	RETAINING RING	4	8	8	-	4
3.	ST50008-1	SLIDE, LHS	1	2	2	-	1
	ST50008-2	SLIDE, RHS	1	2	2	-	1
4.	ST00003-1	PAN, WELDMENT ASSEMBLY	1	-	2	-	1
	ST00003-2	PAN, WELDMENT ASSEMBLY	-	2	-	-	-
5.	STD00002	REAR FOOT ASSEMBLY	2	3	3	2	2
6.	STD50026	ADJUSTABLE FOOT	2	3	3	2	2
7.	KE02080-1	SPLASH SCREEN	1	-	2	-	1
	KE02080-2	SPLASH SCREEN	1	-	2	-	1

ADDING ADAPTOR TOP TO STAND

These instructions are for mounting an AK adaptor top to a ST-28 stand. The same procedure will be used for ST-42 and ST-55 stands and corresponding adaptor tops.

1. Remove all items from packaging.
2. Remove all protective plastic wrap.



3. Turn kettle upside down.
4. Remove washers, nuts and support brace.
5. Discard support brace.



6. Lift adaptor top and place kettle legs through holes.



7. Replace washers and nuts from kettle. Tighten.



8. Added reducing elbows.



9. Add plumbing nipples.



- 10.** Remove drawer and drawer slides.
- 11.** Turn stand upside down.
- 12.** Lift onto adaptor top.
- 13.** Align mounting holes with studs on adaptor top.
- 14.** Fasten with nuts and washers provided.



- 15.** Lower stand onto floor.



- 16.** Lift kettle up.
- 17.** Place stand in position.

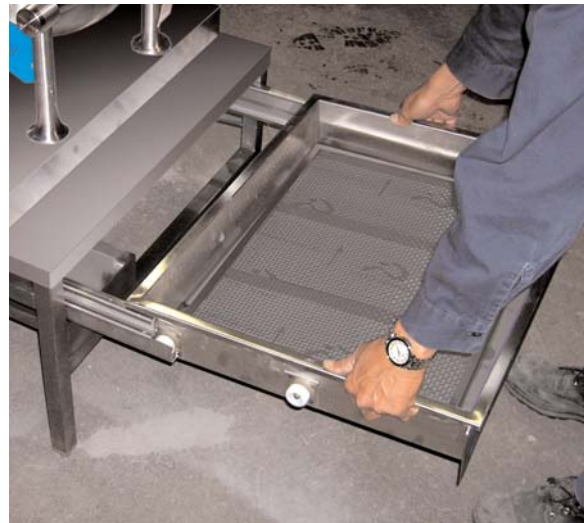

- 18.** Replace drawer slides and drawer.
- 19.** Bolt stand to floor.
- 20.** Add connection plumbing as required.



- 21.** Apply a bead of silicone between adaptor top and stand.

ADAPTOR TOP ASSEMBLY

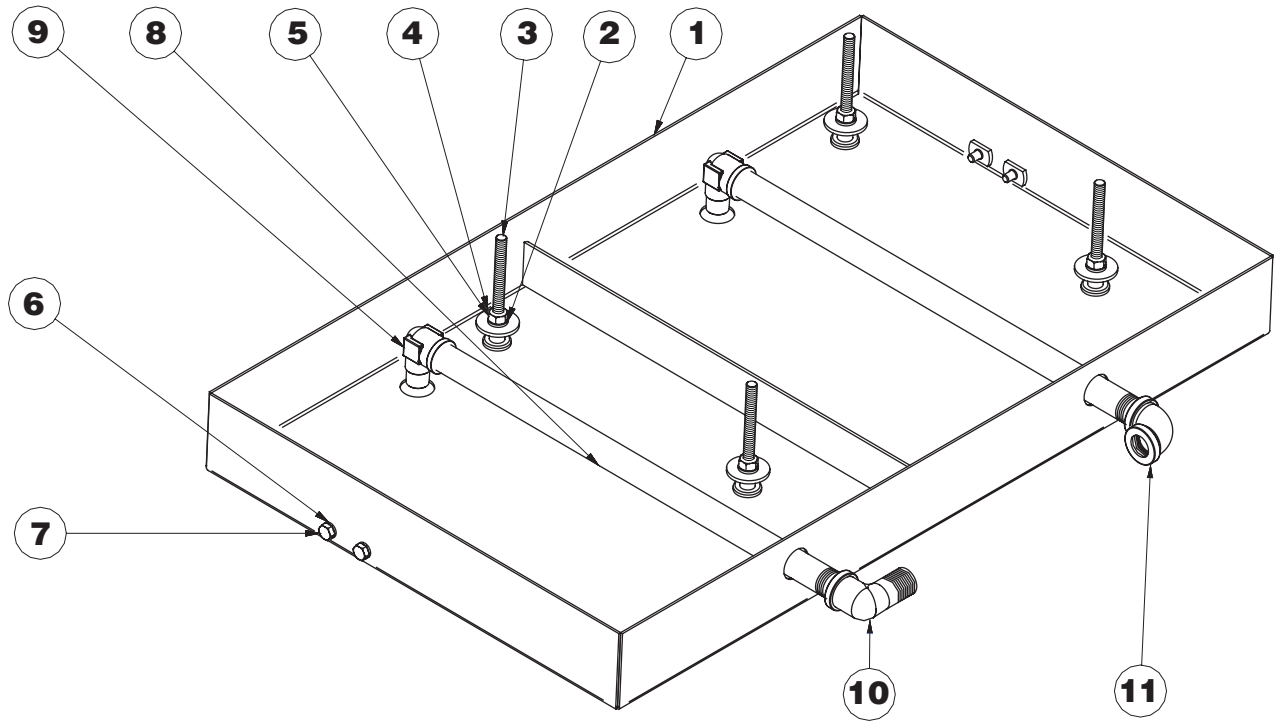

PART#	KE003607-1	KE003607-2	KE003607-3	KE003607-4		
MODEL	AK-6	AK-12	AK-20	AK-3		
FOR	KDT-6-T	KDT-12-T	KDT-20-T	KDT-3-T		
1	ST00007-1	1			FALSE TOP WELDMENT	
	ST00007-2		1		FALSE TOP WELDMENT	
	ST00007-3			1	FALSE TOP WELDMENT	
	ST00007-4				1	FALSE TOP WELDMENT
2	FA31030	4	4	4	SPLIT LOCKWASHER, 5/16, SS	
3	KE518903	4	4	4	STUD, 5/16-18 x 3 3/4	
4	FA30079	4	4	4	FLAT WASHER, .406 x 1.25 x 120	
5	FA21024	4	4	4	NUT, 5/16-18	
6	FA31029	4	4	4	SPLIT LOCKWASHER, 1/4, SS	
7	FA11257	4	4	4	HEX BOLT, 1/4-20 x 5/8, SS	
8	N0440G16.5	2			NIPPLE, 1/2"	
	N0440G15		2		NIPPLE, 1/2"	
	N0440G12			2	NIPPLE, 1/2"	
	N0440G16.5				2	NIPPLE, 1/2"
9	KE603610	2	2	2	BRASS REDUCING, 1/2" FNPT x 3/8" MNPT	
10	FI05025	1	1	1	ELBOW, 90° STREET, (FIP x MIP)	
11	FI05216	2	2	2	ELBOW, 90°, (FIP x FIR)	

FAUCET ASSEMBLIES

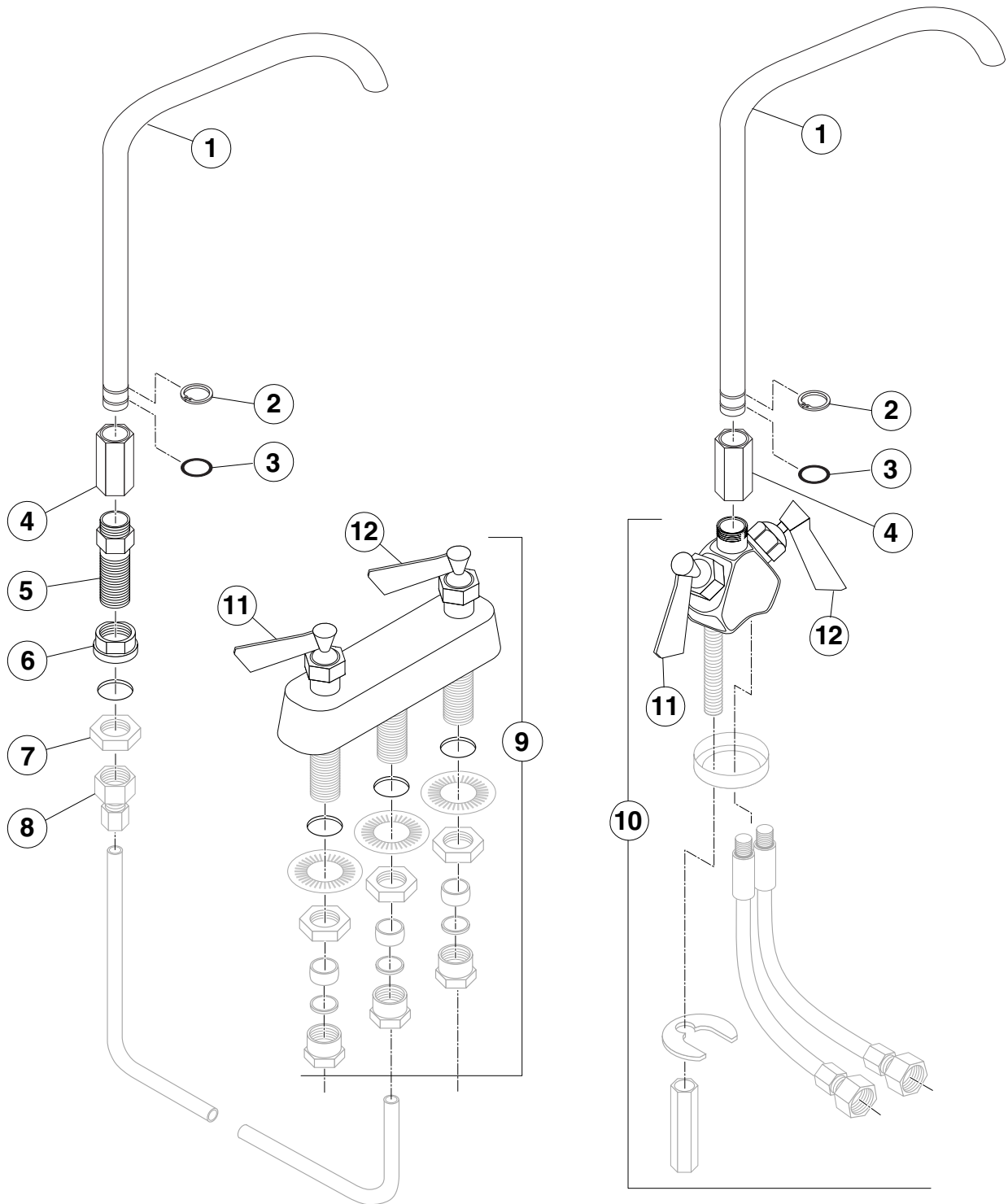

FAUCET ASSEMBLIES

ITEM NO.	PART NO.	DESCRIPTION	QTY.
1.	KE50825-8	6 gallon	1
	KE50825-1	12 gallon	1
	KE50825-1	20 gallon	1
2.	FA95022	Retaining Ring	1
3.	FA05002-19	"O" Ring	1
4.	KE51736	Long Faucet Nut	1
5.	SD50097	Flanged Nut, 3/4" NPT, Chrome Plated	1
6.	KE51585	Faucet Spout Fitting	1
7.	SD50098	Locknut, 3/4" NPT	1
8.	FI00266	Coupling, 1/2" NPT	1
9.	KE51899	Double Pantry Control Valve	1
		(c/w Item No. 11&12)	
10.	KE51403	Double Pantry Control Valve	1
		(c/w Item No. 11&12)	
	KE51401	Single Pantry Control Valve	1
		(c/w Item No. 12)	
11.	SE50020	Hot Water Stem Assembly	1
12.	SE50021	Cold Water Stem Assembly	1

STEAM CONTROL ASSEMBLY - FOR KETTLES WITH GEARBOX

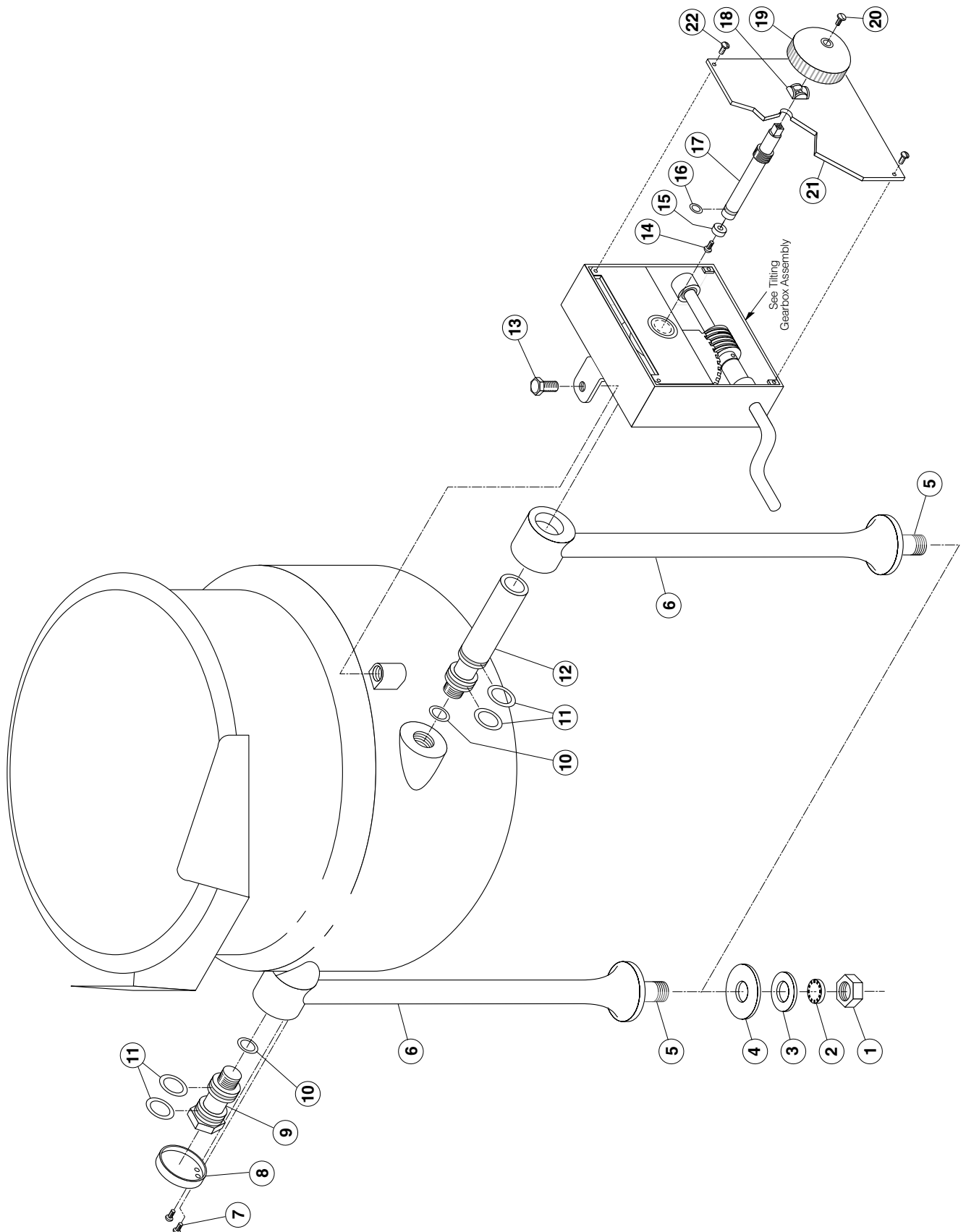

STEAM CONTROL ASSEMBLY -

FOR KETTLES WITH GEARBOX

ITEM NO.	PART NO.	DESCRIPTION	QTY.
1.	KE52697	Lock Nut, 1/2" NPS	.2
2.	FA32500	Lockwasher	.2
3.	FA30502	Washer, satin coat	.2
4.	KE50467	Washer, Foot	.2
5.	KE50463	Service Pipe	.2
6.	KE00203	Leg Assembly	.2
7.	FA11056	Binding Head Screw, 6-32 x 1/2" lg.	.2
8.	KE50458	End Cap, condensate return	.1
9.	KE50455-1	Trunnion, condensate return	.1
10.	FA05002-35	"O" Ring	.1
11.	FA05002-37	"O" Ring	.4
12.	KE54752	Trunnion	.1
13.	FA11509-1	Bolt, 1/2-13 x 3/4" lg	.1
14.	FA11089	Binding Head Screw, 8-32 x 1/4" lg.	.1
15.	KE51713	Washer, steam valve	.1
16.	FA05002-12	"O" Ring	.1
17.	KE54753	Operating Stem	.1
18.	KE51888	Retaining Washer	.1
19.	SE00028	Steam Control Knob (includes Item #18 & 20)	.1
20.	FA11092	Binding Head Screw, 8-32 x 1/2" lg.	.1
21.	KE54729	Gear Box Cover	.1
22.	FA11146	Binding Head Screw, 8-32 x 3/8"	.4

TILTING GEARBOX ASSEMBLY - FOR KETTLES WITH GEARBOX

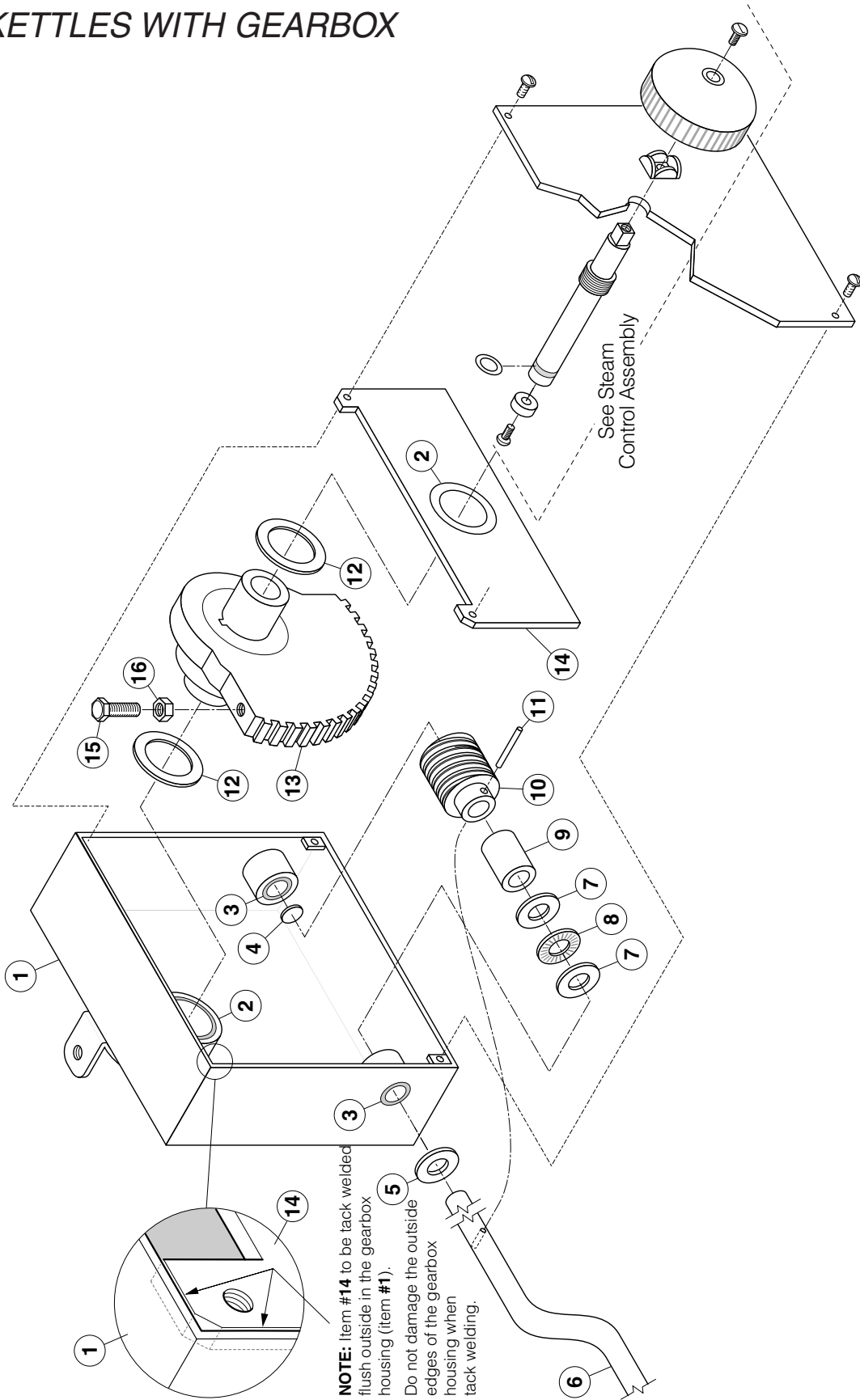

TILTING GEARBOX ASSEMBLY -

FOR KETTLES WITH GEARBOX

ITEM NO.	PART NO.	DESCRIPTION	QTY.
1.-16.	KE02062-1	Tilting Gearbox Assembly	1
1.	KE02060	Gearbox Housing	1
2.	KE50198	Bearing, trunnion	2
3.	KE54739-2	Bearing, tilt shaft	2
4.	KE54737	End Housing Spacer, tilt shaft, bronze	1
5.	KE54738-3	Washer	1
6.	KE50306-1	Tilt Shaft	1
7.	KE52192	Bearing Washer	2
8.	KE52191	Bearing	1
9.	KE50426-3	Spacer, Tilt Shaft	1
10.	KE50315	Worm Gear	1
11.	FA95005	Tension Pin	1
12.	KE54738-1	Washer	2
13.	KE02059	Segment Gear and Spacer Assembly	1
14.	KE02061	Trunnion Bearing Housing Holder Assembly c/w Bearing	1
15.	FA10485	Hex Head Bolt	1
16.	FA20008	Hex Nut	1

MAINTENANCE

ALL SERVICE MUST BE PERFORMED BY A QUALIFIED SERVICE TECHNICIAN.

This kettle requires very little preventative maintenance other than daily cleaning. The pressure relief valve must be tested twice a year.

PRESSURE RELIEF VALVE TESTING PROCEDURE

WARNING
Kettle will be hot. Use gloves for protection.

The pressure relief valve (optional on kettles) must be checked at least twice a year as part of the normal maintenance performed.

- 1.** Open steam valve and preheat kettle.
- 2.** Stand to the side of the pressure relief valve discharge tube and pull ring three or four times to insure free movement. Hold valve open for two seconds each time, insuring there is rapid steam escape each time.
- 3.** If valve appears to be sticking replace pressure relief valve. If foreign material is discharged, replace pressure relief valve and eliminate the source of contamination.

STEAM TRAP

To remove line condensate that forms inside the steam jacket, each kettle should be equipped with a steam trap in the line of the kettle outlet to the drain. A good steam trap at startup releases air and wet steam into the drain line for a few minutes, then holds the steam jacket. During cooking, the trap periodically releases accumulated condensate. If the kettle's cooking performance becomes inadequate after long use, replacement of the steam trap with a new one may restore kettle operation to peak efficiency.

MARINE LOCK

Inspect lock at least twice yearly.

- 1.** Check for excessive play or wear on pivot. Adjust or replace as required.
- 2.** Insure lock is catching over the centre of the stop pin and not bent to one side or the other. Adjust or replace as required.

WARRANTY

Our Company supports a worldwide network of Maintenance and Repair Centers. Contact your nearest Maintenance and Repair Centre for replacement parts, service, or information regarding the proper maintenance and repair of your cooking equipment

In order to preserve the various agency safety certification (UL, NSF, ASME/Ntl. Bd., etc.), only factory-supplied replacement parts should be used. The use of other than factory supplied replacement parts will void warranty.

TROUBLESHOOTING GUIDE

This section contains information intended for use by Authorized Service Personnel only.

PROBLEM

A/ Kettle heats too slowly or does not come to a boil.

Probable Cause

1. Inadequate steam flow.
2. Steam trap not operating properly.
3. Food batches are not always the same.

Remedy

Check for correct steam using chart below.
 If kettle is connected to a steamer and powered by a generator the units should be operated sequentially (kettle boiling first, then start steamer).
 The trap should open periodically to dump condensate, then close.
 If it does not open or close it should be cleaned or replaced.
 When checking make certain that the original state (ie. fresh or frozen) and quantity of food product is the same.

PROBLEM

B/ The trunnion housing leaks steam.

Probable Cause

1. Trunnion "O" rings are worn.

Remedy

Replace "O" rings (see STEAM CONTROL ASSEMBLY drawing).

STEAM FLOW RATING OF STEAM GENERATORS

Gas Input BTU/Hour	Steam Output Lbs./Hour	Boiler H.P.
100,000	60	1.7
160,000	95	2.8
200,000	125	3.6
250,000	150	4.4
300,000	180	5.2
Electric KW Input		
18	60	1.7
24	70	2.0
27	90	2.6
36	120	3.5
48	150	4.4

STEAM FLOW RATING REQUIREMENTS FOR KETTLES

Capacity Gal./Lit.	Fast Cooking	Medium Cooking	Stock Kettle
5/17	11	9	6
10/42	22	18	11
25/95	55	44	28
40/151	88	70	44
60/227	132	105	66
Electric: Above shows lbs. per hour with 10-15 psig steam at the kettle. The use of higher steam pressures (20-25 psig) will reduce heat-up time 5-20%.			

SPECIFICATION DRAWINGS

KDT-1-T

CLEARANCE REQUIREMENTS TO COMBUSTIBLE AND NONCOMBUSTIBLE SURFACES:

Right - 4" Left - 0 Back - 0

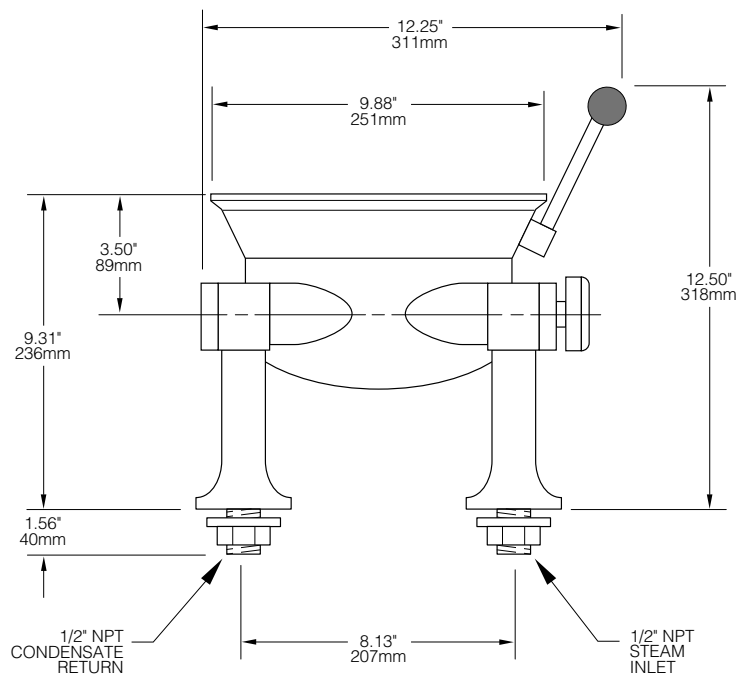
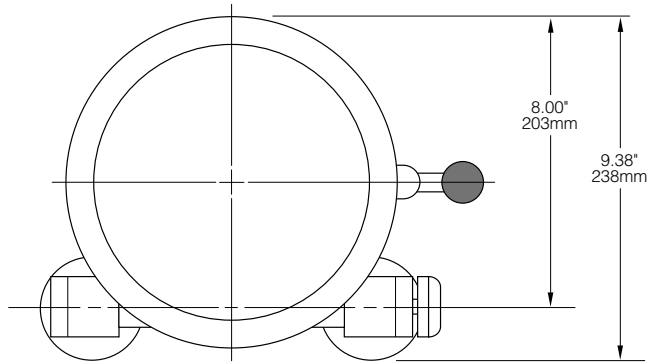

KDT-3-T & KDT-6-T

CLEARANCE REQUIREMENTS TO COMBUSTIBLE AND NONCOMBUSTIBLE SURFACES:

Right - 4" Left - 4" Back - 1"

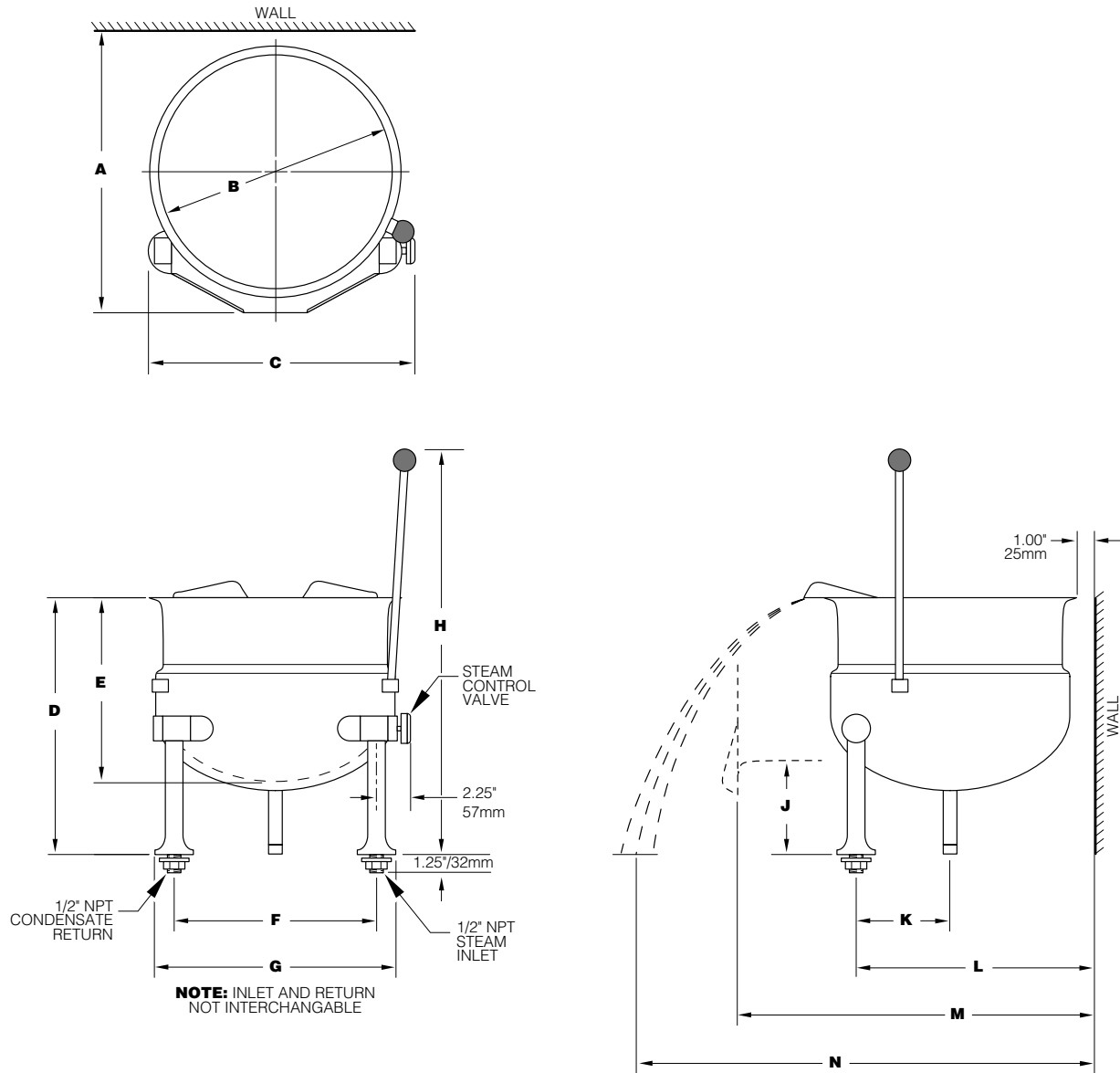

GAL.	LITRE		A	B	C	D	E	F	G	H	J	K	L	M	N
3	11	IN	14.00	10.00	15.13	12.50	8.25	10.00	12.50	23.00	7.00	4.00	11.00	15.00	21.00
		mm	356	254	384	317	210	254	317	584	178	102	279	381	533
6	23	IN	17.50	13.38	15.13	15.31	11.00	12.00	14.50	24.50	6.75	6.00	14.50	21.19	27.50
		mm	445	400	384	389	279	305	368	622	171	152	368	538	699

KDT-12-T & KDT-20-T

CLEARANCE REQUIREMENTS TO COMBUSTIBLE AND NONCOMBUSTIBLE SURFACES:

Right - 4" Left - 4" Back - 1.75"

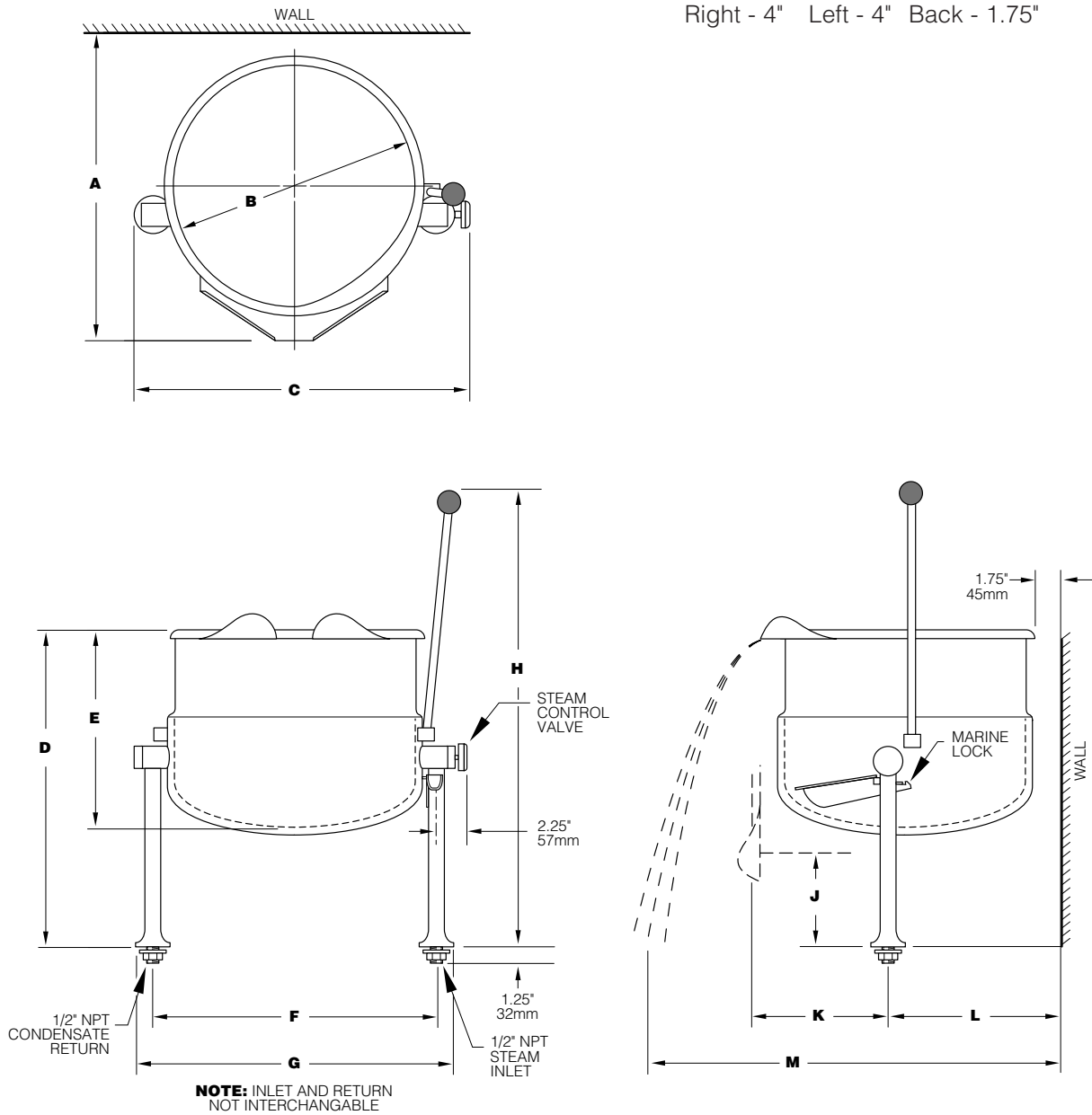

GAL.	LITRE		A	B	C	D	E	F	G	H	J	K	L	M
3	11	IN	20.50	16.75	23.00	22.25	13.50	19.50	22.00	29.00	6.00	8.75	11.50	29.50
		mm	521	425	584	565	343	495	559	737	152	222	292	749
6	23	IN	25.25	21.00	27.25	18.00	11.00	23.75	26.25	33.00	6.50	10.50	13.25	36.75
		mm	641	533	692	457	279	603	667	838	165	267	337	960

SD STANDS WITH KETTLES

CLEARANCE REQUIREMENTS TO COMBUSTIBLE AND NONCOMBUSTIBLE SURFACES:

Right - 0 Left - 0 Back - 0

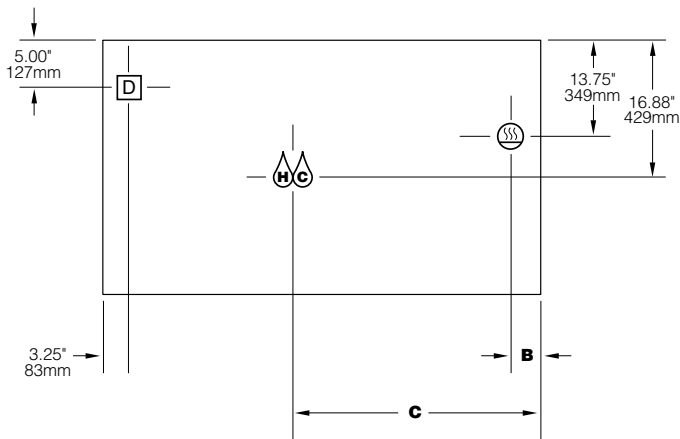

MODEL	A	B	C
SD-450- K 6	17.70 450	4.00 102	10.00 254
SD-650- K12	25.56 650	4.00 102	13.75 349
SD-760- K12	29.94 760	5.22 133	15.00 381
SD-760- K20	29.94 760	3.10 79	15.00 381
SD-1050- K20	41.32 1050	6.50 165	34.75 883
SD-1050- K 6 6	41.32 1050	4.91 125	20.66 525
SD-1200- K 6 12	47.19 1200	4.10 104	19.84 504
SD-1600- K 6 20	63 1600	9.88 251	25.63 651
SD-1600- K 12 12	63 1600	8.25 210	31.50 800
SD-1600- K 12 20	63 1600	6.13 156	29.38 746
SD-1600- K 20 20	63 1600	4.00 102	31.50 800

