

Project _____
 Item _____
 Quantity _____
 FCSI Section 11400 _____
 Approved _____
 Date _____

TABLE TYPE, DIRECT STEAM
 TILTING, 2/3 STEAM JACKETED
 3 OR 6 GALLONS (11 OR 23 LITERS)

Models

- KDT-3-T
- KDT-6-T



Standard Features

- Type 304 Stainless Steel construction, with #4 finish on kettle and supports
- Manual Tilting, balanced design
- Mounting Lugs for Tilt Handle provided on both sides
- High capacity Pouring Lip
- 50 psi Steam Jacket Rating
- 50 psi chrome plated Safety Valve
- Steam Control Valve
- Typical approvals include NSF and ASME

Options & Accessories

- Type 316 Stainless Steel kettle interior for high acid food products (316)
- Kettle stand or table (ST28)
- Food Strainers (FS)
- Steam Pressure Reducing Valve, where supply pressure exceeds 45 psi (PRV)
- Steam Condensate Trap and Strainer, chrome plated
- Steam supply Moisture Separator/Trap (MS)
- Single or Double Pantry Faucet with Swing Spout (SPK or DPK)
- Steam Control Kit: includes Steam Trap, Condensate Strainer, Check Valve, nipples and fittings (SCK2)
- One piece, Lift-off Cover (CL-)
- Adapter Top, required when mounting to ST28 Stand (AK)

Short Form Specifications

Shall be CLEVELAND, Direct Steam Kettle, Table mounted, Tilting; Model KDT - ____ - T, ____ gallons, Tilting 2/3 Steam Jacketed. Type 304 Stainless Steel kettle and supports. 50 psi Steam Jacket Rating; Steam Control Valve. Trunnion mounted, self-lubricated Steam Control Valve. (Table not included.)

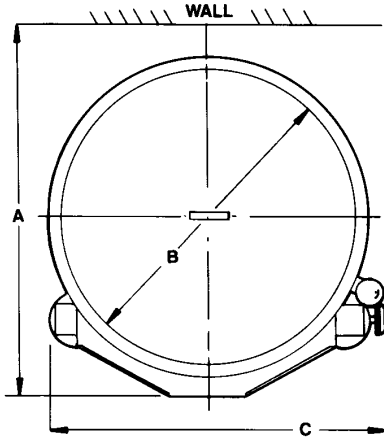

CAPACITIES: (in 4 oz. servings,
other sizes may be calculated.)
3 Gallon / 11 liters . . . 48 servings
6 Gallon / 23 liters . . .160 servings

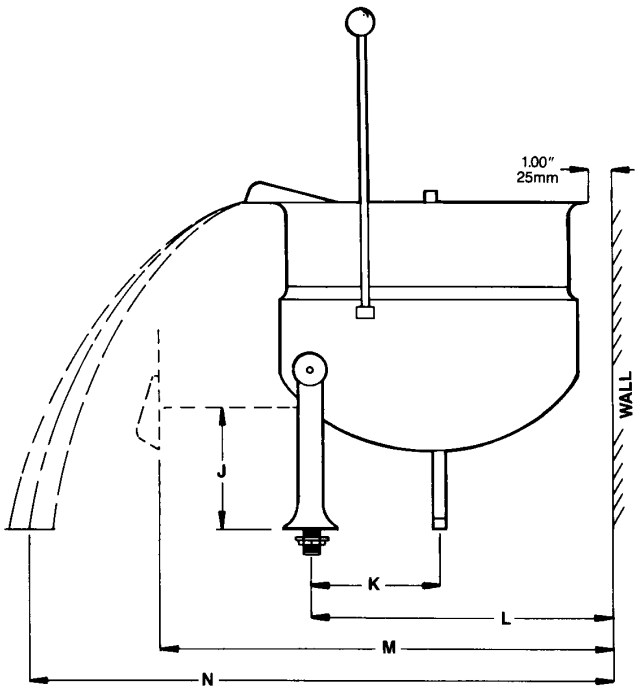
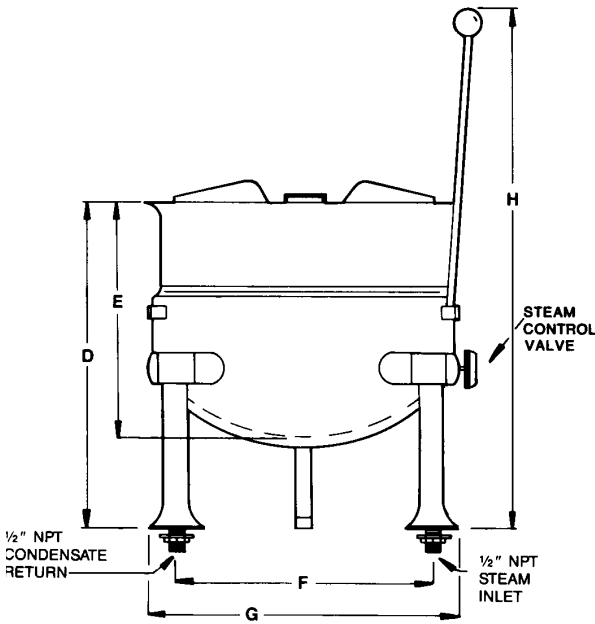

NOTE: INLET AND RETURN NOT INTERCHANGEABLE

GALS.	LITER		A	B	C	D	E	F	G	H	J	K	L	M	N
3	11	IN	14.00	10.00	15.13	12.50	8.25	10.00	12.50	23.00	7.00	4.00	11.00	15.00	21.00
		mm	356	254	384	317	210	254	317	584	178	102	279	381	533
6	23	IN	17.50	13.38	15.13	15.31	11.00	12.00	14.50	24.50	6.75	6.00	14.50	21.19	27.50
		mm	445	400	384	389	279	305	368	622	171	152	368	538	699

DIRECT STEAM	CLEARANCE
Steam Supply: Furnish 1/2" IPS minimum line. Operating pressure 5 to 45 psi with a 50 psi Safety Valve.	RIGHT=4.00" LEFT =4.00" REAR =1.00"

SHOWN WITH
OPTIONAL
MODULAR
CABINET BASE

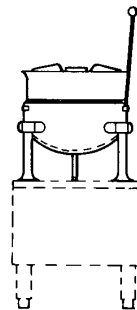

NOTES:

Cleveland Range reserves right of design improvement or modification, as warranted.
 Many regional, state and local codes exist and it is the responsibility of the owner and installer to comply with the codes.
 Installation of backflow preventers, vacuum breakers and other specific code requirements is the responsibility of the owner and installer.
 Cleveland Range equipment is built to comply with applicable standards for manufacturers. Included among those approval agencies are U.L., A.G.A., NSF, ASME/N.Bd., CSA, CGA, ETL and others.

(NOT TO SCALE)