

Project \_\_\_\_\_  
 Item \_\_\_\_\_  
 Quantity \_\_\_\_\_  
 FCSI Section 11400 \_\_\_\_\_  
 Approved \_\_\_\_\_  
 Date \_\_\_\_\_

**OYSTER KETTLE, DIRECT STEAM**  
 TILTING, TABLE TYPE, 2/3 STEAM JACKETED  
 80 OZ. (2.4 LITERS)

**Models**

- KDT-1-T



**Standard Features**

- Full 80 oz. (2.4 liter) capacity
- Unique, compact Steam Control Valve built into trunnion (standard right hand; left hand available at no extra charge)
- Kettle and all exterior surfaces are Stainless Steel for ease of cleaning (kettle exterior is mirror finish)
- Easy manual tilting — balanced design
- 50 psi Steam Jacket Rating
- 50 psi chrome plated Safety Valve
- Ideal for oyster stews, steamed clams, mussels, etc.
- Typical approvals include NSF and ASME

**Short Form Specifications**

Shall be CLEVELAND, Oyster Kettle, Direct Steam, Table type, Tilting; Model KDT-1-T, Type 304 Stainless Steel kettle and supports. 50 psi Steam Jacket Rating; Steam Control Valve. Trunnion mounted, self-lubricated Steam Control Valve. 80 OZ. (2.4 liter) capacity.

**Options & Accessories**

- Oyster Bars with 2, 3 or 4 Oyster Cookers mounted to a modular steam generator base
- Chrome plated Steam Control Kit (supplied loose) (SCK2)
- Lift-off Cover (CLI)
- Pressure Reducing Valve for regulating incoming steam pressure of over 45 psi (PRV-K)
- Double Pantry Faucet (DPK)
- Double Pantry Faucet (SPK)

CAPACITIES: (in 4 oz. servings,  
other sizes may be calculated.)  
80 oz. / 2.4 liters . . . 20 servings

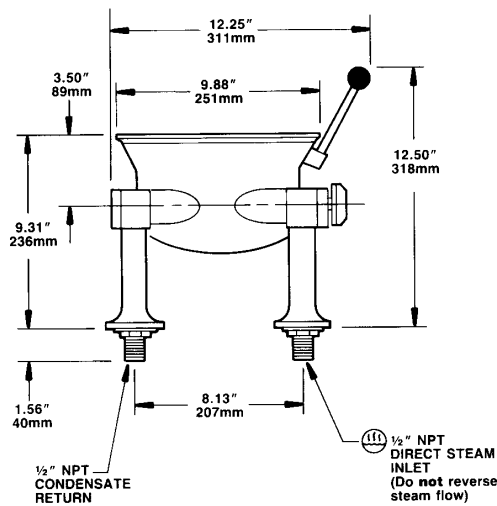
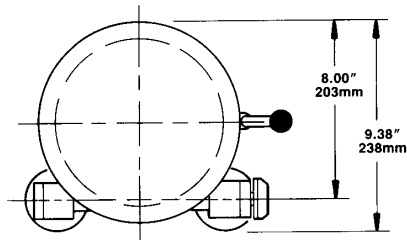

Direct Steam Kettles

DIRECT STEAM	CLEARANCE
Steam Supply: Furnish 1/2" NPT minimum line. Operating pressure 5 to 45 psi with a 50 psi Safety Valve.	RIGHT = 4.00" LEFT = 0" REAR = 0"

**NOTES:**

Cleveland Range reserves right of design improvement or modification, as warranted.  
 Many regional, state and local codes exist and it is the responsibility of the owner and installer to comply with the codes.  
 Installation of backflow preventers, vacuum breakers and other specific code requirements is the responsibility of the owner and installer.  
 Cleveland Range equipment is built to comply with applicable standards for manufacturers. Included among those approval agencies are U.L., A.G.A., NSF, ASME/N.Bd., CSA, CGA, ETL and others.

(NOT TO SCALE)