



Visit [www.clevelandrange.com](http://www.clevelandrange.com) to locate a service or sales representative in your area.



# Modular Direct Steam Kettles

## Installation, Operation, Maintenance, Parts & Service

This manual is updated as new information and models are released. Visit our website for the latest manual.

### MODELS:

KDM-T

*For your future reference.*

Model # \_\_\_\_\_

Serial # \_\_\_\_\_



Model # & Serial #.



**Read the manual thoroughly.**  
**Improper installation, operation or maintenance can cause property damage, injury or death.**

### TABLE OF CONTENTS

Statement of Responsibilities .....	1
For your Safety .....	2
Installation .....	4
Operating Instructions .....	6
Cleaning Instructions .....	7
Preventative Maintenance .....	8
Maintenance .....	9
Service Parts .....	11



# **STATEMENT OF RESPONSIBILITIES / DÉCLARATION DES RESPONSABILITÉS / DECLARACIÓN DE RESPONSABILIDADES**

This document is for use by experienced and trained Qualified Cleveland Range, LLC Authorized Service Representatives who are familiar with both the safety procedures, and equipment they service. Cleveland Range, LLC assumes no liability for any death, injury, equipment damage, or property damage resulting from use of, improper use of, or failure to use the information contained in this document. Cleveland Range, LLC has made every effort to provide accurate information in this document, but cannot guarantee that this document does not contain unintentional errors and omissions.

The information in this document may be subject to technical and technological changes, revisions, or updates. Cleveland Range, LLC assumes no liability or responsibility regarding errata, changes, revisions, or updates.

Qualified Cleveland Range, LLC Authorized Service Representatives are obligated to follow industry standard safety procedures, including, but not limited to, OSHA regulations, and disconnect / lock out / tag out procedures for all utilities including steam, and disconnect / lock out / tag out procedures for gas, electric, and steam powered equipment and / or appliances.

All utilities (gas, electric, water and steam) should be turned OFF to the equipment and locked out of operation according to OSHA approved practices during any servicing of Cleveland Range equipment

Qualified Cleveland Range, LLC Authorized Service Representatives are obligated to maintain up-to-date knowledge, skills, materials and equipment.

Ce document est destiné à l'usage des Représentants de Service qualifiés et autorisés de Cleveland Range, LLC qui possèdent l'expérience et la formation ainsi que la bonne connaissance des mesures de sécurité et du matériel qu'ils entretiennent.

Cleveland Range, LLC décline toute responsabilité pour tout cas de décès, blessure, dommage matériel ou dommage aux biens résultant de l'utilisation, de la mauvaise utilisation ou du manquement d'utilisation des renseignements contenus dans ce document.

Cleveland Range, LLC s'est efforcé à fournir des renseignements précis dans ce document mais ne peut garantir que ce document soit exempt d'erreurs et d'omissions non intentionnelles.

Les renseignements contenus dans ce document peuvent être assujettis à des changements techniques et technologiques, des révisions ou des mises à jour.

Cleveland Range, LLC décline toute obligation ou responsabilité concernant les errata, modifications, révisions ou mises à jour.

Les Représentants de Service qualifiés et autorisés de Cleveland Range, LLC sont tenus de se conformer aux mesures de sécurité normalisées de l'industrie, y compris, mais sans s'y limiter, les réglementations de l'OSHA, les procédures de débranchement / verrouillage / étiquetage relatives à tous les services publics, dont l'approvisionnement en vapeur, et les procédures de débranchement / verrouillage / étiquetage relatives aux équipements et/ou appareils fonctionnant au gaz, à l'électricité et à la vapeur.

Au cours de tout entretien d'un appareil Cleveland Range, tous les services publics (gaz, électricité, eau et vapeur) doivent être FERMÉS au niveau de l'appareil et le dispositif de fonctionnement doit être verrouillé suivant les pratiques approuvées de l'OSHA.

Les Représentants de Service qualifiés et autorisés de Cleveland Range, LLC sont tenus d'actualiser en permanence leurs connaissances, compétences, matériel et équipement.

Este documento está destinado para el uso de los Representantes de Servicio calificados y autorizados de Cleveland Range, LLC quienes cuentan con la experiencia y la capacitación así como el buen conocimiento de las medidas de seguridad y de los equipos que mantienen.

Cleveland Range, LLC, declina toda responsabilidad en caso de cualquier fallecimiento, lesiones, daños al equipo o daños a la propiedad resultantes de la utilización, del uso indebido o de la falta de utilización de la información provista en este documento.

Cleveland Range, LLC se ha esforzado en suministrar información precisa en este documento, pero no puede garantizar que este documento esté exento de errores y de omisiones no intencionales.

La información contenida en este documento podría estar sujeta a cambios técnicos o tecnológicos, revisiones o actualizaciones. Cleveland Range, LLC declina toda obligación o responsabilidad con respecto a erratas, modificaciones, revisiones o actualizaciones.

Los Representantes de Servicio calificados y autorizados de Cleveland Range, LLC tienen la obligación de seguir los procedimientos estándar de seguridad de la industria; los cuales incluyen pero no se limitan a los reglamentos de la OSHA (La Administración de la Seguridad y Salud Ocupacionales), los procedimientos de desconexión, cierre y etiquetado relativos a todos los servicios públicos incluyendo el suministro de vapor y los procedimientos de desconexión, cierre y etiquetado para los equipos y/o aparatos que funcionan a base de gas, electricidad o vapor.

Cuando se esté dando servicio o mantenimiento a un aparato de Cleveland Range, todos los servicios públicos (gas, electricidad, agua y vapor) deben estar APAGADOS para el equipo en cuestión y se debe seguir el procedimiento de cierre de operaciones de acuerdo con las prácticas aprobadas por la OSHA.

Los Representantes de Servicio calificados y autorizados de Cleveland Range, LLC tienen la obligación de actualizar constantemente sus conocimientos, destrezas, materiales y equipamiento.

# **FOR YOUR SAFETY / POUR VOTRE SÉCURITÉ / PARA SU SEGURIDAD**

## **FOR YOUR SAFETY**

**Do not store or use gasoline or any other flammable liquids and vapours in the vicinity of this or any other appliance.**

## **POUR VOTRE SÉCURITÉ**

**Ne pas entreposer ou utiliser d'essence ou d'autres liquides ou vapeurs inflammables à proximité de cet appareil ou de tout autre appareil.**

## **PARA SU SEGURIDAD**

**No guarde ni use gasolina o cualesquiera otros líquidos o vapores inflamables en las cercanías de éste o cualquier otro aparato.**

**WARNING: Improper installation, operation, adjustment, alteration, service or maintenance can cause property damage, injury or death. Read the installation and operating instructions thoroughly before installing, operating or servicing this equipment.**

**AVERTISSEMENT : Toute mauvaise pratique en matière d'installation, de fonctionnement, de réglage, de modification, d'entretien ou de maintenance peut causer des dommages matériels, des blessures ou la mort. Lisez la totalité des instructions d'installation et d'utilisation avant d'installer, d'utiliser ou d'entretenir cet équipement.**

**ADVERTENCIA: La indebida instalación, operación, ajuste, modificación, servicio o mantenimiento puede ocasionar daños a la propiedad, lesiones o muerte. Lea detenidamente las instrucciones de instalación y de operación antes de instalar, poner a funcionar o dar servicio a este equipo.**

Do not spray aerosols in the vicinity of this appliance while it is in operation.

This appliance is not to be used by persons with reduced physical, sensory or mental capabilities, or lack of experience and knowledge, unless they have been given supervision or instruction concerning use of the appliance by a person responsible for their safety.

This appliance is not for use by children and they must be supervised not to play with it.

Retain this manual for your reference.

Ne pas pulvériser des aérosols dans le voisinage de cet appareil alors qu'il est en fonctionnement.

Cet appareil ne doit pas être utilisé par des personnes dont les capacités physiques, sensorielles ou mentales sont réduites, ou des personnes dénuées d'expérience ou de connaissance, sauf si elles ont pu bénéficier, par l'intermédiaire d'une personne responsable de leur sécurité, d'une surveillance ou d'instructions préalables concernant l'utilisation de l'appareil.

Cet appareil n'est pas destiné à être utilisé par des enfants et ils doivent être surveillés pour s'assurer qu'ils ne jouent pas avec l'appareil.

Conservez ce manuel pour votre référence.

No pulverice aerosoles en las proximidades de este aparato mientras está en funcionamiento.

Este aparato no debe ser utilizado por personas con capacidades físicas, sensoriales o mentales reducidas, o que no tengan la experiencia y los conocimientos adecuados, a menos que estas personas hayan recibido supervisión e instrucciones en cuanto al uso del aparato por la persona responsable de la seguridad de ellas.

Guarde este manual para su referencia.



## WARNING / AVERTISSEMENT / ADVERTENCIA



Improper installation, operation, adjustment, alteration, service or maintenance can cause property damage, injury or death. Read the installation and operating instructions thoroughly before installing, operating or servicing this equipment. / Toute mauvaise pratique en matière d'installation, de fonctionnement, de réglage, de

modification, d'entretien ou de maintenance peut causer des dommages matériels, des blessures ou la mort. Lisez la totalité des instructions d'installation et d'utilisation avant d'installer, d'utiliser ou d'entretenir cet équipement. / La indebida instalación, operación, ajuste, modificación, servicio o mantenimiento puede ocasionar daños a la propiedad, lesiones o muerte. Lea detenidamente las instrucciones de instalación y de operación antes de instalar, poner a funcionar o dar servicio a este equipo.



Do not lean on or place objects on lip. / Ne vous penchez pas sur ou ne placez pas des objets sur la lèvres. / No se apoye ni coloque objetos en el labio.



Hot product and surfaces. / Produit et surfaces chaudes. / Producto y superficies calientes.

Do not touch. / Ne pas toucher. / No la toque



Stand clear of product discharge path when discharging hot product. / Écartez-vous du chemin de décharge d'un produit chaud. / Permanezca alejado de la ruta de descarga del producto al vaciar producto caliente.



Keep hands away from moving parts and pinch points. / Gardez les mains loin des pièces mobiles et des points de pincement. / Mantenga las manos lejos de piezas móviles y puntos de presión muy localizada.



Inspect unit daily for proper operation. / Inspectez l'unité tous les jours pour son bon fonctionnement. / Inspeccione diariamente el funcionamiento correcto de la unidad.



Pressurized device. / Appareil sous pression. / Dispositivo de presión.

Keep clear of pressure relief discharge. / Restez à l'écart de la soupape de sûreté. / Permanezca alejado de la descarga de presión.



Do not climb, sit or stand on equipment. / Il ne faut pas monter, s'asseoir ni se tenir debout sur l'équipement. / No subirse, ni sentarse ni pararse sobre el equipo.



Surfaces and product may be hot! Wear protective equipment. / Les surfaces et le produit peuvent être chauds! Portez un équipement de protection. / ¡Las superficies y el producto pueden estar calientes! Utilice equipo protector.



Heavy / Lourd / Pesado

Team or mechanical lift. / Équipe ou remontée mécanique. / Equipo o elevador mecánico.



Floor may become slippery from product spillage. / Déversement de produit peut causer de plancher à être glissant. / Derrame de producto puede causar piso a ser resbaladizo.



Unit must be anchored as per manual. / Unité doit être ancrée selon les directives du manuel. / Unidad debe estar fijado según el manual.



Do not fill kettle above recommended level marked on outside of kettle. / Ne remplissez pas la chaudière en excès du niveau recommandé marqué sur la chaudière. / No llene la marmita arriba del nivel recomendado marcado fuera de la marmita.

## SERVICING / ENTRETIEN / SERVICIO



Have a qualified service technician maintain your equipment. / Demandez à un technicien en entretien et en réparation qualifié d'effectuer l'entretien de votre équipement. / Haga que un técnico de servicio calificado mantenga su equipo



Ensure kettle is at room temperature and pressure gauge is showing zero or less prior to removing any fittings. / Assurez-vous que la chaudière est à température ambiante et que le manomètre est à zéro ou moins avant de retirer des accessoires. / Asegúrese de que la marmita esté a temperatura ambiente y el manómetro esté mostrando cero o menos antes de retirar cualquier accesorio.



Remove electrical power prior to servicing. / Coupez l'alimentation électrique avant l'entretien. / Desconecte la energía eléctrica antes de darle servicio.

Risk of electric shock. / Risque de choc électrique. / Riesgo de choque eléctrico.

# INSTALLATION

## GENERAL

Installation of the unit must be accomplished by qualified installation personnel working to all applicable local and national codes. Improper installation of product could cause injury or damage.

This unit is built to comply with applicable standards for manufacturers. Included among those approval agencies are: UL, NSF, ASME/Ntl.Bd., CSA, ETL, CE, and others. Many local codes exist, and it is the responsibility of the owner/installer to comply with these codes.

## RECEIVING INSPECTION

Before uncrating, visually inspect the unit for evidence of damage during shipping.

If damage is noticed, do not unpack the unit, follow shipping damage instructions.

## SHIPPING DAMAGE INSTRUCTIONS

If shipping damage to the unit is discovered or suspected, observe the following guidelines in preparing a shipping damage claim.

1. Write down a description of the damage or the reason for suspecting damage as soon as it is discovered. This will help in filling out the claim forms later. If possible, take a polaroid picture.
2. As soon as damage is discovered or suspected, notify the carrier that delivered the shipment.
3. Arrange for the carrier's representative to examine the damage.
4. Fill out all carrier claims forms and have the examining carrier sign and date each form.

## APPROXIMATE WEIGHTS

Model #	Unit	Unit with shipping box
KDM-25-T	330 lbs.	370 lbs.
KDM-40-T	385 lbs.	425 lbs.
KDM-60-T	430 lbs.	470 lbs.



## UNCRATING

### Caution:

Straps under tension and will snap when cut.

Carton may contain staples and Skid contains Nails.

Use proper safety equipment and precautions.

Unit is heavy use adequate help or lifting equipment as needed.

1. Carefully cut any straps from container.
2. Lift off carton.
3. Inspect for hidden damage. If found refer to "SHIPPING DAMAGE INSTRUCTIONS".
4. Cut strap holding unit.
5. Remove manual from kettle pot. Write down the model # and serial# of the unit onto the front of this manual.
6. Lift kettle off skid and move kettle to its installation location.
7. Discard packaging material according to local and or state requirements.

## VENTILATION

Operation of these units can produce significant levels of steam and condensate, it is recommended they be installed under a ventilation hood in a room which has provisions for adequate make up air. Further information can be obtained by referring to the U.S.A. National Fire Protection Associations NFPA96 regulations. These standards have also been adopted by the National Building Code in Canada.

## POSITIONING

Position the kettle in its permanent location, and level the kettle by turning the adjustable flanged feet. Once positioned and levelled, permanently secure the kettle's flanged feet to the floor using lag bolts and floor anchors (to be supplied by the installer).

## SERVICE CONNECTIONS

Install service connections as required. Locations and other data are shown on the Specification Sheet.

## FOR POWER TILT UNITS ONLY

**NOTE:** Ensure the electrical supply matches the kettle's requirements as stated on the rating label.

This kettle is built to comply with CE standards. Many local codes exist, and it is the responsibility of the owner and installer to comply with these codes.

## STEAM

All steam plumbing to and from the kettle and steam boiler should be thoroughly cleaned and inspected for dirt and debris before final connection to the kettle are made.

Check the rating plate for the maximum steam pressure that your kettle is rated for. If the steam supply pressure exceeds the rated pressure, a pressure reducing valve is required. The steam inlet is at the right side of the kettle, as seen from the front.

## STEAM REQUIREMENTS

Kettle Cap. U.S. Gal.	Kettle Dia.	25 psi Steam Lbs./Hr.
25	21"	70
40	26"	100
60	29.5"	150

- ❑ Steam requirements are maximum per hour.
- ❑ If more than one unit is on the same line then add the steam usage for each one to reach a total.

## RECOMMENDED PIPING SCHEMATICS

(all service connections shown supplied by others)

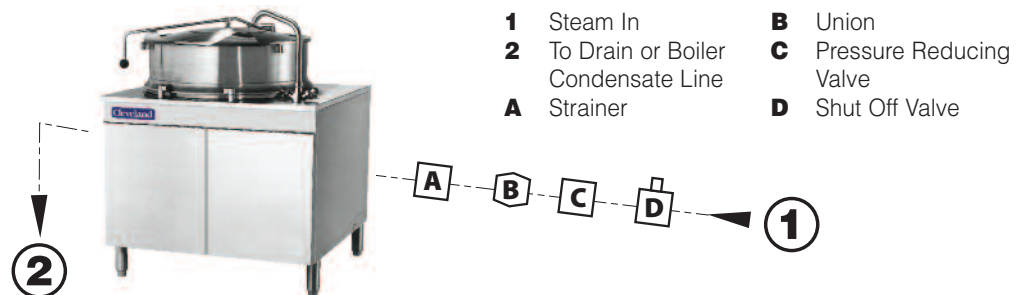

## CONDENSATE

A steam condensate trap must be plumbed to a drain, using minimum 1/2" NPT plumbing. The condensate line is limited to a maximum rise of 10 feet in order for the steam pressure to adequately force the condensate through the plumbing. Any higher rise requires a pump.

If the steam boiler to which this kettle is installed has a condensate return (closed loop system), a 1/2" steam strainer, a 1/2" steam trap, and a 1/2" check valve must be installed on the output (condensate) side of the kettle.

## POTABLE WATER

The water faucet (optional) with swing spout, requires 1/2 inch O.D. copper tube plumbing for hot or cold water supplies to the faucet (SPK - cold water connection only, DPK - hot and cold water connection).

## INSTALLATION CHECK

1. Partially fill the kettle with water.
2. Slowly turn the steam supply valve's knob to the open position.
3. Release the safety valve, ensuring that the steam escapes freely. Stay clear of steam exhaust when releasing the safety valve.
4. Observe that the water in the kettle comes to a boil.
5. Close the steam supply valve.
6. Drain off the water in the kettle.

## CLEANING

After installation the kettle must be thoroughly cleaned

# OPERATING INSTRUCTIONS



## WARNING

If for any reason this unit is not functioning correctly  
**DO NOT OPERATE.**

Contact your authorized service agent.



## # DESCRIPTION

1. Steam Inlet Valve  
Opens and closes the steam supply to the kettle.
2. Power Tilt Switch  
Used for tilting the kettle up or down.
3. Drain Cock  
Used to drain condensate from the bottom of tilting units only.
4. Tangent Draw-Off Valve  
Used for draining product or wash water from kettle.
5. Pressure Relief Valve (not shown)  
In the unlikely event that there is an excess steam build-up in the jacket, this valve automatically opens to relieve this pressure.

## OPERATION

1. Ensure that there is an adequate steam supply to the kettle.
2. For optimum performance on free-standing floor model tilting kettles, open drain cock to drain condensate from the kettle's jacket, then close drain cock before applying steam to a cold kettle.
3. If the kettle is equipped with a tangent draw-off valve, ensure that it is closed before filling the kettle. To keep solid food particles out of the draw-off valve, place either a solid or a perforated strainer in the bottom of the kettle.

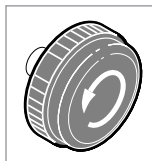

4. Turn the steam control valve to the open position by turning the knob counter-clockwise, then allow the kettle to preheat.

**NOTE:** When cooking egg and milk products, the kettle should NOT be preheated, as products of this nature adhere to hot cooking surfaces. These types of foods should be placed in the kettle before heating is begun.

5. Fill kettle with product to desired level.

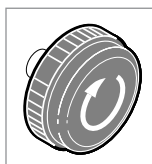

6. When the product has reached the desired temperature, regulate the heat, as required, by turning the steam control valve clockwise for less steam, and therefore, a lower temperature.

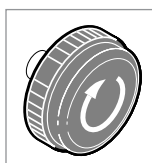

7. When cooking is complete, close the steam control valve by turning the knob clockwise.

8. Power tilt kettles are provided with a rocker-type center-off switch for raising and lowering the kettle. To raise the kettle, press the top of the switch. To lower the kettle, press the bottom of the switch. Release the switch, allowing it to return to the center "off" position when the desired degree of tilt has been reached. Limit switches are provided that automatically stop the tilt motion at the maximum limit of movement in either direction.

To raise and lower a manual tilt kettle, turn the handwheel counter-clockwise to lower and clockwise to raise.

## FOR KETTLE/STEAMER COMBINATIONS:

If the boiler in a steamer is supplying steam to a kettle, always heat the kettle first. After the kettle contents are heated, and the boiler's steam pressure returns to normal, the steamer may be used. Pressure steamer compartments should be sequentially started, and preheated before cooking.

# CLEANING INSTRUCTIONS



## CARE AND CLEANING

Cooking equipment must be cleaned regularly to maintain its fast, efficient cooking performance and to ensure its continued safe, reliable operation. The best time to clean is shortly after each use (allow unit to cool to a safe temperature).

## WARNINGS



Chloride Cleaners

Do not use detergents or cleansers that are chloride based or contain quaternary salt.



Wire Brush & Scrapers

Do not use a metal bristle brush or scraper.



Steel Pads

Steel wool should never be used for cleaning the stainless steel.

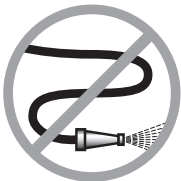

High Pressure Spray Hose

Unit should never be cleaned with a high pressure spray hose.



Stagnant Water

Do not leave water sitting in unit when not in use.

## CLEANING INSTRUCTIONS

1. Turn unit off.
2. Remove drain screen (if applicable). Thoroughly wash and rinse the screen either in a sink or a dishwasher.
3. Prepare a warm water and mild detergent solution in the unit.
4. Remove food soil using a nylon brush.
5. Loosen food which is stuck by allowing it to soak at a low temperature setting.
6. Drain unit.
7. Rinse interior thoroughly.
8. If the unit is equipped with a **Tangent Draw-Off Valve**, clean as follows:
  - a) Disassemble the draw-off valve first by turning the valve knob counter-clockwise, then turning the large hex nut counter-clockwise until the valve stem is free of the valve body.
  - b) In a sink, wash and rinse the inside of the valve body using a nylon brush.
  - c) Use a nylon brush to clean tangent draw-off tube.
  - d) Rinse with fresh water.
  - e) Reassemble the draw-off valve by reversing the procedure for disassembly. The valve's hex nut should be hand tight only.
9. Using mild soapy water and a damp sponge, wash the exterior, rinse, and dry.

## NOTES

- ⇒ For more difficult cleaning applications one of the following can be used: alcohol, baking soda, vinegar, or a solution of ammonia in water.
- ⇒ Leave the cover off when the kettle is not in use.
- ⇒ For more detailed instructions refer to Stainless Steel Equipment Care and Cleaning ([www.nafem.org/resources/stainlesssteelfinal.doc](http://www.nafem.org/resources/stainlesssteelfinal.doc)) on Nafem's website ([www.nafem.org](http://www.nafem.org)).

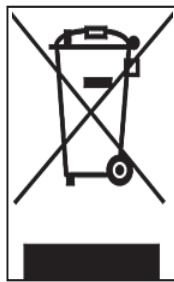

## DISPOSAL INSTRUCTIONS

This unit is recyclable. Do not dispose in landfill.

The majority of the unit is composed of stainless steel. Other alloys and electrical components make up a small percentage of the total. Follow Federal, state and local regulations for disposal.

# **PREVENTATIVE MAINTENANCE**

**FOR MAINTENANCE AND REPAIRS CONTACT YOUR AUTHORIZED  
MANITOWOC SERVICE AGENCY AND HAVE A QUALIFIED SERVICE  
TECHNICIAN MAINTAIN YOUR EQUIPMENT.**



## **WARNING**

If for any reason this unit is not functioning correctly **DO NOT OPERATE.**  
Contact your authorized service agent.

Refer to maintenance procedures and parts list manual  
for detailed maintenance and testing instructions.



## **DAILY PRE-STARTUP INSPECTION**

1. Steam valve opens and closes.
2. Product discharge valve is functioning correctly.
3. Cover opens and closes correctly and is not loose or damaged.

---

## **SIX MONTH SERVICE INSPECTION**

- 1 Perform daily startup inspection.
2. Test pressure relief valve.
- 3 Hand tilting - Check handwheel for tightness. If loose tighten Allen screw.  
Power tilting - Check that kettle tilts smoothly. Grease as described in Lubrication Procedure.
4. Inspect for steam leaks inside and outside console.
5. Unit is bolted to the floor correctly.
6. Clean strainers.

# MAINTENANCE

**ALL SERVICE MUST BE PERFORMED BY A QUALIFIED SERVICE TECHNICIAN.**

This kettle requires very little preventative maintenance other than daily cleaning.  
The pressure relief valve must be tested twice a year.



## WARNING

If for any reason this unit is not functioning correctly **DO NOT OPERATE.**  
Contact your authorized service agent.

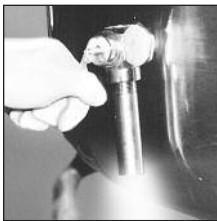

## PRESSURE RELIEF VALVE TESTING PROCEDURE

The pressure relief valve must be checked at least twice a year as part of the normal maintenance performed.

1. With the kettle empty, fully open the steam valve and allow the kettle to preheat.
  2. Stand to the side of the pressure relief valve discharge tube and pull valve open for a maximum of one second. Repeat test three to four times. Each time the mechanism should move freely and be accompanied by a rapid escape of steam.
- ⇒ If valve appears to be sticking replace pressure relief valve.
- ⇒ If foreign material is discharged then drain kettle and replace pressure relief valve.

## STEAM TRAP

To remove condensate that forms inside the steam jacket, each kettle should be equipped with a steam trap in the line of the kettle outlet to the drain. A good steam trap at startup releases air and wet steam into the drain line for a few minutes, then holds the steam in the jacket. During cooking, the trap periodically releases accumulated condensate. If the kettle's cooking performance becomes inadequate after long use, replacement of the steam trap with a new one may restore kettle operation to peak efficiency.

## DRAW-OFF VALVE

To correct a leak at the draw-off valve, the source of the leak must first be determined. Leaks from around the valve stem are corrected by simply replacing the "O" ring. Faulty seating of the valve stem disc against the valve body may cause dripping from the valve even when the valve is tightly closed. This can often be corrected by cleaning any residue from the disc and seat.

## HINGE ADJUSTMENT INSTRUCTIONS

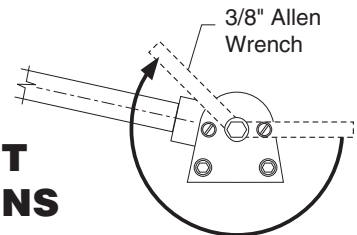

1. Insert 3/8" Allen wrench.
2. Turn clockwise to relieve tension on spring.
3. While tension is released remove one of the two slotted screws.
4. To prevent Allen wrench from springing back abruptly while the second slotted screw is removed, insert a pin (approximately 1/8") in the hole where the first slotted screw was removed from.
5. Remove second slotted screw.
6. While holding Allen wrench remove pin.
7. Turn Allen wrench clockwise to tighten or counter-clockwise to loosen tension to produce desired effect.
8. Re-insert pin in one of the two holes.
9. Tighten one slotted screw in the other hole (it may be necessary to turn Allen wrench slightly to align holes).
10. Remove pin and repeat step number 9. for other slotted screw.

## TROUBLESHOOTING GUIDE

This section contains information intended for use by Authorized Service Personnel only.

### STEAM REQUIREMENTS

Kettle Cap. U.S. Gal.	Kettle Dia.	25 psi Steam Lbs./Hr.
25	21"	70
40	26"	100
60	29.5"	150

- Steam requirements are maximum per hour.
- If more than one unit is on the same line then add the steam usage for each one to reach a total.

**A/ PROBLEM:** Kettle heats too slowly or does not come to a boil.

- | <b>Probable Cause</b>                    | <b>Remedy</b>  |
|--|--|
| 1. Inadequate steam flow.                | Check for correct steam.<br><br>If kettle is connected to a steamer and powered by a generator the units should be operated sequentially (kettle boiling first, then start steamer). |
| 2. Steam trap not operating properly.    | The trap should open periodically to dump condensate, then close.<br>If it does not open or close it should be cleaned or replaced.  |
| 3. Food batches are not always the same. | When checking make certain that the original state (ie. fresh or frozen) and quantity of food product is the same.   |

**B/ PROBLEM:** Kettle fails to tilt. (NOTE: A thermal overload in jack motor does not allow constant consecutive tilting).

- | <b>Probable Cause</b>           | <b>Remedy</b>  |
|---------------------------------|--|
| 1. Defective tilt switch.       | Shut off power to unit and remove entire control housing cover box to expose tilt switch. Test switch for proper continuity. Replace if necessary.   |
| 2. Defective jack or capacitor. | Remove cover from upper junction box. This will access the wire connections to the power jack. Measure the resistance across each of the three wires. It is not necessary to disconnect the wiring if proper contact can be made between the probe and connectors. Their resistance should read (approximately):<br><br>14 ohms between the black and white,<br>29 ohms between the black and red, and<br>14 ohms between the red and white. |

**C/ PROBLEM:** Kettle fails to lift or tilt at a normal speed.

- | <b>Probable Cause</b>           | <b>Remedy</b>   |
|---------------------------------|---|
| 1. Defective jack or capacitor. | Shut off power to unit and remove entire control housing cover box to expose tilt switch. Test switch for proper continuity. Replace if necessary.. |

**D/ PROBLEM:** The trunnion housing leaks steam.

- | <b>Probable Cause</b>           | <b>Remedy</b>     |
|---------------------------------|-------------------|
| 1. Trunnion "O" rings are worn. | Replace "O" rings |

**E/ PROBLEM:** The steam trap makes a banging noise when steam applied to cold kettle.

- | <b>Probable Cause</b>                      | <b>Remedy</b>  |
|--|--|
| 1. Kettle condensate has not been drained. | On all tilting models the condensate should be drained when kettle is cold using the drain cock valve on the bottom of the kettle. |

## WIRING DIAGRAM

Power Tilt Units Only  
115 Volts, 1PH, 60HZ

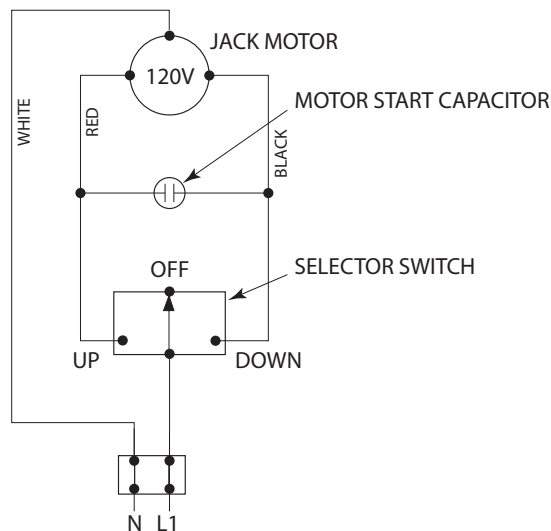

# SERVICE PARTS

## WARRANTY

Our Company supports a worldwide network of Maintenance and Repair Centers. Contact your nearest Maintenance and Repair Centre for replacement parts, service, or information regarding the proper maintenance and repair of your cooking equipment. In order to preserve the various agency safety certification (UL, NSF, ASME/Ntl. Bd., etc.), only factory-supplied replacement parts should be used. The use of other than factory supplied replacement parts will void warranty.

## KETTLE BODY

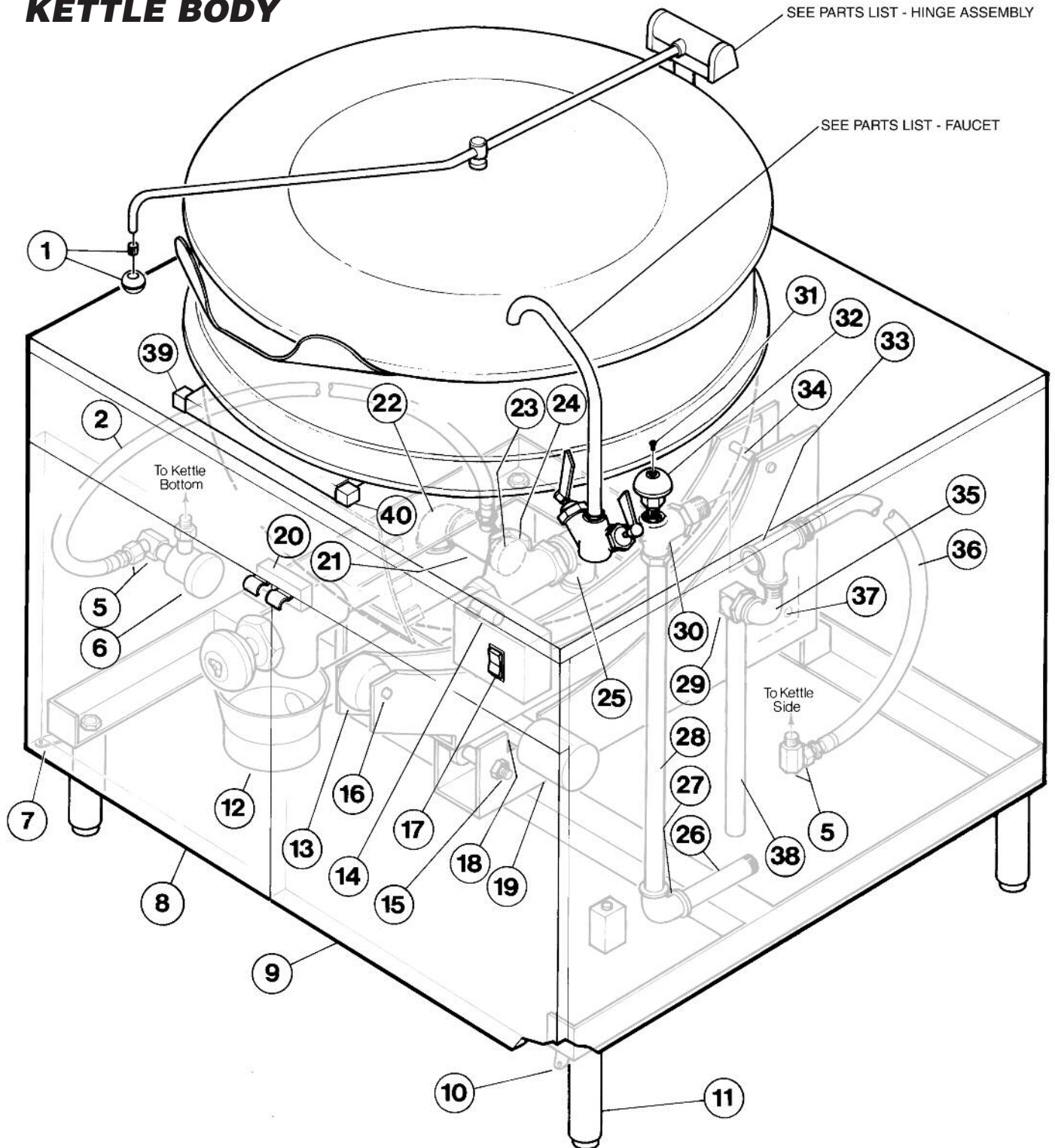

# **PARTS LIST - KETTLE BODY**

<b>ITEM NO.</b>	<b>PART NO.</b>	<b>DESCRIPTION</b>	<b>QTY.</b>
1.	KE50151-1	Knob, ball type . . . . .	1
2.	T40294	Hose, Condensate (KDM-25) . . . . .	1
	T40295	Hose, Condensate (KDM-40, KDM-60) . . . . .	1
5.	F105028	Swivel Elbow, 1/2" . . . . .	2
6.	KE51248-1	Steam Trap, 1/2" . . . . .	1
7.	KE02211-1	Left Door Hinge Bracket Assy. (used after June 02, 2000) . . . . .	1
	KE00652	Left Door Hinge Bracket Assy. (used prior to June 02, 2000) . . . . .	1
8.	KE02210-1	Left Door Assy. (KDM-25) . . . . .	1
	KE02210-3	Left Door Assy. (KDM-40, KDM-60) . . . . .	1
9.	KE02210-2	Right Door Assy. (KDM-25) . . . . .	1
	KE02210-4	Right Door Assy.(KDM-40,KDM-60) . . . . .	1
10.	KE02211-2	Right Door Hinge Bracket Assy. (used after June 02, 2000) . . . . .	1
	KE00651	Right Door Hinge Bracket Assy. (used prior to June 02, 2000) . . . . .	1
11.	KE51340	Leg . . . . .	4
12.	KE00665	Swing Funnel Assy. (KDM-25) . . . . .	1
	KE00666	Swing Funnel Assy. (KDM-40) . . . . .	1
	KE00667	Swing Funnel Assy. (KDM-60) . . . . .	1
13.	KE51365	Roller Wheel, 3" Dia. . . . .	1
14.	KE51683	Capacitor, 36-43 mF . . . . .	1
15.	FA15010	Shoulder Bolt, 1/2" X 3 1/4", 3/8-16 . . . . .	1
16.	FA15009	Shoulder Bolt, 3/4" X 2 1/2", 5/8-11 . . . . .	1
17.	SK50680	Tilt Switch . . . . .	1
18.	KE51688	Power Jack, c/w Motor . . . . .	1
19.	SE50025	Motor, Power Jack . . . . .	1
20.	KE51366-1	Magnetic Door Latch (used after October 11, 2001) . . . . .	1
	KE51366	Magnetic Door Latch (used prior to October 11, 2001) . . . . .	1
21.	KE00648	Drain Pipe Manifold . . . . .	1
22.	FI00040-2	Straight Elbow, 90, 1 1/2" . . . . .	1
23.	F100191	End Cap, 1 1/2" . . . . .	1
24.	KE51367	Check Valve, 1 1/4" . . . . .	1
25.	FI00136	Street Elbow, 90, 1 1/4" . . . . .	1
26.	KE51372	Steam In Pipe 1/2" X 7 1/2" LG . . . . .	1
27.	FI00040-1	Straight Elbow, 90, 1/2" . . . . .	1
28.	KE51371	Steam In Pipe, 1/2" X 18 1/2" LG. . . . .	1
29.	KE54941-7	Safety Valve, 25 PSI, 1/2", ASME . . . . .	1
	KE54941-32	Safety Valve, 25 PSI, 1/2", CE . . . . .	1
30.	KE02055-1	Steam Inlet Valve Assy. 1/2" Brass . . . . .	1
31.	FA11091	Screw, Valve Knob, 8/32 X 3/8" SS . . . . .	1
32.	KE50442	Knob, Steam Inlet Valve . . . . .	1
33.	FI00169	Tee, 1/2" . . . . .	1
34.	FA15008	Shoulder Bolt 5/8" X 3 1/4", 1/2-13 . . . . .	1
35.	FI00142	Street Elbow, 1/2" . . . . .	1
36.	T40292	Hose, Steam (KDM-25) . . . . .	1
	T40293	Hose, Steam (KDM-40, KDM-60) . . . . .	1
37.	KE51364	Jack Mounting Pin . . . . .	1
38.	KE51087	Blow Down Pipe, 1/2" X 17"LG. . . . .	1
39.	KE51433-1	Bracket Block, Left Hand . . . . .	1
40.	KE51433-2	Bracket Block, Right Hand . . . . .	1

# TANGENT DRAW-OFF VALVES

## 1.5" & 3" TANGENT DRAW-OFF VALVE

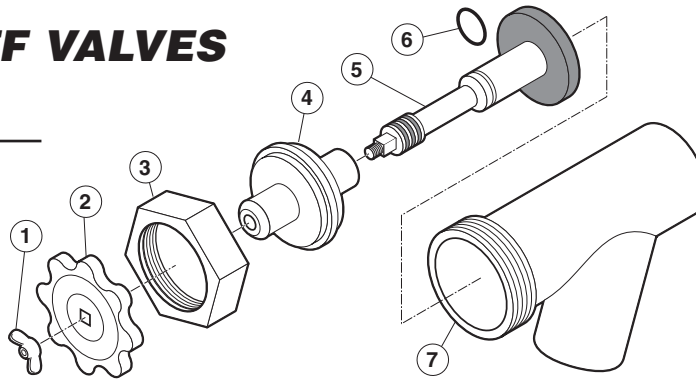

ITEM NO.	PART NO.	DESCRIPTION	QTY.
1. - 7.	KE50219	1.5" DRAW-OFF ASSEMBLY	1
	KE50973	3" DRAW-OFF ASSEMBLY	1
1.	SE50019	WING NUT, TD-1.5	1
	FA21501-1	ACCORN NUT, TD-3	1
	FA11511-1	SCREW (CORRECTIONAL PACKAGE)	1
	FA30505-1	WASHER (CORRECTIONAL PACKAGE)	1
2.	SE50017	KNOB, TD-1.5	1
	SE50018	KNOB, TD-3	1
3.	FI05180-3	HEX NUT, TD-1.5	1
	FI05180-2	HEX NUT, TD-3	1
4.	SE50011	RETAINER, TD-1.5	1
	SE50013	RETAINER, TD-3	1
5.	SE50008	PISTON, TD-1.5	1
	SE50010-1	PISTON, TD-3	1
	KE53290-4	PISTON, TD-3, MODIFIED (CORRECTIONAL PACKAGE)	1
6.	FA05002-24	"O" RING, TD-1.5	1
	FA05002-38	"O" RING, TD-3	1
7.	SE50005	VALVE BODY, TD-1.5	1
	KE50973	VALVE BODY, TD-3	1

## 2" TANGENT DRAW-OFF VALVE

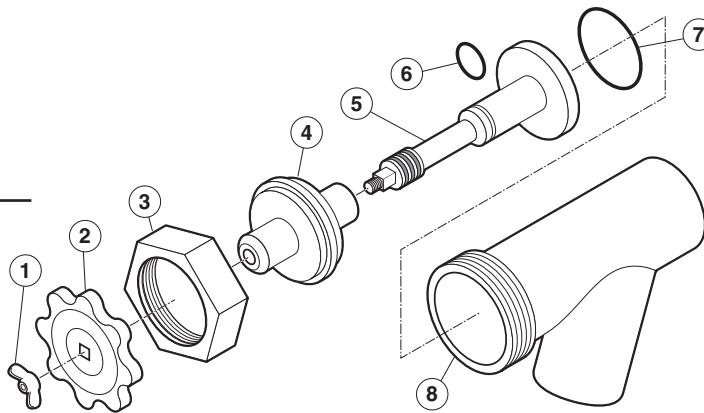

ITEM NO.	PART NO.	DESCRIPTION	QTY.
1. - 7.	KE50972-B	2" DRAW-OFF ASSEMBLY	1
1.	FA95049	WING NUT, TD-2	1
	FA511511-5	SCREW, TD-2 (CORRECTIONAL PACKAGE)	1
2.	KE52755	KNOB, TD-2	1
3.	FI05180-1	HEX NUT, TD-2	1
4.	KE52753	RETAINER, TD-2	1
5.	KE52752-1	PISTON, TD-2	1
	KE53290-3	PISTON, TD-2 (CORRECTIONAL PACKAGE)	1
6.	FA05002-24	"O" RING, BUNA-N (A-111), TD-2	1
7.	FA05002-55	"O" RING, VITON (AS568A-322), TD-2	1
8.	KE52751	VALVE BODY, TD-2	1

# FAUCETS

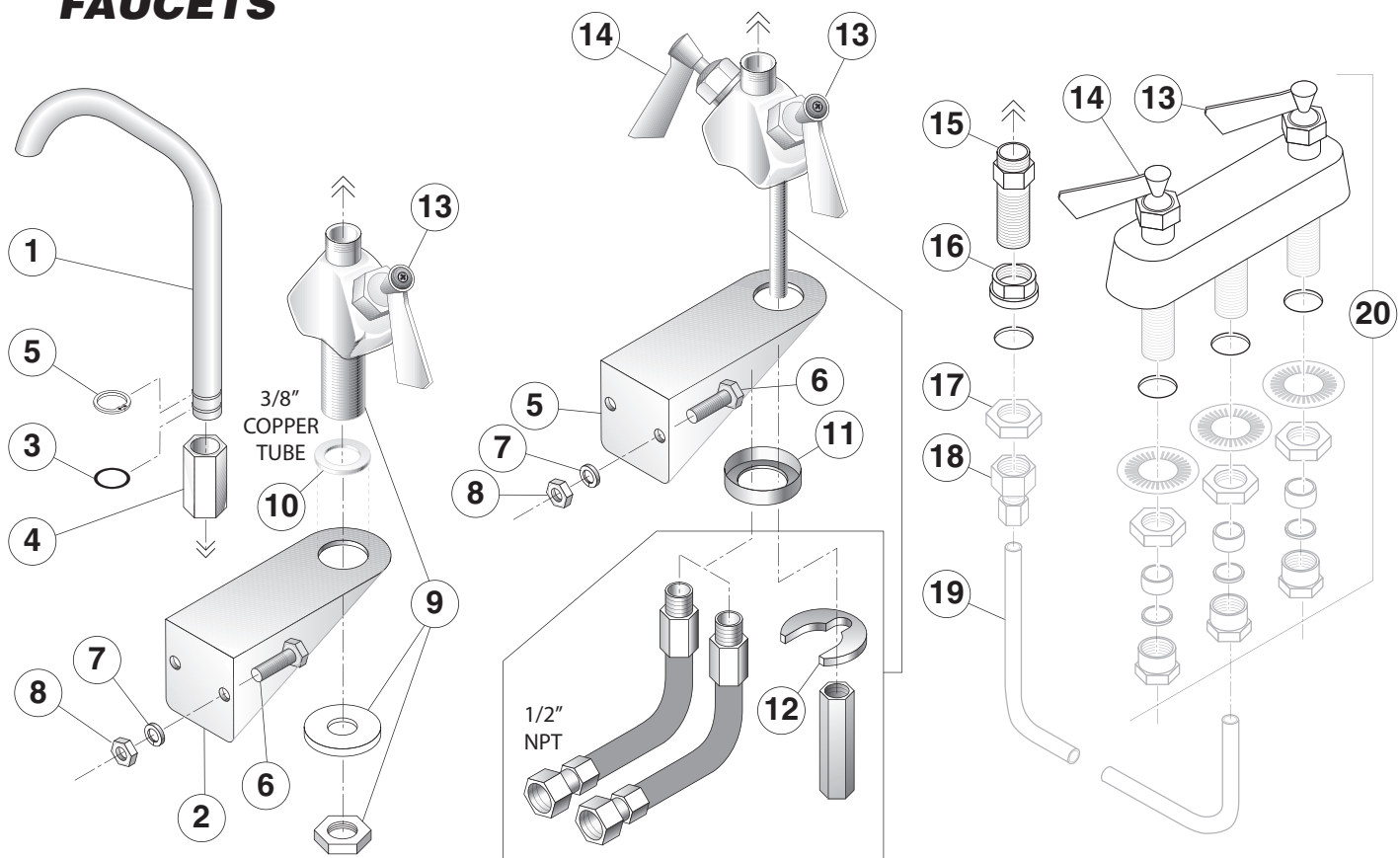

## Common Parts

ITEM #	PART #	DESCRIPTION	QTY.
	<b>SPK</b> _____	<b>SINGLE PANTRY FAUCET KIT</b> , (includes items 1-10) see page 2 for ordering information	
	<b>DPK</b> _____	<b>DOUBLE PANTRY FAUCET</b> , (includes items 1-8 & 11) see page 2 for ordering information	
1.	KE50825- _____	<b>SPOUT</b> , see page 2 for ordering information	
2.	_____	<b>FAUCET MOUNTING BRACKET</b> , see page 2 for ordering information	1
3.	FA05002-19	"O" RING	1
4.	KE51736	LONG FAUCET NUT	1
5.	FA95007-10	RETAINING RING	1
6.	FA11258	HEX CAP SCREW	2
7.	FA31029	LOCK WASHER	2
8.	FA21008	HEX NUT	2
9.	KE51401	SINGLE PANTRY BODY (c/w item 13)	1
10.	KE50335	ADAPTER WASHER	1
11.	KE51403	DOUBLE PANTRY BODY (c/w item 13 & 14)	1
12.	SE50447	REPLACEMENT HORSESHOE WASHER	1
13.	SE50021	REPLACEMENT STEM ASSEMBLY, COLD WATER	1
14.	SE50020	REPLACEMENT STEM ASSEMBLY, HOT WATER	1
15.	SD50097	FLANGED NUT, 3/4" NPT, CHROME PLATED	1
16.	KE51585	FAUCET SPOUT FITTING	1
17.	SD50098	LOCKNUT, 3/4" NPT	1
18.	FI00266	COUPLING, 1/2" NPT	1
19.	SD50100	COPPER TUBE	1
20.	KE51899	REMOTE VALVE (c/w item 13 & 14)	1

# FAUCETS

## Models

	<b>FAUCET KIT</b>	<b>BRACKET</b>	<b>SPOUT</b>
KDT12/20 ON SD TABLE	SPK1 DPK1		KE50825-1
KDL60/80/100T KEL40/60/80/100T KET20 KGT,MKET, KDP60-100/T	SPK2 DPK2	KE54159 KE02071-1 (CP)	KE50825-2
KDL25/40T KEL25T,KDP25/40T	SPK3 DPK3	KE54159	KE50825-3
KDM60/T	SPK-KDM60 DPK-KDM60		KE50825-2
KDM25/40/T	SPK6 DPK6		KE50825-6
KDL40/60/80TSH KEL40/60TSH	SPK7 DPK7	KE54159	KE50825-7
KDT6 ON SD OR ST	SPK8 DPK8		KE50825-8
TKET, KET3/6/12	SPK9 DPK9	KE54159	KE50825-9
KDL125/150T KGL40/60/80T KGL40TSH	SPK10 DPK10	KE54159	KE50825-10
HAMKGL60/80/100T	SPK11 DPK11	KE54159	KE50825-11
KGL25T, T1	SPK13 DPK13	SK00395-1 KE02071-2 (CP)	KE50825-7
TR	SPK14 DPK14	SK2382300 SK2382400 (SPACER)	KE50825-6
SET10	DPK15 SPK15	SK2308800	KE50825-6
SET15	SPK16 DPK16	SK2302200	KE50825-6
HAMKGL60/80/100	DPK17 SKP17		KE50825-12
ALL STATIONARY KETTLES	DPK5 SPK5		KE50825-5

# HINGE ASSEMBLY

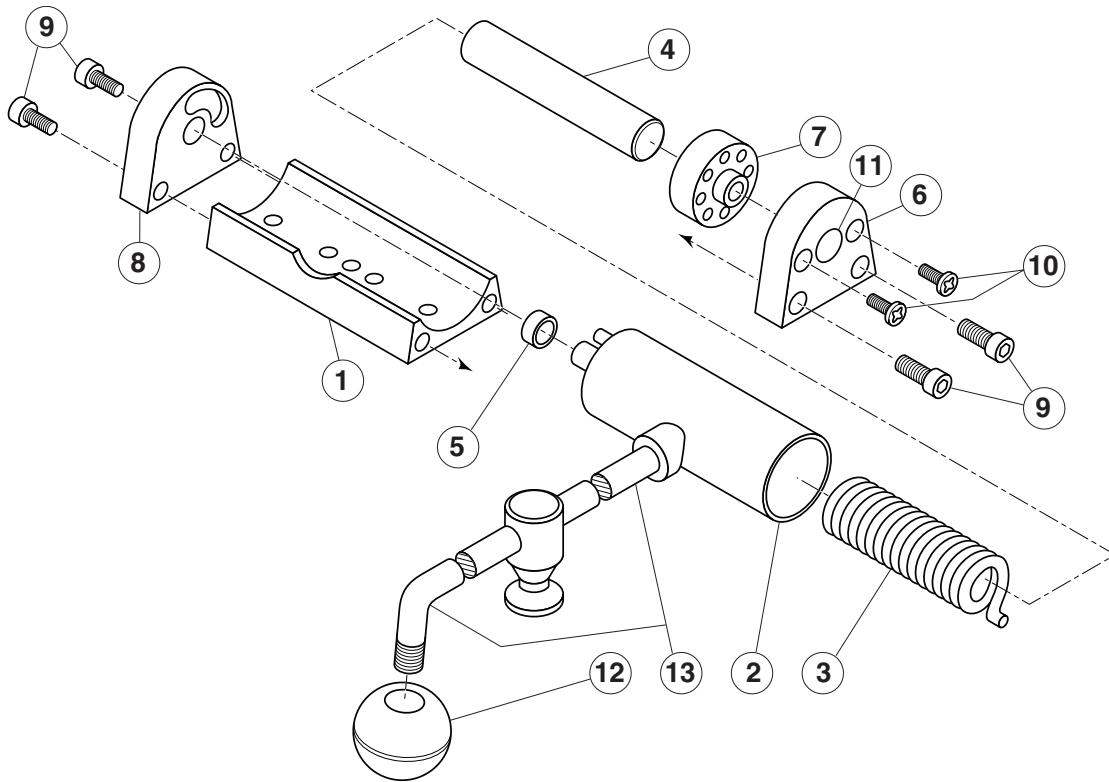

ITEM	PART #	DESCRIPTION	QTY	QTY	QTY	QTY
-	KE00597-6	HINGE ASSY; 25 GALLONS (100 DEG. OPENING, LIGHT SPRING)				▼
-	KE00597-4	HINGE ASSY; KGL-40TSH, HA-MKGL, KDM60T/CT (100 DEG. OPENING, HEAVY SPRING)			▼	
-	KE00597-2	HINGE ASS'Y; 60-100 GALLONS, 30-60F (HEAVY SPRING)		▼		
-	KE00597-1	HINGE ASS'Y; 30-40 GALLONS, 20F, KDM25-40T/CT (LIGHT SPRING)	▼			
1	KE50822	HINGE BASE; CHS	1	1	1	1
2	KE51217	HINGE CYLINDER	1	1	1	1
3	KE50121-1	HINGE SPRING; HEAVY (0.187DIA/12 COILS)	-	1	1	-
	KE50121-2	HINGE SPRING; LIGHT (0.162DIA/16 COILS)	1	-	-	1
4	KE50823-1	HINGE PIN; LIGHT SPRING	1	-	-	1
	KE50823-2	HINGE PIN MODIFD; HEAVY SPRING	-	1	1	-
5	KE50824	HINGE BEARING; MODIFIED	1	1	1	1
6	KE50819-1	HINGE END PIECE; LHS	1	1	-	-
	KE50819-2	HINGE END PIECE; LHS MODIFIED (TO 100 DEGREE)	-	-	1	1
7	KE50820	HINGE INSERT; CHS	1	1	1	1
8	KE50819	HINGE END PIECE; RHS	1	1	1	1
9	FA11284	SCREW; 1/4-20 X 1/2" HEX SOCKET	4	4	4	4
10.	FA11507	Cutting Screw,	2	2	2	2
11.	KE54907-10	Plug Button	1	1	1	1
12.	KE50151-2	Knob	1	1	1	1
13.		Cover Handle (specify model)	1	1	1	1

Every new piece of Welbilt Foodservice equipment comes with KitchenCare® and you choose the level of service that meets your operational needs from one restaurant to multiple locations

**StarCare** – Warranty & lifetime service, certified OEM parts, global parts inventory, performance audited

**ExtraCare** — CareCode, 24/7 Support, online/mobile product information

**LifeCare** – Install & equipment orientation, planned maintenance, KitchenConnect™, MenuConnect®

**Talk with KitchenCare®** • 1-844-724-CARE • [www.mtwkitchencare.com](http://www.mtwkitchencare.com)



To learn how Welbilt Foodservice and its leading brands can equip you, visit our global web site at [www.welbilt.com](http://www.welbilt.com), then discover the regional or local resources available to you.