



Operators Manual

Installation, Operation & Service

Floor Model Direct Steam Kettles

MODELS:

KDL, KDL-T, KDL-SH, KDL-TSH,
KDP, KDP-T



Enodis

1333 East 179th St., Cleveland, Ohio, U.S.A. 44110

Phone: (216) 481-4900 Fax: (216) 481-3782
Visit our web site at www.clevelandrange.com

For your safety

DANGER

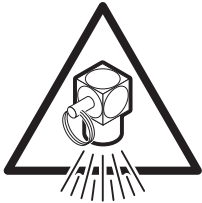

Keep clear of pressure relief discharge.



Keep hands away from moving parts and pinch points.

IMPORTANT



Inspect unit daily for proper operation.

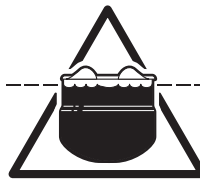

Do not fill kettle above recommended level marked on outside of kettle.

CAUTION



Surfaces may be extremely hot! Use protective equipment.



Wear protective equipment when discharging hot product.



Do not lean on or place objects on kettle lip.

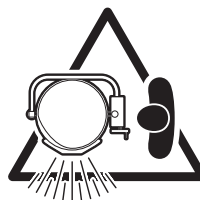

Stand clear of product discharge path when discharging hot product.

SERVICING

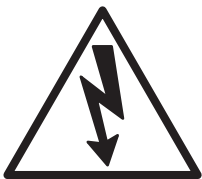

Shut off power at main fuse disconnect prior to servicing.



Ensure kettle is at room temperature and pressure gauge is showing zero or less prior to removing any fittings.

GAS APPLIANCES

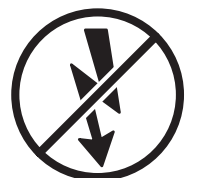

Do not attempt to operate this appliance during a power failure.



Keep appliance and area free and clear of combustibles.

INSTALLATION

GENERAL

Installation of the unit must be accomplished by qualified installation personnel working to all applicable local and national codes. Improper installation of product could cause injury or damage.

This unit is built to comply with applicable standards for manufacturers. Included among those approval agencies are: UL, NSF, ASME/Ntl.Bd., CSA, ETL, CE, and others. Many local codes exist, and it is the responsibility of the owner/installer to comply with these codes.

INSPECTION

Before uncrating, visually inspect the unit for evidence of damage during shipping. If damage is noticed, do not unpack the unit, follow shipping damage instructions.

SHIPPING DAMAGE INSTRUCTIONS

If shipping damage to the unit is discovered or suspected, observe the following guidelines in preparing a shipping damage claim.

1. Write down a description of the damage or the reason for suspecting damage as soon as it is discovered. This will help in filling out the claim forms later. If possible, take a polaroid picture.
2. As soon as damage is discovered or suspected, notify the carrier that delivered the shipment.
3. Arrange for the carrier's representative to examine the damage.
4. Fill out all carrier claims forms and have the examining carrier sign and date each form.

INSTALLATION

The first installation step is to refer to the Specification Sheet for detailed clearance requirements, suggested drain locations and bolting requirements. Next, carefully cut open and remove the shipping carton. Remove all supports and fasteners holding unit to the skid.

KDL SERIES

Position the kettle in its permanent location, and level the kettle by turning the adjustable flanged feet. Once positioned and levelled, permanently secure the kettle's flanged feet to the floor using lag bolts and floor anchors (to be supplied by the installer).

KDP SERIES

1. Position the kettle in its permanent location, and mark the floor around the circumference of the base collar or the base plate. Locate the centre of this circle and mark the floor at this centre point. This is the point at which the kettle's base plate will be secured to the floor.
2. Lay kettle on its side (on a cushioned surface to prevent scratching), and slide the base collar up the pedestal, exposing the plate for removal.
3. Remove the four cap screws securing the base plate and slide it off the kettle.
4. Prepare the floor location, for mounting the kettle, by installing a 3/4" (19mm) stud, cast into the floor, at the base plate's centre point. Note: a 3/4" (19mm) lag bolt and floor anchor may be substituted for a cast-in stud. The anchor is installed in the floor, and the lag bolt is threaded down through the base plate, into the anchor, after completion of step 6.
5. Thread the four 3/8" (10mm) levelling bolts into plate from the top, and insert the plate over stud.
6. Adjust bolts until the plate is level.
7. Install a nut on the 3/4" (19mm) bolt (or insert a lag bolt if the alternate fastener method is used) and secure base plate to the floor.
8. Check for level "set" of the kettle by placing the kettle on the base plate with the screw holes aligned and applying a carpenter's level at the kettle rim. If the kettle is level, it may be fastened in place with the four cap screws. If the kettle is not level, the kettle must be removed from the base, the plate loosened, and the levelling bolts re-adjusted until a level installation is attained.
9. Slide the base collar down to the floor, and draw a line around the circumference of the pedestal at the top of the collar, using the top of the collar as a guide. Slide the collar back up the pedestal.
10. Apply a bead of silicone sealer to the circumference of the pedestal, at the line, and also to the bottom rim of the collar. Slide the collar down the pedestal and press it tightly to the floor. The silicone sealer will create a seal where the collar meets the pedestal, and where the collar meets the floor.

SERVICE CONNECTIONS

Install service connections as required. Locations and other data are shown on the Specification Sheet.

STEAM

All steam plumbing to and from the kettle and steam boiler should be thoroughly cleaned and inspected for dirt and debris before final connection to the kettle are made.

Check the rating plate for the maximum steam pressure that your kettle is rated for. If the steam supply pressure exceeds the rated pressure, a pressure reducing valve is required. The steam inlet is at the right side of the kettle, as seen from the front.

CONDENSATE

A steam condensate trap must be plumbed to a drain, using minimum 1/2" NPT plumbing. The condensate line is limited to a maximum rise of 10 feet in order for the steam pressure to adequately force the condensate through the plumbing. Any higher rise requires a pump.

If the steam boiler to which this kettle is installed has a condensate return (closed loop system), a 1/2" steam strainer, a 1/2" steam trap, and a 1/2" check valve must be installed on the output (condensate) side of the kettle.

FOR POWER TILT UNITS ONLY

NOTE: Ensure the electrical supply matches the kettle's requirements as stated on the rating label.

This kettle is built to comply with CE standards. Many local codes exist, and it is the responsibility of the owner and installer to comply with these codes.

NOTE: Maximum voltage for LVD is 440 volts for CE marked appliances.

POTABLE WATER

The water faucet (optional) with swing spout, requires 1/2 inch O.D. copper tube plumbing for hot or cold water supplies to the faucet (SPK - cold water connection only, DPK - hot and cold water connection).

FINAL INSTALLATION CHECK

1. Partially fill the kettle with water.
2. Slowly turn the steam supply valve's knob to the open position.
3. Release the safety valve, ensuring that the steam escapes freely. Stay clear of steam exhaust when releasing the safety valve.
4. Observe that the water in the kettle comes to a boil.
5. Close the steam supply valve.
6. Drain off the water in the kettle.

CLEANING

After installation the kettle must be thoroughly cleaned and sanitized prior to cooking. See CLEANING INSTRUCTIONS for detailed information and suggested cleaners.

RECOMMENDED PIPING SCHEMATICS

(all service connections shown supplied by others)

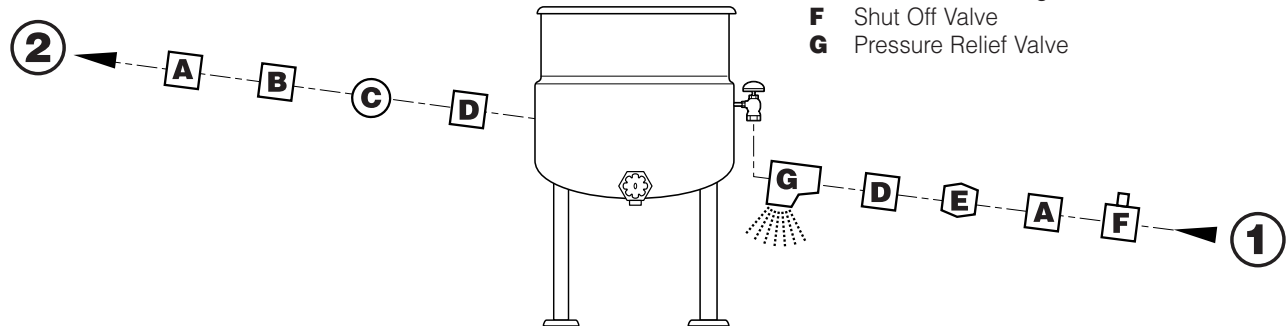

STEAM REQUIREMENTS FOR KETTLES

Kettle Cap. U.S. Gal.	Kettle Dia.	25 psi Steam 265°F		40 psi Steam 287°F		80 psi Steam 302°F	
		Lbs./Hr.	Hp./Hr.	Lbs./Hr.	Hp./Hr.	Lbs./Hr.	Hp./Hr.
40	26"	100	3	120	4	150	4.5
60	29.5"	150	4.5	190	5.5	230	7.0
80	33"	210	6.0	260	7.5	300	9.0
100	36"	260	7.5	320	9.5	390	11.0
125	40"	320	9.5	400	11.5	470	14.0
150	40"	390	11.0	480	14.0	570	17.0

- Steam requirements are maximum per hour.
- If more than one unit is on the same line then add the steam usage for each one to reach a total.

STEAM PIPE SIZING

Steam Required Lbs./Kg. per hour	Required pipe length in feet/meters		
	200 Ft. 60 Meters	400 Ft. 125 Meters	600 Ft. 185 Meters
100/45 Kg.	3/4"	1"	1 1/4"
200/91 Kg.	1"	1 1/4"	1 1/2"
300/136 Kg.	1"	1 1/4"	1 1/2"
400/182 Kg.	1"	1 1/2"	1 3/4"
500/227 Kg.	1 1/4"	1 1/2"	1 3/4"
700/318 Kg.	1 1/2"	1 3/4"	2"
900/409 Kg.	1 1/2"	1 3/4"	2"

NOTES:

- Pipe size in inches.
- Less than 50 PSI (3.4 BAR) pressure, increase pipe size by 1/4".
- 80 to 100 PSI (5.5 to 6.8 BAR), Decrease pipe size by 1/4".

OPERATING INSTRUCTIONS

CLEVELAND STEAM COOKING EQUIPMENT IS INTENDED FOR COMMERCIAL USE ONLY BY PROFESSIONALLY TRAINED PERSONNEL.



General Parts Drawing

ITEM # DESCRIPTION

- | | | |
|-----------|--------------------------------------|---|
| 1. | Steam Inlet Valve | Opens and closes the steam supply to the kettle. |
| 2. | Hand Wheel | Used for tilting the kettle up or down. Some units have an optional Power Tilt Control Switch located in the same position. |
| 3. | Power Tilt Switch
(not shown) | Used for tilting the kettle up or down. |
| 4. | Drain Cock | Used to drain condensate from the bottom of tilting units only. |
| 5. | Tangent Draw-Off Valve | Used for draining product or wash water from kettle. It is supplied as standard equipment on stationary kettles and is optional on tilting kettles. |
| 6. | Pressure Relief Valve
(not shown) | In the unlikely event that there is an excess steam build-up in the jacket, this valve automatically opens to relieve this pressure. |

OPERATION

1. Ensure that there is an adequate steam supply to the kettle.
2. For optimum performance on free-standing floor model tilting kettles, open drain cock to drain condensate from the kettle's jacket, then close drain cock before applying steam to a cold kettle.
3. If the kettle is equipped with a tangent draw-off valve, ensure that it is closed before filling the kettle. To keep solid food particles out of the draw-off valve, place either a solid or a perforated strainer in the bottom of the kettle.

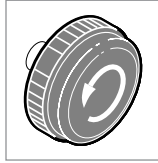

4. Turn the steam control valve to the open position by turning the knob counter-clockwise, then allow the kettle to preheat.

NOTE: When cooking egg and milk products, the kettle should NOT be preheated, as products of this nature adhere to hot cooking surfaces. These types of foods should be placed in the kettle before heating is begun.

5. Fill kettle with product to desired level.

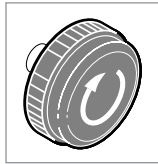

6. When the product has reached the desired temperature, regulate the heat, as required, by turning the steam control valve clockwise for less steam, and therefore, a lower temperature.

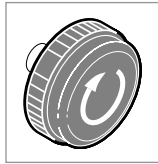

7. When cooking is complete, close the steam control valve by turning the knob clockwise.

8. Power tilt kettles are provided with a rocker-type center-off switch for raising and lowering the kettle. To raise the kettle, press the top of the switch. To lower the kettle, press the bottom of the switch. Release the switch, allowing it to return to the center "off" position when the desired degree of tilt has been reached. Limit switches are provided that automatically stop the tilt motion at the maximum limit of movement in either direction.

To raise and lower a manual tilt kettle, turn the handwheel counter-clockwise to lower and clockwise to raise.

FOR KETTLE/STEAMER COMBINATIONS:

If the boiler in a steamer is supplying steam to a kettle, always heat the kettle first. After the kettle contents are heated, and the boiler's steam pressure returns to normal, the steamer may be used. Pressure steamer compartments should be sequentially started, and preheated before cooking.

NOTE: As with cleaning food soil from any cookware, an important part of kettle cleaning is to prevent food from drying on. For this reason, cleaning should be completed immediately after cooked foods are removed. Please read the "Care and Cleaning" instructions for detailed kettle washing procedures.





CLEANING INSTRUCTIONS



CARE AND CLEANING

Cooking equipment must be cleaned regularly to maintain its fast, efficient cooking performance and to ensure its continued safe, reliable operation. The best time to clean is shortly after each use (allow unit to cool to a safe temperature).

WARNINGS

- ⇒  Do not use detergents or cleansers that are chloride based or contain quaternary salt.
Chloride Cleaners
- ⇒  Do not use a metal bristle brush or scraper.
Wire Brush &
- ⇒  Steel wool should never be used for cleaning the stainless steel.
Steel Pads
- ⇒  Unit should never be cleaned with a high pressure spray hose.
High Pressure Spray Hose
- ⇒  Do not leave water sitting in unit when not in use.
Stagnant Water

CLEANING INSTRUCTIONS

1. Turn unit off.
2. Remove drain screen (if applicable). Thoroughly wash and rinse the screen either in a sink or a dishwasher.
3. Prepare a warm water and mild detergent solution in the unit.
4. Remove food soil using a nylon brush.
5. Loosen food which is stuck by allowing it to soak at a low temperature setting.
6. Drain unit.
7. Rinse interior thoroughly.
8. If the unit is equipped with a **Tangent Draw-Off Valve**, clean as follows:
 - a) Disassemble the draw-off valve first by turning the valve knob counter-clockwise, then turning the large hex nut counter-clockwise until the valve stem is free of the valve body.
 - b) In a sink, wash and rinse the inside of the valve body using a nylon brush.
 - c) Use a nylon brush to clean tangent draw-off tube.
 - d) Rinse with fresh water.
 - e) Reassemble the draw-off valve by reversing the procedure for disassembly. The valve's hex nut should be hand tight only.
9. If the unit is equipped with a **Butterfly Valve**, clean as follows:
 - a) Place valve in open position.
 - b) Wash using a warm water and mild detergent solution.
 - c) Remove food deposits using a nylon brush.
 - d) Rinse with fresh water.
 - e) Leave valve open when unit is not in use.
10. Using mild soapy water and a damp sponge, wash the exterior, rinse, and dry.

NOTES

- ⇒ For more difficult cleaning applications one of the following can be used: alcohol, baking soda, vinegar, or a solution of ammonia in water.
- ⇒ Leave the cover off when the kettle is not in use.
- ⇒ For more detailed instructions refer to the Nafem Stainless Steel Equipment Care and Cleaning manual (supplied with unit).

STAINLESS STEEL EQUIPMENT CARE AND CLEANING

(Supplied courtesy of Nafem. For more information visit their web site at www.nafem.org)

Contrary to popular belief, stainless steels ARE susceptible to rusting.

Corrosion on metals is everywhere. It is recognized quickly on iron and steel as unsightly yellow/orange rust. Such metals are called "active" because they actively corrode in a natural environment when their atoms combine with oxygen to form rust.

Stainless steels are passive metals because they contain other metals, like chromium, nickel and manganese that stabilize the atoms. 400 series stainless steels are called ferritic, contain chromium, and are magnetic; 300 series stainless steels are called austenitic, contain chromium and nickel; and 200 series stainless, also austenitic, contains manganese, nitrogen and carbon. Austenitic types of stainless are not magnetic, and generally provide greater resistance to corrosion than ferritic types.

With 12-30 percent chromium, an invisible passive film covers the steel's surface acting as a shield against corrosion. As long as the film is intact and not broken or contaminated, the metal is passive and stain-less. If the passive film of stainless steel has been broken, equipment starts to corrode. At its end, it rusts.

Enemies of Stainless Steel

There are three basic things which can break down stainless steel's passivity layer and allow corrosion to occur.

1. Mechanical abrasion
2. Deposits and water
3. Chlorides

Mechanical abrasion means those things that will scratch a steel surface. Steel pads, wire brushes and scrapers are prime examples.

Water comes out of the faucet in varying degrees of hardness. Depending on what part of the country you live in, you may have hard or soft water. Hard water may leave spots, and when heated leave deposits behind that if left to sit, will break down the passive layer and rust stainless steel. Other deposits from food preparation and service must be properly removed.

Chlorides are found nearly everywhere. They are in water, food and table salt. One of the worst chloride perpetrators can come from household and industrial cleaners.

So what does all this mean? Don't Despair!

Here are a few steps that can help prevent stainless steel rust.

1. Use the proper tools.

When cleaning stainless steel products, use non-abrasive tools. Soft cloths and plastic scouring pads will not harm steel's passive layer. Stainless steel pads also can be used but the scrubbing motion must be in the direction of the manufacturers' polishing marks.

2. Clean with the polish lines.

Some stainless steel comes with visible polishing lines or "grain." When visible lines are present, always scrub in a motion parallel to the lines. When the grain cannot be seen, play it safe and use a soft cloth or plastic scouring pad.

3. Use alkaline, alkaline chlorinated or non-chloride containing cleaners.

While many traditional cleaners are loaded with chlorides, the industry is providing an ever-increasing choice of non-chloride cleaners. If you are not sure of chloride content in the cleaner used, contact your cleaner supplier. If your present cleaner contains chlorides, ask your supplier if they have an alternative. Avoid cleaners containing quaternary salts; it also can attack stainless steel and cause pitting and rusting.

4. Treat your water.

Though this is not always practical, softening hard water can do much to reduce deposits. There are certain filters that can be installed to remove distasteful and corrosive elements. To insure proper water treatment, call a treatment specialist.

5. Keep your food equipment clean.

Use alkaline, alkaline chlorinated or non-chloride cleaners at recommended strength. Clean frequently to avoid build-up of hard, stubborn stains. If you boil water in stainless steel equipment, remember the single most likely cause of damage is chlorides in the water. Heating cleaners that contain chlorides have a similar effect.

6. Rinse, rinse, rinse.

If chlorinated cleaners are used, rinse and wipe equipment and supplies dry immediately. The sooner you wipe off standing water, especially when it contains cleaning agents, the better. After wiping equipment down, allow it to air dry; oxygen helps maintain the stainless steel's passivity film.

7. Never use hydrochloric acid (muriatic acid) on stainless steel.

8. Regularly restore/passivate stainless steel.

Recommended cleaners for specific situations

Job	Cleaning Agent	Comments
Routine cleaning	Soap, ammonia, detergent, Medallion	Apply with cloth or sponge
Fingerprints & smears	Arcal 20, Lac-O-Nu Ecoshine	Provides barrier film
Stubborn stains & discoloration	Cameo, Talc, Zud, First Impression	Rub in direction of polish lines
Grease & fatty acids, blood, burnt-on-foods	Easy-off, De-Grease It Oven Aid	Excellent removal on all finishes
Grease & oil	Any good commercial detergent	Apply with sponge or cloth
Restoration/Passivation	Benefit, Super Sheen	

Review

1. Stainless steels rust when passivity (film-shield) breaks down as a result of scrapes, scratches, deposits and chlorides.
2. Stainless steel rust starts with pits and cracks.
3. Use the proper tools. Do not use steel pads, wire brushes or scrapers to clean stainless steel.
4. Use non-chlorinated cleaners at recommended concentrations. Use only chloride-free cleaners.
5. Soften your water. Use filters and softeners whenever possible.
6. Wipe off cleaning agent(s) and standing water as soon as possible. Prolonged contact causes eventual problems.

To learn more about chloride-stress corrosion and how to prevent it, contact the equipment manufacturer or cleaning materials supplier.

Developed by Packer Engineering, Naperville, Ill., an independent testing laboratory.

SERVICE PARTS

WARRANTY

Our Company supports a worldwide network of Maintenance and Repair Centers. Contact your nearest Maintenance and Repair Centre for replacement parts, service, or information regarding the proper maintenance and repair of your cooking equipment

In order to preserve the various agency safety certification (UL, NSF, ASME/Ntl. Bd., etc.), only factory-supplied replacement parts should be used. The use of other than factory supplied replacement parts will void warranty.

FAUCET ASSEMBLY

ITEM NO.	PART NO.	DESCRIPTION	QTY.
<i>3/4" Spouts</i>			
1.	KE50825-2	KDL-60/80/100-T, KDP-60/80-T	1
	KE50825-3	KDL-25/40-T, KDP-25/30/40-T	1
	KE50825-7	KDL-40/60/80-TSH,	1
	KE50825-5	ALL STATIONARY KETTLES	1
2.	FA95022	Retaining Ring	1
3.	FA05002-19	"O" Ring	1
4.	KE51736	Long Faucet Nut	1
5.	SE50020	Hot Water Stem Assembly (Double Pantry only)	1
6.	SE50021	Cold Water Stem Assembly	1
7.	KE51401	Single Pantry Body (c/w Item No. 6)	1
8.	KE50335	Adapter Washer (Single Pantry only)	1
9.	KE51403	Double Pantry Body (c/w Item No. 5&6)	1
10.	KE54159	Faucet Mounting Bracket	1
11.	FA11258	Hex Cap Screw	2
12.	FA30505	Washer	2
13.	FA21008	Hex Nut	2
14.	SE50447	Washer Horseshoe	1

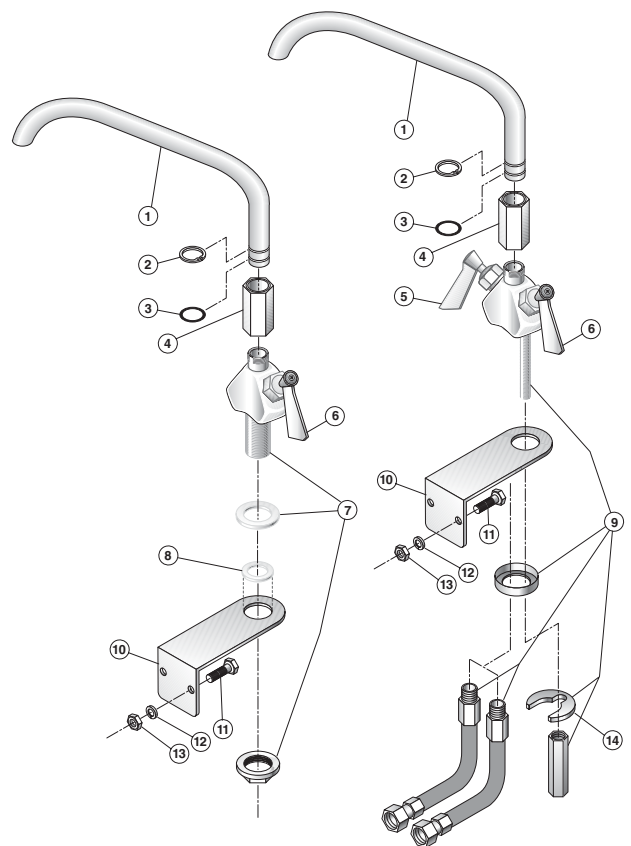

STEAM CONTROL ASSEMBLIES

SE50441-2
Stem only

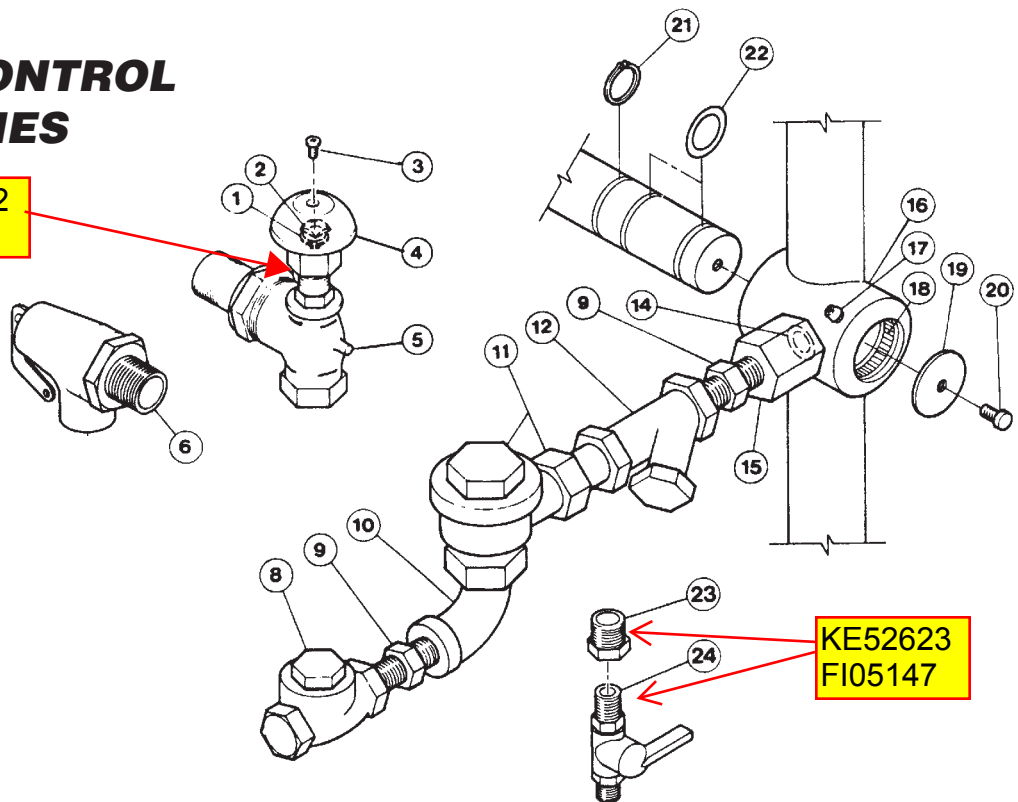

ITEM NO.	PART NO.	DESCRIPTION	QTY.
1.	KE51892	Retaining ring	1
2.	KE51888	Washer	1
3.	FA11501	Valve knob screw	1
4.	SE00028	Valve knob assembly (includes item 1, 2, 3)	1
5.	KE02055-3	3/4" Chrome steam inlet valve	1
6.	KE54941-2	3/4" Pressure relief valve, 50 psi, up to 100 gallon	1
	KE54941-15	3/4" Pressure relief valve, 100 psi, up to 100 gallon	1
	KE54941-11	3/4" Pressure relief valve, 35 psi, 125 gallon and up	1
	KE54941-12	3/4" Pressure relief valve, 100 psi, 125 gallon and up	1
8.	KE52700	1/2" Check valve	1
9.	FI05271-6	Nipple 1/2" NPT x 1 1/2" long	2
10.	FI05078	90° Elbow (chrome plated)	2
11.	KE52701	1/2" Steam trap	1
12.	KE52702	1/2" Strainer	1
14.	FA05002-16	"O" Ring	1
15.	KE50676	Connector	1
16.	KE00353	Trunnion bearing, spring assist cover (includes items 15, 17 & 18)	1
	KE00352	Trunnion bearing, no cover (includes items 15, 17 & 18)	1
17.	KE51886	Grease nipple	2
18.	KE51711	Roller Bearing	2
19.	KE50666	Spherical washer	1
20.	FA95081-3	Bolt, 5/16"-18 x 1/2"	1
21.	FA95007-1	Retaining ring	1
22.	FA05002-6	"O" Ring	2
23.	FI00352	Reducer bushing 1/2 x 3/8	1
24.	KE50675	Drain cock	1

CONTROL CONSOLE COMPONENTS - HAND TILT

ITEM NO.	PART NO.	DESCRIPTION	QTY.
1.	FA11134	Screw, #1-24	2
2.	FA11501	Screw	1
3.	SE00028	Valve Knob (Item no. 2 included)	1
4.	KE00350	Brass Steam Inlet Valve & Stem, 3/4" (Item no. 2 & 3 not included)	KE02055-2
	SE50441-2	Replacement Stem (without valve)	1
5.	FA95008	Lock Nut, 3/4-16	2
6.	FA30088	Washer, tilt shaft	1
7.	SE00036	Thrust Bearing Assembly (Item no. 27, 28, & 29 included)	2
8.	FA95007-1	Retaining Ring (25-60 gallon)	1
	FA95007-4	Retaining Ring (80 gallon & up)	1
9.	FA05002-6	"O" Ring (25-60 gallon)	2
	FA05002-27	"O" Ring (80 gallon & up)	2
10.	FA95055-4	Key, worm gear (25-60 gallon)	1
	FA95055-7	Key, worm gear (80 gallon & up)	1
11.	KE51711	Roller Bearing, trunnion (25-60 gallon)	2
	KE517111	Roller Bearing, trunnion (80 gallon & up)	2
12.	FA95005	Tension Pin	1
13.	KE503751	Tilt Shaft	1
14.	FA19505	Allen Screw, hand wheel	1
15.	KE00508	Hand Wheel	1
16.	KE00164-1	Trunnion Bearing Housing (25-60 gallon)	1
	KE00164-2	Trunnion Bearing Housing (80 gallon & up)	1
17.	KE00151	Segment Gear (25-60 gallon)	1
	KE52833	Segment Gear (80 gallon & up)	1
18.	FA19186	Allen Screw, worm gear	1
19.	KE50315	Worm	1
20.	KE55057-6	Gear Box Lid (25-60 gallon)	1
	KE55057-5	Gear Box Lid (80 gallon & up)	1
21.	KE51730	Bearing, tilt shaft	1
22-24	SE00036	Assembly	1
22.	KE51891	Washer, 1 1/2" O.D. x 13/16" I.D. x .037" W.	1
23.	T40226	Bearing Assembly	1
24.	FA20029	Hex Nut, 5/16-24	1
25.	FA10623	Bolt, 5/16-24 x 1 1/2"	1
27.	KE52192	Washer, thrust bearing	2
28.	KE52191	Bearing, thrust	1
29.	KE52193	Spacer, thrust bearing	1
30.	KE50426-4	Spacer	1

CONTROL CONSOLE COMPONENTS - POWER TILT

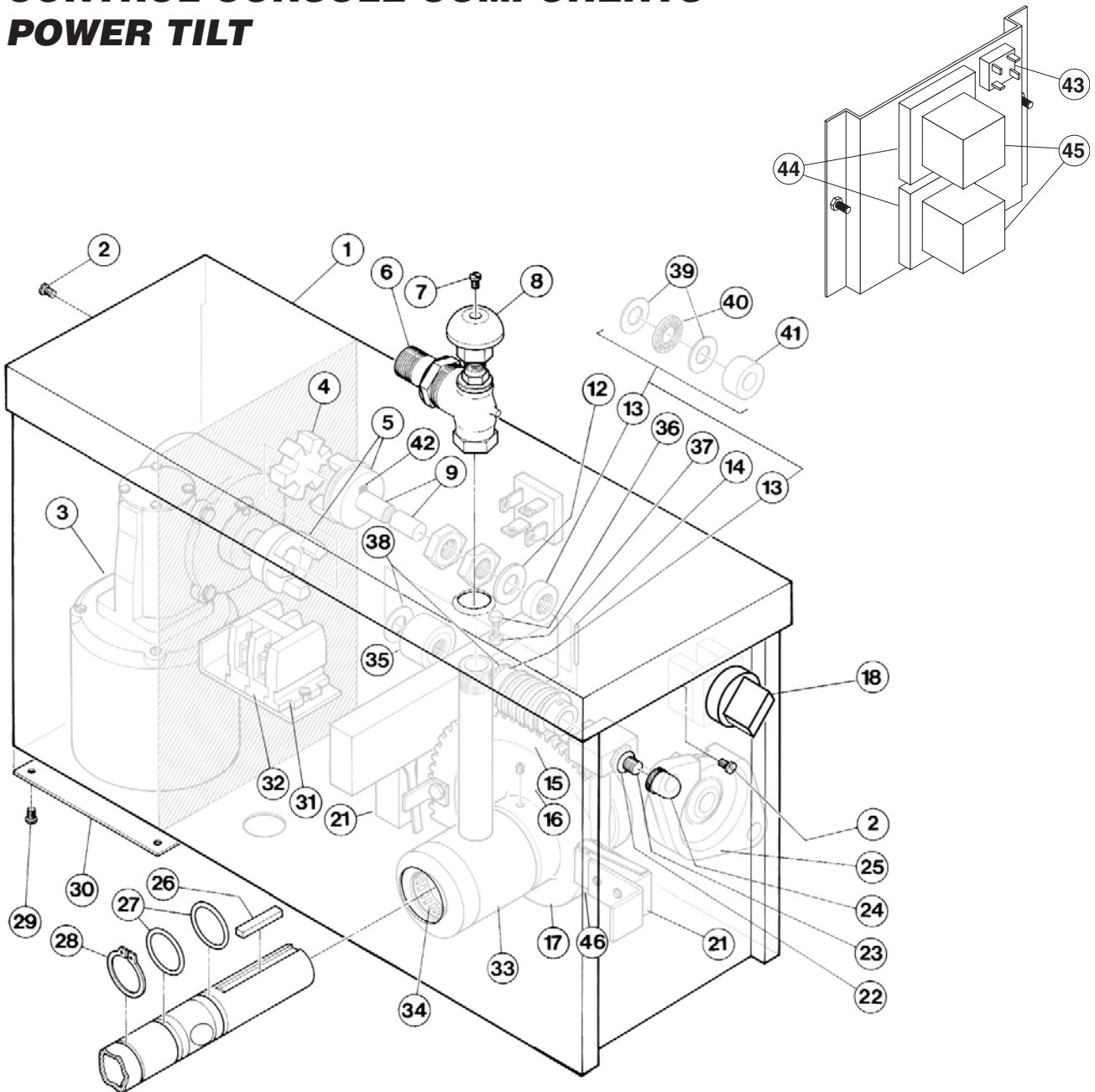

ITEM NO.	PART NO.	DESCRIPTION	QTY.
1.	KE55057-10	Gear Box Lid (25-60 gallon)	1
	KE55057-3	Gear Box Lid (80 gallon & up)	1
2.	FA11134	Screw, 10-24 x 3/8" SS	1
3.	KE52832-1	Motor	1
4.	KE50583	Buna-N Insert	1
5.	KE50582	Coupling	2
6.	KE02055-2	Brass Steam Inlet Valve & Stem, 3/4" (Item no. 7 & 8 not included)	1
	SE50441-2	Replacement Stem (without valve)	1
7.	FA11501	Screw	1

CONTROL CONSOLE COMPONENTS - POWER TILT

ITEM NO.	PART NO.	DESCRIPTION	QTY.
8.	SE00028	Steam Inlet Knob Assembly (Item no. 7 included)	1
9.	KE50441	Tilt Shaft	1
10.	FA95008	Locknut, 3/4-16	2
12.	FA30088	Washer, 1 1/2" O.D. x 13/16" I.D. x .125 W.	1
13.	SE00036	Bearing Assembly	2
14.	FA95005	Tension Pin	1
15.	KE50315	Worm	1
16.	FA19186	Allen Screw, worm gear	1
17.	KE00151	Segment Gear (25-60 gallon)	1
	KE52833	Segment Gear (80 gallon & up)	1
18.	KE003209-11	Complete Switch	1
	KE603208-4	Momentary Switch Activator***	1
	KE603208-7	Contact Section Holder, Latch***	1
	KE603208-9	Contact Block***	4
***NOTE: for units built prior to Dec. 2006 order Complete Switch KE003209-11			
21.	KE51007	Micro Switch	2
22.	FA00012	"O" Ring, circuit breaker	1
23.	KE50579-1	Circuit Breaker, 1 amp.	1
24.	KE50580	Water Resistant Boot	1
25.	KE51731	Bearing, tilt shaft	1
26.	FA95055-4	Key, worm gear (25-60 gallon)	1
	FA95055-7	Key, worm gear (80 gallon & up)	1
27.	FA05002-6	"O" Ring (25-60 gallon)	4
	FA05002-27	"O" Ring (80 gallon & up)	4
28.	FA95007-1	Retaining Ring (25-60 gallon)	1
	FA95007-4	Retaining Ring (80 gallon & up)	1
29.	FA11092	Screw, 8-32 x 1/2" SS	4
31.	KE50376	Terminal Block End Section (large, white)	1
	SK50054	Terminal Block End Section (small, black)	1
32.	KE50377	Terminal Block Section (large, white)	3
	SK50055	Terminal Block Section (small, black)	3
33.	KE00164	Trunnion Bearing Housing (25-60 gallon)	1
	KE01347	Trunnion Bearing Housing (80 gallon & up)	1
34.	KE51711	Roller Bearing, trunnion (25-60 gallon)	2
	KE51711-1	Roller Bearing, trunnion (80 gallon & up)	2
35.	T40226	Bearing Assembly	1
36.	FA10623	Bolt, 5/16-24 x 1 1/2"	1
37.	FA20029	Nut, hex, 5/16-24	1
38.	KE51891	Washer, 1 1/2" O.D. x 13/16" I.D. x .037" W.	2
39.	KE52192	Washer, thrust bearing	4
40.	KE52191	Bearing, thrust	2
41.	KE52193	Spacer, thrust bearing	2
42.	FA95037	Key, 3/16" x 3/16" x 3/4"	1
43.	KE50581	Bridge Rectifier	1
44.	KE54535	Edge Connector (11 pin)	2
45.	KE50753-10	Relay	2
46.	KE50426-4	Spacer	1

HINGE ASSEMBLY

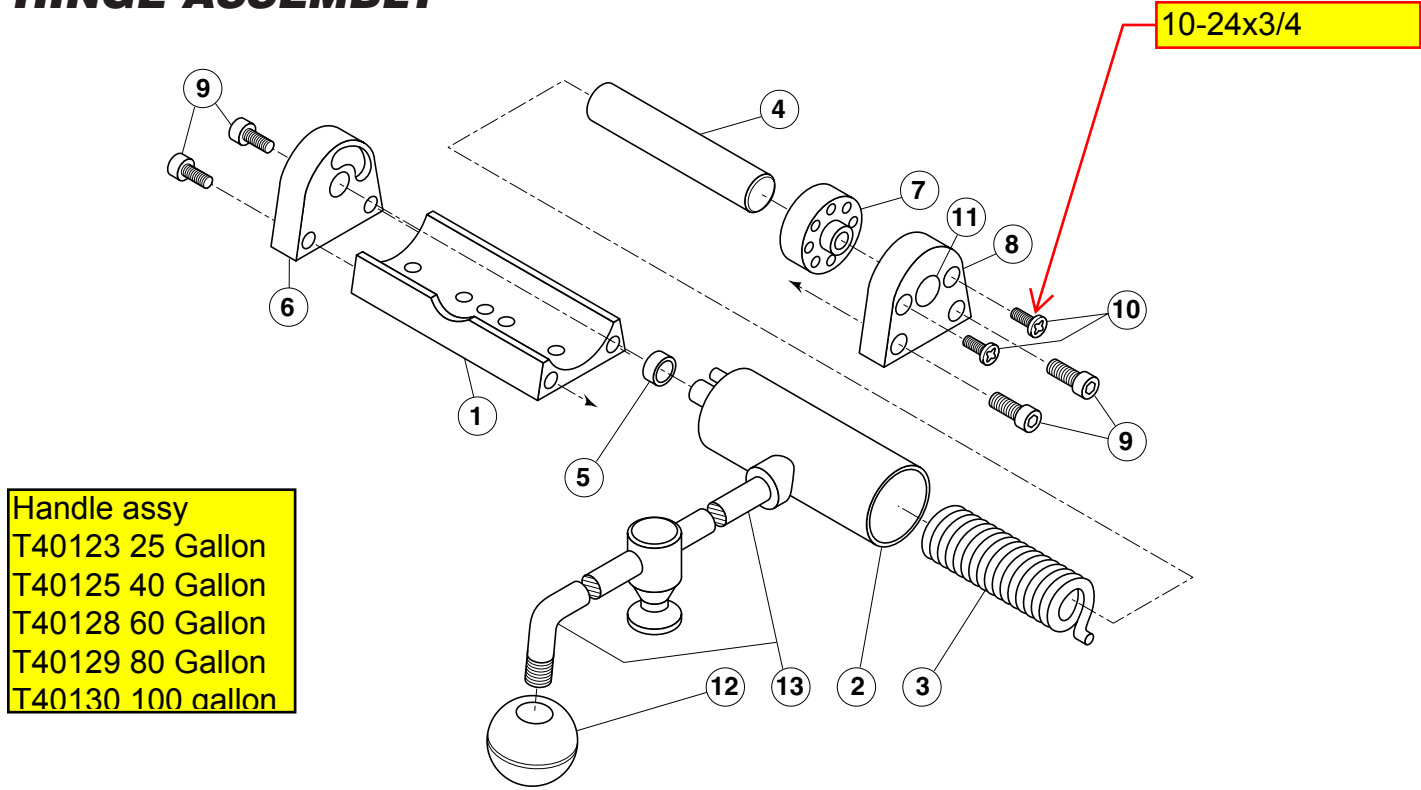

Handle assy
 T40123 25 Gallon
 T40125 40 Gallon
 T40128 60 Gallon
 T40129 80 Gallon
 T40130 100 gallon

ITEM NO.	PART NO.	DESCRIPTION	QTY.
Hinge Assembly			
1. - 11	KE00597-1	25 - 40 Gallon, 20 Gallon Full Jacketed	1
	KE00597-2	60 - 80 Gallon, 30 - 40 Gallon Full Jacketed	1
	KE00597-3	100 - 150 Gallon, 60 - 100 Gallon Full Jacketed	1
	KE00597-4	KDM-60, KDM-60-T, Cook Tank	1
	KE00597-5	KDL-200, KDL-250, KDL-150-F, KDL-250-F	1
1.	KE50822	Hinge Base	1
2.	KE51217	Hinge Cylinder	1
3.	KE50121-2	Hinge Spring Light - for KE50597-2	1
	KE50121-1	Hinge Spring Heavy - for KE50597-1, KE50597-3, KE50597-4, KE50597-5, .	1
4.	KE50823-1	Hinge Pin	1
5.	KE50824	Hinge Bearing	1
6.	KE50819-1	Hinge End Piece	1
7.	KE50820	Hinge Insert	1
8.	KE50819	Hinge End Piece	1
9.	FA11284	Screw, Socket Head	4
10.	FA11507	Cutting Screw,	2
11.	SK50418	Plug Button	1
12.	KE50151-2	Knob	1
13.		Cover Handle (specify model)	1

TANGENT DRAW-OFF VALVE

KE52752-1 piston after 2012
 FA05002-55 Piston oring

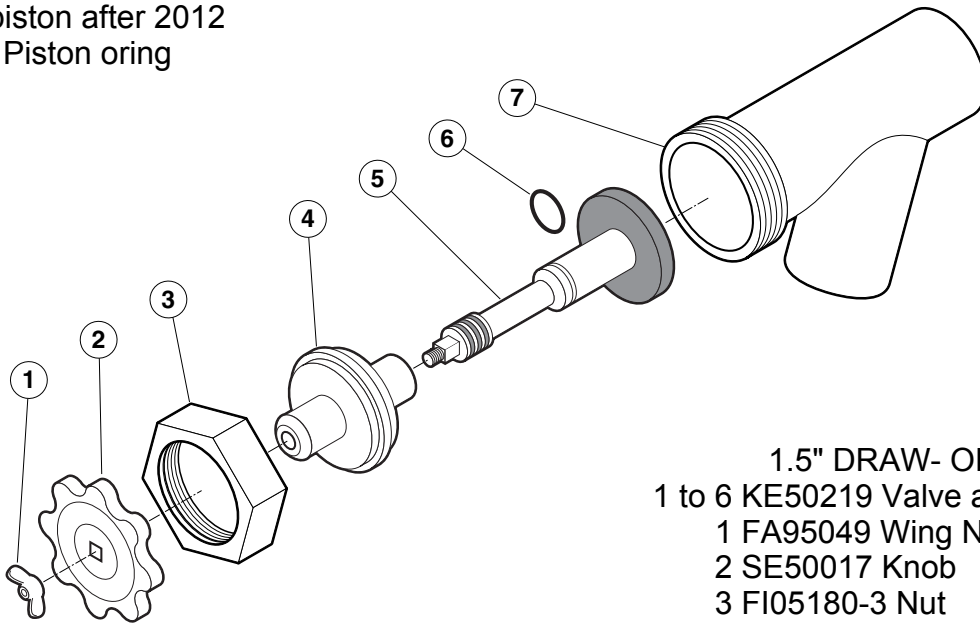

1.5" DRAW- OFF
 1 to 6 KE50219 Valve assembly complete
 1 FA95049 Wing Nut
 2 SE50017 Knob
 3 FI05180-3 Nut
 4 SE50011 Retainer 1.5"
 5 SE50008 Piston TD-1 1/2
 6 FA05002-24 "O"ring

ITEM NO.	PART NO.	DESCRIPTION	QTY.
1. - 7.	KE50972	2" DRAW-OFF ASSEMBLY	1
	KE50973	3" DRAW-OFF ASSEMBLY	1
1.	FA95049	WING NUT, TD-2	1
	FA21050	ACCORN NUT, TD-2	1
	FA21501-1	ACCORN NUT, TD-3	1
2.	KE52755	KNOB, TD-2	1
	SE50018	KNOB, TD-3	1
3.	FI05180-1	HEX NUT, TD-2	1
	FI05180-2	HEX NUT, TD-3	1
4.	KE52753	RETAINER, TD-2	1
	SE50013	RETAINER, TD-3	1
5.	KE52752	PISTON, TD-2	1
	SE50010	PISTON, TD-3	1
6.	FA05002-24	"O" RING, TD-2	1
	FA05002-38	"O" RING, TD-3	1
7.	KE50972-B	VALVE BODY, TD-2	1
	KE50973	VALVE BODY, TD-3	1

#	DESCRIPTION	DATE	APPROVED
E	15/16 WAS 9/16; 1 5/8 WAS 1 1/4	02/06/2012	NPOYLOVA

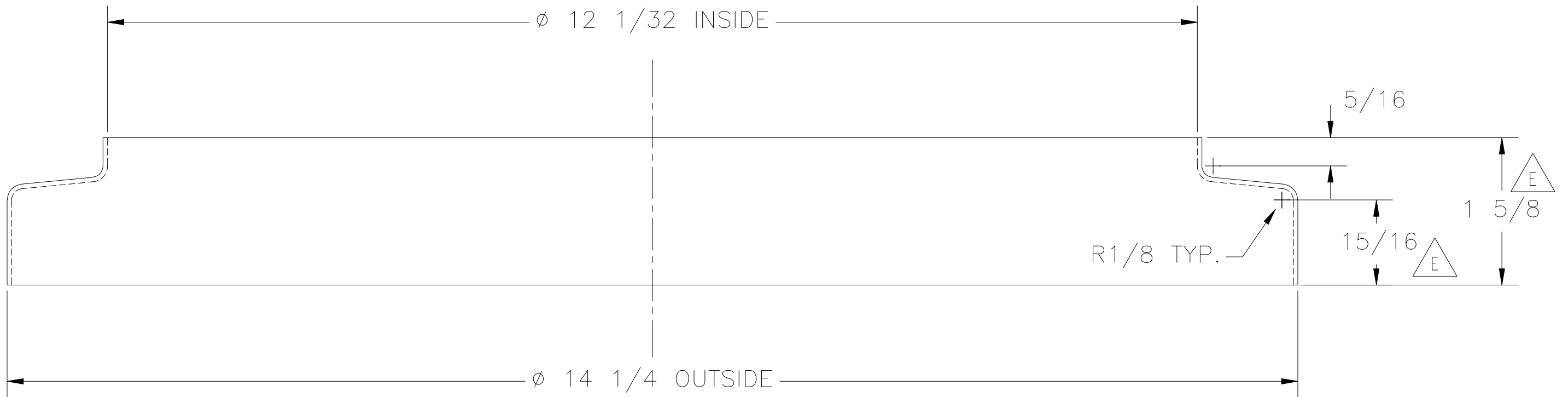

BLANK SIZE $16 \frac{1}{4} \times 16 \frac{1}{4}$

THIS DESIGN COVERS A PROPRIETARY ITEM AND IS THE PROPERTY OF CLEVELAND RANGE LTD. THIS DRAWING IS NOT TO BE COPIED OR USED WITHOUT THE APPROVAL OF CLEVELAND RANGE LTD.		FOR GENERAL TOLERANCES REFER TO FWI-043		CLEVELAND RANGE LTD. 8251 KEELE STREET, CONCORD, ONTARIO, CANADA		TITLE COVER; PEDESTAL BASE KDP	
MATERIAL	S.S.	DO NOT SCALE PRINTED DRAWING	DRAWN BY SAAD	DATE 09/15/2003	SIZE B	DRAWING NO. KE50185	SHEET 1 OF 1
TYPE & GRADE	304						
FORM	SHEET						
FINISH	2B						
SIZE	18 GA (.048"THICK)					REV E	

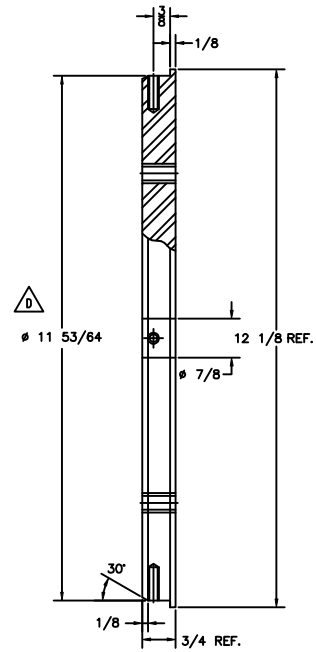
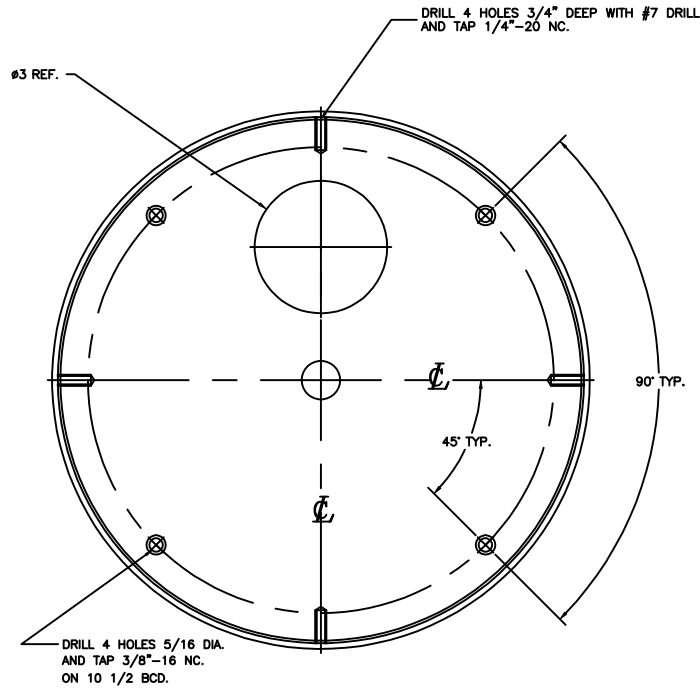

NOTE: FINISH: ZINC PLATED OR PAINTED ALUMINUM.
WAS DWG-J 01446-0005

MATERIAL: KES0183R

KDP
PEDESTAL BASE PLATE

TOLERANCES (UNLESS OTHERWISE SPECIFIED)	
FRACTIONAL	±1/32
DECIMAL	±0.005
ANGULAR	±1/2°
DO NOT USE REF. DIMENSIONS	

Cleveland Range Ltd.
8881 Route 9,
Caledon, Ontario
CANADA

REV. No.	REV. DATE	DESCRIPTION	DESIGNED BY	DESIGN No.
D	10/18/2001	3RTS		KES0183
C	03/24/1999	ODS		
B	07/27/1991	3" DIA. HOLE ADDED		
A	02/18/1981	RELEASED		
DATE MADE			DRAWN BY	
10/18/2001			SMD	

MAINTENANCE

ALL SERVICE MUST BE PERFORMED BY A QUALIFIED SERVICE TECHNICIAN.

This kettle requires very little preventative maintenance other than daily cleaning.
The pressure relief valve must be tested twice a year.

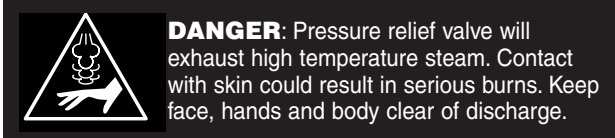

PRESSURE RELIEF VALVE TESTING PROCEDURE

The pressure relief valve must be checked at least twice a year as part of the normal maintenance performed.

1. With the kettle empty, fully open the steam valve and allow the kettle to preheat.
 2. Stand to the side of the pressure relief valve discharge tube and pull valve open for a maximum of one second. Repeat test three to four times. Each time the mechanism should move freely and be accompanied by a rapid escape of steam.
- ⇒ If valve appears to be sticking replace pressure relief valve.
⇒ If foreign material is discharged then drain kettle and replace pressure relief valve.

WARNING: Improper refilling of kettle jacket will result in irreversible damage to unit.

STEAM TRAP

To remove line condensate that forms inside the steam jacket, each kettle should be equipped with a steam trap in the line of the kettle outlet to the drain. A good steam trap at startup releases air and wet steam into the drain line for a few minutes, then holds the steam jacket. During cooking, the trap periodically releases accumulated condensate. If the kettle's cooking performance becomes inadequate after long use, replacement of the steam trap with a new one may restore kettle operation to peak efficiency.

DRAW-OFF VALVE

To correct a leak at the draw-off valve, the source of the leak must first be determined. Leaks from around the valve stem are corrected by simply replacing the "O" ring. Faulty seating of the valve stem disc against the valve body may cause dripping from the valve even when the valve is tightly closed. This can often be corrected by cleaning any residue from the disc and seat.

LUBRICATION PROCEDURE

Lubricate the following parts every three months to insure smooth operation and reduce wear.

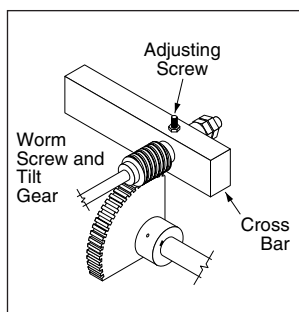

TRUNNION HOUSING, WORM SCREW AND TILT GEAR

These parts are accessed through the top cover of the console.

Apply grease to gear teeth. Check for excessive play and adjust with adjusting

screw located on top of cross bar.

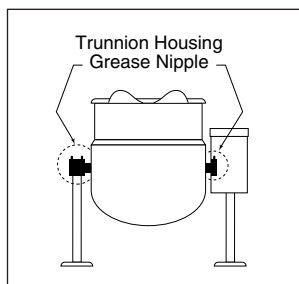

KETTLE TRUNNIONS

On the left hand side of the kettle there are two grease nipples on the top back portion of the trunnion housing. On the right hand side of the kettle you must remove the console cover to access the grease nipple.

HINGE ADJUSTMENT INSTRUCTIONS

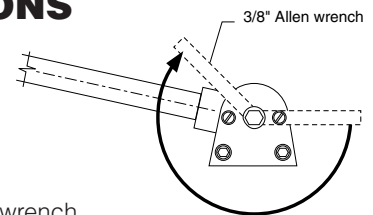

1. Insert 3/8" Allen wrench.
2. Turn clockwise to relieve tension on spring.
3. While tension is released remove one of the two slotted screws.
4. To prevent Allen wrench from springing back abruptly while the second slotted screw is removed, insert a pin (approximately 1/8") in the hole where the first slotted screw was removed from.
5. Remove second slotted screw.
6. While holding Allen wrench remove pin.
7. Turn Allen wrench clockwise to tighten or counter-clockwise to loosen tension to produce desired effect.
8. Re-insert pin in one of the two holes.
9. Tighten one slotted screw in the other hole (it may be necessary to turn Allen wrench slightly to align holes).
10. Remove pin and repeat step number 9. for other slotted screw.

TROUBLESHOOTING GUIDE

This section contains information intended for use by Authorized Service Personnel only.

PROBLEM

A/ Kettle heats too slowly or does not come to a boil.

- | Probable Cause | Remedy |
|--|--|
| 1. Inadequate steam flow. | Check for correct steam using chart below.
If kettle is connected to a steamer and powered by a generator the units should be operated sequentially (kettle boiling first, then start steamer). |
| 2. Steam trap not operating properly. | The trap should open periodically to dump condensate, then close.
If it does not open or close it should be cleaned or replaced. |
| 3. Food batches are not always the same. | When checking make certain that the original state (ie. fresh or frozen) and quantity of food product is the same. |

PROBLEM

B/ The trunnion housing leaks steam.

- | Probable Cause | Remedy |
|---------------------------------|-------------------|
| 1. Trunnion "O" rings are worn. | Replace "O" rings |

PROBLEM

B/ The steam trap makes a banging noise when steam applied to cold kettle.

- | Probable Cause | Remedy |
|--|---|
| 1. Kettle condensate has not been drained. | On all tilting models the condensate should be drained from the cold kettle. This is done before steam is applied using the drain cock valve on the bottom of the kettle. |

WIRING DIAGRAM

Power Tilt Units Only
115 Volts, 1PH, 50/60HZ

