

# SHORT SERIES™ DIRECT STEAM KETTLES

35" RIM HEIGHT, TILTING  
FULL STEAM JACKETED  
40 OR 60 GALLONS (150 OR 225 LITERS)

Project \_\_\_\_\_  
 Item \_\_\_\_\_  
 Quantity \_\_\_\_\_  
 FCSI Section 11400 \_\_\_\_\_  
 Approved \_\_\_\_\_  
 Date \_\_\_\_\_

## Models

- KDL-40-TSH
- KDL-60-TSH
- KDL-80-TSH



Shown with optional Spring Assisted Cover and 2" Tangent Draw-Off Valve

## Standard Features

- Support Legs with level adjustable feet, flanged for floor bolting.
- Type 304 Stainless Steel construction, with #4 finish on kettle and supports.
- Tilting Mechanism with permanently lubricated, Self-locking, Worm Drive of space saving design.
- 50 psi Steam Jacket Rating
- 50 psi Chrome - Plated Safety Valve.
- Large pouring lip for easier, faster, pouring. Heavy-duty Rolled Rim design provides strong reinforcement, prevents damages from abuse.
- Condensate Drain Valve with insulated handle.
- Steam Control Inlet Valve.
- Typical approvals include NSF and ASME.

## Short Form Specifications

Cleveland Direct Steam Tilting Kettle, Model KDL-\_\_\_-TSH, 35" rim height. Type 304 Stainless Steel and Supports. Fully Steam Jacketed, 50 psi Steam Jacket Rating; heavy reinforced Rolled Rim. Tri-Leg Type with adjustable Flanged Feet.

## Options & Accessories

- 316 Stainless Steel Liner (316)
- 2" Tangent Draw-Off Valve (TD2)
- Kettle Markings (KM)
- Spring Assist Cover (CHS)
- Lift Off Cover (CL)
- Basket Strainer (BS)
- Measuring Strip (MS)
- Food Strainer (FS)
- Factory Installed Steam Control Kit, consisting of a Steam Trap, condensate Strainer and Check Valve. (SCK1)
- Hot and cold water faucet (DPK), or cold water (SPK). Requires faucet bracket (FBKT)
- Pan Carriers (PCK)
- Kettle Accessory Kit (KAK)
- Tri-Basket Strainer Support System (TBS)
- Pressure Reducing Valve for regulating incoming steam pressure over 45psi (PRVK)
- Correctional Packages
- Heat Deflector Shield (HS001)

KE004046-53

CAPACITIES: (in 8 oz. servings, other sizes may be calculated.)  
 40 Gallon / 150 liters . . . 640 servings  
 60 Gallon / 225 liters . . . 960 servings  
 80 Gallon / 300 liters . . . 1280 servings

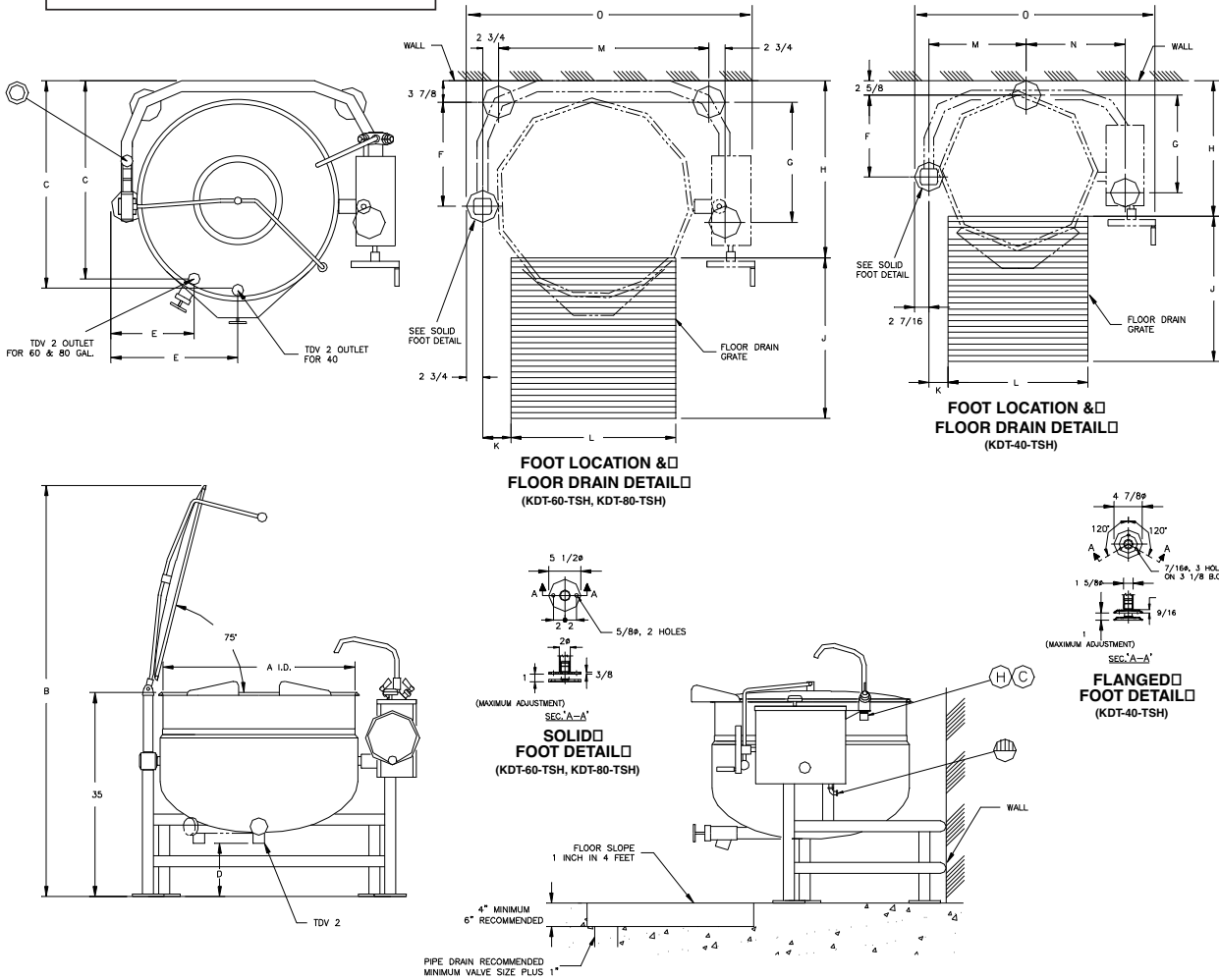

Direct Steam Kettles

**DIMENSIONS**

DWG. NO.	KETTLE	A	B	C	D	E	F	G	H	J	K	L	M	N	O
KE95564-1	KDL-40-TSH	29 1/2	68 1/4	33 3/8	13 1/4	19 5/8	16	18 3/4	26 5/8	28	3 1/4	28	18 1/2	18 3/4	45 1/2
KE95564-2	KDL-60-TSH	33	70 3/4	31 5/8	9 1/2	21 5/8	17 7/8	20 5/8	27 5/8	30	4	30	35 1/4	N/A	48 5/8
KE95564-3	KDL-80-TSH	35 1/2	76 1/4	38	7	13	18 3/4	21 1/2	30 5/8	30	4 1/4	32	37 3/4	N/A	51 1/2

NOTES:  
 1. ALL VERTICAL DIMENSIONS SHOWN ARE MINIMUM. FEET ARE ADJUSTABLE TO 1 INCH MAXIMUM.

**SPECIFICATIONS**

MODEL	STEAM JACKET RATING			DIRECT STEAM	CONDENSATE RETURN	APPROVALS			CLEARANCE:	SHIPPING WEIGHT
	35 PSI	50 PSI	100 PSI			UL	CSA	NSF		
KDL-40-TSH	N/A	STANDARD	OPTIONAL	3/4" NPT	1/2" NPT				RIGHT: 4 INCHES HANDLE CLEARANCE LEFT: 0 INCHES REAR: 0 INCHES	345 Lbs
KDL-60-TSH										405 Lbs
KDL-80-TSH										460 Lbs

**UTILITIES**

- ⊕ STEAM IN - 3/4 NPT
- ⊕ HOT WATER FAUCET 1/2
- ⊕ COLD WATER FAUCET COPPER TUBE
- ⊕ CONDENSATE RETURN - 1/2 NPT

NOTES:  
 Cleveland Range reserves right of design improvement or modification, as warranted.  
 Many regional, state and local codes exist and it is the responsibility of the owner and installer to comply with the codes.  
 Installation of backflow preventers, vacuum breakers and other specific code requirements is the responsibility of the owner and installer.  
 Cleveland Range equipment is built to comply with applicable standards for manufacturers. Included among those approval agencies are U.L., A.G.A., NSF, ASME/N.Bd., CSA, CGA, ETL and others. (NOT TO SCALE)