



AIR AGITATED ICE BUILDER

- MODELS:**
- | | | | |
|----------------------------------|----------------------------------|----------------------------------|-----------------------------------|
| <input type="checkbox"/> IBC-50 | <input type="checkbox"/> IBC-150 | <input type="checkbox"/> IBC-250 | <input type="checkbox"/> IBC-450 |
| <input type="checkbox"/> IBC-75 | <input type="checkbox"/> IBC-175 | <input type="checkbox"/> IBC-300 | <input type="checkbox"/> IBC-500 |
| <input type="checkbox"/> IBC-100 | <input type="checkbox"/> IBC-200 | <input type="checkbox"/> IBC-350 | <input type="checkbox"/> IBC-600 |
| <input type="checkbox"/> IBC-125 | <input type="checkbox"/> IBC-225 | <input type="checkbox"/> IBC-400 | <input type="checkbox"/> IBC-1000 |



Cleveland Standard Features

- Direct expansion ice builder, with externally equalizing thermostatic expansion valves.
- For operation with R-22, 404A or R507 refrigerant (please specify).
- Liquid and suction headers are provided with single point connections to the condensing unit.
- Coils are factory pressure tested, dried using a deep vacuum, and filled with dry nitrogen at atmospheric pressure for shipping.
- For fast, even temperature distribution the water return is located on the rear of the tank and the chilled water outlet on the front.
- Tank is constructed of 1/4" steel plate with angle stiffeners, and all seams are double welded.
- 2" thick insulation between double plated tank bottom.
- Tank sides and ends have a 3" polystyrene insulation between the tank wall and the outer sheathing of stucco embossed aluminum.
- Interior of the tank is coated with a zinc dust primer.
- Standard top 2" insulated covers are sectional, overlapping, and self-draining.
- Air blower with removable air distribution pipes, located between each vertical bank of ice coils, for even ice build-up and melting.
- Automatic ice bank control with temperature and conductivity sensors. Indicates low ice condition.
- Waterproof control box mounted to outside of tank.
- Automatic water level control furnished with 3/4" water solenoid valve.
- Available in sizes for up to 100,000 lbs. capacity.

Options & Accessories

- Ice water control panel for location in production area (model IW-CP).
- Condensing units for indoor or outdoor installation, air or water cooled (specify).
- Water circulating pumps (must be sized by mechanical engineer).
- Pump package stand with premounted water circulation pump and air blower, complete with motor starters.

ITEM NUMBER _____

JOB NAME / NUMBER _____

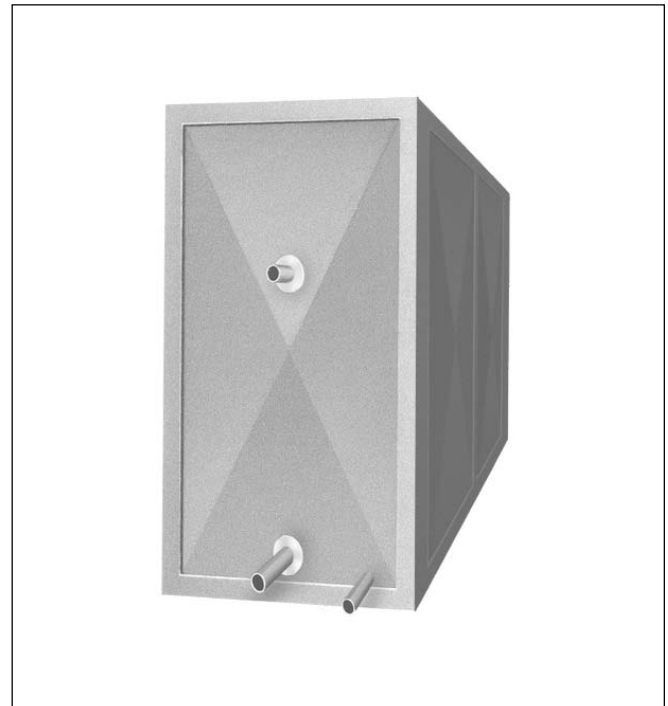

Short Form Specifications

Shall be Cleveland Model IBC-____; _____,000 lbs., capacity air agitated ICE BUILDER for direct expansion operation; thermostatic expansion valves; liquid and suction headers are provided with single point connections to condensing unit. The coils are factory tested, dried using a deep vacuum. Unit includes: Automatic water level control, insulated covers, ice bank control, liquid line solenoid and air agitation package. Tank is constructed of 1/4" steel plate with angle stiffeners, 3" polystyrene insulation on sides and ends, 2" thick insulation on bottom. The exterior is covered by stucco embossed aluminum panels.

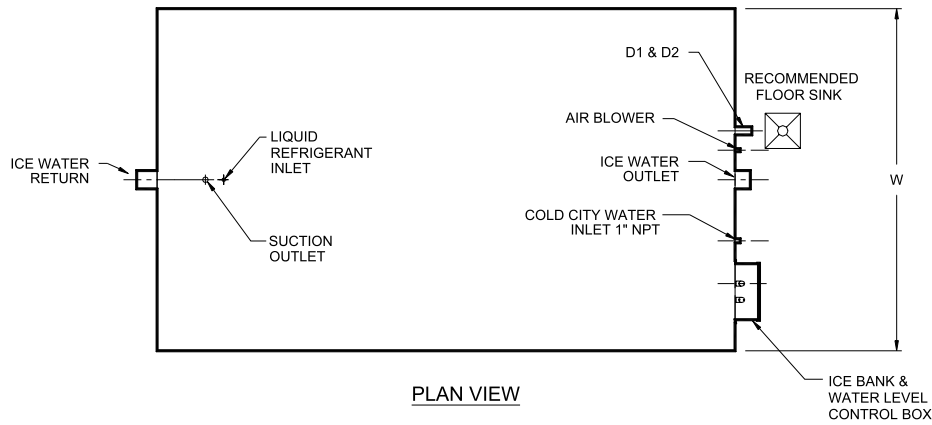

| MINIMUM CLEARANCE | |
|-------------------|-----|
| FRONT | 36" |
| SIDE | 24" |
| REAR | 36" |

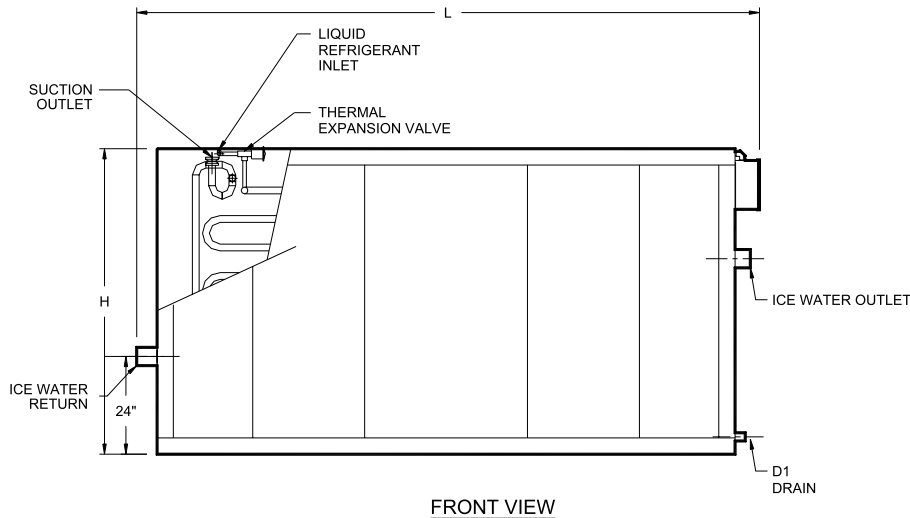

ICE WATER CONNECTIONS

| | |
|--------------------|----|
| IBC-50 to IBC-100 | 3" |
| IBC-125 to IBC-250 | 4" |
| IBC-300 to IBC-500 | 5" |
| IBC-600 | 6" |
| IBC-1000 | 8" |

LIQUID INLET

| | |
|---------------------|------------|
| IBC-50 to IBC-100 | 7/8" |
| IBC-125 to IBC-250 | 1 1/8" |
| IBC-300 to IBC-400 | 1 3/8" |
| IBC-500 | (2) 1 1/8" |
| IBC-600 to IBC-1000 | (2) 1 3/8" |

SUCTION OUTLET

| | |
|---------------------|------------|
| IBC-50 to IBC-75 | 1 3/8" |
| IBC-100 to IBC-175 | 2 1/8" |
| IBC-200 to IBC-250 | 2 5/8" |
| IBC-300 to IBC-450 | 3 1/8" |
| IBC-500 | (2) 2 5/8" |
| IBC-600 to IBC-1000 | (2) 3 1/8" |

AIR BLOWER INLET

| | |
|---------------------|--------|
| IBC-50 to IBC-75 | 3/4" |
| IBC-100 to IBC-200 | 1" |
| IBC-225 to IBC-450 | 1 1/2" |
| IBC-500 to IBC-1000 | 2" |

D2 OVERFLOW

| | |
|--------------------|----|
| IBC-50 to IBC-1000 | 2" |
|--------------------|----|

D1 DRAIN

| | |
|--------------------|----|
| IBC-50 to IBC-1000 | 3" |
|--------------------|----|

DIMENSIONS

| MODEL | ICE STORAGE CAPACITY (LBS) | OVERALL TANK LENGTH L | OVERALL TANK WIDTH W | OVERALL TANK HEIGHT H | TANK WATER CAPACITY (GALS) | AIR BLOWER HP | NO. OF THERMAL EXP. VALVES | SHIPPING WEIGHT (LBS) | OPERATING WEIGHT (LBS) |
|----------|----------------------------|-----------------------|----------------------|-----------------------|----------------------------|---------------|----------------------------|-----------------------|------------------------|
| IBC-50 | 5000 | 107" | 69" | 75" | 1400 | 1/2 | 4 | 4470 | 16260 |
| IBC-75 | 7500 | 122" | 84" | 75" | 2150 | 1/2 | 5 | 5050 | 22900 |
| IBC-100 | 10000 | 153" | 84" | 75" | 2800 | 1 1/2 | 5 | 6500 | 29980 |
| IBC-125 | 12500 | 153" | 84" | 90" | 3150 | 1 1/2 | 5 | 9000 | 35150 |
| IBC-150 | 15000 | 178" | 84" | 90" | 3750 | 1 1/2 | 5 | 10500 | 42100 |
| IBC-175 | 17500 | 173" | 84" | 105" | 4350 | 3 | 5 | 11500 | 47600 |
| IBC-200 | 20000 | 194" | 84" | 105" | 4950 | 3 | 5 | 12750 | 54400 |
| IBC-225 | 22500 | 184" | 98" | 105" | 5550 | 3 | 6 | 13250 | 59300 |
| IBC-250 | 25000 | 201" | 98" | 105" | 6100 | 3 | 6 | 14750 | 66100 |
| IBC-300 | 30000 | 236" | 98" | 105" | 7250 | 3 | 6 | 17250 | 78300 |
| IBC-350 | 35000 | 236" | 113" | 105" | 8450 | 3 | 7 | 19500 | 90700 |
| IBC-400 | 40000 | 206" | 127" | 120" | 9550 | 3 | 8 | 20250 | 100700 |
| IBC-450 | 45000 | 228" | 127" | 120" | 10700 | 3 | 8 | 22500 | 112650 |
| IBC-500 | 50000 | 381" | 98" | 105" | 12100 | 5 | 12 | 28500 | 130400 |
| IBC-600 | 60000 | 339" | 113" | 120" | 14450 | 5 | 14 | 31000 | 152750 |
| IBC-1000 | 100000 | 479" | 127" | 120" | 23500 | 5 | 16 | 48500 | 246500 |

NOTES: LIQUID LINE SOLENOID VALVE, SIGHT GLASS AND AIR BLOWER SHIPPED LOOSE. REFRIGERANT NOT SUPPLIED BY CLEVELAND RANGE.



**CONTINENTAL
EQUIPMENT CORP.**

TEL: (414) 463-0500

FAX: (414) 463-3199

P.O. Box 18662

6103 N. 76th Street

Milwaukee, WI 53218

**CONTINENTAL
SAMPLE ICE BUILDER MANUAL**



**CONTINENTAL
EQUIPMENT CORP.**

LATENT HEAT STORAGE UNITS OR

ICE BUILDERS

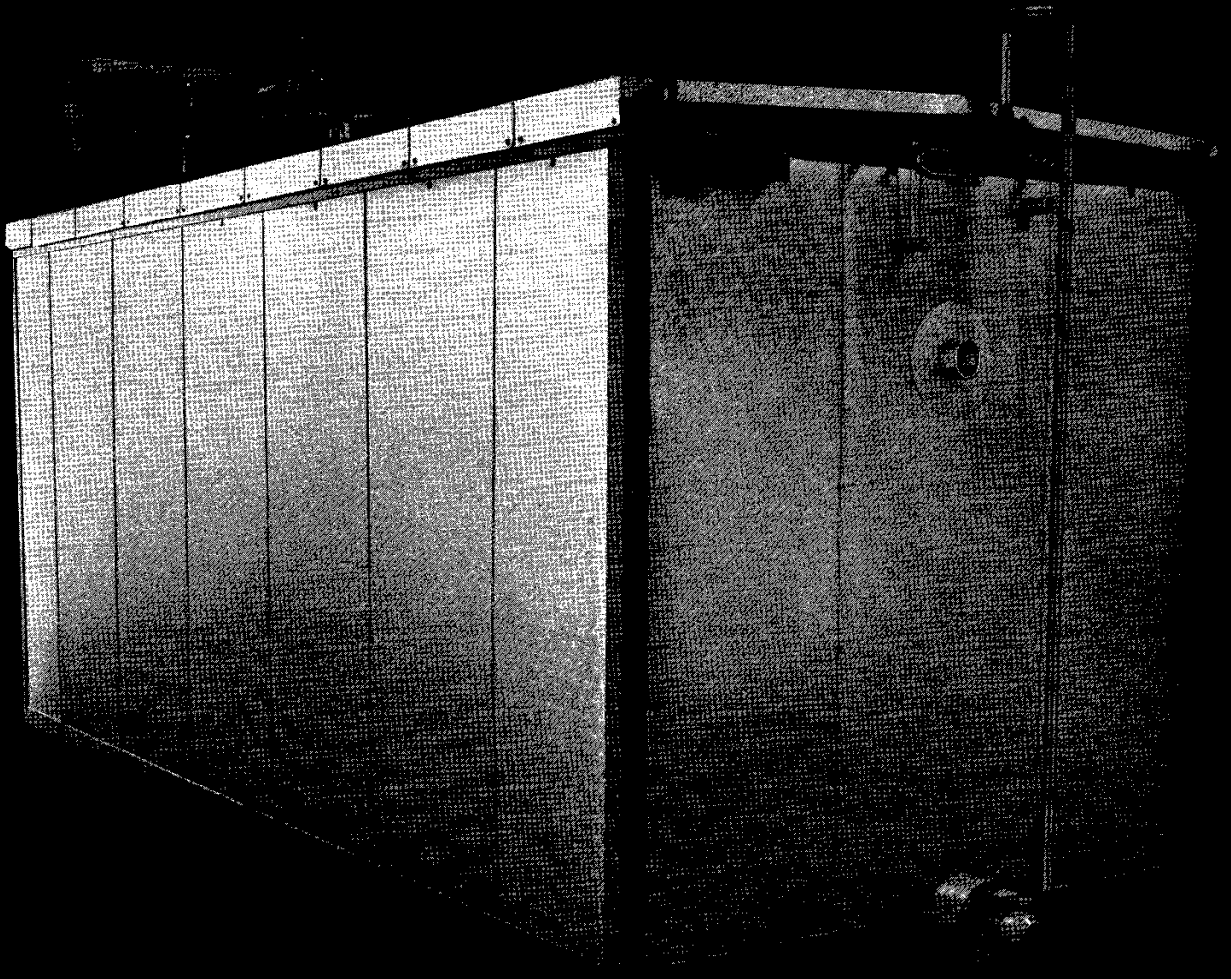

AIR-AGITATED ICE BUILDERS OR LATENT HEAT STORAGE UNITS

Continental latent heat storage units store refrigeration in the form of ice. The latent heat storage resulting from the change in state from water to ice is the key to the success of these units. Large quantities of refrigeration can be stored in a relatively small space. The ice can be produced during periods of low demand for refrigeration or electrical energy. It can then be used at a later time in the form of 32° F to 34° F cooling water. This concept is ideal for leveling out refrigeration loads that are not constant throughout the cooling period and also for high refrigeration loads of relatively short duration. Because refrigeration compressors and related equipment do not have to be sized to meet peak load requirements, very large savings can be realized in the purchase of equipment.

Additional energy savings can be realized by building ice to store refrigeration during times when electrical demand for other uses is low, thus holding down demand charge rates. Many utility companies are also imposing time of day rates with lower rates during periods of low general demand and again ice can be built during these periods to take advantage of the lower rates.

Another advantage of Continental thermal energy storage systems is that working from a reserve, system capacity is not lost should there be a compressor breakdown. Latent heat storage units can have a split evaporator with two compressors separately connected. In this way, if one fails there is another to give at least 50% capacity (more by running it longer) until the failure has been remedied.

For certain heating, ventilating and air conditioning applications, the units can be used for storing both cold and heat. The cold is stored as both latent and sensible heat while the heat is sensible heat only. This is accomplished by using the ice building coil as a condenser instead of an evaporator to heat the water in the tank.

AIR AGITATION

Once the ice has been built on the coils to store the latent heat or thermal energy, it must be melted off evenly to provide as low and even a temperature to the outgoing water as possible. There are many ways of attempting to do this. One has been to chart a definite path through the ice builder with an elaborate system of baffles and by-passes. This is effective to a point, but requires additional pump head and the warmer entering water melts more ice at the entrance end and less at the exit.

As a result, the ice water temperature tends to rise part way through the cooling process. If all of the ice is not melted, it tends to overbuild at the exit and in some cases block the flow of water. This method was improved upon by adding a mechanical agitator to the same maze of baffles to push the water through the charted course at a greater speed. This helped, but the melting problems still prevailed and the idea of reversing the water flow through the tank periodically was initiated which was fine as long as someone didn't forget to reverse the flow.

Continental Equipment started using air for agitation in ice builders over a quarter of a century ago. This meant that the

baffles and by-passes could be eliminated. Low pressure air distribution lines between EACH vertical bank of ice coils at the bottom of the tank, provide complete uniform agitation. Warm water returning at one end of the tank is instantly mixed with the ice water, resulting in a uniform ice melting temperature with no agitation dead spots and resulting ice blocks. Ice water exits at the opposite end of the tank, so the return water must pass through the entire ice bank.

Some imitators have cut corners and do not supply an air agitation line between each vertical bank of ice coils. This results in an uneven pattern of agitation over the tank area with dead spots where unwanted ice build-up can occur.

Continental Equipment supplies a compact, highly efficient, low-pressure air blower for agitation with each ice builder. The air agitation is only needed when the ice is being melted and the air blower motor starter should be interlocked with the ice water circulating pump motor starter. The air agitation lines in Continental ice builders are easily removable for servicing should that be necessary.

Continental Equipment Corp. has hundreds of air-agitated ice builders in use world-wide.

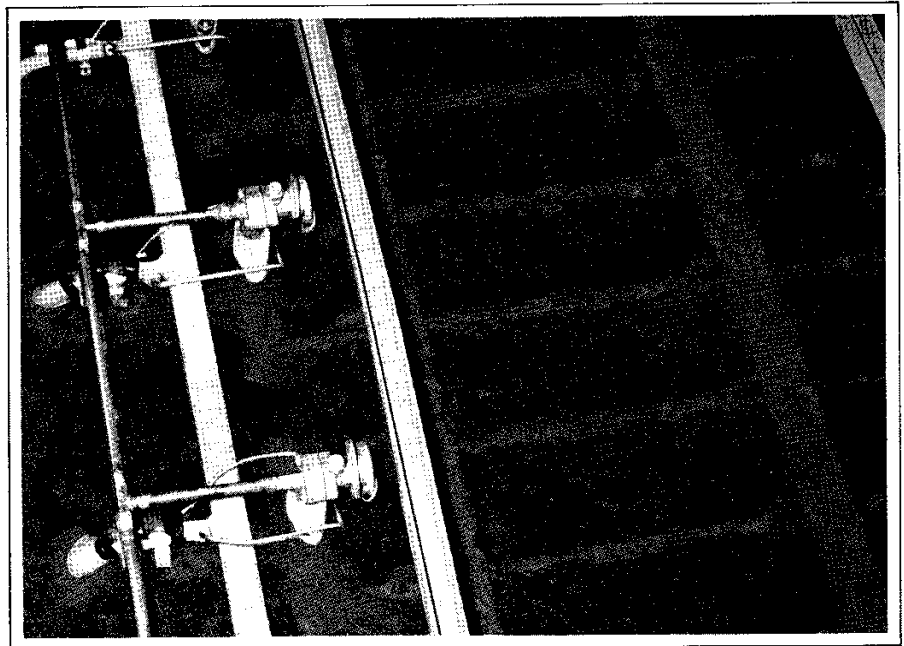

AIR AGITATION IN CONTINENTAL ICE BUILDERS

This view shows a very even pattern of turbulence due to the placement of the air orifices. The agitation is used only when melting ice and an even disbursement is very important to prevent dead spots and unwanted ice build-up from occurring.

FEATURES OF CONTINENTAL AIR-AGITATED ICE BUILDER

- Tanks are constructed from 1/4" thick steel plate. All seams are double welded and tested. Heavy structural stiffeners limit distortion and stress.
- Double plate bottoms have a 2" thickness of molded polystyrene insulation sandwiched between them.
- Tank sides and ends have a 3" thickness of polystyrene insulation between the tank wall and the outer sheathing of stucco embossed aluminum. The insulation is glued to the steel tank wall eliminating condensation problems.
- Standard top covers are formed from a single thickness of stucco embossed aluminum sheet, while the optional insulated top covers have a 2" thickness of molded polystyrene insulation completely encased between aluminum sheets. All top covers are sectional, overlapping, self-draining and are secured to the tank.
- Four lifting and jacking lugs are provided at the bottom of all ice builders. Larger units are also furnished with four top lifting lugs. These are securely welded to the inner tank.
- The water return is located on the rear of the tank and the chilled water outlet on the front. The connections are weld stubs except for 3" size which is threaded. A 1" water make-up, 2" overflow and 3" drain connections are provided on the front of the ice builder. A sight glass is also furnished for easily checking the water level.
- The air inlet has a vacuum breaker to prevent water from getting into the air blower on shut-down. Removable air distribution pipes are located between EACH vertical bank of ice coils for an even pattern of agitation.
- The interior of the tank is coated with a zinc dust primer, as well as all exterior angles and the surge drum.
- All of the pipe coils are bent on 7" centers and are headered on 7 1/4" centers. The coils are made from mill lacquered 1 1/4" Schedule 40 steel pipe.
- Direct-expansion models have every two coil sections headered together and top fed by an externally equalized thermostatic expansion valve. The liquid inlets are located evenly between the coils to prevent over-feeding the coil directly in front of the inlet and starving the other coils, as happens when more than two coils are headered together. The suction risers are sized for a practical gas velocity to return any oil and they draw from the bottom of the headers. These risers are brought in to the top of a common suction header with a single section outlet. This is to prevent the possibility of any liquid in the lines affecting the thermostatic expansion valves' remote control bulbs. The expansion valves are headered together for a single liquid inlet and the risers are headered together for a single suction outlet. The coils have a deep vacuum drawn on them and then they are tested and filled with dry nitrogen for shipping. All direct-expansion models have 8% more pipe coil than required for similar capacity flooded models to compensate for the tapered ice building due to refrigerant superheat. Direct-expansion models under 20'0" long have a single evaporator coil and longer units have double evaporator coils back to back in the tank. This results in a more efficient operation because of shorter gas travel and reduced pressure drop.
- All full-flooded models have the coils headered together with a large liquid leg, built-in oil sump and 3/4" oil purge line through the tank wall. The coil top header has two gas returns which are flanged; together with the liquid leg to the oversized A.S.M.E. surge drum. The surge drums are sized to hold from 40% to 60% of the capacity of the coil evaporator. They are complete with all controls including a float switch, balance lines, solenoid valve and strainer, expansion valve, dual relief valve assembly and suction and liquid hand valves. Full-flooded models under 30'0" long have a single evaporator with the surge drum and controls located at the rear of the tank while longer models have a double coil bank with a common liquid leg and surge drum located at the center of the tank.
- Models for recirculated refrigerant or overfeed flooding have the coils headered together and the individual coils have orifices to assure proper distribution for top feeding the evaporator. The liquid and gas return risers are also properly sized for oil return.
- Straight through water flow from the rear to the front of the tank results in no loss in pumping head. The entering water is quickly dispersed in the tank and is picked up by the air agitation to mix it completely with the contents of the tank. The air agitation causes it to pass over all of the ice banks on its path to the outlet in the front of the tank.
- The water capacity of each tank is approximately twice the amount needed to freeze the rated ice capacity. This is a result of more space between the ice banks and also between the ice banks and the tank walls, thus nearly eliminating any possibility of ice bridging across the coils and of the tanks bulging because of a freeze-up.
- An automatic ice bank control is mounted on all models with the sensors attached to the pipe coils and the relay mounted in a waterproof enclosure located on the outside of the tank.
- An automatic water level control is supplied as an option at additional cost. It constantly maintains the water level in the tank. It has a protected level sensor inside the tank and a relay mounted in a waterproof enclosure located on the outside of the tank. A 1" water solenoid valve is furnished for the water supply line.

YOU CAN NOT BUY BETTER



**CONTINENTAL
EQUIPMENT CORP.**

SPECIFICATIONS SUBJECT TO CHANGE
WITHOUT NOTIFICATION

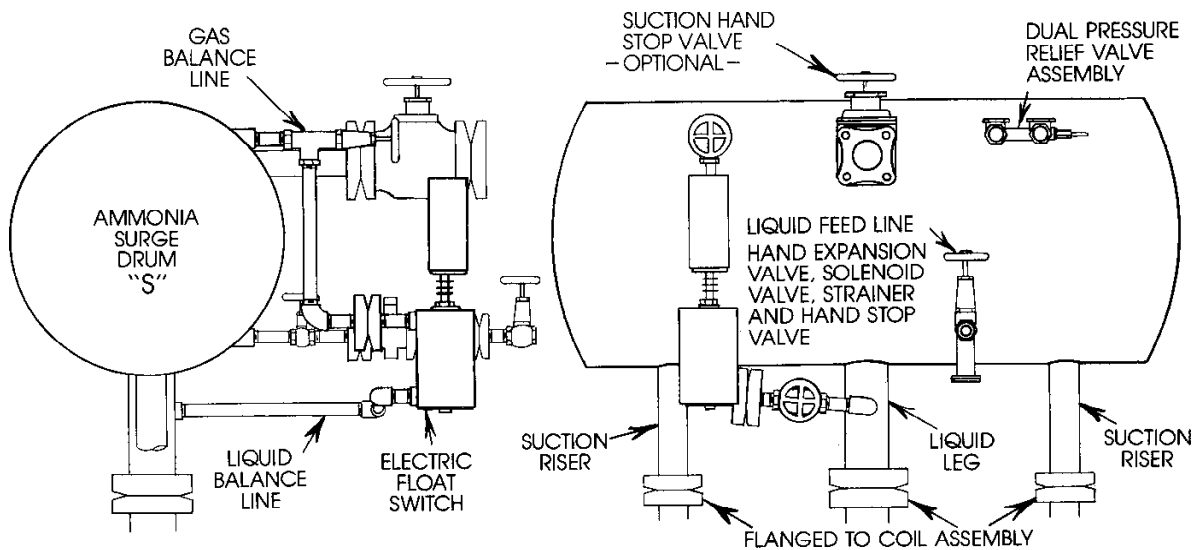

SURGE DRUM AND CONTROLS - FULL-FLOODED AMMONIA MODELS

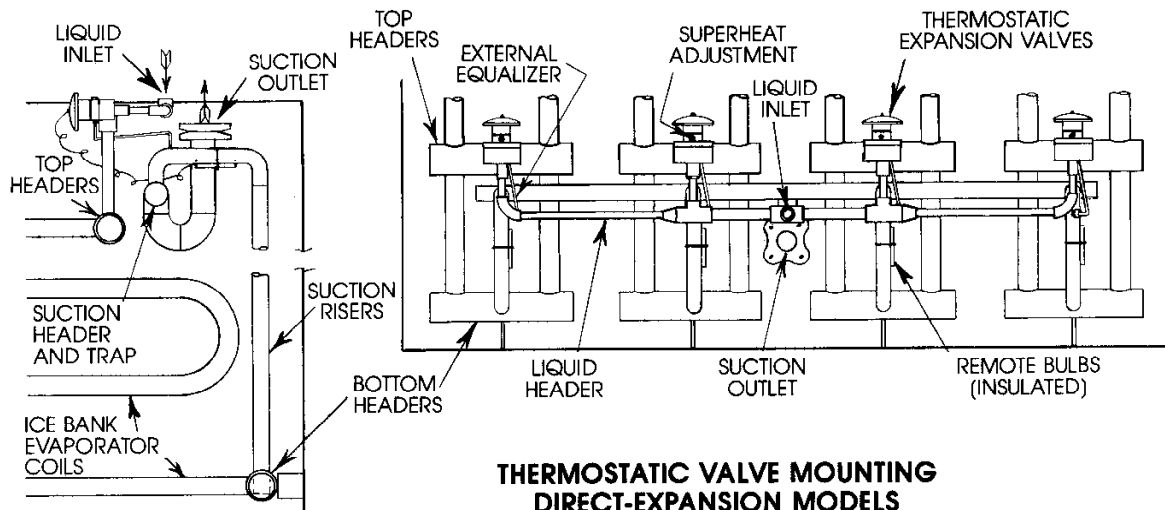

THERMOSTATIC VALVE MOUNTING DIRECT-EXPANSION MODELS

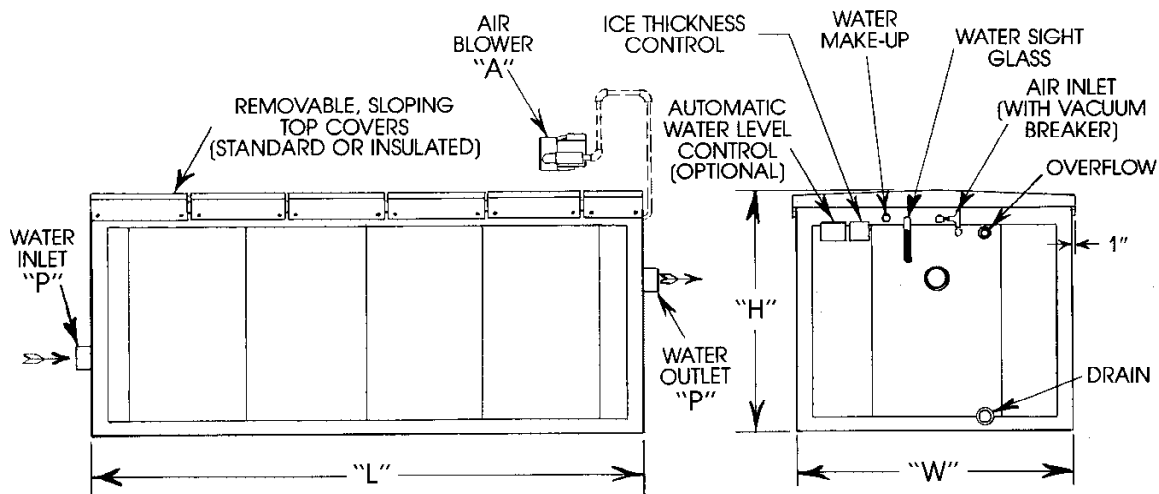

ICE BUILDER SIDE AND END ELEVATION

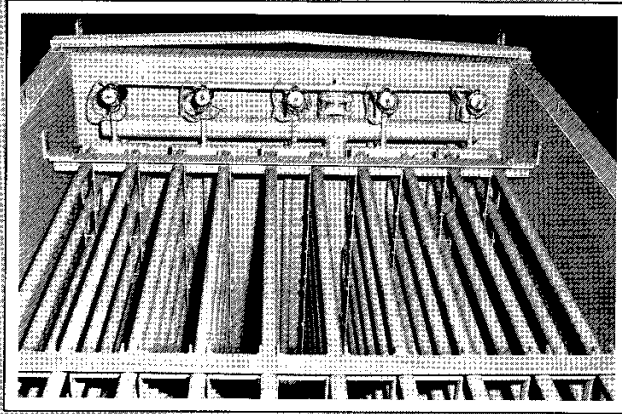

SINGLE BANK DIRECT-EXPANSION MODEL

This view shows the mounting and headering of the thermostatic expansion valves. Only two coil banks are headered to one valve, so there is no danger of over-feeding one coil bank more than the others. The remote bulbs are mounted on a free draining horizontal section of the suction line and are insulated. The suction lines come from the bottom of the suction headers and are properly sized to bring any oil out with the refrigerant gas. A flanged sweat copper suction connection is mounted as well as a sweat copper liquid connection. After drawing a deep vacuum on the coil assembly, it is filled with dry nitrogen for shipping.

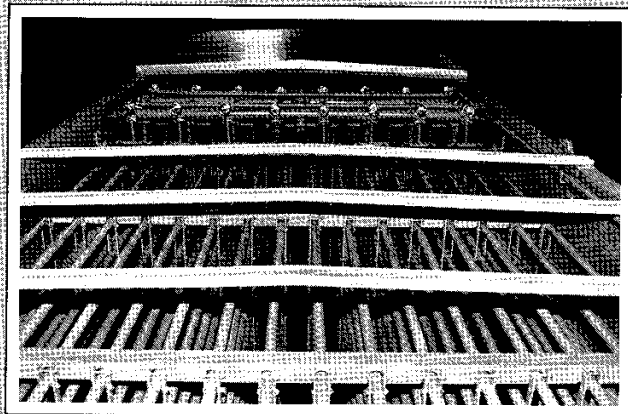

DOUBLE BANK DIRECT-EXPANSION MODEL

This view shows the mounting and headering of the thermostatic expansion valves. These larger ice builders have two separate single bank coil evaporators in one tank. Generally, each evaporator is operated with its own condensing unit. However, the two evaporators could be connected together and operated as one. Shorter coils and shorter gas travel promote faster, more efficient freezing.

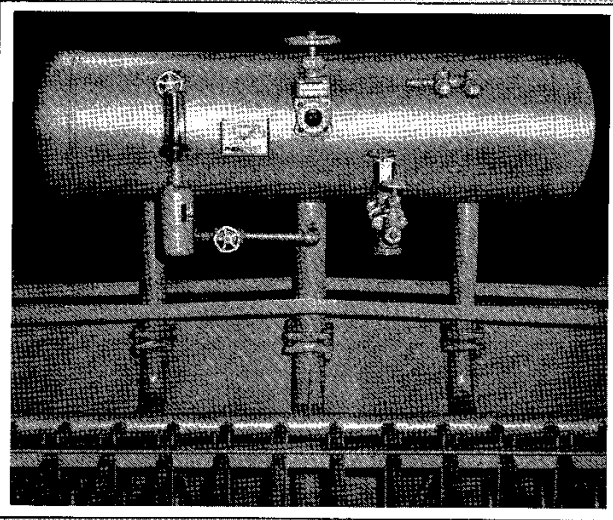

SINGLE BANK FULL-FLOODED MODEL

This view shows the mounting of the A.S.M.E. surge drum flanged to the coil assembly for easier shipping. It shows the float switch mounted, as well as the liquid line with hand expansion valve, solenoid valve strainer and shut-off valve. It also shows the dual pressure relief valve assembly and the optional large suction shut-off valve that is furnished.

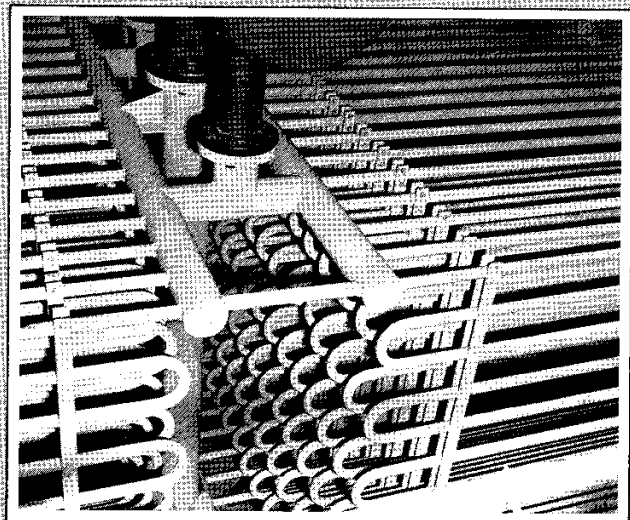

DOUBLE BANK FULL-FLOODED MODEL

This view shows the two large coil banks connected into and fed by a common liquid leg. It also shows the large A.S.M.E. surge drum, flanged to the double coil assembly for easier shipping. All of the same controls that are furnished for the single bank ice builders are furnished for the double bank ice builders. Shorter coils and shorter gas travel promote faster, more efficient freezing.

CONTINENTAL AIR-AGITATED ICE BUILDERS MODELS FOR DIRECT-EXPANSION OPERATION — PHYSICAL DATA

| Model No. | Ice Storage @ 2-1/2" (lbs.) | Cooling Storage (ton hrs.) | Tank Length ("L") | Tank Width ("W") | Tank Height ("H") | Tank Water Capacity (gals.) | Ice Water Connections I.P.S. ("P") | Air Agitator Nominal H.P. ("A") | Lineal Feet Pipe Coil | No. of Thermostatic Expansion Valves | Shipping Weight (lbs.) | Operating Weight (lbs.) |
|------------|-----------------------------|----------------------------|-------------------|------------------|-------------------|-----------------------------|------------------------------------|---------------------------------|-----------------------|--------------------------------------|------------------------|-------------------------|
| 5-8-8E | 5,000 | 60 | 7'11" | 5'9" | 6'3" | 1,400 | 3" | 1/2 | 416 | 4 | 4,470 | 16,260 |
| 10-8-10E | 10,000 | 120 | 11'10" | 7'0" | 6'3" | 2,800 | 3" | 1-1/2 | 831 | 5 | 6,500 | 29,980 |
| 15-8-10E | 15,000 | 180 | 17'0" | 7'0" | 6'3" | 4,200 | 4" | 1-1/2 | 1,246 | 5 | 9,375 | 44,645 |
| 15-10-10E | 15,000 | 180 | 13'11" | 7'0" | 7'6" | 3,750 | 4" | 1-1/2 | 1,246 | 5 | 10,500 | 42,100 |
| 20-10-10E | 20,000 | 240 | 18'0" | 7'0" | 7'6" | 4,950 | 4" | 1-1/2 | 1,661 | 5 | 13,500 | 55,200 |
| 20-12-10E | 20,000 | 240 | 15'3" | 7'0" | 8'9" | 4,950 | 4" | 3 | 1,661 | 5 | 12,750 | 54,400 |
| 25-12-10E | 25,000 | 300 | 18'9" | 7'0" | 8'9" | 6,100 | 4" | 3 | 2,077 | 5 | 15,750 | 67,100 |
| 25-12-12E | 25,000 | 300 | 15'10" | 8'2" | 8'9" | 6,100 | 4" | 3 | 2,077 | 6 | 14,750 | 66,100 |
| 30-12-12E | 30,000 | 360 | 18'9" | 8'2" | 8'9" | 7,250 | 5" | 3 | 2,493 | 6 | 17,250 | 78,300 |
| 35-12-14E | 35,000 | 420 | 18'9" | 9'5" | 8'9" | 8,450 | 5" | 3 | 2,907 | 7 | 19,500 | 90,700 |
| 40-12-16E | 40,000 | 480 | 18'9" | 10'7" | 8'9" | 9,600 | 5" | 3 | 3,323 | 8 | 21,250 | 102,100 |
| 40-14-16E | 40,000 | 480 | 16'3" | 10'7" | 10'0" | 9,550 | 5" | 3 | 3,323 | 8 | 20,250 | 100,700 |
| 45-14-16E | 45,000 | 540 | 18'1" | 10'7" | 10'0" | 10,700 | 5" | 3 | 3,739 | 8 | 22,500 | 112,650 |
| 45-12-24E | 45,000 | 540 | 28'0" | 8'2" | 8'9" | 10,900 | 5" | 3 | 3,739 | 12 | 25,900 | 117,700 |
| 50-12-24E | 50,000 | 600 | 30'10" | 8'2" | 8'9" | 12,100 | 5" | 5 | 4,154 | 12 | 28,500 | 130,400 |
| 55-12-24E | 55,000 | 660 | 33'8" | 8'2" | 8'9" | 13,250 | 6" | 5 | 4,569 | 12 | 31,100 | 142,700 |
| 55-14-24E | 55,000 | 660 | 29'2" | 8'2" | 10'0" | 13,250 | 6" | 5 | 4,569 | 12 | 30,200 | 141,800 |
| 60-14-24E | 60,000 | 720 | 31'8" | 8'2" | 10'0" | 14,400 | 6" | 5 | 4,984 | 12 | 32,750 | 154,100 |
| 60-14-28E | 60,000 | 720 | 27'4" | 9'5" | 10'0" | 14,450 | 6" | 5 | 4,984 | 14 | 31,000 | 152,750 |
| 65-14-24E | 65,000 | 780 | 34'2" | 8'2" | 10'0" | 15,500 | 6" | 5 | 5,400 | 12 | 35,300 | 165,900 |
| 65-14-28E | 65,000 | 780 | 29'6" | 9'5" | 10'0" | 15,650 | 6" | 5 | 5,400 | 14 | 33,500 | 165,350 |
| 70-14-28E | 70,000 | 840 | 31'8" | 9'5" | 10'0" | 16,800 | 6" | 5 | 5,816 | 14 | 36,000 | 177,550 |
| 70-14-32E | 70,000 | 840 | 28'0" | 10'7" | 10'0" | 16,800 | 6" | 5 | 5,816 | 16 | 34,800 | 176,350 |
| 75-14-28E | 75,000 | 900 | 33'8" | 9'5" | 10'0" | 17,900 | 6" | 5 | 6,231 | 14 | 38,200 | 189,000 |
| 75-14-32E | 75,000 | 900 | 29'10" | 10'7" | 10'0" | 17,900 | 6" | 5 | 6,231 | 16 | 37,000 | 187,800 |
| 80-14-32E | 80,000 | 960 | 31'8" | 10'7" | 10'0" | 19,000 | 8" | 5 | 6,646 | 16 | 39,300 | 199,400 |
| 85-14-32E | 85,000 | 1,020 | 33'6" | 10'7" | 10'0" | 20,500 | 8" | 5 | 7,061 | 16 | 41,600 | 214,300 |
| 90-14-32E | 90,000 | 1,080 | 35'4" | 10'7" | 10'0" | 21,300 | 8" | 5 | 7,477 | 16 | 43,900 | 223,350 |
| 95-14-32E | 95,000 | 1,140 | 37'2" | 10'7" | 10'0" | 22,400 | 8" | 5 | 7,893 | 16 | 46,200 | 234,950 |
| 100-14-32E | 100,000 | 1,200 | 39'0" | 10'7" | 10'0" | 23,500 | 8" | 5 | 8,307 | 16 | 48,500 | 246,500 |

Reduce the height dimension ("H") shown in the table by 2" if fully insulated top covers are not ordered. Multiply the ice storage capacities shown @ 2-1/2" thickness by .846 to give the approximate ice capacity @ 2-1/4" thickness and by .705 to give the approximate capacity @ 2" thickness. Special size models to meet particular requirements are available upon request. All specifications are subject to change without prior notification.

CONTINENTAL AIR-AGITATED ICE BUILDERS MODELS FOR FULL-FLOODED OR RECIRCULATED OPERATION — PHYSICAL DATA

| Model No. | Ice Storage @ 2-1/2" (lbs.) | Cooling Storage (ton hrs.) | Tank Length ("L") | Tank Width ("W") | Tank Height ("H") | Tank Water Capacity (gals.) | Ice Water Connections I.P.S. ("P") | Air Agitator Nominal H.P. ("A") | Lineal Feet Pipe Coil | Surge Drum Size Dia. x Length ("S") | Shipping Weight (lbs.) | Operating Weight (lbs.) |
|------------|-----------------------------|----------------------------|-------------------|------------------|-------------------|-----------------------------|------------------------------------|---------------------------------|-----------------------|-------------------------------------|------------------------|-------------------------|
| 10-8-10F | 10,000 | 120 | 11'10" | 7'0" | 6'3" | 2,400 | 3" | 1-1/2 | 769 | 20"x50" | 7,000 | 27,250 |
| 15-10-10F | 15,000 | 180 | 14'0" | 7'0" | 7'6" | 3,825 | 4" | 1-1/2 | 1,154 | 20"x50" | 10,500 | 42,800 |
| 20-10-10F | 20,000 | 240 | 17'10" | 7'0" | 7'6" | 4,925 | 4" | 1-1/2 | 1,538 | 20"x50" | 13,400 | 55,000 |
| 20-12-10F | 20,000 | 240 | 15'3" | 7'0" | 8'9" | 4,950 | 4" | 3 | 1,538 | 20"x50" | 12,750 | 54,550 |
| 25-12-10F | 25,000 | 300 | 18'5" | 7'0" | 8'9" | 6,050 | 4" | 3 | 1,923 | 20"x78" | 15,400 | 66,500 |
| 25-12-12F | 25,000 | 300 | 15'9" | 8'2" | 8'9" | 6,075 | 4" | 3 | 1,923 | 20"x78" | 15,550 | 66,850 |
| 30-12-12F | 30,000 | 360 | 18'5" | 8'2" | 8'9" | 7,150 | 5" | 3 | 2,308 | 20"x78" | 17,000 | 77,400 |
| 35-12-12F | 35,000 | 420 | 21'1" | 8'2" | 8'9" | 8,200 | 5" | 3 | 2,692 | 20"x78" | 19,500 | 88,750 |
| 35-12-14F | 35,000 | 420 | 18'5" | 9'5" | 8'9" | 8,350 | 5" | 3 | 2,692 | 20"x78" | 19,050 | 89,500 |
| 40-12-12F | 40,000 | 480 | 23'9" | 8'2" | 8'9" | 9,300 | 5" | 3 | 3,077 | 20"x78" | 21,950 | 100,500 |
| 40-12-14F | 40,000 | 480 | 20'9" | 9'5" | 8'9" | 9,425 | 5" | 3 | 3,077 | 20"x78" | 21,450 | 101,000 |
| 45-12-12F | 45,000 | 540 | 26'5" | 8'2" | 8'9" | 10,350 | 5" | 3 | 3,462 | 24"x92" | 24,450 | 111,900 |
| 45-12-14F | 45,000 | 540 | 23'0" | 9'5" | 8'9" | 10,475 | 5" | 3 | 3,462 | 24"x92" | 23,800 | 112,300 |
| 50-14-12F | 50,000 | 600 | 25'3" | 8'2" | 10'0" | 11,450 | 5" | 3 | 3,846 | 24"x92" | 26,100 | 122,850 |
| 50-14-14F | 50,000 | 600 | 22'0" | 9'5" | 10'0" | 11,600 | 5" | 3 | 3,846 | 24"x92" | 25,000 | 123,000 |
| 55-14-12F | 55,000 | 660 | 27'7" | 8'2" | 10'0" | 12,500 | 6" | 3 | 4,231 | 24"x92" | 28,500 | 134,100 |
| 55-14-14F | 55,000 | 660 | 24'0" | 9'5" | 10'0" | 12,650 | 6" | 3 | 4,231 | 24"x92" | 27,250 | 134,100 |
| 60-14-12F | 60,000 | 720 | 29'10" | 8'2" | 10'0" | 13,550 | 6" | 5 | 4,615 | 24"x92" | 30,850 | 145,350 |
| 60-14-14F | 60,000 | 720 | 25'11" | 9'5" | 10'0" | 13,700 | 6" | 5 | 4,615 | 24"x92" | 29,400 | 145,200 |
| 65-14-14F | 65,000 | 780 | 27'11" | 9'5" | 10'0" | 14,800 | 6" | 5 | 5,000 | 24"x92" | 31,700 | 156,750 |
| 65-14-16F | 65,000 | 780 | 24'9" | 10'7" | 10'0" | 14,800 | 6" | 5 | 5,000 | 24"x92" | 30,750 | 155,800 |
| 70-14-14F | 70,000 | 840 | 29'10" | 9'5" | 10'0" | 15,800 | 6" | 5 | 5,385 | 24"x92" | 33,850 | 167,400 |
| 70-14-16F | 70,000 | 840 | 26'5" | 10'7" | 10'0" | 15,800 | 6" | 5 | 5,385 | 24"x92" | 32,800 | 166,350 |
| 75-14-16F | 75,000 | 900 | 28'2" | 10'7" | 10'0" | 16,900 | 6" | 5 | 5,769 | 30"x92" | 35,000 | 177,800 |
| 80-14-16F | 80,000 | 960 | 29'10" | 10'7" | 10'0" | 17,900 | 6" | 5 | 6,154 | 30"x92" | 37,000 | 188,300 |
| 85-14-32F | 85,000 | 1,020 | 32'0" | 10'7" | 10'0" | 19,250 | 8" | 5 | 6,538 | 30"x92" | 39,750 | 202,400 |
| 90-14-32F | 90,000 | 1,080 | 33'8" | 10'7" | 10'0" | 20,300 | 8" | 5 | 6,923 | 30"x92" | 41,800 | 213,350 |
| 95-14-32F | 95,000 | 1,140 | 35'6" | 10'7" | 10'0" | 21,400 | 8" | 5 | 7,308 | 30"x92" | 44,100 | 225,000 |
| 100-14-32F | 100,000 | 1,200 | 37'2" | 10'7" | 10'0" | 22,450 | 8" | 5 | 7,692 | 30"x92" | 46,200 | 236,000 |
| 105-14-32F | 105,000 | 1,260 | 38'10" | 10'7" | 10'0" | 23,450 | 8" | 5 | 8,077 | 30"x92" | 48,200 | 246,400 |

Reduce the height dimension ("H") shown in the table by 2" if fully insulated top covers are not ordered. Add to the height dimension ("H") shown in the table 2'9" for 20" diameter surge drums, 3'3" for 24" diameter surge drums, and 3'6" for 30" diameter surge drums, to give the overall installed height of the surge drum. Multiply the ice storage capacities shown @ 2-1/2" thickness by .846 to give the approximate ice capacity @ 2-1/4" thickness, and by .705 to give the approximate ice capacity @ 2" thickness. Special size models to meet particular requirements are available upon request. All specifications are subject to change without prior notification.

- 1 lb. of ice @ 32°F = 144 B.T.U.'s
- 1 ton-hour of refrigeration = 83-1/3 lbs. of ice
- Approximately 7 lbs. of ice is required to cool 1,000 lbs. of product, with a specific heat of 1, through a range of 1°F.

For detailed information regarding ice freezing and ice melting, as well as refrigerant evaporation rates, ask for Continental Ice Builder Engineering Sheets.

RECOMMENDED SPARE PARTS LIST
CLEVELAND RANGE ICE BUILDERS

- 1 AIR BLOWER REPAIR KIT (INCLUDES VANES)
- 1 SET OF AIR BLOWER DRIVE BELTS
- 1 ICE THICKNESS CONTROL
- 1 LIQUID REFRIGERANT SOLENOID VALVE
- 1 WATER LEVEL CONTROL VALVE
- 1 SIGHT GLASS
- 1 THERMAL EXPANSION VALVE
- 1 WATER PUMP SEAL REPAIR KIT
- 1 WATER LEVEL CONTROL RELAY

K:\FRM\IB\RECPARTS.CRI

INSTALLATION & OPERATING INSTRUCTIONS
CONTINENTAL EQUIPMENT AIR-AGITATED ICE BUILDERS
DIRECT-EXPANSION FREON OPERATION

INSPECTION & UNPACKING

On receipt, inspect your Continental Equipment air-agitated ice builder for any visible damage that may have occurred in shipment. Report any damage immediately to the carrier and file a claim. After inspection, the tank may be rolled by using the rollers under the tank, or raised/lowered by using the lifting and jacking lugs at the bottom 4 (four) corners of the tank. When lifting, be sure that cables do not damage the top covers. Remove the (2) two end top covers before attaching cables to the lifting lugs. The ice builder should be placed in a level position, either on a concrete slab or with supports under the tank. If supports are run crossways of the tank, they should be no more than 3-4 feet apart. If run the length of the tank, they should be no more than 2-2½ feet apart.

Under the top covers, strapped to the coils are boxes containing the water sight glass, water solenoid valve (if ordered) and an envelope of installation and operating instructions. The air blower is also boxed inside the ice builder. The sectional aluminum top covers are fastened to the ice builder tank at each end with (2) two capscrews and are usually shipped in place. Single thickness aluminum, uninsulated top covers are removed for shipment to prevent wind damage in transit.

After the tank is in position, remove the (2) two top covers near the rear of the tank and remove the boxes that are strapped to the coils. The thermostatic expansion valves with remote bulbs and external equalizers are completely mounted together with common liquid and suction refrigerant mains as show in the enclosed installation drawing. These valves are located under the covers at the rear of the ice builder on single coil models. On double coil models, these valves are located back to back in (2) two separate evaporators at the middle of the ice builder, rather than at the end.

CONDENSING UNIT & RELATED EQUIPMENT

The condensing unit capacity required to build a full bank of ice in a given time can be calculated as follows:

$$\text{Condensing unit} = \frac{\text{Ice capacity (Lbs)} \times 144}{\text{Capacity (tons)} \quad \text{Rebuild time (hrs)} \times 12,000}$$

The condensing unit must have this capacity rating at the average suction temperature. This temperature is normally around 10°F for a typical installation.

The condensing unit must be selected to match the refrigerant (R-12, R-22, R-502) for which the ice builder was designed. The differences being in the thermostatic expansion valves and the sizing of the suction risers for oil return. The condensing unit should be equipped with an oil separator, a crankcase heater, dual pressure controls and an oversized receiver. The receiver should be able to hold the complete charge of refrigerant on shut-down.

We recommend the installation of an oil separator between the compressor and the condenser to keep as much oil as possible from passing over into the evaporator. We very strongly recommend the installation of a suction line accumulator to prevent slop-over of liquid refrigerant and oil and consequent slugging in the compressor. Accumulators in larger systems should have a means of removing the liquid from the accumulator such as a liquid transfer pump or electric heater. A liquid suction heat exchanger may be installed for a more efficient operation as the result of lowering the superheat.

REFRIGERATION PIPING

The evaporator coils in the tank have had a deep vacuum drawn on them at the factory down to at least 500 microns. After being held for at least 12 hours to test for leaks, the vacuum was broken and the coils filled with dry nitrogen for shipping. Connect the refrigerant suction line from the connection on the ice builder to the suction side of the compressor by running it through the suction line accumulator and the liquid-suction heat exchanger, if one is used. Most compressors have a strainer built into the suction inlet. To be on the safe side, it might be well to install a good suction line strainer.

Connect the liquid refrigerant line from the condensing unit receiver to the liquid refrigerant main connection on the ice builder by using a line size compatible with the ice builder connections. A liquid solenoid valve should be installed in the line and wired so that it is operated by the ice bank control; closing when a full bank of ice has been built and opening as the ice melts away from the sensor. A liquid strainer and a removable cartridge type dryer should be installed in this line as well as a combination liquid sight glass and moisture indicator.

The system is now ready for testing and charging. A good vacuum should be drawn on the system before charging. After charging, check the refrigerant sight glass to make sure that there are no bubbles indicating that more refrigerant needs to be added. Also, check the color to make sure that the refrigerant is dry. If it is not dry, replace the core in the dryer after a couple of hours of operation. We also recommend that the oil level and condition be checked right after installation and again a few days later. Due to the possibility of foreign matter getting into the system during manufacture, we suggest that the suction line strainer be cleaned, and the oil in the compressor crankcase changed, after a couple of weeks of operation.

ICE THICKNESS CONTROL

The ice thickness control is usually mounted at the front of the ice builder tank in a waterproof enclosure and the sensor is mounted on one of the pipe coils inside the tank. The purpose of the control is to open and close the liquid line solenoid valve which in turn causes the compressor motor to start or stop by means of the pressure switch in order to maintain an ice bank of desired thickness. This control should be wired into the line feeding the liquid line solenoid valve. When ice builds over the sensor, the control closes the solenoid valve, and the compressor pumps the refrigerant out of the coil evaporator and into the liquid receiver. When the coils are pumped out, the compressor is shut off by means of the low pressure switch. When the ice melts away and exposes the sensors, the ice bank control relay opens the solenoid valve which lets liquid into the coil evaporator and causes the pressure switch to start-up the compressor again. The only adjustment of this control is in the location of the sensor. If too much ice is formed, move the sensor closer to the pipe coil evaporator. Not enough ice formed, move the sensor farther away from the pipe coil.

AIR BLOWER

The air blower or air compressor supplied with your ice builder to provide air for agitation may be mounted in any convenient location within a reasonable distance of the ice builder. If at all practical, we recommend locating the air blower at least 2 ft. above the air inlet to the tank. If this is not practical, run the air inlet pipe at least 2 ft. above the water level before dropping it down to the air blower. It is only necessary to pipe from the air blower outlet to the air inlet with a vacuum breaker located at the high point of the piping. Mount the vacuum breaker (a horizontal swing check valve furnished with the ice builder) in a horizontal run of pipe, leaving one end open to atmosphere and the arrow pointing toward the pressurized pipe. This valve is held closed by air pressure during operation and opens when the blower shuts off to prevent water siphoning back. Use the pipe size indicated by the connections. The air blower should run at all times when the ice water pump is running and it is a good idea to interlock the two. It is not necessary to run the air blower during the ice freezing cycle.

Remove the belts and turn the blower by hand to make sure it is free to turn. If the blower has been in storage for more than 2 months during installation, disassemble it and remove and oil the rotor and sliding vanes. If this is not done both the rotor and vanes will be damaged on start-up. Start the motor and check rotation before reconnecting the belts. See enclosed information for the air blower.

WATER PIPING

Next, the water piping should be installed. The large nipple located at the front center of the tank about 2 ft. down from the top is the ice water outlet to the ice water circulating pump and should be connected to the suction side of the pump. It is advisable to install a valve in the suction line so that the pump can be dismantled without draining the water in the tank down to the ice water outlet level. It is advisable to install a throttling valve in the discharge side of the ice water pump, so that the flow of water to the secondary cooling equipment may be regulated. Most secondary cooler manufacturers specify the flow and head required for ice water through their equipment. Less than the required amount will result in inadequate cooling. More than the required amount usually causes no problems and the cooling may be somewhat improved. The warmed return water from the secondary cooler should be piped to the large nipple located at the rear center of the tank about 2 ft. up from the bottom.

The ice builder has a 3" drain located at the lower right front. A valve should be installed in the drain line for easy draining of the tank. Located near the top, directly above the drain connection is an overflow connection, which should be piped to the drain. Located at the top left front is the tank make-up water connection which should be piped to a fresh water supply with a shut-off valve located near the tank. As optional equipment, an automatic water level control can be mounted. This feature constantly maintains the water level in the tank. It consists of a protected water level sensor located inside the tank, a relay located in a waterproof enclosure on the front of the tank and wired to the sensor. A 1" electric solenoid valve shipped loose should be mounted on the make-up water line and wired to the relay.

Unpack the glass liquid level sight gauge and install it in the ½" tapped connections provided near the top left center on the front of the tank. This will enable the operator to determine the water level in the tank at a glance. If the ice builder is to be installed outdoors, we recommend leaving the sight glass off and plugging the openings with ½" pipe plugs. The water in the glass will freeze and break the glass during severe cold weather.

START-UP & ADJUSTMENT

The ice builder is now ready to be filled with water. After the tank has been filled to the level of overflow, the ice builder is ready to start the freezing operation. On the initial start-up with warmer water in the tank and no ice on the coils, relatively high suction pressures will be encountered. Because of this, it may be necessary to regulate the suction hand stop valve at the compressor to keep the suction pressure low enough, so as not to overload the compressor until the pressure levels out to an acceptable range. It is advisable to install an outlet pressure or crankcase pressure regulating valve to protect the compressor motor.

The thermostatic expansion valves are all externally equalized and they are equipped with an external superheat adjustment. After the ice starts to form on the coils, adjust the superheat setting for each valve as low as possible without danger of liquid slugging back to the compressor. After the ice bank is approximately half built, again adjust the valves so that the coil banks all build at approximately the same rate. The superheat adjusting stem is turned clockwise to increase the superheat and counter-clockwise to decrease it. Each full turn represents approximately ½°F of superheat. The ice builder has been designed with 8% additional coil evaporator to compensate for the taper effect of the ice build-up at the suction end of the coil evaporator as a result of the superheat.

Observe the ice builder closely as the ice approaches its' maximum thickness on the pipe coils during the initial start-up to determine whether the ice thickness control sensor is located properly. If the control closes the liquid solenoid valve and shuts off the compressor on low pressure after pump-down before enough ice is formed on the coil, the sensor should be moved slightly farther away from the pipe coil. If the reverse is true, it should be moved slightly toward the pipe coil.

WATER TREATMENT

Ice builder water must be chemically treated to prevent:

1. Corrosion of mild steel surfaces
2. Biological growth
3. Settling of insoluble solids

Molybdates appear to be effective in preventing corrosion at a concentration of 40-60 PPM. Polyacrylates at 3-5 PPM keep solid particles in suspension. Isothiazolinone and brominated propionamide at below 2 PPM work well as biocides. Side stream filtration can be used to remove suspended materials.

Continental Equipment Corp. does not sell or recommend water treatment chemicals. Please contact a water treatment chemical professional to analyze your water and recommend appropriate products. Do this as soon as the machine is installed. Problems are much easier to prevent, than they are to correct.

Your ice builder is now ready for fully automatic operation. With a very minimum of maintenance, your ice builder should give you many years of trouble free operation.

For technical support, please call (414)463-0500 Ext 11.

KATCHMROINSTALL.IBE

08/16/96

OPERATING INSTRUCTIONS

ALL MODELS

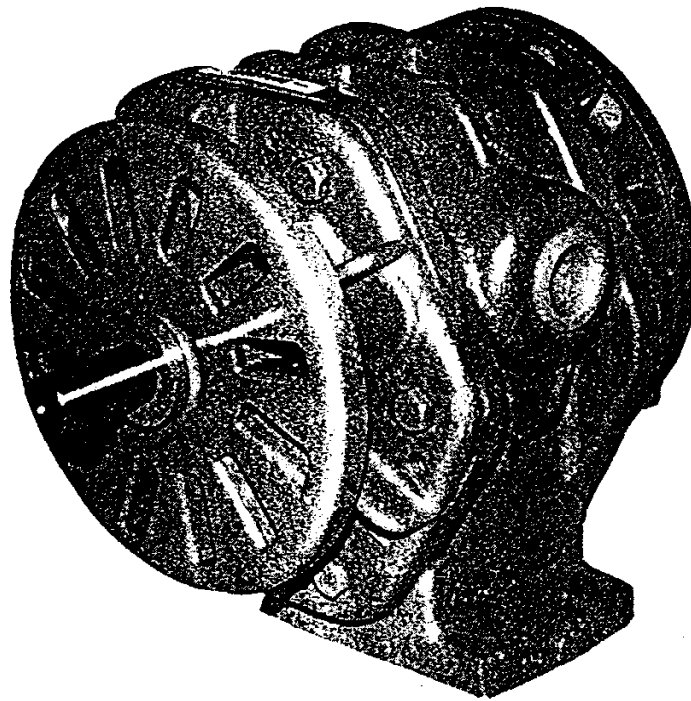

ROTARY VANE POSITIVE DISPLACEMENT
DRY-AIR PUMPS
VAPOR-OIL PUMPS

MADE IN AMERICA SINCE 1939

IMPORTANT

READ BEFORE INSTALLATION OF THIS UNIT

WIRING

All wiring for the installation of this unit should be done by a licensed electrician according to National and Local Electrical Regulations.

SINGLE PHASE MOTOR UNITS

All single phase motors are wired for proper direction of rotation. Unless otherwise requested motors are wired for low voltage service.

• 3-PHASE MOTOR UNITS

The belts have been removed from the unit to avoid running the air pump backwards in case of improper wiring. Wire the 3-Phase motor to rotate in the same direction as the arrow on the Air Pump. **RUNNING THE AIR PUMP BACKWARDS MAY CAUSE VANE BREAKAGE.**

VAPOR OIL PUMPS

Use a High Detergent 10W-40 Oil for all Conde Vapor Oil Pumps. When starting new Vapor Oil Pumps fill oil reservoir above the fittings in which the wicks are inserted. This will give the Pump extra oil for the first two hours of operation.

When refilling fill to just below oil wicks.

Capacities:

| | |
|--------------------|----------|
| Model 2 | 1 quart |
| Model 3 | 1 quart |
| Model 6 | 2 quarts |
| Model 12 | 4 quarts |

AIR PUMP UNIT

ASSEMBLY INSTRUCTIONS

All pipe thread fittings should be coated with a commercial pipe joint compound before assembly.

PRESSURE APPLICATION

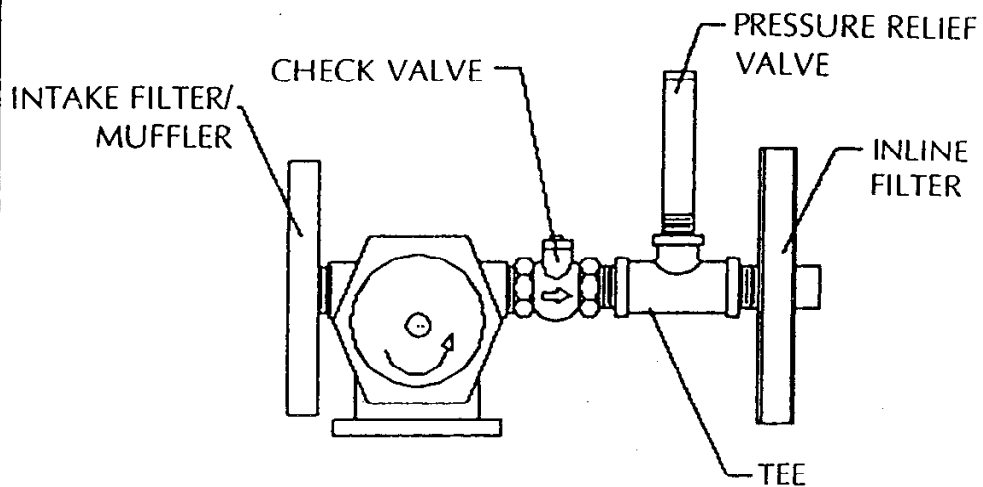

VACUUM APPLICATION

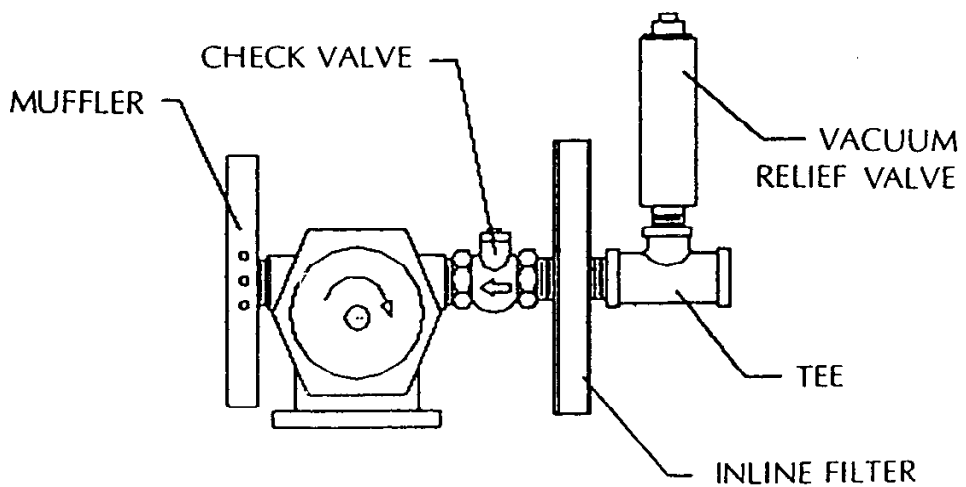

FLUSHING INSTRUCTIONS for CONDE VAPOR OIL PUMPS

It may be necessary to flush your Conde Vapor Oil Pump to remove any gum or varnish buildup inside the pump that cause the vanes to stick in their slots. This is a simple maintenance operation and should be the first step when troubleshooting a loss of vacuum in a system.

1. Remove the oil tube at the oil reservoir.
2. Be sure the exhaust is directed away from the motor or engine.
3. Use kerosene or dry cleaning fluid for flushing process. While the pump is running under vacuum, simply insert the tube into the cleaning fluid and allow the pump to draw the fluid in. Alternately let air into the tube with the cleaning fluid. It can take up to a gallon of cleaning fluid to clean the pump.
4. In the same manner draw in about 5 ounces of oil to complete the flushing process.

ASSEMBLY

1. Before assembly deburr all parts with a fine file. Determine correct rotor rotation (see drawing). Check the vane slots for free movement of vanes.
2. On model 2 Pumps start assembly with side of housing that has the dowel pin holes on the left side of the housing. On model 3, 6 & 12 start on side with dowel pin holes on the right. Note: dowel pin holes are always on the exhaust side of the pump.
On oil lubricated pumps press the shaft seal in place and place the paper gasket in position on the housing. Install the endplate with the six hex screws and finger tighten. Drive the 2 dowel pins in place then tighten hex screws securely.
3. Insert rotor into housing according to rotor rotation and rotation arrows on the pump. (The pump must be assembled in the same position it was disassembled. The rotation cannot be changed.) Assemble the air pump in a vertical position. This will align the rotor with the endplates and housing.
4. Install the slinger over shaft. (green disk)
5. Press bearing on the shaft using a bearing installation tool or arbor press. **IMPORTANT** -press on the inner race of bearing only. Pressing on the plastic seal may cause damage to roller bearings.
6. Invert pump assembly and install the vanes into the slots.
7. Install 2nd endplate as previously done but do not tighten screws and leave dowel pins out. Install bearing and slinger.
8. Apply downward pressure to rotor shaft so that the rotor bottoms out on the 1st endplate, while pressure is applied tighten hex screws evenly. Drive in dowel pins.
9. Shim the pump and install new bearing covers.

IMPORTANT — The pump should spin freely by hand when completed, if any binding is noticed repeat step 9.

10. Install cooling fans.



LIMITED AMBIENT AIR ONLY WARRANTY STANDARD DRY AIR OR VAPOR-OIL AIR PUMPS

Westmoor Ltd. warrants for a period of one (1) year from date of manufacture against defects in workmanship and material. During the period, Westmoor, Ltd. will repair or replace any defective part free of charge, providing the product is returned, shipping prepaid, to our factory. Due to the extreme diversity of uses of the air pump, Westmoor, Ltd. reserves the right to refuse warranty claims if, in the opinion of Westmoor, Ltd., the installation or use of the pump exceeded the design capabilities. The pump is designed for ambient air intake only. Westmoor Ltd. does not warrant against minor leaks not affecting performance.

Owners responsibility include providing normal maintenance as required by Westmoor Ltd. This warranty does not apply (1) if the pump has been damaged due to improper use, neglect, accident, misuse, exposure to extremities of dryness or humidity (2) if the pump has been serviced or modified by other than Westmoor, Ltd. authorized personnel.

No other warranty, expressed or implied, is given. The repair or replacement of the pump is your exclusive remedy. Any implied warranty of merchantability or fitness is limited to the duration of this written warranty. In no event shall Westmoor, Ltd. be liable for consequential or incidental damages. Some states do not allow the exclusion or limitations of this warranty so the above exclusions or limitations may not apply to you. This warranty gives you specific legal rights, and you may have other rights which vary from state to state.

| | | | |
|------|-------------|------|----------|
| REV. | DESCRIPTION | DATE | APPROVED |
| | | | |

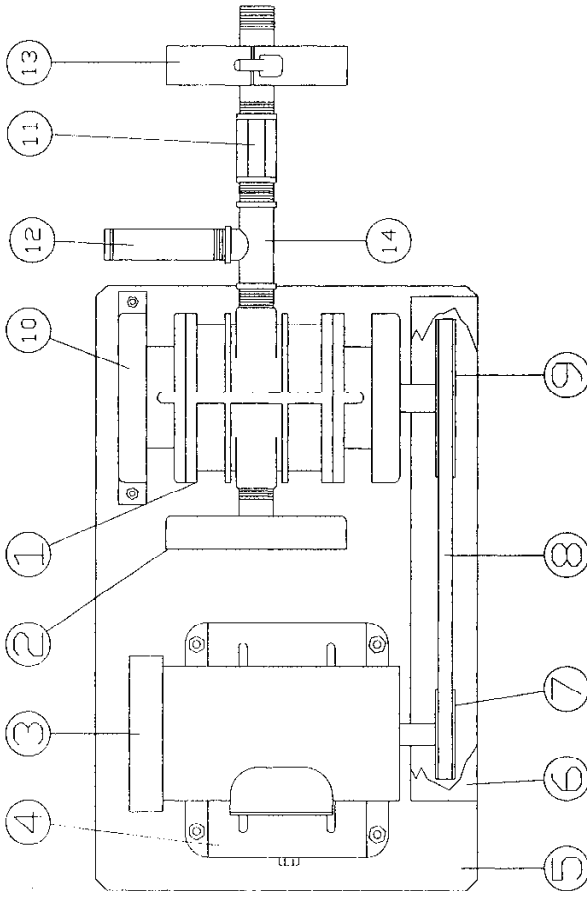

ASSEMBLY NO. DAUNG6949

| ITEM | PART NO. | DESCRIPTION |
|------|------------|--------------------------|
| 1 | DA06CCW00 | MODEL 6 CCW DA PUMP |
| 2 | FLTNR06 | INTAKE FILTER |
| 3 | MT1.5D | 1.5 HP - 3 PH TEFC MOTOR |
| 4 | BASEM145 | MOTOR BASE |
| 5 | BASE06B | PUMP BASE |
| 6 | GRDB06 | BELT GUARD |
| 7 | PULBK3478 | MOTOR PULLEY |
| 8 | BLTB38 | POWER BELT |
| 9 | PULBK571 | PUMP PULLEY |
| 10 | GRDF3612 | FAN GUARD |
| 11 | PFCVSL100 | SPRING -QAD CHECK VALVE |
| 12 | RVP02 | RELIEF VALVE |
| 13 | FLT106 | INLINE FILTER |
| 14 | PFTB101014 | 1 X 1 X 1-1/4 TEE |

NOTE:

SEE DRAWING #XB-710 FOR PREFERRED PIPING ARRANGEMENT

| | | | |
|---|------------|---------------------|-----------|
| ITEM NO. / REV'D | MATERIAL | DESCRIPTION | SHEET NO. |
| CONTINENTAL EQUIPMENT CORP. MILWAUKEE, WI USA | | | |
| SCALE | FILE NO. | -NAME- | -NUMBER- |
| DRAWN BY | DESIGNED | ICE BUILDER | XC-696 |
| DATE | CHECKED | AIR BLOWER ASSEMBLY | |
| 10-15-97 | APPROVED | 1 1/2 HP. | |
| LAST REVISION | PRINT DATE | SHEETS | SHEET NO. |
| | | 1 | 1-C |

2

3

2

3

4

| | | | |
|------|-------------|------|----------|
| REV. | DESCRIPTION | DATE | APPROVED |
| | | | |

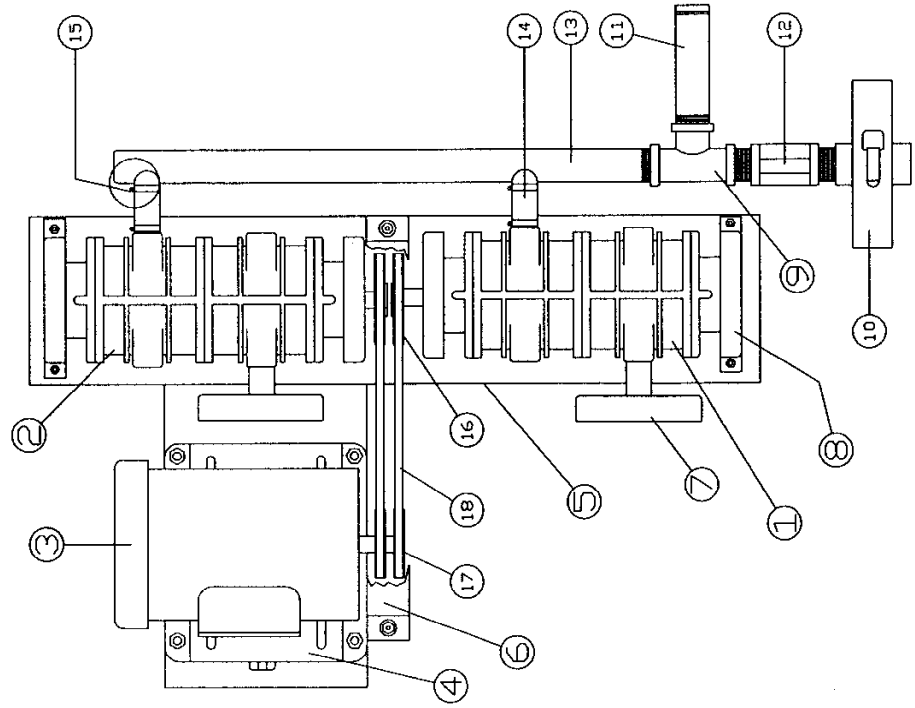

ASSEMBLY NO. - DAUN121298

| ITEM | PART NO. | DESCRIPTION |
|------|------------|-------------------------|
| 1 | DA12CV00 | MODEL 12 CW DA PUMP |
| 2 | DA12CC00 | MODEL 12 CCW DA PUMP |
| 3 | MT5D | 5 HP - 3PH TEFC MOTOR |
| 4 | BASEM182T | MOTOR BASE |
| 5 | BASE12T | PUMP BASE |
| 6 | GRDBT12 | BELT GUARD |
| 7 | FLTRN12 | INTAKE FILTER |
| 8 | GRDF3612 | FAN GUARD |
| 9 | PFTB202020 | 2" TEE |
| 10 | FLTR12A | INLINE FILTER |
| 11 | RVPO3 | RELIEF VALVE |
| 12 | PFCVSL200 | SPRING LOAD CHECK VALVE |
| 13 | MANFT12 | MANIFOLD |
| 14 | HOSEC158 | RUBBER COUPLING |
| 15 | CLAMP036 | STAINLESS STEEL CLAMP |
| 16 | PULBK571 | PUMP PULLEY |
| 17 | PULBK34118 | MOTOR PULLEY |
| 18 | BLTB42 | POWER BELT |

NOTE:

SEE DRAWING #XB-710 FOR PREFERRED PIPING ARRANGEMENT.

| | | | |
|----------|----------|-------------|-----------|
| ITEM NO. | MATERIAL | DESCRIPTION | SHEET NO. |
| | | | |

| | | |
|---|--|--------------------------|
| CONTINENTAL EQUIPMENT CORP. MILWAUKEE, WI USA | | -NUMBER- XC-698 |
| FILE CODE BESTOW ORDER | ICE BUILDER AIR BLOWER ASSEMBLY 5 HP | |
| SCALE --- DTL 10-15-97 | PRINT DATE | SHEETS 1 SHEET NO 1-C |

2

3

2

3

4

1

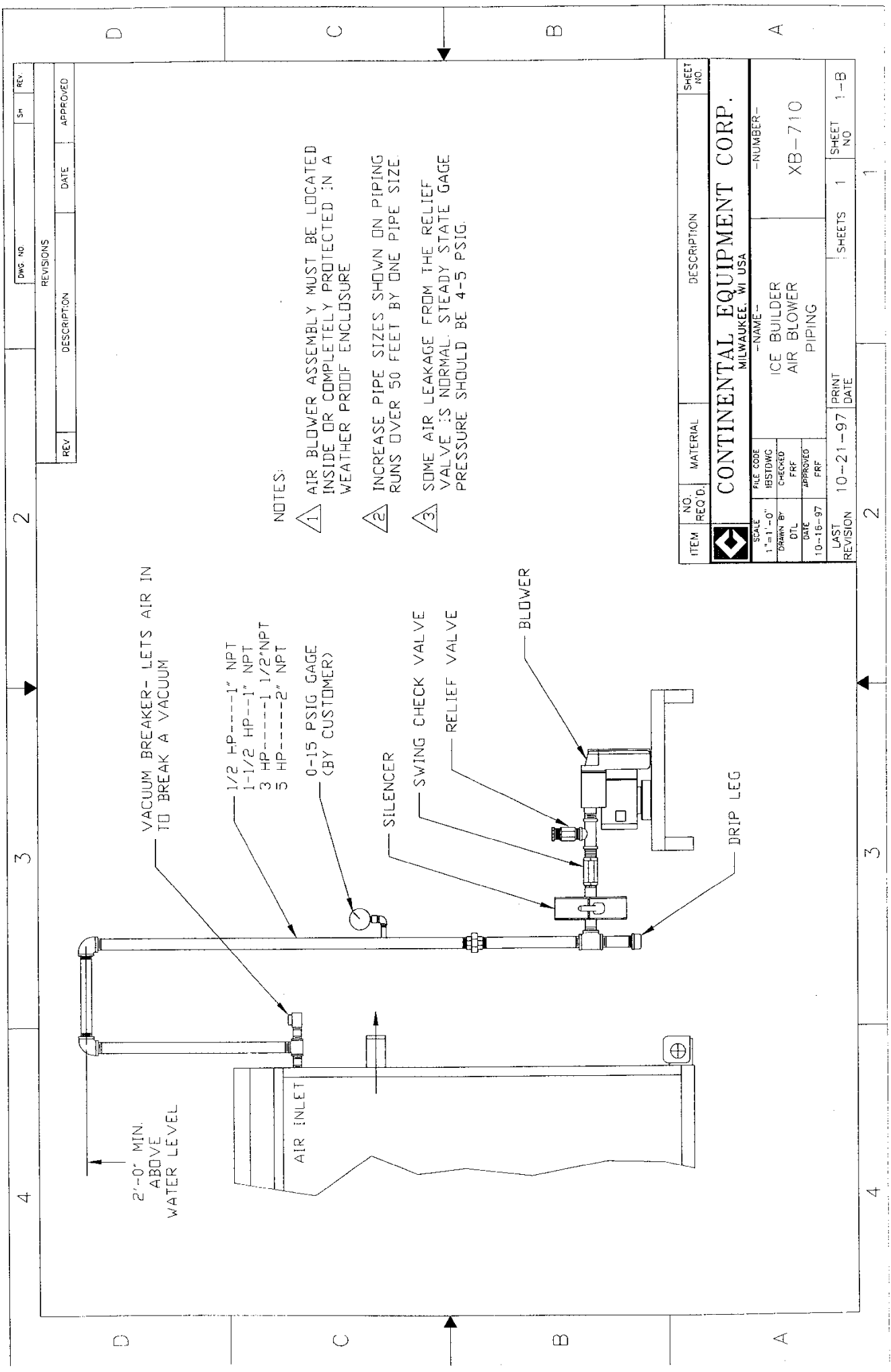

| REV | DESCRIPTION | DATE | APPROVED |
|-----|-------------|------|----------|
| | | | |

| DWG NO. | REV. |
|---------|------|
| | |

NOTES:

- 1 AIR BLOWER ASSEMBLY MUST BE LOCATED INSIDE OR COMPLETELY PROTECTED IN A WEATHER PROOF ENCLOSURE
- 2 INCREASE PIPE SIZES SHOWN ON PIPING RUNS OVER 50 FEET BY ONE PIPE SIZE.
- 3 SOME AIR LEAKAGE FROM THE RELIEF VALVE IS NORMAL. STEADY STATE GAGE PRESSURE SHOULD BE 4-5 PSIG.

| ITEM NO. | REQ'D. | MATERIAL | DESCRIPTION | SHEET NO. |
|--|--------|----------|---|--------------------------|
| CONTINENTAL EQUIPMENT CORP. MILWAUKEE, WI USA | | | | |
| FILE CODE 1" = 1'-0" DRAWN BY DTL DATE 10-16-97 | | | --NAME-- ICE BUILDER AIR BLOWER PIPING | --NUMBER-- XB-710 |
| LAST REVISION 10-21-97 | | | PRINT DATE | SHEETS 1 SHEET NO 1-B |

2

3

4

D

C

B

A

D

C

B

A

2

3

4

1

A

2

2

3

4

4

| | | | |
|-----|-------------|------|----------|
| REV | DESCRIPTION | DATE | APPROVED |
| | | | |

| | | |
|----------|----|------|
| DWG. NO. | SH | REV. |
| | | |

REVISIONS

D

C

B

A

D

C

B

A

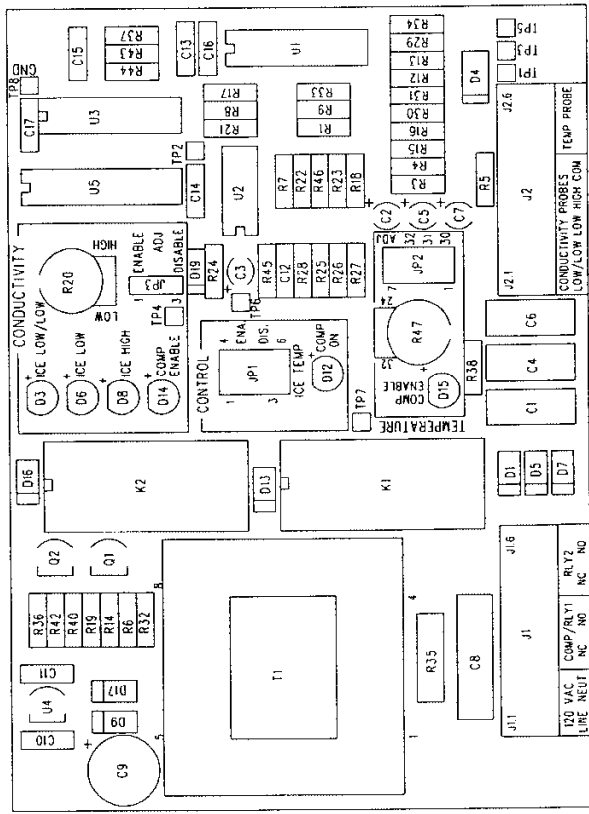

- NOTES:
1. PLACE SHUNT ON PINS 2 AND 3 OF JP3. (DISABLE CONDUCTIVITY ADJUSTMENT).
 2. PLACE SHUNT ON PINS 3 AND 4 OF JP2. (31°F TEMPERATURE).
 3. PLACE SHUNT ON PINS 1 AND 2 OF JP1. (ENABLE CONDUCTIVITY CONTROL).
 4. PLACE SHUNT ON PINS 4 AND 5 OF JP1. (ENABLE TEMP CONTROL).

| | | | | |
|---------------|------------|------------|--|-----------|
| ITEM | NO. REQ'D. | MATERIAL | DESCRIPTION | SHEET NO. |
| | | | CONTINENTAL EQUIPMENT CORP. MILWAUKEE, WI USA | |
| SCALE | FILE CODE | -NAME- | | -NUMBER- |
| FULL | IBSTODDING | ICE BANK | | |
| DRAWN BY | CHECKED | CONTROLLER | | |
| RFA | APPROVED | ASSEMBLY | | |
| DATE | DATE | | | |
| 08-27-97 | 08-22-97 | | | |
| LAST REVISION | 08-22-97 | PRINT DATE | SHEETS | SHEET NO |
| | | | 1 | 1-B |

2

3

4

4

OPERATING INSTRUCTIONS ICE BANK CONTROL 08/29/97

A. PRINTED CIRCUIT BOARD DRAWING

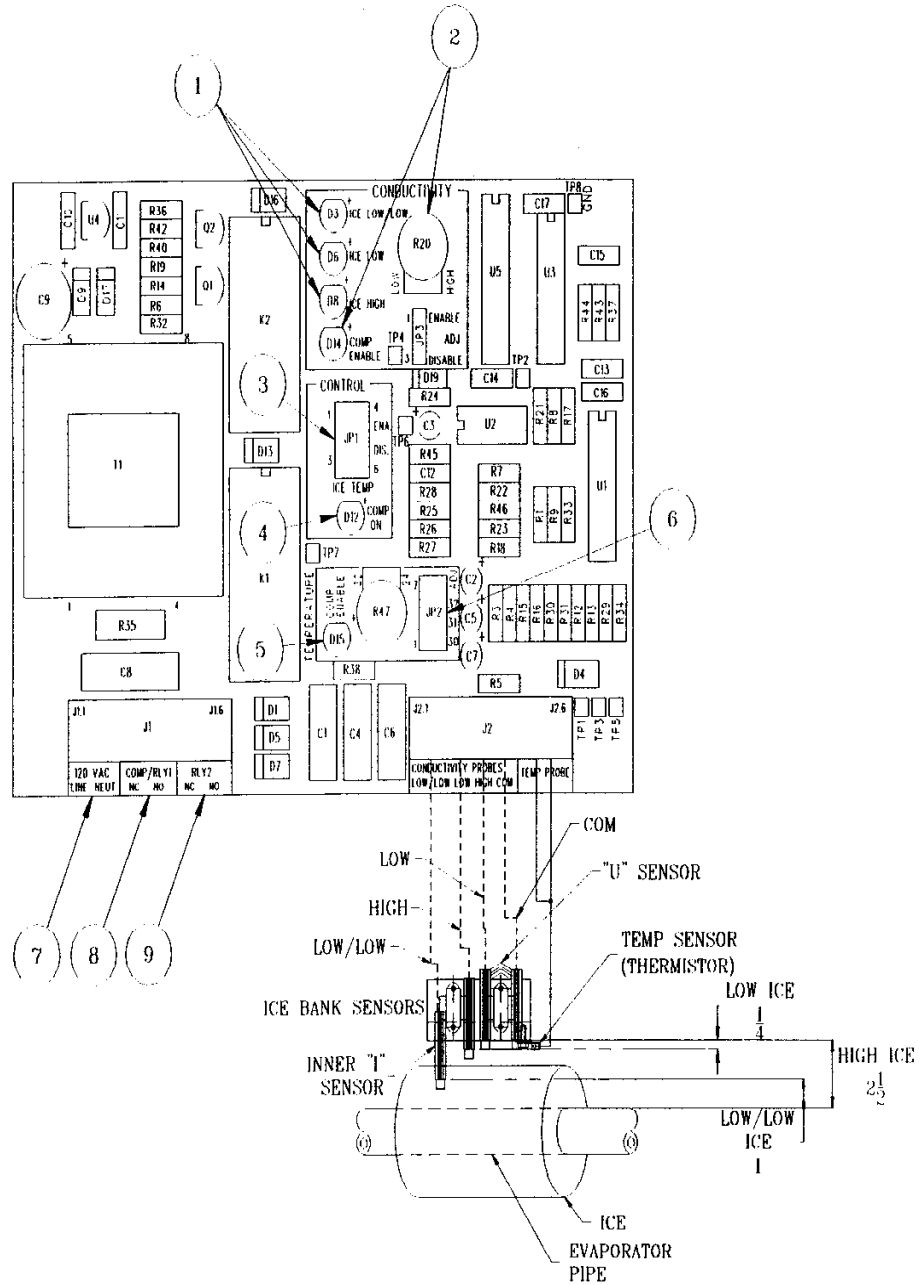

Item 1

"ICE HIGH" light (green) indicates that ice has built to its maximum thickness, as set by the distance from the evaporator coil to the tips of the "U" shaped sensor. When ice builds outward covering the tips of the "U" sensor, the "ICE HIGH" light turns on, relay K1 drops out and the "COMP ENABLE" (compressor enable) light goes out. The "NO" (normally open) contact on relay K1 opens, usually closing a normally closed, liquid line solenoid valve and eventually turning off the compressor through a low pressure switch. The ice must melt back to uncover both the "U" sensor and the outer "I" sensor, before relay K1 pulls in and the "COMP ENABLE" light (red) turns on again. The distance between the "U" sensor and the outer "I" sensor sets the differential ice thickness (factory set at 1/4"). The "HIGH ICE" light turns off as soon as the "U" sensor is exposed to water.

The "U" sensor can be adjusted to a maximum thickness of 2 1/2" (the factory setting). Adjusting the sensor for a lesser ice thickness will reduce storage capacity, but allows operation at higher, more efficient evaporating temperatures.

"ICE LOW" light (green) indicates that the ice has built to a thickness set by the distance from the evaporator coil to the tip of the outer (farther from the evaporator coil) "I" sensor. During the melting cycle, ice melts back to the outer "I" sensor, before relay K1 pulls in and turns on the "COMP ENABLE" light.

"ICE LOW/LOW" light (green) indicates a low ice condition, as set by the distance from the evaporator coil to the tip of the inner (closer to the evaporator coil) "I" sensor. The inner "I" sensor is factory set at an ice thickness of 1". Relay K2 drops out when this probe is covered with ice. A remote low ice light can be wired to the NO (normally open) contact of relay K2. This probe is an optional feature.

Item 2

"COMP ENABLE" light indicates that the control has enabled compressor operation based on conductivity. If the light does not turn off, even though the sensors are encased in ice, set the jumper JP3 to the enable position. Rotate potentiometer R20 fully clockwise to begin with and then slowly clockwise until the light goes out.

Item 3

"JP1" jumpers are used to set the desired mode of operation. The control can cycle the refrigeration system based on the difference in conductivity between ice and water or the difference in temperature between ice and water or both (the factory setting). Place jumpers in the enable or disable positions. If glycol is added to the water to depress the freezing point or if the water is dirty, set the control to operate based on temperature only.

Item 4

"COMP ON" light (red) indicates that the control is requesting that the compressor be turned on to form more ice. If both the conductivity and temperature modes of operation are enabled, both "COMP ENABLE" lights must be on before the "COMP ON" light will turn on. If only one mode of operation is selected, then the respective "COMP ENABLE" light must be lit.

Item 5

"COMP ENABLE" light indicates that the control has enabled compressor operation based on temperature.

Item 6

"JP2" allows selection of a higher or lower set-point for temperature operation. The factory setting is 31°F. If the "COMP ENABLE" light turns off, before the temperature sensor is covered with ice, move the jumper to a lower setting (setting for 30°F is available). Sensor accuracy is plus or minus 1°F. If Glycol is added to the water to depress the freezing point, set the jumper to the adjustable setting. This allows a setpoint range of 24°F-32°F by turning the potentiometer just to the left of the jumper. Rotate clockwise for a lower setting and counterclockwise for a higher setting.

Item 7

"J1 120 VAC". Connect the 120 volt, 60 hertz, single phase alternating current power source to these terminals. The hot lead (L1) should be connected to "LINE" terminal and the neutral lead (L2) should be connected to the "NEUT" terminal.

Item 8

"J1 COMP/RLY1". Connect a 120 volt, 60 hertz, single phase, alternating current, liquid line solenoid valve to the NO terminal. A contact between the "line" terminal and the "COMP/RLY 1 NO" terminal closes, when more ice is required. The NC terminal may be used for a remote 120 volt, 60 hertz, single phase alternating current light to indicate "Ice Bank Full". Maximum continuous inductive load 50 VA. Maximum inrush 250 VA.

Item 9

"J1 RLY2". The NO terminal may be used for a remote a 120 volt, 60 hertz, single phase alternating current light to indicate a "low ice" condition. A contact between the "line" terminal and the "COMP/RLY 2 NO" terminal closes, when ice melts back to uncover the inner "I" probe and relay K2 pulls in. Maximum continuous inductive load 50 VA. Maximum inrush 250 VA.



Take-Apart Series Thermo® Valves Installation Instructions & Service Data (TCL, TER, TIR, THR, TJL & TJR)

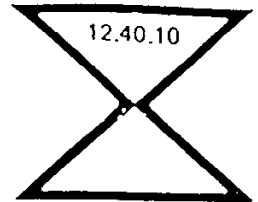

MARCH 1979
Sup'ds Nov. 1978

General Information

1. The all-purpose take-apart series valves are ideal for use on all types of air conditioning, commercial refrigeration and low temperature applications with evaporator temperature ranges of +50°F to -50°F.
2. The "T" series valves have three component parts: Power Assembly, Cage Assembly and Flange. There are no working parts in the flange. It is never necessary to break the line connections to service the valve.

Safety Instructions

1. Read Installation Instructions thoroughly. Failure to follow Instructions may result in valve failure, system damage or personal injury.
2. Do not use on service conditions or fluids not specifically cataloged, without prior approval of Alco Engineering Department. Use of Thermo valves on applications not specifically cataloged can result in valve failure and/or system damage.
3. Protect against excessive vibration as it may result in a bulb tubing break which will cause valve malfunction or failure.
4. Foreign matter in the Thermo valve may cause diaphragm failure, flooding, or starving. Use of an EK Filter Drier is strongly recommended.
5. Valves are factory set to a specific superheat. If adjustment is needed, refer to Instructions for proper procedure. Improper adjustment may result in system damage.
6. Be sure valve is installed so that its flow arrow corresponds to flow direction through piping.
7. On valves with solder connections remove the power assembly, cage assembly and gaskets prior to brazing.
8. Use back up wrench on all wrench flats. Overtorquing may result in valve body damage.
9. Proper valve sizing is important. An oversized valve may result in erratic control. An undersized may considerably reduce system capacity.
10. Do not exceed Safe Working Pressure of 450 PSIG, as excess internal pressure could cause damage to diaphragm resulting in valve malfunction.
11. Do not exceed safe working temperature of 300° as excess temperatures could cause internal damage resulting in improper valve function.

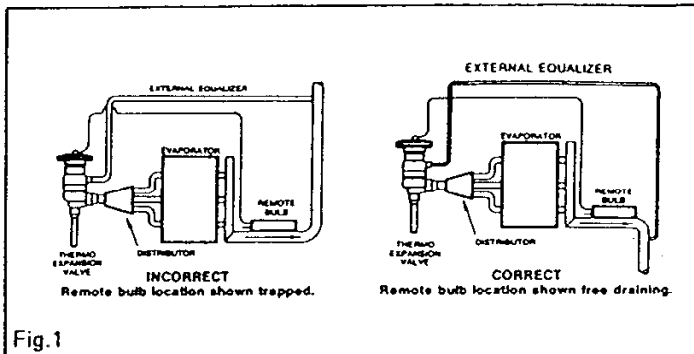

Fig. 1

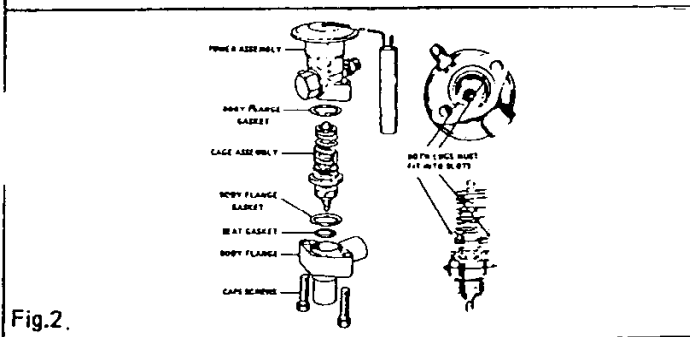

Fig. 2.

SERVICE INSTRUCTIONS

To inspect, clean or replace parts of valves:

1. Disconnect equalizer line.
2. Remove the cap screws.
3. Carefully lift off the power assembly.
4. Remove cage assembly and gaskets.
5. Assemble in same order as disassembled.
6. When putting the power assembly on make sure the cage assembly lugs line up with the slots inside the power assembly (See Fig. 2).
7. Tighten cap screws evenly and torque to 300 inch pounds.
8. Check for leaks.

SUPERHEAT ADJUSTMENT

Alco Thermo Valves are factory set for the static superheat settings listed below, unless orders specify otherwise.

Table 1.

| FACTORY SUPERHEAT SETTINGS | | | | | |
|----------------------------|----------------|--------------------|----------------|--------------------|----------------|
| R22 | | R12 | | R502 | |
| REFRIGERANT CHARGE | SUPERHEAT CODE | REFRIGERANT CHARGE | SUPERHEAT CODE | REFRIGERANT CHARGE | SUPERHEAT CODE |
| FW, FW55 | 6A | HW, HW100 | 6A | RW, RW110 | 6A |
| FW35 | 6A | HW80 | 6A | RW65 | 6A |
| FW15 | 10C | HW35 | 10C | RW35 | 10C |

Superheat code explanation-Numerical indicates static superheat in degrees F. Letter indicates bulb bath temperature. (A=32° F, C=0° F).

To adjust valve to other superheat settings:

1. Remove seal cap on side of valve.
2. Turn the Adjusting Stem clockwise to increase the superheat and counter clockwise to decrease the superheat. (Approximately 1/2° F per turn.)
3. Reinstall Seal Cap.

Installation Instructions

1. **WARNING:** Before opening any system, make sure the pressure in the system is brought to and remains at atmospheric pressure. Failure to comply may result in system damage and/or personal injury.
2. Valves may be installed in any position, but should be located as close as possible to the distributor or evaporator inlet. Refer to roughing - in dimensions for valve dimensions.
3. Be sure valve is installed so its flow arrow corresponds to flow direction through the piping.
4. Install line connections to valve. On valves with solder connections, remove the power assembly, cage assembly and gaskets prior to brazing. Use back up wrench on all wrench flats.
5. When reassembling valve follow the service instructions. Tighten cap screws to torque specification.
6. Attach the remote bulb to the suction line as close to the evaporator as possible in a horizontal run and position the bulb at the 4 or 8 o'clock position. Clean the surface of the suction line where the remote bulb is to be attached then securely fasten the bulb.
7. Connect one end of external equalizer line to the valve. Connect the other end to the suction line slightly downstream from the remote bulb location and positioned so that it cannot siphon oil from the suction line. See Figure 1.
8. Check for leaks, sufficient system refrigerant and be sure no flash gas is present.

| VALVE NOMENCLATURE | | | | | | |
|--------------------|--|--------------------------|--|---|--|----------------|
| TCL | E | B | 2 | H | W | 100 |
| Valve Type | External Equalizer (Omit for Internal Equalizer) | Bleed Hole (optional) | Capacity (tons) 2 - New Style 200 - Old Style | System Refrigerant F - R12 H - R22 R - 502 | Charge & Bulb W - Standard WS - Rapid Response (Optional) | MOP (Optional) |

PRESSURE EQUALIZATION BLEED HOLES FOR SYSTEM

When a permanent split-capacitor motor is used to drive a refrigeration compressor, it is necessary to provide some means of equalizing the high and low side pressures during the "off" cycle so that the motor can start with minimum torque.

ALCO "T" Series valves, with come-apart construction, can be furnished with a bleed hole in the body flange, which allows system pressures to equalize on the "off" cycle. These are the only valves presently manufactured that insure proper bleed in the system even though standard power assemblies or standard cage assemblies are changed or replaced.

The letter "B" is used after the valve series number to denote a valve with bleed hole construction. For example: TCLBFW. The body flange is stamped with the letter "B" followed by the bleed hole diameter, Example: B036, and a small pressure sensitive label is affixed to each body flange. This label is illustrated below.

SELECTING PROPER BLEED HOLE SIZE

The required bleed hole size for a particular system is a function of the high side and low side volumes, the pressure difference across the valve at time of shut-down, the equalization time required and quantity of refrigerant charge. Due to the many variables, each application must be tested to determine the correct size required. It should be remembered that bleed hole size adds to the total effective port area of the Thermo valve and may affect cage size selection.

Table 3 - should be used as a guide in selecting bleed hole sizes, but final selection should not be made without thorough testing.



Table 3
SINGLE OUTLET "T" SERIES BODY FLANGES WITH BLEED HOLE

| VALVE TYPE NUMBER | | | BLEED HOLE DIAMETER FOR % CAPACITY BY-PASS | | | | | | | | | | | |
|-------------------|-----------|-----------|--|------------|----------|------------|----------|------------|----------|------------|----------|------------|----------|------------|
| R-12 | R-22 | R-502 | 10% | | 15% | | 20% | | 25% | | 30% | | 40% | |
| | | | Dia. In. | Drill Size | Dia. In. | Drill Size | Dia. In. | Drill Size | Dia. In. | Drill Size | Dia. In. | Drill Size | Dia. In. | Drill Size |
| TCL1/4F | TCL1/2H | TCL1/4R | - | - | .0156 | 1/64 | .018 | 77 | .020 | 76 | .022 | 74 | .025 | 72 |
| TCL1/2F | TCL1H | TCL1/2R | .018 | 77 | .021 | 75 | .024 | 73 | .026 | 71 | .0292 | 69 | .035 | 65 |
| TCL1F | TCL2H | TCL1R | .026 | 71 | .0312 | 1/32 | .036 | 64 | .040 | 60 | .0465 | 56 | .052 | 55 |
| TCL2F | TCL3H | TCL2R | .028 | 70 | .035 | 65 | .040 | 60 | .043 | 57 | .0468 | 3/64 | .055 | 54 |
| TCL3F | TCL5H | TCL3R | .035 | 65 | .043 | 57 | .052 | 55 | .055 | 54 | .0625 | 1/16 | .070 | 50 |
| TCL4F | TCL7-1/2H | TCL4-1/2R | .043 | 57 | .052 | 55 | .0595 | 53 | .067 | 51 | .076 | 48 | .086 | 44 |
| TCL6-1/2F | TCL10H | TCL7R | .052 | 55 | .0595 | 53 | .070 | 50 | .0785 | 47 | .086 | 44 | .0995 | 39 |
| TCL7-1/2F | TCL12H | TCL8R | .052 | 55 | .0595 | 53 | .070 | 50 | .0785 | 47 | .086 | 44 | .0995 | 39 |

*Bleed hole sizes shown above are based on a percent of full effective port area of valve. This does not necessarily indicate the percent of valve capacity that will be by-passed. The hole sizes shown above should be used for reference only. The following tolerance applies to the bleed hole diameters:

.0135 to .060 dia. +.002
-.001

0.061 to 0.115 dia. +.0030
-.0015

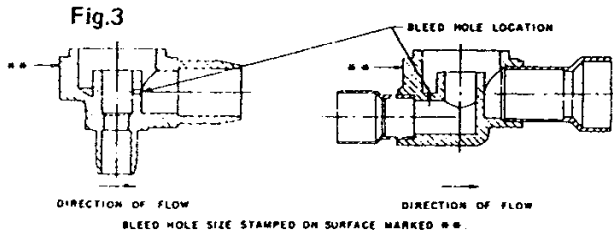

TABLE 4 - INTERCHANGEABLE COMPONENTS

| VALVE SIZES | | | CAGE ASSY. PART NO. | STANDARD CONNECTIONS | | | POWER ASSY. PART NO. |
|---------------|-------------|-------------|---------------------|---|---------------------|--------------|-----------------------------------|
| R-12 | R-22 | R-502 | | TO BE FURNISHED IF NOT SPECIFIED ON ORDER | STRAIGHT THRU STYLE | ANGLE STYLES | |
| TCL(E)1/4FW | TCL(E)1/2HW | TCL(E)1/4RW | X22440-81* | 3/8 x 5/8 | 3/8x1/2 ODF | 1/4x3/8 ODF | XB1019-** (Standard Bulb) |
| TCL(E)1/2FW | TCL(E)1HW | TCL(E)1/2RW | X22440-82* | | 3/8x5/8 ODF | 3/8x1/2 ODF | |
| TCL(E)1FW | TCL(E)2HW | TCL(E)1RW | X22440-83* | | 1/2x1/2 ODF | 1/2x5/8 ODF | |
| TCL(E)2FW | TCL(E)3HW | TCL(E)2RW | X22440-84* | | 5/8x7/8 ODF | 5/8x5/8 ODF | |
| TCL(E)3FW | TCL(E)5HW | TCL(E)3RW | X22440-85* | | 5/8x7/8 ODF | 5/8x7/8 ODF | |
| TCL(E)4FW | TCL(E)7/8HW | TCL(E)4/8RW | X22440-86* | 1/2 x 5/8 | 5/8x1-1/8 ODF | 5/8x7/8 ODF | X8019-** (Rapid Response Bulb) |
| TCL(E)6-1/2FW | TCL(E)10HW | TCL(E)7RW | X22440-87* | | 7/8x1-1/8 ODF | 3/8x1/2 SAE | |
| TCL(E)7-1/2FW | TCL(E)12HW | TCL(E)8RW | X22440-88* | 5/8 x 7/8 | 3/8x1/2 SAE | 3/8x5/8 SAE | |
| | | | | | 1/2x1/2 SAE | 1/2x5/8 SAE | |

*Add "A" for internal or "B" for external equalizer.

**Add: Refrigerant charge - FW=R12, HW=R22, RW=R502 etc.

Tubing Length - 1=5', 2=10', 3=15', etc.

Equalizer Code - A=internal, B=1/4" external (example: XB1019-FW100-1B)

Note: Do not use an externally equalized cage assembly with an internally equalized power assembly or vice versa.

OLD VS. NEW NOMENCLATURE

New cage assemblies are interchangeable with the old versions. To modernize our product, minor changes have been made in the construction of cage assemblies. The new constructions have been identified by a new cage assembly part number and a new valve type number.

| OLD STYLE | | | | NEW STYLE | | | |
|------------|-----------|----------|---------------------------|------------|------------|------------|---------------------------|
| VALVE TYPE | | | CAGE ASSEMBLY PART NUMBER | VALVE TYPE | | | CAGE ASSEMBLY PART NUMBER |
| R-12 | R-22 | R-502 | | R-12 | R-22 | R-502 | |
| TCLE25F | TCLE50H | TCLE25R | XC709-B7* | TCLE1/4F | TCLE1/2H | TCLE1/4R | X22440-B1* |
| TCLE50F | TCLE100H | TCLE50R | XC709-B000* | TCLE1/2F | TCLE1H | TCLE1/2R | X22440-B2* |
| TCLE100F | TCLE200H | TCLE100R | XC709-B00* | TCLE1F | TCLE2H | TCLE1R | X22440-B3* |
| TCLE200F | TCLE300H | TCLE200R | XC709-B0* | TCLE2F | TCLE3H | TCLE2R | X22440-B4* |
| TCLE250F | TCLE400H | TCLE250R | XC709-B6* | TCLE3F | TCLE5H | TCLE3R | X22440B5* |
| TCLE300F | TCLE500H | TCLE300R | XC709-B1* | | | | |
| TCLE400F | TCLE700H | TCLE450R | XC709-B4* | TCLE4F | TCLE7-1/2H | TCLE4-1/2R | X22440-B6* |
| TCLE600F | TCLE900H | TCLE650R | XC709-B2* | TCLE6-1/2F | TCLE10H | TCLE7R | X22440-B7* |
| TCLE650F | TCLE1000H | TCLE700R | XC709-B3* | | | | |
| TCLE750F | TCLE1200H | TCLE800R | XC709-B5* | TCLE7-1/2F | TCLE12H | TCLE8R | X22440-B8* |

NOTE: Delete letter 'E' from valve type for internally equalized valve. *Equalizer code letter 'A' (internal) or 'B' (external) is added to the basic numbers shown to make complete cage assembly part number.

TABLE 6
TCL(E) ROUGHING IN DIMENSIONS

| CAPILLARY TUBING LENGTH | STANDARD REMOTE BULB | | RAPID RESPONSE BULB | |
|-------------------------|----------------------|---------|---------------------|--------|
| | DIAM. | LENGTH | DIAM. | LENGTH |
| 5' | 5/8 | 3-1/16 | 3/8 | 1-3/16 |
| 10' | | 3-9/16 | | |
| 15 or 20' | | 4-13/16 | | |
| 30' | | 6-1/16 | | |
| 40 or 50' | 3/4 | 6-3/16 | X | |

Rapid response bulb available only with 5' or 10' capillary tubing.

STRAIGHT-THRU STYLE

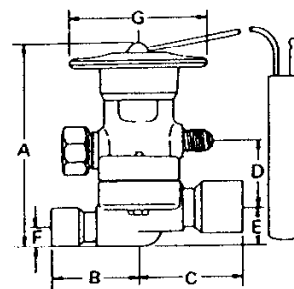

ANGLE STYLE

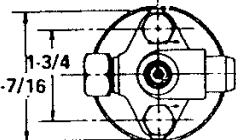
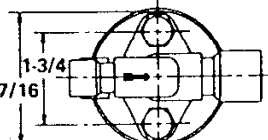
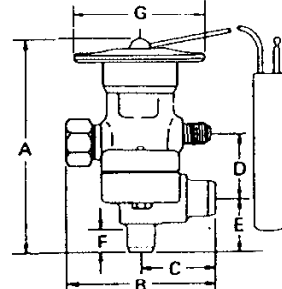

TCL(E)

| STRAIGHT-THRU STYLE | | | | | | | | | | |
|-----------------------|------------|---------|---------|---------|---------|-----|--------|--------------|--------|-------|
| *STANDARD CONNECTIONS | DIMENSIONS | | | | | | | SOCKET DEPTH | | |
| | A | B | C | D | E | F | G | INLET | OUTLET | |
| 3/8 x 1/2 SAE | 3-45/64 | 1-25/32 | 1-63/64 | 1-13/64 | 11/16 | 3/8 | 2-9/16 | 5/16 | 3/8 | |
| 3/8 x 5/8 SAE | | 1-31/32 | 1-9/16 | | | | | | | |
| 1/2 x 1/2 SAE | | 1-13/32 | 1-37/64 | | | | | | | |
| 3/8 x 1/2 ODF | 3-11/16 | 1-13/32 | 1-5/8 | 1-13/64 | 11/16 | 3/8 | DIA. | 3/8 | 1/2 | |
| 3/8 x 5/8 ODF | 1-5/8 | | 43/64 | | | | | | | 23/64 |
| 1/2 x 1/2 ODF | 3-45/64 | | 1-9/16 | | | | | | | 43/64 |
| 1/2 x 5/8 ODF | 3-11/16 | 1-19/32 | 1-5/8 | 1-13/64 | 11/16 | 3/8 | DIA. | 1/2 | 1/2 | |
| 5/8 x 5/8 ODF | 1-5/8 | | 1-15/16 | | | | | | | |
| 5/8 x 7/8 ODF | 3-45/64 | | 2-3/8 | | | | | | | |
| 5/8 x 1-1/8 ODF | 3-13/16 | 1-15/16 | 2-3/8 | 1-13/64 | 1-11/16 | 3/8 | DIA. | 3/4 | 29/32 | |
| 7/8 x 1-1/8 ODF | 1-15/16 | 2-3/8 | | | | | | | | |

ANGLE STYLE

| | | | | | | | | | | | | | | |
|---------------------------------|---------|---------|---------|---------|---------|-------|--------|---|---------|---------|-------|------|---|-------|
| 3/8 x 1/2 SAE | 4-9/64 | 3-1/16 | 1-1/2 | 1-13/64 | 1-1/8 | - | 2-9/16 | - | 9/16 | | | | | |
| 3/8 x 5/8 SAE | 3-3/16 | 1-5/8 | 1-11/32 | | | | | | | 1-3/8 | - | DIA. | - | 11/16 |
| 1/2 x 5/8 SAE | 4-25/64 | 1-11/32 | | | | | | | | | | | | |
| 1/4 x 3/8 ODF | 3-61/64 | 2-29/32 | 1-11/32 | 1-3/16 | 11/16 | DIA. | - | - | | | | | | |
| 3/8 x 1/2 ODF | 4-7/64 | 3-1/32 | 1-15/32 | | | | | | 4-13/64 | 3-9/16 | DIA. | - | - | |
| 3/8 x 5/8 ODF | 4-13/64 | 3-5/32 | 1-19/32 | 4-53/64 | 3-9/16 | DIA. | - | - | | | | | | |
| 1/2 x 5/8 ODF | 4-13/64 | 3-9/16 | 2 | | | | | | 1-11/32 | 1-11/16 | 13/16 | - | - | |
| 5/8 x 7/8 ODF (7/8 x 1-1/8 ODM) | 4-53/64 | 3-9/16 | 2 | 1-11/32 | 1-11/16 | 13/16 | - | - | | | | | | |

* Consult Alco for dimensions of non-standard connections. Allow 2 1/8" above Valve for removal of Power Assembly

REMOTE BULB WELL

When it becomes desirable to increase the sensitivity of the remote bulb to a change in the refrigerant gas temperature leaving the evaporator, it may be necessary to use a remote bulb well. This is particularly true for short coupled installations with large suction lines (2-1/8" OD or larger). Remote bulb wells should be used (1) when very low superheats are desired and (2) where convected heat from a warm room can influence the remote bulb. (See Figure 4.)

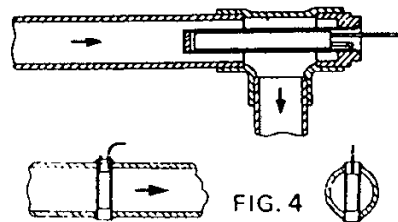

RAPID RESPONSE BULB AND WELL

One of the problems encountered in the average refrigeration system is the return of liquid refrigerant to the compressor or "flood-back". Proper application of the ALCO rapid response remote bulb and matching well will minimize this problem. Due to reduced thermal mass, the rapid response bulb and well respond to changes in suction gas superheat far more rapidly than the larger standard remote bulbs applied either as "strapped" type or inserted in the standard remote bulb well.

The rapid response bulb and well provide the extra quick closing action necessary for positive protection against liquid "flood-back" as well as the smooth control necessary for optimum system performance. Figure 4 illustrates the proper method of installation. The rapid response bulb may be used in either horizontal or vertical suction lines.

Since a definite remote bulb volume is required for any type of charge other than gas, the rapid response bulb is available only with the "G" (gas) charge. To designate the rapid response bulb, suffix the charge symbol in the valve type or power assembly number with the letter "S", i.e., TCL1-FGS55 or X7726-FGS55 1A.

Do not under any circumstances locate either type of remote bulb in a location where the suction line is trapped. (See Figure 1.) If the liquid refrigerant collects at the point of remote bulb location, the Thermo Expansion Valve operation will be erratic and possibly the valve thought to be defective. Large fluctuations in superheat in the suction gas are usually the result of trapped liquid at the remote bulb location. Even on properly designed suction lines, it is sometimes necessary to move the remote bulb a few inches either way from the original location to obtain best valve action. Always locate the remote bulb on the evaporator side of the heat exchanger.

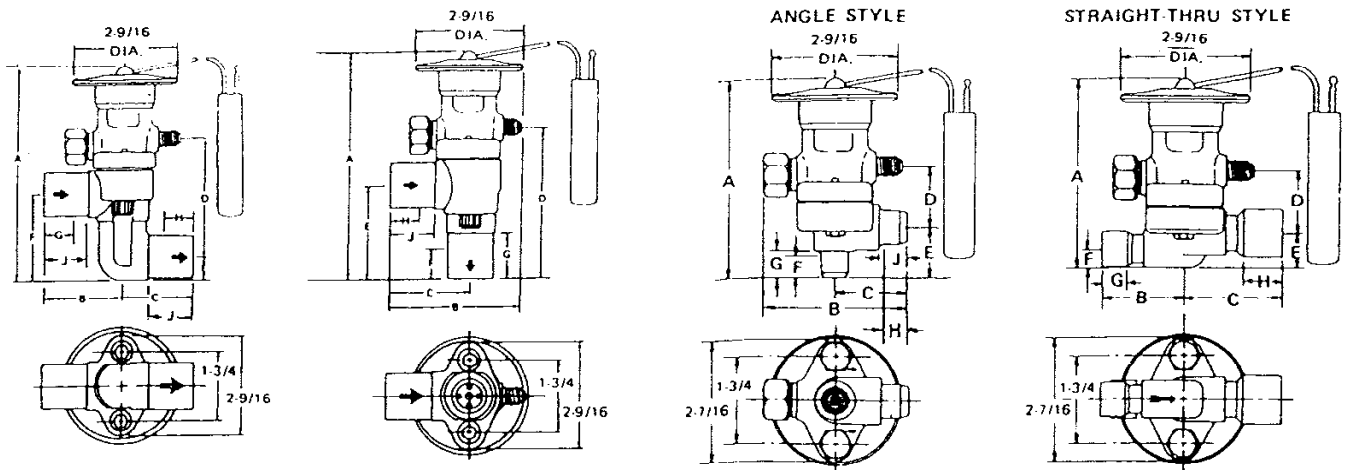

TJR

TJLE

ROUGHING IN DIMENSIONS

| VALVE TYPE | *STANDARD CONNECTIONS | | DIMENSIONS | | | | | | | | |
|---------------------------|-----------------------|-----------|------------|---------|---------|---------|---------|---------|--------|-------|-------|
| | INLET | OUTLET | A | B | C | D | E | F | G | H | J |
| STRAIGHT-THRU CONNECTIONS | | | | | | | | | | | |
| TJLE | 5/8 | 1-1/8 | 4-55/64 | 1-5/8 | 2-1/2 | 1-11/32 | 1-23/32 | 45/64 | 17/32 | 29/32 | |
| | 7/8 | 1-1/8 | | 1-15/16 | 2-1/2 | | | | 3/4 | 29/32 | |
| TJR | ODF/ODM | ODF/ODM | 5-23/64 | 2 | 1-25/32 | 2-15/16 | 19/32 | 2-13/64 | 3/4 | 3/4 | 1-1/8 |
| | 7/8/1-1/8 | 7/8/1-1/8 | | | | | | | | | |
| ANGLE CONNECTIONS | | | | | | | | | | | |
| TJLE | ODF/ODM | ODF/ODM | 5-1/32 | 3-15/32 | 2 | 1-11/32 | 1-27/32 | 13/16 | 1-1/16 | 1 | 1-1/8 |
| TJR | 7/8/1-1/8 | 7/8/1-1/8 | 5-1/2 | 3-3/8 | 2 | 3-21/32 | 2-5/16 | 3/4 | 1-1/8 | 3/4 | 1-1/8 |

REMOTE BULB DIMENSIONS

| VALVE TYPE | CAPIL-LARY TUBING LENGTH | STANDARD REMOTE BULB | | RAPID RESPONSE BULB | |
|------------|--------------------------|----------------------|---------|---------------------|--------|
| | | DIAM. | LENGTH | DIAM. | LENGTH |
| TJLE | 5' | 5/8 | 3-1/16 | 3/8 | 1-3/16 |
| | 10' | | 3-9/16 | | |
| | 15' or 20' | | 4-13/16 | | |
| | 30' | | 6-1/16 | | |
| TJR | 40' or 50' | 3/4 | 6-3/16 | | |

Rapid response bulb available only with 5' or 10' capillary tubing.

*Consult Alco for Dimensions of Non-Standard Connections.

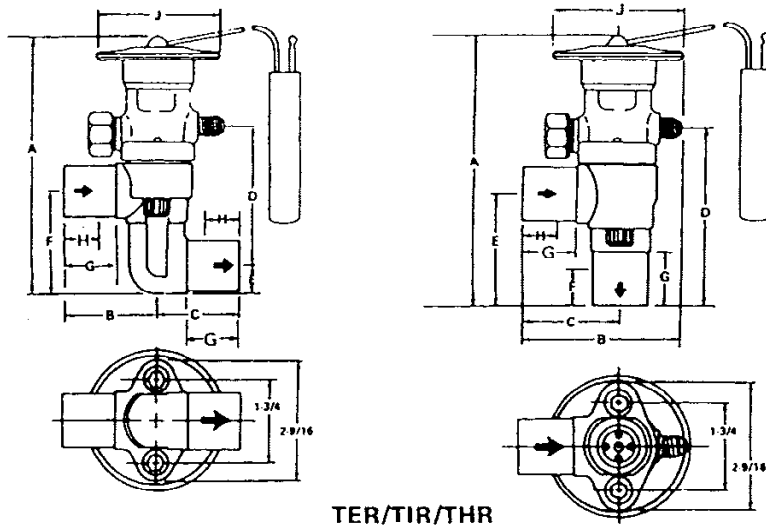

TER/TIR/THR

ROUGHING IN DIMENSIONS

| VALVE TYPE | CONNECTIONS | | DIMENSIONS | | | | | | | | |
|---------------------------|-------------|-----------|------------|-------|---------|---------|---------|---------|-------|-----|-------------|
| | INLET | OUTLET | A | B | C | D | E | F | G | H | J |
| STRAIGHT-THRU CONNECTIONS | | | | | | | | | | | |
| TER | ODF/ODM | ODF/ODM | 5-25/64 | 2 | 1-25/32 | 2-15/16 | 19/32 | 2-13/64 | 1-1/8 | 3/4 | 2-7/8 Diam. |
| | 7/8/1-1/8 | 7/8/1-1/8 | | | | | | | | | |
| TIR | ODM | ODM | 5-29/64 | 2 | 1-25/32 | 3 | 19/32 | 2-17/64 | 1-1/8 | 3/4 | 2-7/8 Diam. |
| | 7/8/1-1/8 | 7/8/1-1/8 | | | | | | | | | |
| THR | 1-1/8 | 1-1/8 | 5-29/64 | 2 | 1-25/32 | 3 | 19/32 | 2-17/64 | - | - | |
| ANGLE CONNECTIONS | | | | | | | | | | | |
| TER | ODF/ODM | ODF/ODM | 5-1/2 | 3-3/8 | 2 | 3-21/32 | 2-5/16 | 3/4 | 1-1/8 | 3/4 | 2-7/8 Diam. |
| TIR | 7/8/1-1/8 | 7/8/1-1/8 | 6 | | 2 | 4-5/32 | 2-13/16 | 3/4 | 1-1/8 | 3/4 | |
| THR | 1-1/8 | 1-1/8 | 6 | | 2 | 4-5/32 | 2-13/16 | - | 1-1/8 | - | |

Allow 2-1/8" above valve for removal of power assembly.

For further information on Alco thermo valves, see Bulletin 12.01.11 "Thermo Expansion Valve Service Hints."

ADDITIONAL INFORMATION Products, specifications and data in this literature are subject to change without notice. Questions regarding product selection for specific applications should be directed to Alco Technical Service Department, Alco Controls, St. Louis, Missouri.



ALCO CONTROLS DIVISION • EMERSON ELECTRIC CO.
P. O. BOX 12700 • ST. LOUIS, MISSOURI 63141
PHONE (314) 569-4500 • TELEX 447-162



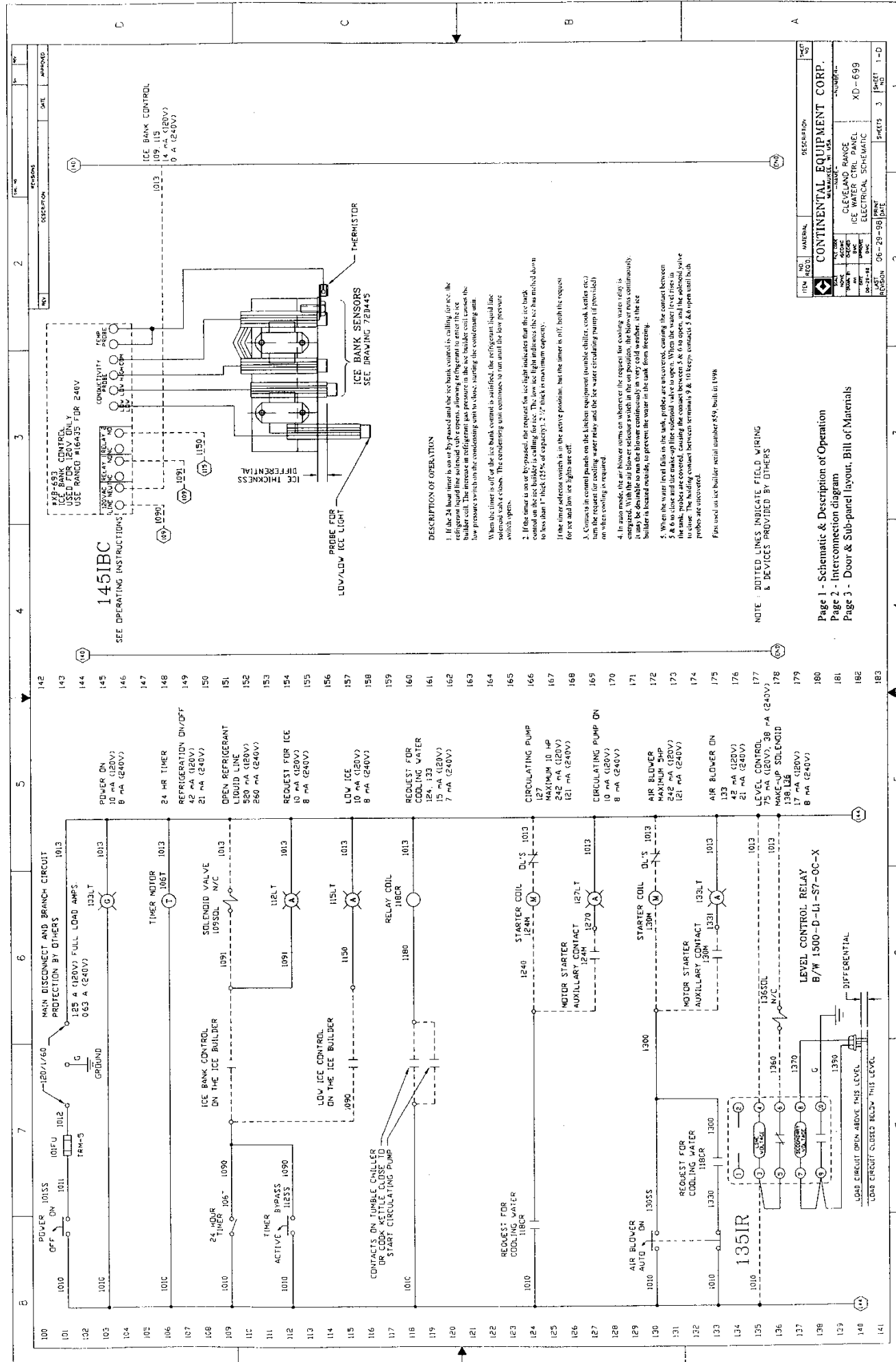

| REV | NO. | MATERIAL | DESCRIPTION | NO. |
|-----|-----|-----------------------------|----------------------|--------|
| 1 | 1 | CONTINENTAL EQUIPMENT CORP. | ICE BANK CONTROL | 1451BC |
| 2 | 2 | CLEVELAND RANGE | ELECTRICAL SCHEMATIC | XD-699 |
| 3 | 3 | ICE BANK CONTROL | ELECTRICAL SCHEMATIC | XD-699 |
| 4 | 4 | ICE BANK CONTROL | ELECTRICAL SCHEMATIC | XD-699 |

Page 1 - Schematic & Description of Operation
 Page 2 - Interconnection diagram
 Page 3 - Door & Sub-panel layout, Bill of Materials

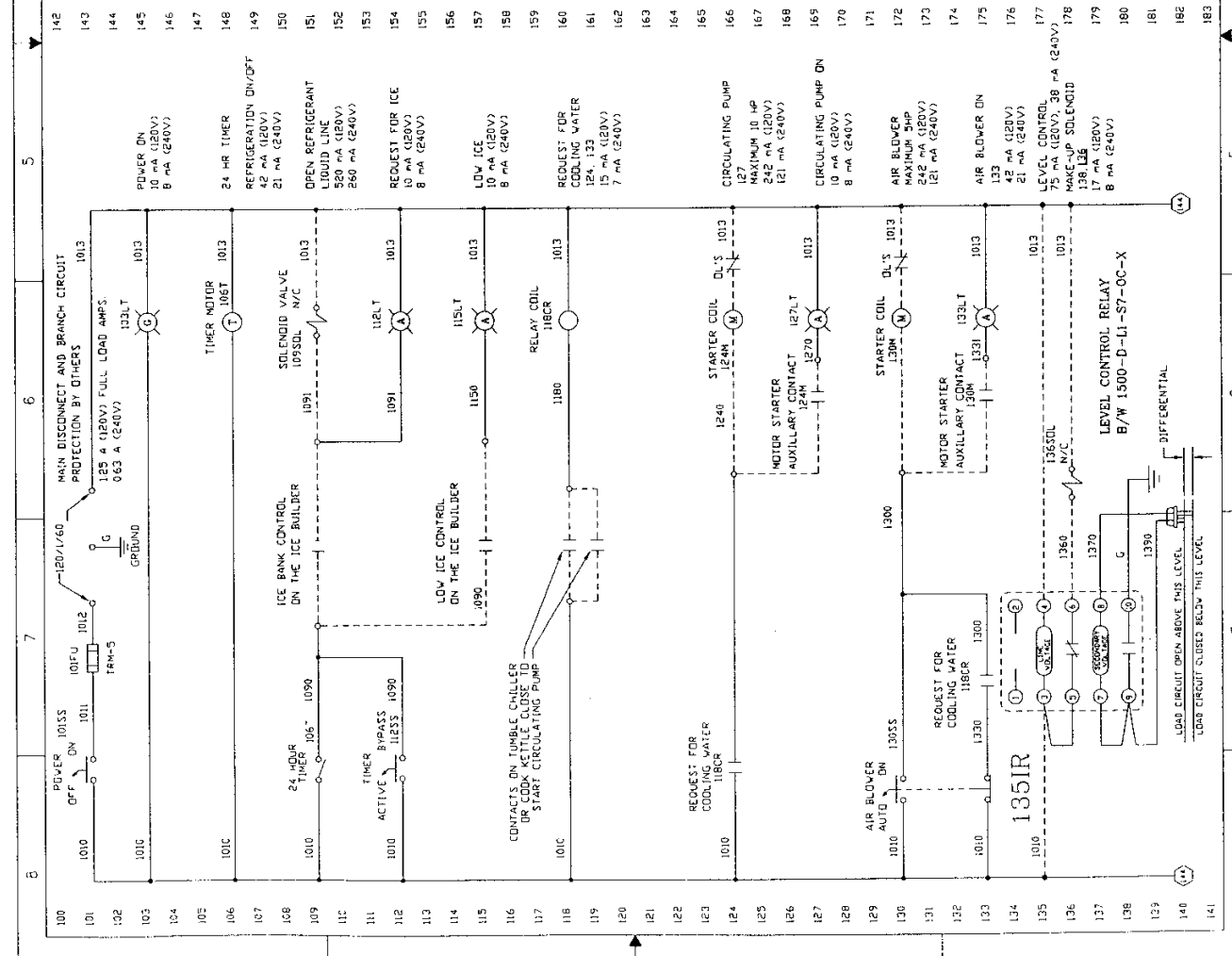

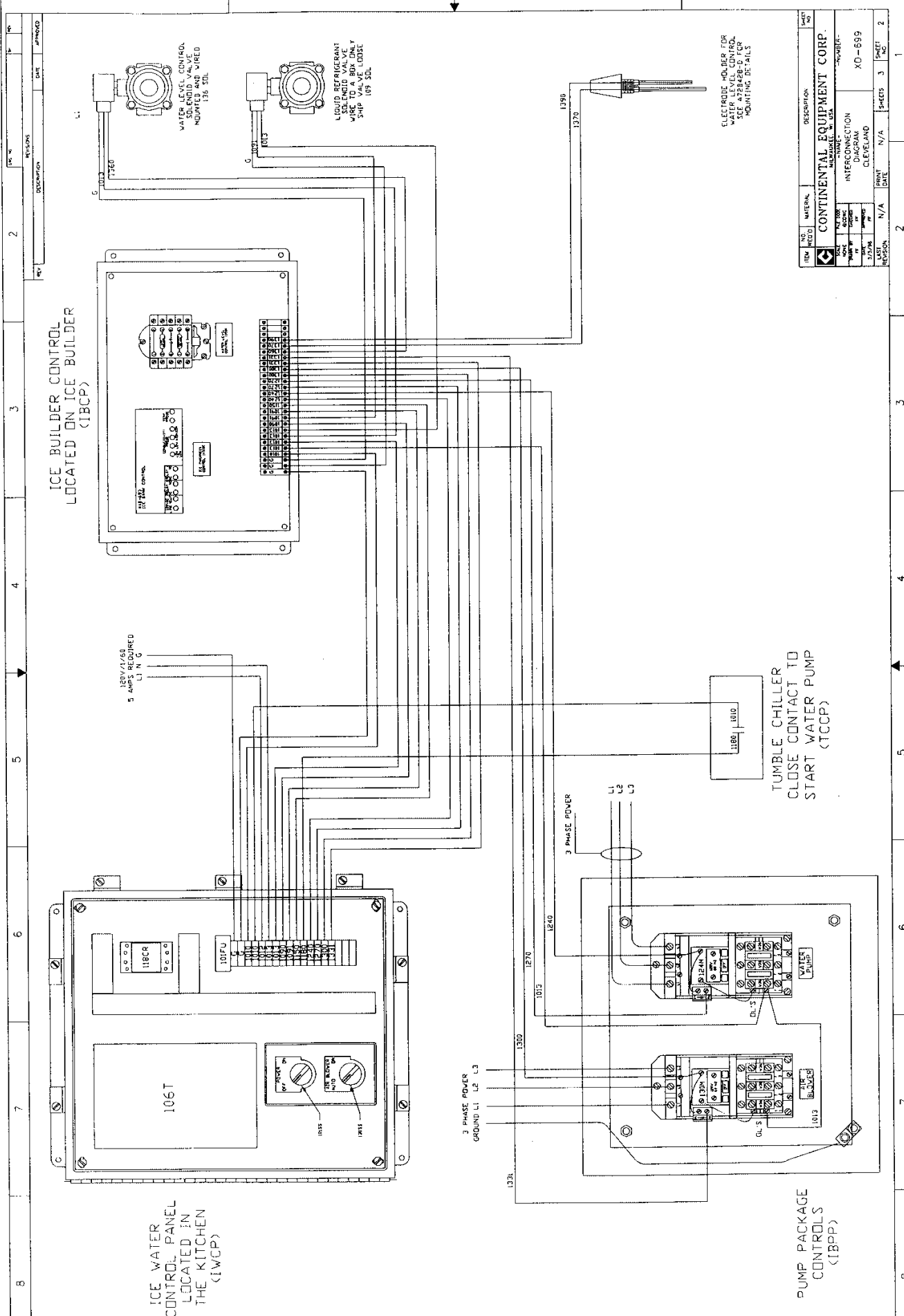

| ITEM NO. | QTY | MATERIAL | DESCRIPTION | SHEET NO. |
|----------|-----|--|--|-----------|
| 1 | 1 | WATER LEVEL CONTROL | WATER LEVEL CONTROL | 1 |
| 2 | 1 | LIQUID REFRIGERANT SERVICE VALVE | LIQUID REFRIGERANT SERVICE VALVE | 1 |
| 3 | 1 | TUMBLE CHILLER CLOSE CONTACT TO START WATER PUMP | TUMBLE CHILLER CLOSE CONTACT TO START WATER PUMP | 1 |

| | | | |
|-----------------------------|-------------|-----------------|-------------|
| CONTINENTAL EQUIPMENT CORP. | | CLEVELAND, OHIO | |
| DATE | 12/27/78 | PRINTED | ON |
| BY | J. J. JONES | CHECKED | J. J. JONES |
| APPROVED | | DATE | |
| INTERCONNECTION DIAGRAM | | NO. 699 | |
| PROJECT NO. | | XD-699 | |
| SHEET NO. | | 3 | |
| TOTAL SHEETS | | 3 | |

REV. NO. 2
 DATE APPROVED
 DESCRIPTION
 REVISIONS

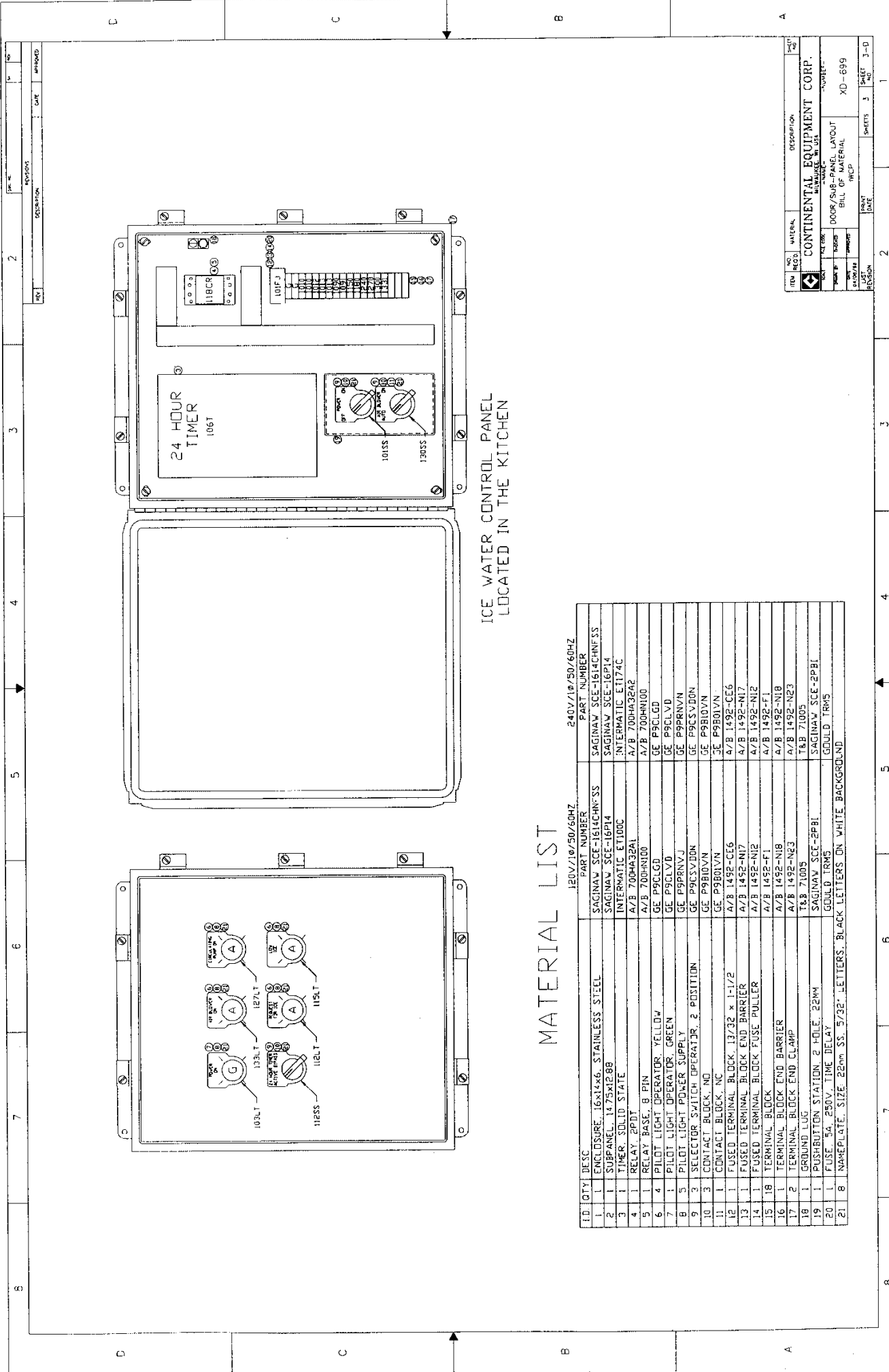

ICE WATER CONTROL PANEL
LOCATED IN THE KITCHEN

MATERIAL LIST

| | | 120V/1Ø/50/60HZ | | 240V/1Ø/50/60HZ | |
|----|-----|--|------------------------|------------------------|--|
| ID | QTY | DESC | PART NUMBER | PART NUMBER | |
| 1 | 1 | ENCLOSURE, 16A1x6, STAINLESS STEEL | SAGINAW SCE-1614CHN-SS | SAGINAW SCE-1614CHN-SS | |
| 2 | 1 | SUBPANEL, 14.75x12.88 | SAGINAW SCE-16P14 | SAGINAW SCE-16P14 | |
| 3 | 1 | TIMER, SOLID STATE | INTERMATIC ET100C | INTERMATIC ET174C | |
| 4 | 1 | RELAY, 2PDT | A/B 700HA32A1 | A/B 700HA32A2 | |
| 5 | 1 | RELAY BASE, 8 PIN | A/B 700HN100 | A/B 700HN100 | |
| 6 | 4 | PILOT LIGHT OPERATOR, YELLOW | GE P9CLGD | GE P9CLGD | |
| 7 | 1 | PILOT LIGHT OPERATOR, GREEN | GE P9CLVD | GE P9CLVD | |
| 8 | 3 | PILOT LIGHT POWER SUPPLY | GE P9PRNVJ | GE P9PRNVN | |
| 9 | 3 | SELECTOR SWITCH OPERATOR, 2 POSITION | GE P9CSVDN | GE P9CSVDN | |
| 10 | 3 | CONTACT BLOCK, NC | GE P9B0VNV | GE P9B0VNV | |
| 11 | 1 | CONTACT BLOCK, NC | GE P9B01VN | GE P9B01VN | |
| 12 | 1 | FUSED TERMINAL BLOCK, 13/32 x 1-1/2 | A/B 1492-CE6 | A/B 1492-CE6 | |
| 13 | 1 | FUSED TERMINAL BLOCK END BARRIER | A/B 1492-N17 | A/B 1492-N17 | |
| 14 | 1 | FUSED TERMINAL BLOCK FUSE PULLER | A/B 1492-N12 | A/B 1492-N12 | |
| 15 | 18 | TERMINAL BLOCK | A/B 1492-F11 | A/B 1492-F11 | |
| 16 | 1 | TERMINAL BLOCK END BARRIER | A/B 1492-N18 | A/B 1492-N18 | |
| 17 | 2 | TERMINAL BLOCK END CLAMP | A/B 1492-NE3 | A/B 1492-NE3 | |
| 18 | 1 | GROUND LUG | T&B 71005 | T&B 71005 | |
| 19 | 1 | PUSHBUTTON STATION, 2 HOLE, 22MM | SAGINAW SCE-2PBI | SAGINAW SCE-2PBI | |
| 20 | 1 | FUSE, 5A, 250V, TIME DELAY | GOULD TRMS | GOULD TRMS | |
| 21 | 8 | NAMEPLATE, SIZE: 22mm SS, 5/32" LETTERS, BLACK LETTERS ON WHITE BACKGROUND | GOULD TRMS | GOULD TRMS | |

| ITEM | NO. | MATERIAL | DESCRIPTION | REV. |
|------|-----|-----------------------------|--------------------------------|------|
| 1 | 1 | CONTINENTAL EQUIPMENT CORP. | ICE WATER CONTROL PANEL LAYOUT | 1 |
| 2 | 1 | CONTINENTAL EQUIPMENT CORP. | BILL OF MATERIAL | 2 |
| 3 | 1 | CONTINENTAL EQUIPMENT CORP. | REVISION | 3 |

Solenoid Valve

Type S8F

Port Size: 13mm (1/2")

For Ammonia, R-12, R-22, R-502,
and other common Refrigerants.

Features

- Standard Coil Housing Meets NEMA 3R and NEMA 4 – Rain Tight
- Coil Housing Surpasses NEMA Salt Spray Test
- Plunger-Needle Assembly Same For S4A, S5A, S6N, S6A
- Replaceable Piston Plug Assembly
- Molded Class "B" Coil Construction
- Same Coil Fits All Refrigerating Specialties Solenoid Valves
- Pilot Light Available
- Stainless Steel Needle, Teflon® Seats
- Manual Opening Stem
- MOPD and MRP 20.7 bar (300 PSIG)

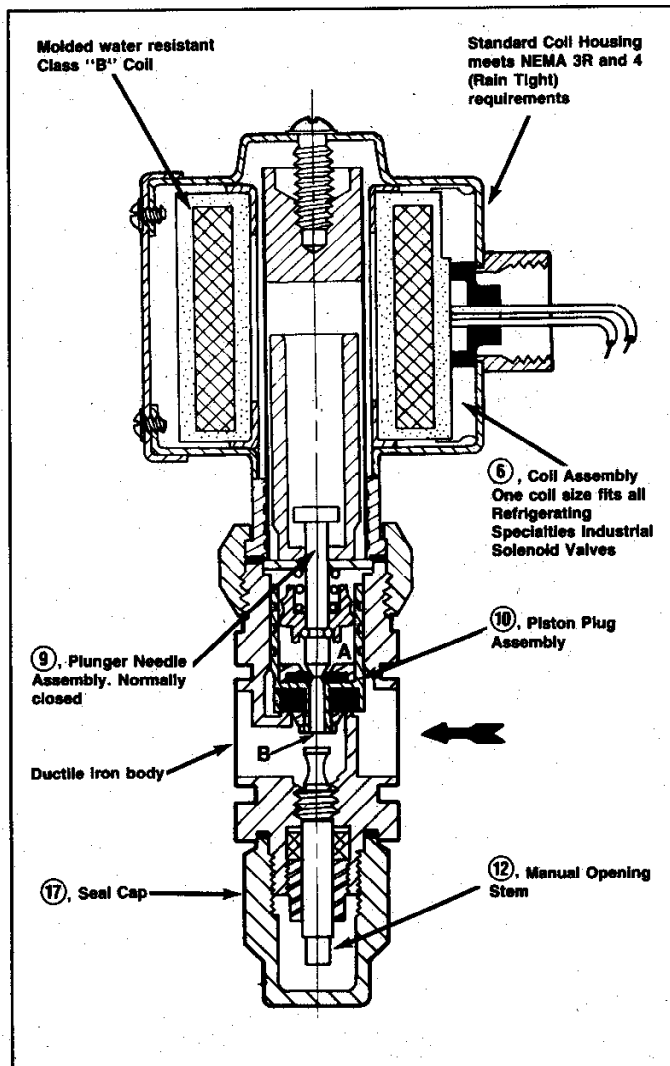

Bulletin 30-91E
Type S8F

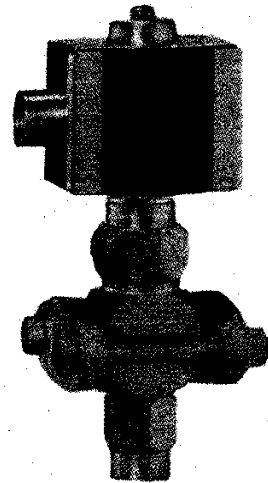

March 1991
Installation, Service and Parts Information

Description

This compact, heavy duty, pilot-operated, plated ductile iron bodied solenoid valve is suitable for Ammonia, R-12, R-22, R-502 and other common refrigerants for liquid, suction and hot gas lines, and refrigerant oil lines. The plunger-needle assembly is also used with most other Refrigerating Specialties Industrial Solenoid Valves. This valve is usually ordered with a close-coupled stainless steel screen strainer. (See current Bulletin 00-10 for strainer information.)

Purpose

A solenoid valve is an electrically operated device used to control the flow of liquids or gases in a fully open or fully closed configuration. The S8F is a normally closed solenoid valve to control the flow of refrigerant. Like all Refrigerating Specialties Solenoid Valves, this valve does not modulate. When electrically energized a slight fluid pressure difference across the Valve causes it to promptly open wide; when de-energized, the Main Valve promptly closes to stop all flow in the normal direction.

Principles of Operation

This is a pilot operated Solenoid Valve. A small Pilot Port is opened by a magnetically lifted Plunger-Needle Assembly; the consequent relief of pressure from the top of a Main Valve and Piston Assembly allows the Assembly to be lifted by the pressure difference between valve inlet and valve outlet. A minimum pressure difference of approximately 1 psi is required for operation.

Operation is as follows, starting with a closed valve: When energized, #6 Solenoid Coil forms a magnetic field which pulls #9 Solenoid Plunger upward, striking Valve Needle and pulling it up from its Pilot Seat to permit fluid travel from Chamber A (in and above #10 Piston Plug Assembly) through Orifice B in #10 Piston Plug Assembly to the downstream side of the Valve. When the pressure in Chamber A has dropped almost to the downstream pressure, the higher upstream pressure, acting on the annular portion of #10 Piston Plug Assembly outside of the Seat Bead, will lift the Main Valve to open position.

When the electrical circuit to the S8F Valve is broken, #6 Solenoid Coil is de-energized, allowing #9 Solenoid Plunger to drop and Valve Needle to close the Pilot Port in #10 Piston Plug. Liquid and/or gas leakage through the clearance area around #10 Piston Plug causes a rapid pressure build up in Chamber A which combines with the downward force of the Spring which is part of #9 Solenoid Plunger and the weight of #10 Piston Plug Assembly to force the Main Valve Disc tight against the Seat Bead to stop all flow.

Manual Opening

To manually open the S8F Solenoid Valve, cautiously remove #17 Seal Cap and turn #12 Manual Opening Stem in (clockwise viewed from beneath). The rising Stem will lift #10 Piston Plug Assembly from its seat and permit flow. To resume automatic operation, turn #12 Manual Opening Stem out (counter-clockwise viewed from beneath) until it stops and replace #17 Seal Cap.

Repair Kits For Type S8F Solenoid Valve

| Item | Description | Qty. | Kit Number |
|-----------|--|------|---|
| 1 | Screw | 1 | Only Available With Kit |
| 2 | Housing, Coil | 1 | Only Available With Kit |
| 3 | Bushing, Seal | 1 | Only Available With Kit |
| 4 | Cover, Solenoid | 1 | Only Available With Kit |
| 5 | Screw | 2 | Only Available With Kit |
| 1-5 | Housing Kit | 1 | 201629 |
| 6 | Coil Assembly | 1 | See Part No. Page 4 |
| 7 | Tube Assembly | 1 | Only Available With Kit |
| 8 | Gasket | 1 | Only Available With Kit |
| 7-8 | Tube Kit | 1 | 201036 |
| 9 | Plunger Needle Assembly** | 1 | Only Available With Kit |
| 10 | Piston Plug Assembly | 1 | Only Available With Kit |
| 8-10 | Plunger Piston Kit** | 1 | 202072 |
| 11 | Body, S8F | 1 | Not Available Separately |
| 12 | Stem, Manual Opening | 1 | Only Available With Kit |
| 13 | Washer | 1 | Only Available With Kit |
| 14 | Packing, Stem | 1 | Only Available With Kit |
| 15 | Nut, Packing | 1 | Only Available With Kit |
| 12-15 | Stem Kit, Opening | 1 | 202238 |
| 16 | "O"-Ring | 1 | Only Available With Kit |
| 17 | Seal Cap | 1 | Only Available With Kit |
| 16-17 | Cap Kit | 1 | 202713 |
| 18 | Flange Kit (Specify Flange Style & Connection Size) Includes 2 Flanges Only. Sold Separately | 1 | FK-13. Also Specify Size and Style of Connection. |
| 19 | Bolt | 2 | Only Available With Kit |
| 20 | Nut | 2 | Only Available With Kit |
| 21 | Gasket (*2 If Without Strainer, 3 If With Strainer) | * | Only Available With Kit |
| 19-21 | Bolt Kit (S8F Without Strainer) | - | 201290 |
| 19-21 | Bolt Kit (S8F With Strainer) | - | 201287 |
| 8, 16, 21 | Gasket Kit (Includes 2 Flange Gaskets) | - | 201632 |
| 7-17, 21 | Complete Valve Body Assembly | 1 | 100997 |

** Not for D.C. Consult factory for correct parts.
 Allow 100mm (4.0") above valve for removal of coil housing and coil.
 Allow 25mm (1.0") below valve to operate manual opening stem.

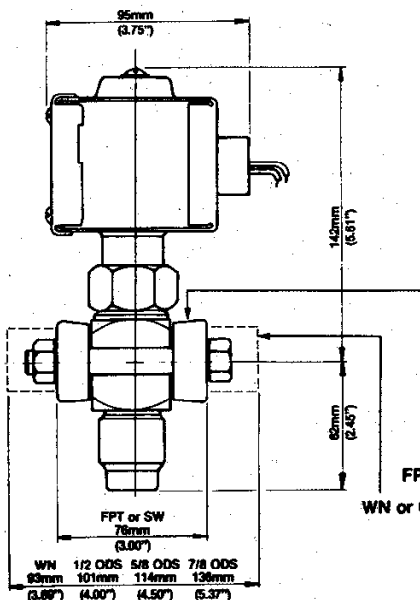

S8F Without Strainer

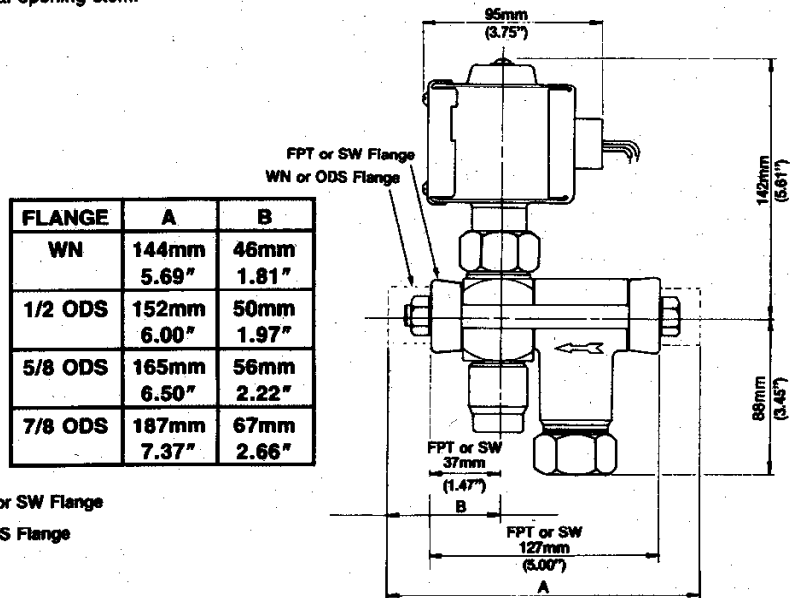

S8F With Strainer

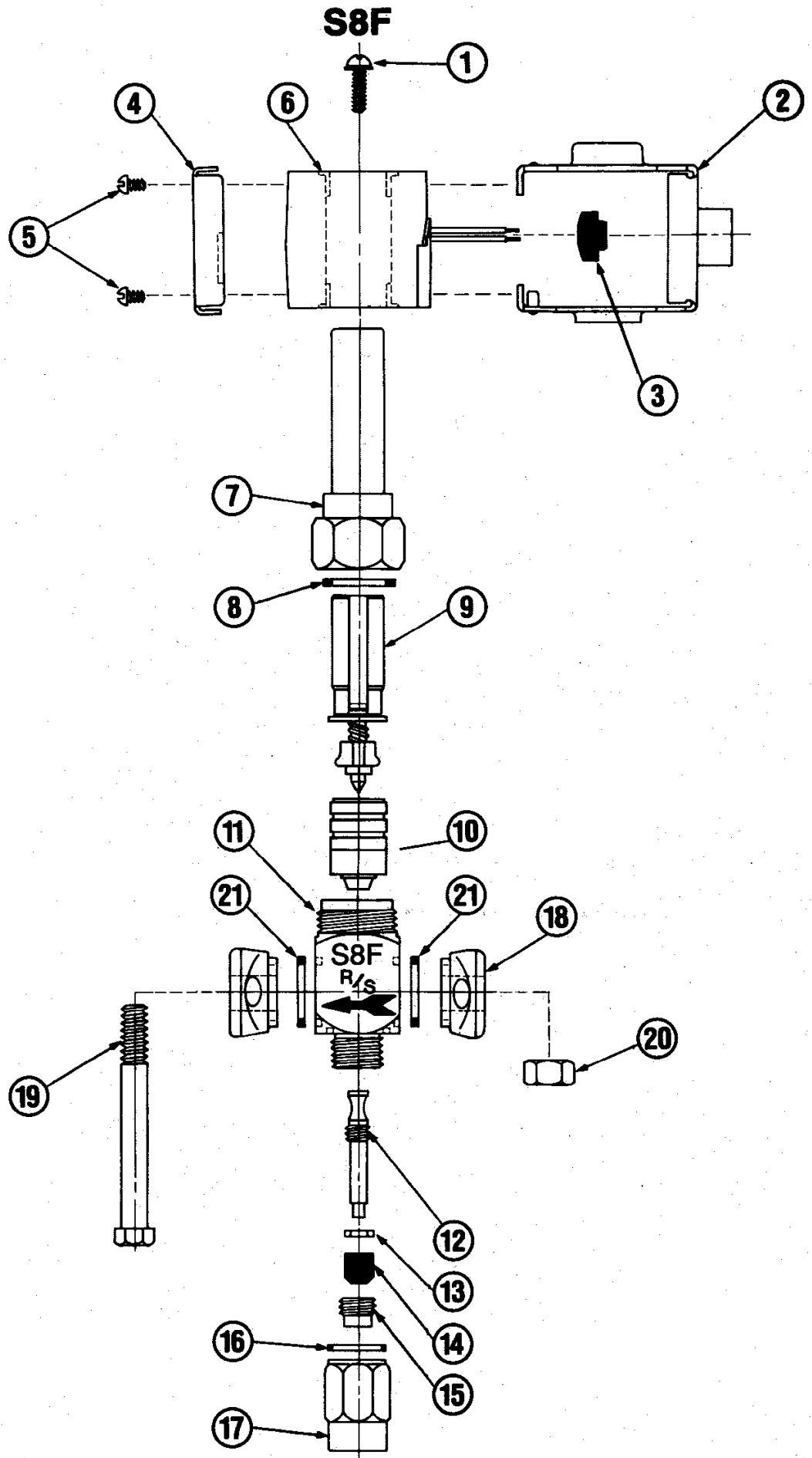

Installation

Protect inside of valve from dirt, chips and moisture during installation. Mount only in horizontal pipe line with solenoid coil at the top; this valve will work properly only in this position. In a liquid line the Solenoid Valve should be near the expansion valve inlet. It is advisable to install the S8F's close coupled companion strainer ahead of the valve for protection against dirt and chips.

The S8F solenoid valve must be installed with the arrow on the valve body in the direction of flow through the valve. If the valve is backwards, the flow will not be stopped when the valve is electrically de-energized. Like all Solenoid Valves, the S8F can stop flow only in the direction from normal inlet to normal outlet (as shown by the arrow on the body). If reversal of pressure occurs in the system so the outlet pressure exceeds the inlet pressure by more than 0.07 bar (1 psi) the piston will be blown upward from its seat and reverse flow will occur. If a system has this type of pressure reversal (as encountered during hot gas defrost with liquid recirculation systems), a check valve such as Refrigerating Specialties Division Type CK4A in series with the solenoid valve will prevent flow reversal. (CK4A must be installed downstream to avoid trapping liquid.)

Electrical

The Refrigerating Specialties Division molded water resistant Class "B" solenoid coil is designed for long life and powerful opening force. The standard coil housing meets NEMA 3R and 4 requirements. This sealed construction can withstand direct contact with moisture and ice. The coil housing far exceeds the requirements of NEMA Standard ICS, 1-110.57 salt spray test for rust resistance.

By definition, Class "B" coil construction will permit coil temperatures, as measured by resistance method, as high as 130°C (266°F). Final coil temperatures are a function of both fluid and ambient temperatures. The higher fluid temperatures require lower ambient temperatures so the maximum coil temperature is not exceeded. Conversely, low fluid temperatures permit higher ambient temperatures.

The molded Class "B" coil is available from stock with most standard voltages. However, coils are available for other voltages and frequencies, as well as for direct current. Coils are also available as transformer type with a 6 volt secondary winding for use with the Refrigerating Specialties Division Pilot Light Assembly (see current copy of Bulletin 60-10, "Pilot Light Assembly and Solenoid Transformer Coil").

The solenoid coil must be connected to electrical lines with volts and Hertz same as stamped on coil. The supply circuits must be properly sized to give adequate voltage at the coil leads even when other electrical equipment is operating. The coil is designed to operate with line voltage from 85% to 110% of rated coil voltage. Operating with a line voltage above or below these limits may result in coil burn-out. Also, operating with line voltage below the limit will definitely result in lowering the valve opening pressure differential. Power consumption during normal operation will be 33 watts or less.

Inrush and running current is listed below:

| Standard Coil Volts/Hertz | Part Number | Inrush Current (Amps) | Running Current (Amps) | Fuse Size (Amps) |
|------------------------------|----------------|-----------------------------|------------------------------|------------------------|
| 120/60 (Blue leads) | 201401 | 1.60 | 0.52 | 1 |
| 208/60 (Blue & Red leads) | 201405 | 0.88 | 0.28 | 1 |
| 240/60 (Red leads) | 201402 | 0.86 | 0.26 | 1 |
| 440/60 (Yellow & Red leads) | 201411 | 0.39 | 0.13 | 1 |
| 115/50 (Yellow & Blue leads) | 201409 | 1.50 | 0.46 | 1 |
| 230/50 (Yellow leads) | 201406 | 0.92 | 0.26 | 1 |
| Other | | (Contact Factory) | | |

On transformer coil the 6 volt leads are always black.

Service Pointers

The S8F Solenoid Valve and Strainer are easily removable for cleaning or repairing. To remove valve and strainer, merely unscrew the flange bolts and spread the flanges slightly apart.

1. **Failure to Open:** (a) Coil is of incorrectly high voltage. See "Electrical." Check Voltage printed on the coil. (b) Line voltage is abnormally low. See "Electrical." Check line voltage at coil leads with a voltmeter. (c) Failure to electrically energize. Check control circuit. (d) Pressure difference across valve is too high. The S8F will open against a maximum pressure difference across the valve of 21 bar (300 psig). (e) Solenoid Coil is burned-out. See "Electrical," and replace with proper coil. (f) #10 Piston Plug Assembly is sticking. To disassemble the S8F for inspection of internal parts (after pumping out the system as required); disconnect power source to #6 Solenoid Coil, remove #7 Tube Assembly,

lift out #9 Plunger Needle Assembly, then remove #10 Plug Assembly. Remove every trace of dirt from the piston and cylinder using fine emery cloth to remove burrs if necessary. Thoroughly clean all parts and reassemble using a light film of refrigeration oil on the Piston.

2. **Failure to Close:** (a) Electrical control circuit is not opening properly. Check wiring and controls. (b) There are chips or dirt on the Pilot Seat or the Main Valve Disc (both in #10 Piston Plug Assembly), preventing proper seating. Disassemble and clean Valve as outlined in (1f) above. (c) Main Valve Disc, Pilot Seat, or Valve Needle may be worn or damaged and therefore leaking. Disassemble and clean Valve as outlined in (1f) above. If any of these parts need replacing, it is advisable to replace using #8-10 Plunger Piston Kit. (d) #10 Piston Plug is sticking. See (1f) above. (e) #12 Manual Opening Stem is turned all or partly in, holding #10 Piston Plug Assembly open and permitting flow through the valve. (f) #1 Coil Housing Screw (made of non-magnetic stainless steel) has been replaced with a screw made of magnetic material and residual magnetism is holding #9 Plunger Needle Assembly in the open position. Consequently, the Main Valve is not closing. Replace with screw of correct material.

3. **Leakage Through Valve:** See (2) above.

4. **Overheating:** The Solenoid Coil is designed to operate hot and is constructed of high temperature materials accordingly. Unless troubled with actual Coil burn-outs, high coil temperature should be ignored. Persistent burn-outs indicate improper line or coil voltage. See (1e) above.

Warranty

All Refrigerating Specialties Products are warranted against defect in workmanship and materials for a period of one year from date of shipment from factory. This warranty is in force only when products are properly installed, field assembled, maintained, and operated in use and service as specifically stated in Refrigerating Specialties Catalogs or Bulletins for normal refrigeration applications, unless otherwise approved in writing by Refrigerating Specialties Division. Defective products, or parts thereof, returned to the factory with transportation charges prepaid and found to be defective by factory inspection will be replaced or repaired at Refrigerating Specialties' option, free of charge, F.O.B. factory. Warranty does not cover products which have been altered or repaired in the field; damaged in transit, or have suffered accidents, misuse, or abuse. Products disabled by dirt, or other foreign substances will not be considered defective.

THE EXPRESS WARRANTY SET FORTH ABOVE CONSTITUTES THE ONLY WARRANTY APPLICABLE TO REFRIGERATING SPECIALTIES PRODUCTS, AND IS IN LIEU OF ALL OTHER WARRANTIES, EXPRESS OR IMPLIED, WRITTEN OR ORAL, INCLUDING ANY WARRANTY OF MERCHANTABILITY, OR FITNESS FOR A PARTICULAR PURPOSE. No employee, agent, dealer or other person is authorized to give any warranties on behalf of Refrigerating Specialties, nor to assume, for Refrigerating Specialties, any other liability in connection with any of its products.

Safe Operation (see also Bulletin RSB)

People doing any work on a refrigeration system must be qualified and completely familiar with the system and the Refrigerating Specialties Division valves involved, or all other precautions will be meaningless. This includes reading and understanding pertinent Refrigerating Specialties Division product Bulletins, and Safety Bulletin RSB prior to installation or servicing work.

Where cold refrigerant liquid lines are used, it is necessary that certain precautions be taken to avoid damage which could result from liquid expansion. Temperature increase in a piping section full of solid liquid will cause high pressure due to the expanding liquid which can possibly rupture a gasket, pipe or valve. All hand valves isolating such sections should be marked, warning against accidental closing, and must not be closed until the liquid is removed. Check valves must never be installed upstream of solenoid valves, or regulators with electric shut-off, nor should hand valves upstream of solenoid valves or downstream of check valves be closed until the liquid has been removed. It is advisable to properly install relief devices in any section where liquid expansion could take place.

Avoid all piping or control arrangements which might produce thermal or pressure shock.

For the protection of people and products, all refrigerant must be removed from the section to be worked on before a valve, strainer, or other device is opened or removed.

Flanges with ODS connections are not suitable for ammonia service.

Solenoid Valve

Type S7A

Port Size: 20-25mm (3/4-1")

For Ammonia, R-12, R-22, R-502,
and other common Refrigerants.

Features

- Standard Coil Housing Meets NEMA 3R and NEMA 4—Rain Tight
- Coil Housing Surpasses NEMA Salt Spray Test
- Molded Class "B" Coil Construction
- Pilot Light Available
- Stainless Steel Needle
- Manual Opening Stem
- MOPD and MRP: 21 bar (300 PSIG)
- Positive Lift, Held Open Electrically

Description

This heavy duty solenoid valve is suitable for Ammonia, R-12, R-22, and R-502, other refrigerants, certain oils and other fluids approved for use in refrigeration. The S7A is a pilot operated, positive lift, cast iron bodied valve. The valve may be opened by means of the manual opening stem for servicing or in case of electrical power failure.

The Type S7A Solenoid Valve is furnished with FPT: Internal NPT (U.S. Standard Taper Pipe Thread), Socket Weld, Weld Neck or ODS (solders over copper tubing of given diameter) connections. The valve may be easily removed from between the flanges for servicing.

It is advisable to install a strainer upstream of each valve to prevent entrance of foreign material into the valves and the rest of the system. Refrigerating Specialties strainers are available to close-couple to valve inlets.

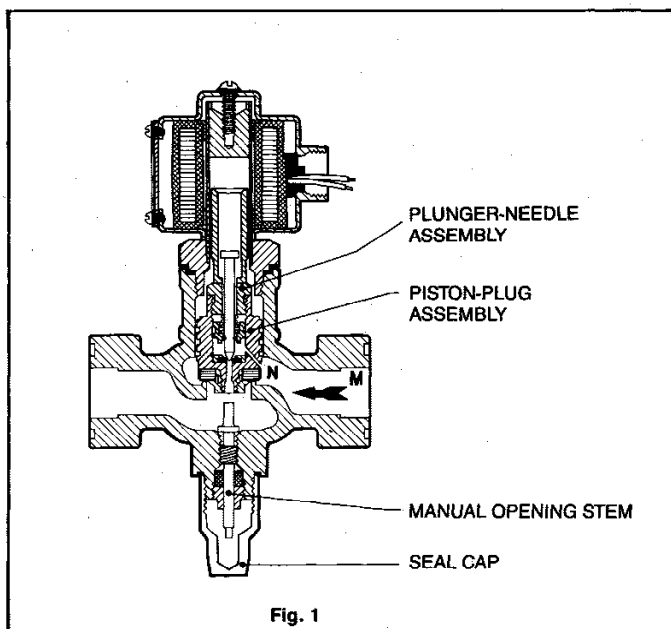
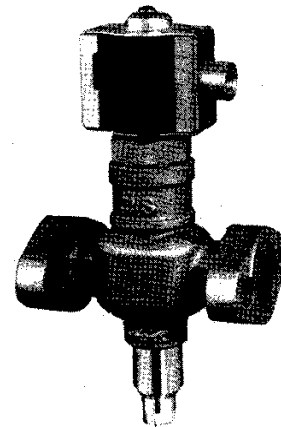

Fig. 1

Bulletin 30-92B
Type S7A



February 1991
Installation, Service and Parts Information

Purpose

Type S7A is a very versatile valve that may be used in most liquid, hot gas, or suction lines. This valve is also suited for applications requiring no pressure drop to hold the valve open.

Principles of Operation

The Type S7A is a pilot operated, positive lift, solenoid valve. Operation is as follows: The valve, in its closed position, with the solenoid coil de-energized and the plunger needle in its seated position, is shown in Figure 1. Electrical energization of the solenoid coil forms a magnetic field pulling up the plunger which strikes the needle, lifting it off its seat. This permits flow of the trapped refrigerant from the top of the piston which reduces pressure above the piston. The piston is then forced upward by the upstream pressure acting on the piston-main valve. This opens the valve port to allow flow through the valve. The piston-main valve is then held up magnetically by the plunger-needle assembly and no pressure drop is required to keep the valve open. If no pressure difference across the valve is present when the solenoid coil is energized, the piston-main valve is lifted off the seat by the plunger-needle assembly, opening the valve.

De-energization of the solenoid coil permits the spring-assisted needle to drop back into its seat, stopping the flow through the pilot port. The pressure above and below the piston-main valve is equalized through the bleed hole in the piston. The weights of the plunger-needle and the piston-main valve assembly cause the piston-main valve to drop to its seat and stop the flow. The pressure difference across the valve, acting upon the area of the valve seat, holds the piston-main valve in a tightly closed position.

Manual Opening Stem

The manual opening stem on the Type S7A is for the purpose of opening the valve without energizing the solenoid coil. Refer to the exploded view and parts list for location of the stem and other related parts. For access to the stem the seal cap on the bottom of the valve must be removed. This must be done with caution as refrigerant may have been trapped inside the seal cap. Manual opening is accomplished by turning the stem clockwise until only the flats on the end of the stem protrude from the packing nut. To reset for automatic operation turn the stem counterclockwise as far as it goes.

| REPAIR KITS FOR TYPE S7A SOLENOID VALVE | | | | |
|---|---------------------|------|---------------------|-----------|
| Item No. | Description | Qty. | 20mm (3/4") | 25mm (1") |
| 1 | Screw, Pan Hd. | 2 | | |
| 3 | Cover | 1 | | |
| 4 | Coil Asm. | 1 | See Part No. Page 4 | |
| 5 | Screw, Rd. Hd. | 1 | | |
| 6 | Housing Asm. | 1 | | |
| 7 | Bushing, Seal | 1 | | |
| 1,3,5,6,7 | Housing Kit | | 201629 | |
| 33 | Tub Asm. | 1 | | |
| 34 | Gasket | 1 | | |
| 35 | Plunger Asm. | 1 | | |
| 36 | Plug Asm. | 1 | | |
| 33,34 | Tube Kit | | 201042 | |
| 34,35,36 | Plug/Plunger Kit | | 201014 | 201012 |
| 37 | Man. Open Stem | 1 | | |
| 22 | Flat Washer | 1 | | |
| 23 | Packing, Stem | 1 | | |
| 22,23,34,37 | Opening Stem Kit | | 201142 | |
| 24 | Nut, Packing | 1 | | |
| 22,23,24 | Stem Pkg. Kit | | 202100 | |
| 25 | Gasket | 1 | | |
| 27 | Seal Cap | 1 | | |
| 25,27 | Seal Cap Kit | | 202110 | |
| 28 | Flange Gasket Pkg. | 12 | | 202079 |
| 25,28,34 | S7A Gasket Kit | | 202286 | |
| 34 | Gasket Pkg, SolTube | 5 | | 202405 |

DIMENSIONAL DATA

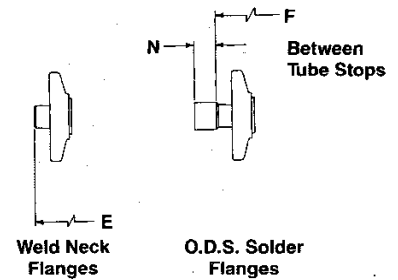
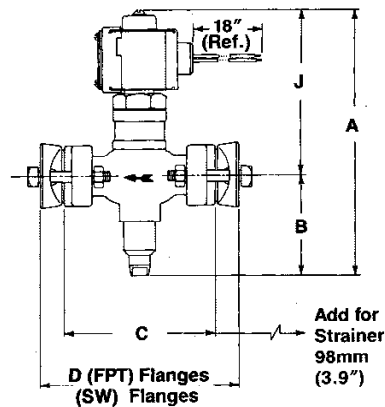
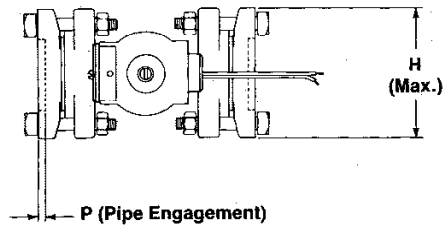

Allow 100mm (4") above valve for removal of coil housing assembly.

Allow 25mm (1") below valve to operate manual opening stem.

| A | | B | | C | | D (FPT, SW) | | E (WN) | | F (ODS) | | H | | J | | N (ODS) | | P (SW) | |
|------|------|-----|------|------|------|-------------|------|--------|------|---------|------|-----|------|-----|------|---------|------|--------|------|
| MM | INCH | MM | INCH | MM | INCH | MM | INCH | MM | INCH | MM | INCH | MM | INCH | MM | INCH | MM | INCH | MM | INCH |
| 282. | 11.1 | 102 | 4.0 | 157. | 6.2 | 216 | 8.5 | 261 | 10.3 | 239 | 9.4 | 117 | 4.6 | 180 | 7.1 | 25 | 1.0 | 13 | .5 |

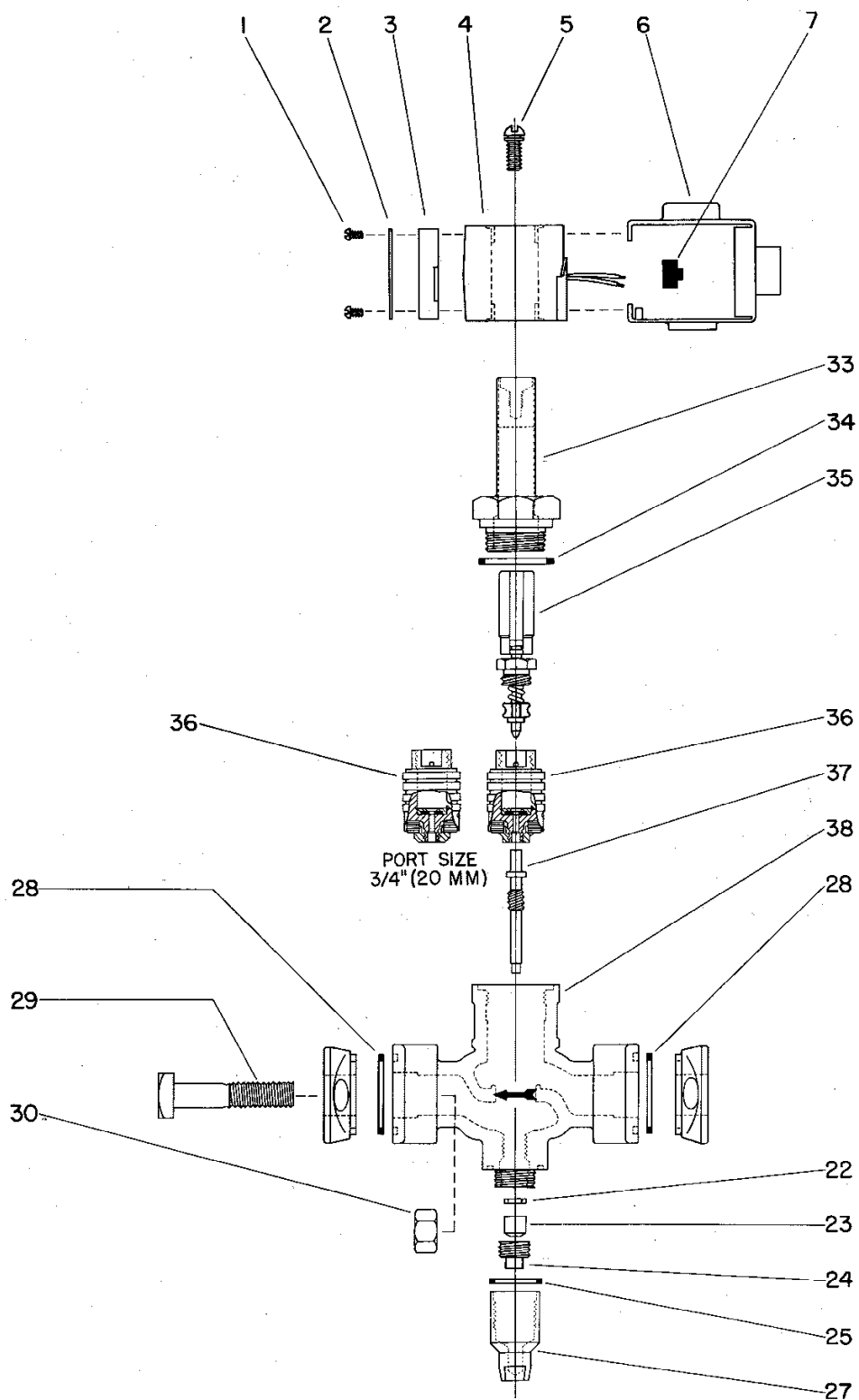

S7A
 20-25mm (3/4-1")

Installation

Protect inside of valve from dirt, chips and moisture during installation. Mount only in horizontal pipe line with solenoid coil at the top; this valve will work properly only in this position. In a liquid line the Solenoid Valve should be near the expansion valve inlet. It is advisable to install the S7A's close coupled companion strainer ahead of the valve for protection against dirt and chips.

The S7A solenoid valve must be installed with the arrow on the valve body in the direction of flow through the valve. If the valve is backwards, the flow will not be stopped when the valve is electrically de-energized. Like all Solenoid Valves, the S7A can stop flow only in the direction from normal inlet to normal outlet (as shown by the arrow on the body). If reversal of pressure occurs in the system so the outlet pressure exceeds the inlet pressure the piston will be blown away from its seat and reverse flow will occur. If a system has this type of pressure reversal (as encountered during hot gas defrost with liquid recirculation systems), a check valve such as Refrigerating Specialties Division Type CK4A in series with the solenoid valve will prevent flow reversal. (CK4A must be installed downstream to avoid trapping liquid.)

Electrical

The Refrigerating Specialties Division molded water resistant Class "B" solenoid coil is designed for long life and powerful opening force. The standard coil housing meets NEMA 3R and 4 requirements. This sealed construction can withstand direct contact with moisture and ice. The coil housing far exceeds the requirements of NEMA Standard ICS, 1-110.57 salt spray test for rust resistance.

By definition, Class "B" coil construction will permit coil temperatures, as measured by resistance method, as high as 130°C (266°F). Final coil temperatures are a function of both fluid and ambient temperatures. The higher fluid temperatures require lower ambient temperatures so the maximum coil temperature is not exceeded. Conversely, low fluid temperatures permit higher ambient temperatures.

The molded Class "B" coil is available from stock with most standard voltages. However, coils are available for other voltages and frequencies. Coils are also available as transformer type with a 6 volt secondary winding for use with the Refrigerating Specialties Division Pilot Light Assembly (see current copy of Bulletin 60-10, "Pilot Light Assembly and Solenoid Transformer Coil").

The solenoid coil must be connected to electrical lines with volts and Hertz same as stamped on coil. The supply circuits must be properly sized to give adequate voltage at the coil leads even when other electrical equipment is operating. The coil is designed to operate with line voltage from 85% to 110% of rated coil voltage. Operating with a line voltage above or below these limits may result in coil burn-out. Also, operating with line voltage below the limit will definitely result in lowering the valve opening pressure differential. Power consumption during normal operation will be 33 watts or less.

Inrush and running current is listed below:

| Standard Coil Volts/Hertz | Part Number | Inrush Current (Amps) | Running Current (Amps) | Fuse Size (Amps) |
|------------------------------|----------------|-----------------------------|------------------------------|------------------------|
| 120/60 (Blue leads) | 201401 | 1.60 | 0.52 | 1 |
| 208/60 (Blue & Red leads) | 201405 | 0.88 | 0.28 | 1 |
| 240/60 (Red leads) | 201402 | 0.86 | 0.26 | 1 |
| 440/60 (Yellow & Red leads) | 201411 | 0.39 | 0.13 | 1 |
| 115/50 (Yellow & Blue leads) | 201409 | 1.50 | 0.46 | 1 |
| 230/50 (Yellow leads) | 201406 | 0.92 | 0.26 | 1 |
| Other | | (Contact Factory) | | |

On transformer coil the 6 volt leads are always black.

Service Pointers

The S7A Solenoid Valve and Strainer are easily removable for cleaning or repairing. To remove valve and strainer, first manually open the valve and pump out the refrigerant in the section of the line sealed off. Then unscrew the flange bolts and spread the flanges slightly apart.

1. Failure to Open: (a) Coil is of incorrectly high voltage. See "Electrical." Check voltage printed on the coil. (b) Line voltage is abnormally low. See "Electrical." Check line voltage at coil leads with a voltmeter. (c) Failure to electrically energize. Check control circuit. (d) Pressure difference across valve is too high. The S7A will open against a maximum pressure difference across the valve of 21 Kg/cm² (300 psig). (e) Solenoid Coil is burned-out. See "Electrical," and replace with proper coil. (f) Plug Plunger Assembly is sticking. To disassemble the S7A for inspection of internal parts (after pumping

out the system as required); disconnect power source to Solenoid Coil, remove Tube Assembly, lift out Plug Plunger Assembly. Remove every trace of dirt from the piston and cylinder using fine emery cloth to remove burrs if necessary. Thoroughly clean all parts and reassemble using a light film of refrigeration oil on the Piston.

2. Failure to Close: (a) Electrical control circuit is not opening properly. Check wiring and controls. (b) There are chips or dirt on the Plug Plunger Seat, preventing proper seating. Disassemble and clean Valve as outlined in (1f) above. (c) Main Valve Disc, Pilot Seat, or Valve Needle may be worn or damaged and therefore leaking. Disassemble and clean Valve as outlined in (1f) above. If any of these parts need replacing, it is advisable to replace Plug Plunger Kit. (d) Piston Plug is sticking. See (1f) above. (e) Manual Opening Stem is turned all or partly in, holding Piston Plug Assembly open and permitting flow through the valve. (f) #5 Coil Housing Screw (made of non-magnetic stainless steel) has been replaced with a screw made of magnetic material and residual magnetism is holding Plunger Needle Assembly in the open position. Consequently, the Main Valve is not closing. Replace with screw of correct materials.

3. Leakage Through Valve: See (2) above.

4. Overheating: The Solenoid Coil is designed to operate hot and is constructed of high temperature materials accordingly. Unless troubled with actual coil burn-outs, high coil temperature should be ignored. Persistent burn-outs indicate improper line or coil voltage. See (1e) above.

Warranty

All Refrigerating Specialties Products are warranted against defect in workmanship and materials for a period of one year from date of shipment from factory. This warranty is in force only when products are properly installed, field assembled, maintained and operated in use and service as specifically stated in Refrigerating Specialties Catalogs or Bulletins for normal refrigeration applications, unless otherwise approved in writing by Refrigerating Specialties division. Defective products, or parts thereof, returned to the factory with transportation charges prepaid and found to be defective by factory inspection will be replaced or repaired at Refrigerating Specialties option, free of charge, F.O.B. factory. Warranty does not cover products which have been altered or repaired in the field; damaged in transit, or have suffered accidents, misuse, or abuse. Products disabled by dirt, or other foreign substances will not be considered defective.

THE EXPRESS WARRANTY SET FORTH ABOVE CONSTITUTES THE ONLY WARRANTY APPLICABLE TO REFRIGERATING SPECIALTIES PRODUCTS, AND IS IN LIEU OF ALL OTHER WARRANTIES. EXPRESS OR IMPLIED, WRITTEN OR ORAL, INCLUDING ANY WARRANTY OF MERCHANTABILITY, OR FITNESS FOR A PARTICULAR PURPOSE. No employee, agent, dealer or other person is authorized to give any warranties on behalf of Refrigerating Specialties, nor to assume, for Refrigerating Specialties, any other liability in connection with any of its products.

Safe Operation (see also Bulletin RSB)

People doing any work on a refrigeration system must be qualified and completely familiar with the system and the Refrigerating Specialties Division valves involved, or all other precautions will be meaningless. This includes reading and understanding pertinent Refrigerating Specialties Division product Bulletins, and Safety Bulletin RSB prior to installation or servicing work.

Where cold refrigerant liquid lines are used, it is necessary that certain precautions be taken to avoid damage which could result from liquid expansion. Temperature increase in a piping section full of solid liquid will cause high pressure due to the expanding liquid which can possibly rupture a gasket, pipe or valve. All hand valves isolating such sections should be marked, warning against accidental closing, and must not be closed until the liquid is removed. Check valves must never be installed upstream of solenoid valves, or regulators with electric shut-off, nor should hand valves upstream of solenoid valves or downstream of check valves be closed until the liquid has been removed. It is advisable to properly install relief devices in any section where liquid expansion could take place.

Avoid all piping or control arrangements which might produce thermal or pressure shock.

For the protection of people and products, all refrigerant must be removed from the section to be worked on before a valve, strainer, or other device is opened or removed.

Flanges with ODS connections are not suitable for ammonia service.

SAFETY PROCEDURES FOR REFRIGERATING SPECIALTIES REFRIGERATION CONTROL VALVES

REFRIGERATING SPECIALTIES DIVISION
SAFETY BULLETIN RSB
EXPIRATION DATE DECEMBER 31, 1993

INTRODUCTION

This bulletin is a summary of safety procedures for the proper selection, installation, use and maintenance of Refrigerating Specialties Division industrial refrigerant control valves. Additional free copies are available and should be distributed to all concerned personnel. This bulletin is intended to help you protect your personnel, product and plant. Because of space limitations, this bulletin must be supplemented by accepted and known industry safety practices and local code requirements.

Refrigerating Specialties Division control valves are designed and built to the highest standards of the refrigeration industry. However, for proper performance the valves must be correctly chosen, properly installed and periodically serviced. Because safe operation is of primary concern, this bulletin emphasizes suggestions for the safe installation and maintenance of Refrigerating Specialties Valves. Read this information carefully before installing a valve or working on one already installed; also, use it to review all previous installations.

All personnel working on valves must be qualified to work on refrigeration systems. Any person intending to service a valve should completely read this bulletin and the bulletin describing the particular valve and its operation before any work begins. If there are any questions, contact Refrigerating Specialties before proceeding with the work.

Caution: Do not, at any time, make any alteration or modifications to any Refrigerating Specialties Division valves or regulators without the express and written approval of this company. Threaded parts should not be subjected to excessive torque by use of an oversized wrench, wrench extension or by impacting the wrench handle. Where specified in the individual bulletin, observe the torque requirements for bolts, screws and other threaded parts. Contact the factory for torque values not furnished in current literature.

For extensive repairs on valves or regulators, especially those more than three years old, the valves or regulators should be returned to the factory for thorough inspection and rebuilding. Spare parts should be checked for corrosion before installation. In addition, part numbers should be checked against the latest assembly bulletin to be sure current parts are being used.

If a valve or regulator has failed under circumstances which caused, or could have caused, injury to personnel or damage to property, a replacement valve should not be installed until the reason for the previous failure is determined and corrected. Adequate protection should be taken to prevent both liquid shock and suction shock both upstream and downstream of the valve or regulator.

LIQUID EXPANSION

In liquid lines, or lines that might contain substantial amounts of liquid refrigerant, certain precautions must be taken to avoid damage due to liquid expansion when a section of line is isolated by positive shut off valves. This condition may occur whenever the ambient temperature could be higher than the liquid temperature. This could even occur in a refrigerant or oil line other than a "liquid" line.

Temperature increase in a section with trapped liquid can cause extremely high pressures due to the expanding liquid and possibly rupture a gasket, pipe, or valve. When low temperature liquid lines are used, as in a liquid overfeed (recirculation) system, and the lines or control valves may be exposed to warm ambient conditions, particular care must be taken; liquid expansion can occur very rapidly.

CHECK VALVES

Check valves must never be installed at the inlet of either a solenoid valve, or a regulator with an electric solenoid pilot shut-off feature. Also, the check valve should not be installed at the inlet of an outlet pressure regulator in a system where liquid may be trapped between the two valves. If a check valve is needed, install it on the outlet side of such valves. Most solenoid valves and regulators will permit reverse flow if the outlet pressure is greater than inlet pressure. If at any time, such reverse pressure conditions are possible and reverse flow is unacceptable a check valve should be installed at the control valve outlet.

HAND VALVES

All hand valves that could trap liquid when closed must be marked with a warning against accidental closing. The liquid refrigerant must be removed before the hand valves are closed on both sides of a control valve or any other component. Also, liquid must be removed before a hand valve is closed at the inlet of a solenoid valve or a regulator with positive electric shut-off, or some outlet pressure regulators, or at the outlet of a check valve, unless these valves are manually open.

Caution: To protect personnel, product and plant, remove all liquid from the section to be isolated before hand valves are closed. Make sure the control valves are open when removing the liquid. See Service and Maintenance Instructions before attempting to take any valve apart.

RELIEF DEVICES

Relief devices or relief methods should be used in all parts of a refrigeration system where liquid can be trapped and liquid expansion could take place. Under no circumstances should R/S Pressure Regulators be used as a relief to the atmosphere, R/S Type H Safety Relief valves should be used instead.

SELECTION AND APPLICATION

A control valve must be selected only by a person having adequate knowledge of the system and of the valve to be chosen. Any Refrigerating Specialties Division control valve must be used only as specifically stated in Refrigerating Specialties Division Catalogs or Bulletins for normal refrigeration applications unless otherwise approved in writing by Refrigerating Specialties Division.

INSTALLATION

Installation must be done according to all applicable Safety Codes and Standards, and by personnel qualified to install refrigeration systems. Refrigerating Specialties Division control valves must be installed according to the manufacturer's instructions, this bulletin, and the generally known safety practices.

MOUNTING

Allow proper space for installing the valve. Do not use the valve to "stretch" or "align" the pipe. Using flange bolts to close a large gap can distort the valve or at least stress it unduly, and possibly cause it to malfunction, or the bolts may be damaged or stripped. (See table below for proper torque requirements). For proper sealing the gaskets should be lightly oiled and all bolts must be tightened evenly. Make sure the flange tongues are properly aligned with the grooves in the valve body. Where necessary, support the valves by brackets or hangers to avoid overstressing the pipe or valve.

| TORQUE REQUIREMENTS FOR FLANGE BOLTS | | |
|--------------------------------------|--|--------------------------|
| Bolt Diameter | Used on Valve Port Size | Torque |
| 7/16" (11 mm)* | 5-13 mm (3/16"-1/2") | 3.9 mkg (28 ft. lb.) |
| 5/8" (16 mm) | 20-25 mm (3/4"-1") 32-50 mm (1 1/4"-2") | 11.8 mkg (85 ft. lb.) |
| 3/4" (19 mm) | 65-75 mm (2 1/2"-3") | 14.5 mkg (105 ft. lb.) |
| 7/8" (22 mm) | 100 mm (4") | 22.1 mkg (160 ft. lb.) |

*All A2 direct operated regulators, and AFR-3 and FFR flow regulators use 7/16" diameter bolts.

LOCATION

Valves must not be installed in locations where they can be damaged by material handling or other equipment. Trapped ice build-up must be avoided at or between valves and other equipment. Provide reasonable access to all control valves for maintenance purposes.

Float switches must be mounted so vibration effects on the switch mechanism are minimized. Failure to protect switch from excessive vibration could shorten life and cause premature failure.

INSULATION

When it is necessary to insulate the control valves, the insulation must be applied to allow proper operation and maintenance of the valves. The manual opening and adjusting stems should be easily accessible at all times. In the case of solenoid valves the insulation must not extend to the coil housing or coil burnout may occur. Insulation should be constructed so that sections can be easily removed and replaced to allow the valve to be disassembled. Insulation applied to strainers should provide ready access for cleaning the strainer.

Refrigerating Specialties Division

Parker Hannifin Corporation
Refrigerating Specialties Division
2445 South 25th Avenue
Broadview, IL 60153-3891

Telephone: (708) 681-6300
FAX: (708) 681-6306
Telex: 728462 RESPEC BRDV



Since most maintenance problems caused by dirt occur at the start-up of a system, it is advisable to delay insulating the control valves and strainers until the system has operated for several days. During that time the strainers should be checked for dirt and cleaned as necessary. Cotton bags are available for 25mm-100mm (1" - 4") Type RSF Strainers to improve their ability to remove small particles of dirt during start-up.

PUMP OUT MEANS

Individual valves or control stations should be provided with means for pumping out or safely purging the refrigerant.

DIRT AND CORROSION

Protect the valves from foreign material during storage and installation. The protective plugs on the valve openings should remain in place until the valves are ready to be installed. Once a section of a system is installed, and before it is put into operation, it is advisable to charge it with proper refrigerant or suitable inert gas to avoid corrosion. External corrosion over a long period of time must be controlled by painting and replacement of corroded parts.

PRESSURE TESTING

Every segment of a refrigeration system, including control valves, should be field pressure tested before system is insulated and put in use. Make sure that correct high and low side test pressures are used. Use proper refrigerant or gas for pressure testing; that is do not use halocarbons or CO₂ to test an ammonia system, nor use ammonia to test halocarbon system. Never use the compressor in a system to build up pressure for testing.

In pressure testing Range V, VA, A, B or D pressure regulators, test pressure in excess of 21. kg/cm² (300 psig) may cause setting shift and diaphragm may deform enough to require replacement after the test. If the above conditions exist, contact the factory for proper solution.

ELECTRICAL

Only properly qualified electricians should handle the electrical portions of control valves and their circuitry. All power supplies and wiring must be adequate to provide the proper voltage and current to the solenoid coils. The power supply must be capable of providing the proper in-rush current. Never energize the solenoid with the coil housing or plunger assembly removed.

SERVICE AND MAINTENANCE

All systems require maintenance and service. The personnel doing the work must be qualified and completely familiar with the system they are to work on or all other precautions will be meaningless.

PUMP OUT

For the protection of personnel, product, and plant, all refrigerant possible must be removed from a valve or any other component of the system, before any refrigerant retaining part is loosened. Before opening a valve, make sure all refrigerant liquid has been removed. In particular, beware of strainers and other sections of piping which may trap liquid refrigerant which will require a considerable length of time to remove. Pump out as much refrigerant as possible before discharging remaining refrigerant in a properly protected manner. During pump out make sure control valves are opened manually to avoid trapping refrigerant. All type RSF and RSW Strainers, except the 13mm (1/2"), are provided with 3/8" FPT connection to assist in pump out.

At times it may be necessary to discharge some small amount of refrigerant from the isolated section. When this becomes necessary, certain precautions must be observed. Make sure control of discharge rate can be easily maintained and that a quick shut-off is available.

Refrigerant should be discharged into and disposed of in a proper container accepted by applicable safety codes and standards. Discharge of refrigerant to atmosphere should be avoided. Never discharge any refrigerant into an area without sufficient ventilation, or into an area where open flame or electrical spark is present. Any oil in the refrigerant may cause a mist that could cause a fire or explosion.

Halocarbon refrigerant should not be discharged into areas where open flame is present, since toxic gases may form. Ammonia should not be discharged into occupied areas, or areas containing product affected by ammonia. In the case of ammonia, discharge any vapor left into a container of cold water,

making sure that the discharge hose remains submerged at all times. (Be sure that no pressure reversals can occur that may pull water into the system.) Water may have to be changed to absorb all the ammonia; about one gallon of fresh water is needed for one pound of ammonia.

To prevent pulling excessive air and moisture into a system, avoid opening the system when it is under vacuum.

Caution: Do not attempt to work on any part of a refrigeration system without having help nearby and observing. Use safety glasses or a safety face shield for added safety to protect the eyes. Protective equipment should be readily available and all personnel involved should be thoroughly trained in its use. Personnel should be especially protected against falling because they may be startled by escaping refrigerant. Always make sure that there is a way out and that everyone can leave the area fast. When seal caps cover manual opening or adjusting stems, the caps must be removed with caution because liquid refrigerant could accumulate under such a cap. Avoid contact with any liquid refrigerant.

ELECTRICAL

Before working on any valve or other item having electrical components refer to the "ELECTRICAL" paragraph of the "INSTALLATION" section. Be sure the circuits are completely de-energized; just throwing a switch may not be sufficient. Failure to do this may result in personal injury or damage to solenoid coils or other components. Take care to see that the circuits cannot be energized accidentally. Never energize the solenoid with the coil housing or plunger assembly removed.

DISASSEMBLY

Be sure that any person working on a valve is familiar with its construction and operation by referring to the proper bulletin. Make sure the pressure in the system to be opened is reduced to, and remains, at atmospheric pressure before opening the valve. A pressure gauge should be connected to the part of the system to be evacuated. Before removing the bonnet of pressure regulators, back out adjusting stem to prevent damage to the diaphragm.

RE-ASSEMBLY

Be sure all parts are clean and free of moisture before reassembly. Damaged parts and gaskets should be replaced. It is advisable to purge the section of air before opening it to the rest of the system. When opening hand valves, always open the valve to the inlet of the control valve first; this will avoid backflow and possible damage to the strainer if one is used.

STRAINER MAINTENANCE

Strainer inspection is of utmost importance, especially the first few hours, days or weeks after the start-up. The strainers should be opened and any foreign material removed. The screens should be washed with proper solvent. Strainer inspection and cleaning should be continued until dirt accumulation ceases. Later, any time a valve is opened for service or maintenance, its companion strainer should also be inspected and cleaned. Cotton bags are available for 25mm-100mm (1" - 4") Type RSF Strainers to improve their ability to remove small particles of dirt during start-up. If a strainer filter bag is used in the strainer basket, the cloth bag must be checked every few days depending upon the amount of system dirt collected. When the cloth bag no longer collects dirt, it must be discarded.

GENERAL SPECIFICATIONS

Refrigerating Specialties refrigerant containing valves and strainers are designed for a Maximum Rated Pressure of 21 bar (300 psig) except where shown otherwise on the nameplate. They are suitable for use under most temperature conditions encountered in refrigeration systems. Maximum and minimum fluid temperatures for each valve are published in R/S Condensed Catalog CC11a. If either fluid or ambient temperature is below a valves rated minimum, consult the factory. In addition, should fluid temperature exceed the rated maximum or should ambient temperatures exceed 125 F., consult the factory.

The valves are designed to operate with ammonia and/or halocarbon refrigerants. Valves using flanges with copper connections must not be used with ammonia refrigerant. Unless authorized by the factory, Refrigerating Specialties valves should not be used for refrigerants or fluids not mentioned on the nameplate or in the pertinent bulletin.

Refrigerating Specialties Division

Parker Hannifin Corporation
Refrigerating Specialties Division
2445 South 25th Avenue
Broadview, IL 60153-3891

Telephone: (708) 681-6300
FAX: (708) 681-6306
Telex: 728462 RESPEC BRDV



PRINTED IN U.S.A.

Refrigerant Strainer

Type RSF

Size: 13mm - 100mm (1/2" - 4")

For Ammonia, R-12, R-22, R-502
and other common Refrigerants

Features

- Stainless Steel (60 Mesh) Screen
- 3/8" FPT Drain Connection 20-100mm (3/4" - 4") for Safe Cleaning in Line
- Design Pressure (MRP) 21 bar (300 psig)
- Ample Screen Area
- Low Pressure Drop
- Can Be Close Coupled
- Durable Filter Bags Available 20-100mm (3/4" thru 4") to Aid System Clean-up

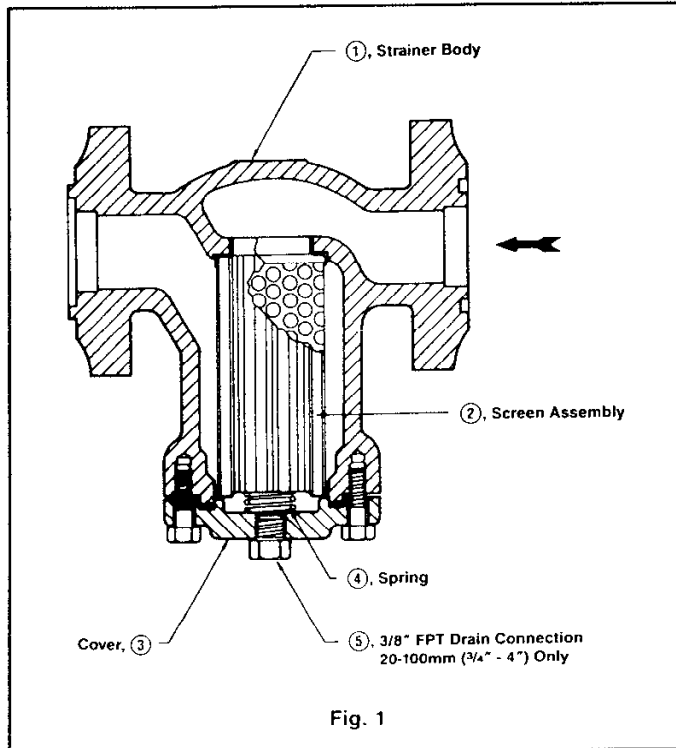

Description

These industrial type, semi-steel bodied Refrigerant Strainers with stainless steel screen are designed especially for the protection of R/S Control Valves from foreign materials present in refrigeration systems. The fine stainless screen mesh will collect particles as small as six thousandths of an inch in diameter. Generous available screen area allows maximum dirt capacity at minimum pressure drop. The strainers may be close coupled to R/S valves having the same flange gasket size.

Purpose

The RSF Refrigerant Strainers collect foreign materials and dirt present in a refrigeration system at minimal pressure drop in order

Bulletin 00-10E
Type RSF

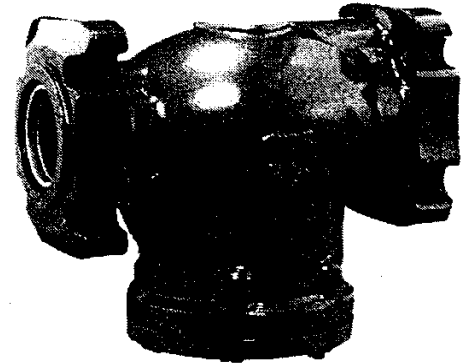

May 1991
Installation, Service and Parts Information

to minimize damage to or cause malfunction of control valves. This, of course, is extremely important upon start-up of a new refrigeration system where dirt, scale, and weld particles may be present in the system and are disturbed and circulated when air testing or upon system start-up. Also when an existing system is revised, any settled dirt or foreign matter may be disturbed and circulated throughout the system. If particles are too small to be removed by the strainer, it is suggested that a R/S Filter Bag be installed where applicable, periodically cleaned and removed when necessary. It is not safe to omit strainers ahead of the control valves unless there is a certainty that the system will always be clean.

Service Pointers

It is very important that the strainer is frequently inspected for dirt and cleaned during system start-up and until no further dirt is found.

Before beginning to loosen cover screws be sure that the strainer has been pumped out and any entrapped refrigerant liquid is properly removed. Then remove Screen Assembly #2 by removing Strainer Cover #3. The screen assembly should be washed with a good solvent and blown dry. The inside of the Strainer Body #1 should also be cleaned. Also check condition of cover gasket and replace if necessary.

After the strainer has been thoroughly inspected and cleaned, insert the screen assembly into the strainer body, making sure that it is properly centered to avoid crushing (and that the Spring #4 is properly located) and fasten the strainer cover in place. Cover bolts must be tightened evenly to the torque values shown.

COVER BOLT TORQUE REQUIREMENTS

| Strainer Size | Bolt Size | Torque |
|---------------|-----------|----------------------|
| 1-1 1/4 | 5/16 - 18 | 1.5 mkg (11 ft. lb.) |
| 2-4 | 3/8 - 16 | 2.8 mkg (20 ft. lb.) |

1/2 RSF Cover Torque: 8.3 mkg (60 ft. lb.)

Additional Service Pointers

1. Ruptured Screen Assembly: (a) Screen is clogged causing excessive pressure drop to rupture the screen—check and clean more frequently. (b) Fluid velocity too great. Use oversized strainer, or a restricting hand valve to reduce fluid flow.

(continued page 4)

REPAIR KITS FOR TYPE RSF STRAINER

| ITEM NO. | DESCRIPTION | QTY | 13mm (1/2") | 20-25mm (3/4-1") | 32mm (1 1/4") | 40-50mm (1 5/8-2") | 65mm (2 1/2") | 75mm (3") | 100mm (4") |
|----------|----------------------|-----|-------------|------------------|---------------|--------------------|---------------|-----------|------------|
| 2 | SCREEN ASSEMBLY | 1 | | | | | | | |
| 6 | SPRING | 1 | | | | | | | |
| 4 | GASKET | 1 | 303070 | 301585 | | 301688 | | 301690 | |
| 3 | COVER | 1 | | | | | | | |
| 2,4,3 | 1/2" SCREEN KIT | | 200136 | | | | | | |
| 2,4 | 3/4-1" SCREEN KIT | | | 200140 | | | | | |
| 2,6,4 | 1 1/4-4" SCREEN KIT | | | | 200142 | 200144 | 200146 | | 200148 |
| 5 | COVER BOLT PKG | 6 | N/A | 202248 | | | | | |
| | | 8 | N/A | | | | 202253 | | |
| 9 | FLANGE GASKET PKG | 12 | 202078 | 202079 | 202080 | 202081 | 202082 | 202083 | 202084 |
| 3,4,5 | 3/4-1 1/4" COVER KIT | | N/A | 200160 | | | | | |
| 3,4 | 1 5/8-4" COVER KIT | | | | | 200162 | | 200165 | |
| 4,10 | STRAINER BAG KIT | | N/A | 201701 | 201702 | 201703 | 202513 | | 202514 |

DIMENSIONAL TABLE

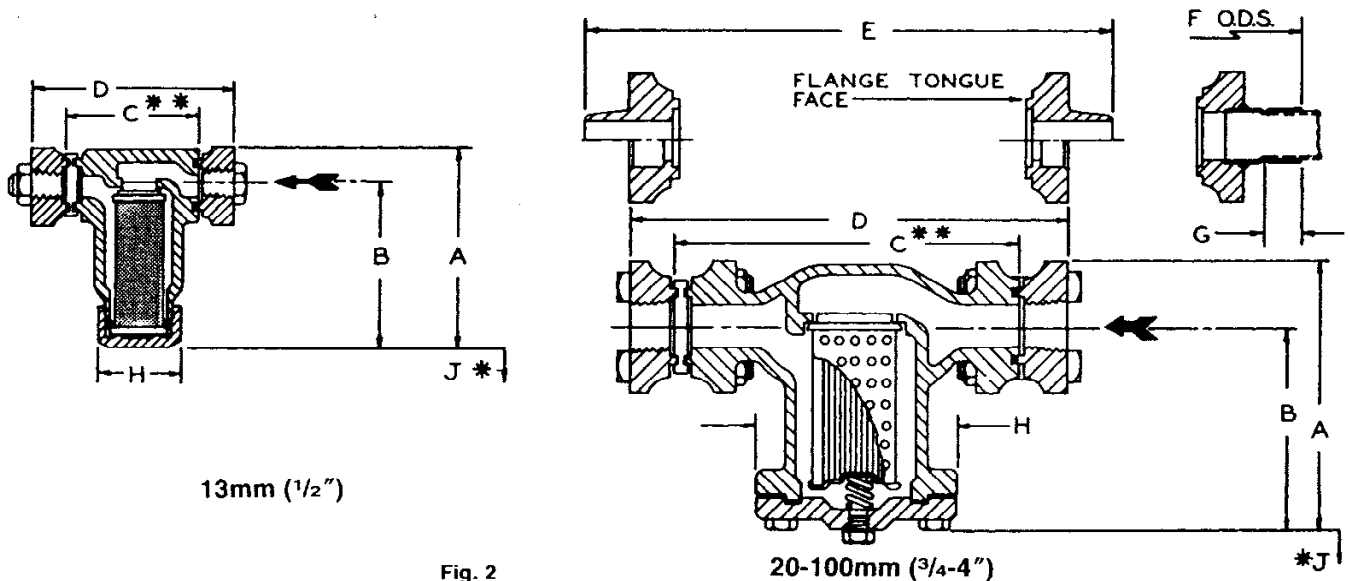
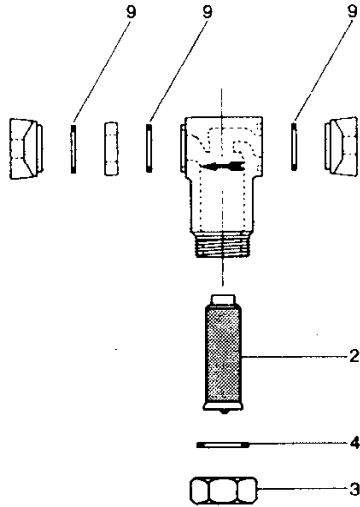

Fig. 2

*J dimension in space required for removal of Strainer Screen Assembly.

**DIMENSION C IS THE DISTANCE FROM ONE FLANGE TONGUE FACE TO THE OTHER. THIS IS THE SPACE BETWEEN THE FLANGES IN THE LINE TO ALLOW THE INSTALLATION OF THE STRAINER. WHEN CLOSE COUPLING STRAINER TO A VALVE, SUBTRACT 3mm (1/8") FOR STRAINER SIZES 13-100mm (1/2-4").

| STRAINER SIZE | | VALVE PORT SIZE | | A | | B | | C** | | D (FPT, SW) | | E (WN) | | ODS SIZE | F (ODS) | | G (ODS) | | H | | J* | | |
|---------------|-------|-----------------|-------|-------|-------|-------|------|-------|-------|-------------|-------|--------|-------|----------|---------|-------|---------|------|-------|------|-----|-----|------|
| mm | in. | mm | in. | mm | in. | mm | in. | mm | in. | mm | in. | mm | in. | in. | mm | in. | mm | in. | mm | in. | mm | in. | |
| 13 | 1/2 | 5 | 3/16 | 107 | 4.25 | 86 | 3.37 | 57 | 2.25 | 95 | 3.75 | 122 | 5.56 | 1/2 | 141 | 5.56 | 8.6 | 0.37 | 38 | 1.5 | 76 | 3 | |
| | | or | or | | | | | | | | | | | 13 | 1/2 | 148 | 5.81 | 13 | | | | | 0.50 |
| | | | | | | | | | | | | | | | | 173 | 6.81 | 19 | | | | | 0.75 |
| 25 | 1 | 20 | 3/4 | 141 | 5.56 | 111 | 4.37 | 98 | 3.87 | 152 | 6.0 | 141 | 7.75 | 7/8 | 216 | 8.5 | 19 | 0.75 | 95 | 3.75 | 127 | 5 | |
| | | or | or | | | | | | | | | | | 25 | 1 | 222 | 8.75 | 23 | | | | | 0.90 |
| | | | | | | | | | | | | | | | | 222 | 8.75 | 24 | | | | | 0.96 |
| | | | | | | | | | | | | | | | | 232 | 9.15 | 29 | | | | | 1.15 |
| 32 | 1 1/4 | 32 | 1 1/4 | 181 | 7.12 | 127 | 5.0 | 178 | 7.0 | 230 | 9.06 | 286 | 11.28 | 1 3/8 | 298 | 11.75 | 23 | 0.96 | 95 | 3.75 | 127 | 5 | |
| | | | | | | | | | | | | | | 1 3/8 | 313 | 12.31 | 29 | 1.15 | | | | | |
| | | | | | | | | | | | | | | 2 1/8 | 343 | 13.5 | 34 | 1.34 | | | | | |
| 50 | 2 | 40 | 1 5/8 | 195 | 7.68 | 124 | 4.87 | 251 | 9.87 | 308 | 12.15 | 383 | 14.62 | 1 5/8 | 406 | 16.0 | 29 | 1.15 | 133 | 5.25 | 127 | 5 | |
| | | | | | | | | | | | | | | 2 1/8 | 406 | 16.0 | 34 | 1.34 | | | | | |
| | | | | | | | | | | | | | | 2 3/8 | 421 | 16.56 | 37 | 1.47 | | | | | |
| 65 | 2 1/2 | 65 | 2 1/2 | 229 | 9 | 145 | 5.69 | 314 | 12.37 | 381 | 15.0 | 451 | 17.76 | 2 5/8 | 495 | 19.15 | 37 | 1.47 | 170 | 6.69 | 127 | 5 | |
| | | | | | | | | | | | | | | 3 1/8 | 533 | 21.0 | 42 | 1.65 | | | | | |
| 75 | 3 | 75 | 3 | 229 | 9 | 145 | 5.69 | 314 | 12.37 | 381 | 15.0 | 470 | 18.5 | 3 1/8 | 533 | 21.0 | 42 | 1.65 | 170 | 6.69 | 127 | 5 | |
| | | | | | | | | | | | | | | 3 3/8 | 540 | 21.25 | 48 | 1.90 | | | | | |
| 100 | 4 | 100 | 4 | 290.8 | 11.45 | 177.8 | 7.0 | 332.7 | 13.1 | 403.8 | 15.9 | 525.8 | 20.7 | 4 1/8 | 574 | 22.6 | 55 | 2.16 | 172.7 | 6.8 | 165 | 6.5 | |



RSF
13mm (1/2")

Fig. 3

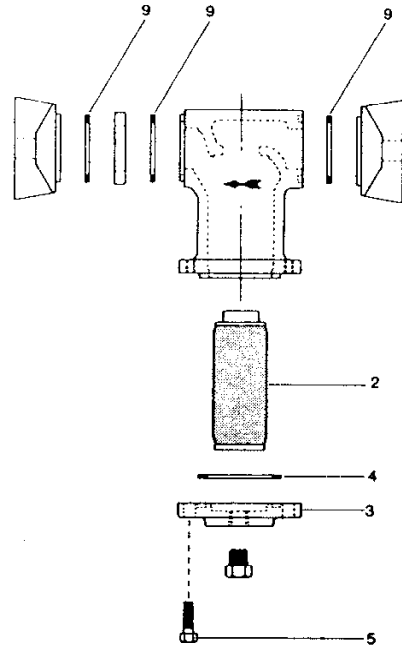

RSF
20-25mm (3/4-1")

Fig. 4

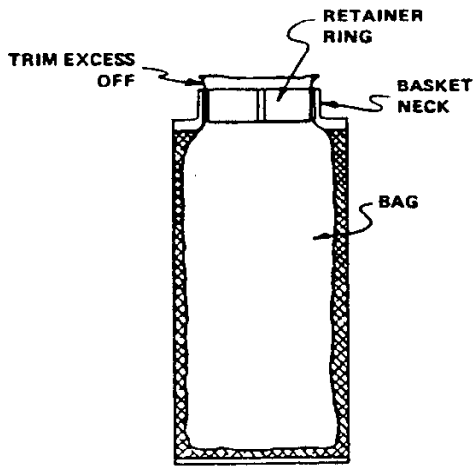

STRAINER BAG KIT
20-100mm (3/4-4")

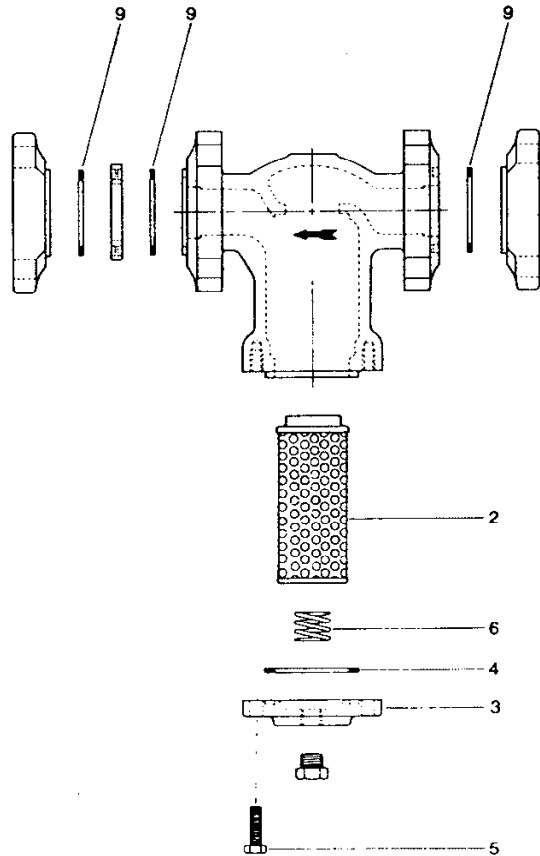

RSF
32-100mm (1 1/4-4")

Fig. 5

- Collapsed Screen Assembly: (a) Possibly caused by reverse flow through the strainer (avoid reverse flow and never open a hand valve downstream of a strainer before a valve upstream has been opened first). (b) Screen Assembly crushed during installation.
- Dirt Passing Through Strainer: (a) Ruptured or collapsed screen assembly. (b) Spring #4 is broken or missing. (c) Fine dirt, less than several thousandths of an inch in size requires more frequent cleaning of the strainer or possible temporary insertion of a R/S Filter Bag where applicable.

Safe Operation

The personnel doing any work on a refrigeration system must be qualified and completely familiar with the system, or all other precautions will be meaningless.

Where cold liquid lines are used, it is important that certain precautions are taken to avoid damage due to liquid expansion. Temperature increase in a section full of solid liquid can cause high pressures due to the expanding liquid and possibly rupture a gasket, pipe or valve. All hand valves in such locations should be marked, warning against accidental closing, and must not be closed until the liquid is removed. Check valves must never be installed upstream of solenoid valves or regulators with electric shut-off, nor should hand valves upstream of solenoid valves or downstream of check valves be closed until the liquid has been removed. It is advisable to install relief devices in any section where liquid expansion could take place. Liquid hammer shocks must be avoided.

For the protection of personnel and products, all refrigerant should be removed from the section to be worked on before a valve, strainer or other device is opened. Special care should be taken when removing refrigerant from a strainer—liquid refrigerant may be entrapped. These R/S Strainers are provided with a 3/8" FPT drain connection in the bottom cap for connecting a drain valve and hose for proper and safe removal of any entrapped liquid refrigerant before opening strainer for inspection.

Strainer inspection is of utmost importance, especially the first few hours, days or weeks after the start-up. The strainers should be opened and any dirt removed. Strainer inspection and cleaning should be continued until dirt accumulation ceases. Later, any time a valve is opened for service or maintenance, its companion strainer should also be inspected and cleaned. See Bulletin RSB for further information.

Installation (see also Bulletin RSB)

When used with R/S Control Valves, the strainer may be bolted directly to the inlet side of the valve to be protected. Standard R/S flange nuts and bolts are used to connect the strainer male outlet flange to the valve female inlet flange. Consequently, only one pair of R/S standard male companion flanges is needed for a close coupled strainer and valve combination. Strainer must be installed in a horizontal line with cover on the bottom.

Allow sufficient space below the Strainer Cover #3 (see page 1), to permit the Screen Assembly #2 to be removed for cleaning. If the strainer is insulated make sure the insulation can be easily removed to allow access to the strainer cover. Installation must be done according to all applicable Safety Codes and Standards, and by personnel qualified to install refrigeration systems. Refrigerating Specialties Division control valves and strainers must be installed

Flange Bolt Torque Requirements

| Bolt Diameter | Valve Port Size | Torque |
|---------------|---------------------|----------------------|
| 11mm (7/16") | 13mm (1/2") | 3.9 mkg (28 ft lb) |
| 16mm (5/8") | 20-50mm (3/4"-2") | 11.8 mkg (85 ft lb) |
| 19mm (3/4") | 65-75mm (2-1/2"-3") | 14.5 mkg (105 ft lb) |
| 22mm (7/8") | 100mm (4") | 22.1 mkg (150 ft lb) |

according to the specific valve's instructions, this bulletin, and generally known safe practices.

Allow proper space for installing the strainer. do not use the strainer to "stretch" or "align" the pipe. Using flange bolts to close a large gap can distort the strainer or at least stress it unduly, or the bolts may be damaged or stripped. For proper sealing the gaskets should be lightly oiled and all bolts must be tightened evenly. Make sure flange tongue and groove are properly aligned. Where necessary support the strainer by brackets or hangers to avoid pipe or valve overstressing.

Since most maintenance problems caused by dirt occur at the start-up of a system, it is advisable to delay insulating the control valves and strainers until the system has operated for several days. During that time the strainers should be checked for dirt and cleaned as necessary. During installation of strainer remove 3/8" pipe plug #5 (see page 1) from cover and install a refrigerant drain valve.

Filter Bag Assembly Instructions

Assembling the 3/4" and 1" filters, support the strainer basket in your hand. The other sizes may be bench rested.

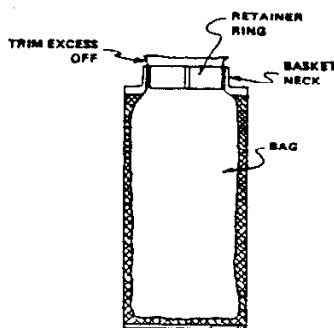

Fig. 6

- Insert bag into filter-basket, allowing a portion of the bag to extend out of the basket neck.
- Place the retainer ring inside the open end of the bag.
- Holding the retainer ring inside the top, open end of the bag, squeeze and insert bag and ring into the neck of the filter.
- Retainer ring must fit flush with top of basket neck.
- Trim protruding bag material and discard.
- Using a pencil, smooth out the bag inside the wire basket.

Bag should now be retained between retainer ring and basket neck inside diameter.

Warranty

All Refrigerating Specialties products are warranted against defects in workmanship and materials for a period of one year from date of shipment from originating factory. This warranty is in force only when products are properly installed, field assembled, maintained and operated in use and service as specifically stated in Refrigerating Specialties Catalogs or Bulletins for normal refrigeration applications, unless otherwise approved in writing by Refrigerating Specialties Division. Defective products, or parts thereof returned to the factory with transportation charges prepaid and found to be defective by factory inspection will be replaced or repaired at Refrigerating Specialties option, free of charge, F.O.B. factory. Warranty does not cover products which have been altered, or repaired in the field; damaged in transit, accidents, misuse, or abuse. Products disabled by dirt or other foreign substances will not be considered defective.

The express warranty above constitutes the only warranty of Refrigerating Specialties products, and is in lieu of all other warranties, expressed or implied, written or oral, INCLUDING ANY WARRANTY OF MERCHANTABILITY OR WARRANTY OF FITNESS FOR A PARTICULAR PURPOSE AND IN NO EVENT IS REFRIGERATING SPECIALTIES RESPONSIBLE FOR ANY CONSEQUENTIAL DAMAGES OF ANY NATURE WHATSOEVER. No employee, agent, dealer or other person is authorized to give any warranties on behalf of Refrigerating Specialties nor to assume for Refrigerating Specialties any other liability in connection with any of its products.

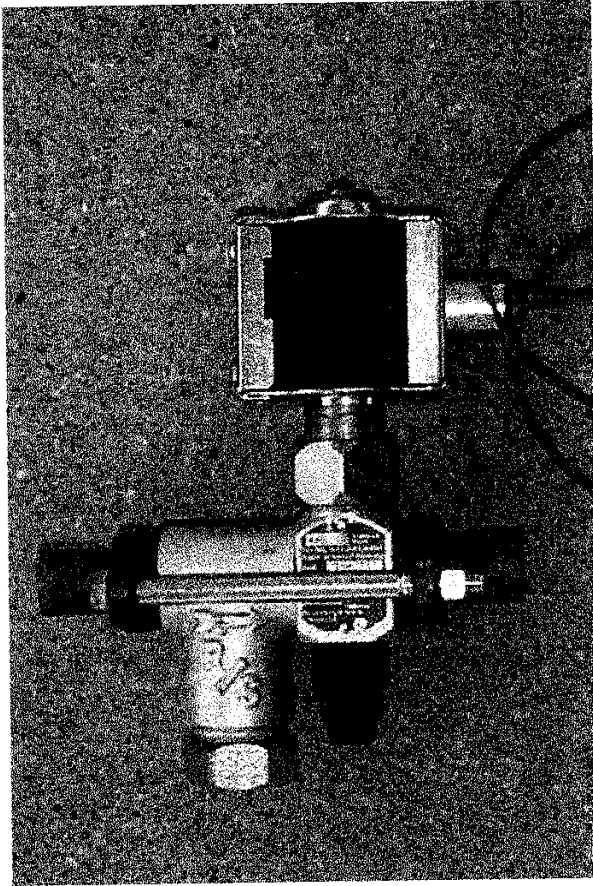

**ASSEMBLED VIEW OF
1/2" PORT, 7/8" ODS
LIQUID LINE SOLENOID
VALVE WITH STRAINER**

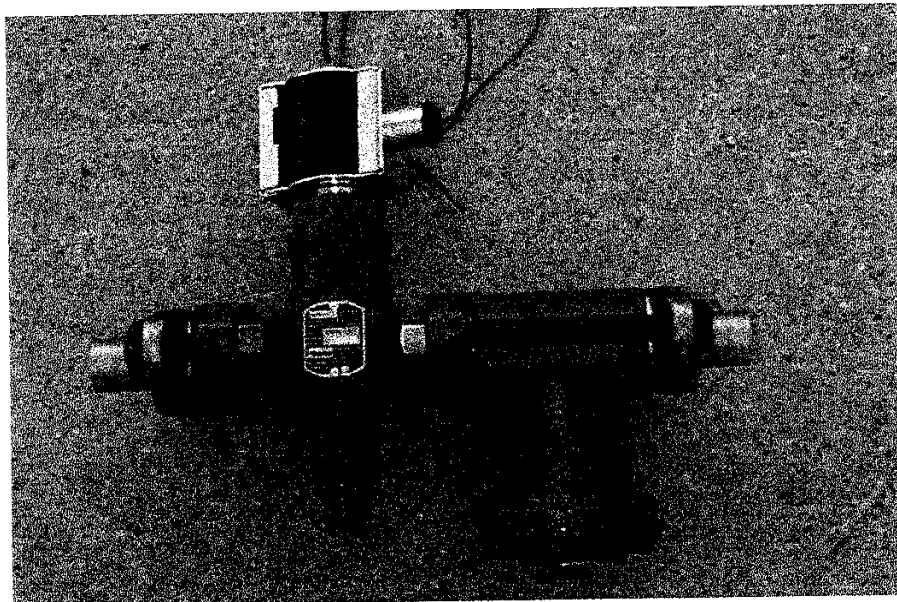

**ASSEMBLED VIEW OF
3/4" PORT, 1 1/8" & 1 3/8" ODS
LIQUID LINE SOLENOID
VALVE WITH STRAINER**

Installation, Operation and Maintenance Instructions

Model 3657/3757

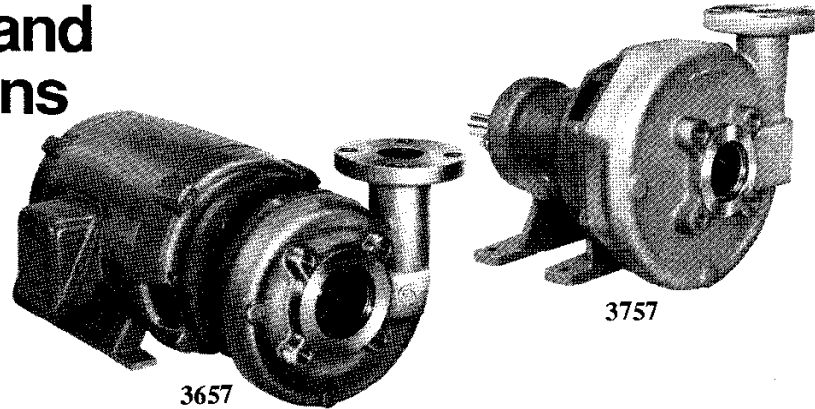

DESCRIPTION & SPECIFICATIONS:

The Models 3657 (close-coupled) and 3757 (frame-mounted) are single-stage end-suction pumps designed for ultra-pure water systems, O.E.M. applications, food and beverage processing and chemical services not demanding ANSI standard equipment.

The pumps have fully enclosed, investment cast, AISI TYPE 316 stainless steel impellers, key driven and held in position by an O-ring sealed locknut. The full volute casings are also investment castings of AISI TYPE 316 stainless steel, back pull-out configuration, with connections for mating with standard 150 Lb. ANSI flanges. Shafts are protected with O-ring sealed stainless steel sleeves. Shaft sealing is with mechanical seal.

Close-coupled units have NEMA frame motors, C-face mounting, JM shaft extension. Frame mounted units can be coupled to motors through a spacer coupling, or belt driven.

1. Important:

1.1. Inspect unit for damage. Report any damage to carrier/dealer immediately.

1.2. Electrical supply must be a separate branch circuit with fuses or circuit breakers, wire sizes, etc., per National and Local electrical codes. Install an all-leg disconnect switch near pump.

CAUTION

Always disconnect electrical power when handling pump or controls.

1.3. Motors must be wired for proper voltage. Motor wiring diagram is on motor nameplate. Wire size must limit maximum voltage drop to 10% of nameplate voltage at motor terminals, or motor life and pump performance will be lowered.

1.4. Always use horsepower-rated switches, contactors and starters.

1.5. Motor Protection:

1.5.1. Single-phase: Thermal protection for single-phase units is sometimes built in (check nameplate). If no built-in protection is provided, use a contactor with a proper overload. Fusing is permissible.

1.5.2. Three-phase: Provide three-leg protection with properly sized magnetic starter and thermal overloads.

1.6. Maximum Operating Limit(s):

Liquid Temp.: 212F (100C) with standard seal.
250F (120C) with optional high temp seal.

Pressure: 175 PSI.

Starts Per Hour: 20, evenly distributed.

1.7. Regular inspection and maintenance will increase service life. Base schedule on operating time. Refer to Section 8.

2. Installation:

2.1. General

2.1.1. Locate pump as near liquid source as possible (below level of liquid for automatic operation).

2.1.2. Protect from freezing or flooding.

2.1.3. Allow adequate space for servicing and ventilation.

2.1.4. All piping must be supported independently of the pump, and must "line-up" naturally.

CAUTION

Never draw piping into place by forcing the pump suction and discharge connections.

2.1.5. Avoid unnecessary fittings. Select sizes to keep friction losses to a minimum.

2.1.6. After the piping is complete, rotate the unit by hand to check for any binding.

2.2. Close-Coupled Units:

2.2.1. Units may be installed horizontally, inclined or vertically.

CAUTION

Do not install with motor below pump. Any leakage or condensation will affect the motor.

2.2.2. Foundation must be flat and substantial to eliminate strain when tightening bolts. Use rubber mounts to minimize noise and vibration.

2.2.3. Tighten motor hold-down bolts before connecting piping to pump.

2.3. Frame-Mounted Units:

2.3.1. Bedplate must be grouted to a foundation with solid footing. Refer to Fig. 1.

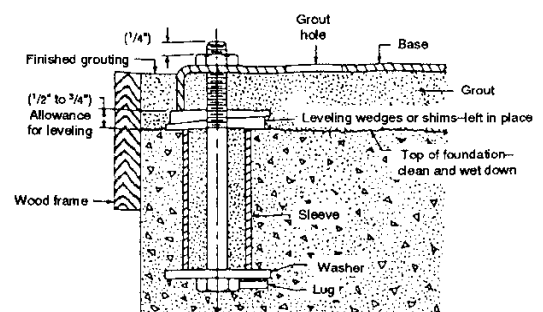

Figure 1

2.3.2. Place unit in position on wedges located at four points (two below approximate center of driver and two below approximate center of pump). Adjust wedges to level unit. Level or plumb suction and discharge flanges.

2.3.3. Make sure bedplate is not distorted and final coupling alignment can be made within the limits of movement of motor and by shimming, if necessary.

2.3.4. Tighten foundation bolts finger tight and build dam around foundation. Pour grout under bedplate making sure the areas under pump and motor feet are filled solid. Allow grout to harden 48 hours before fully tightening foundation bolts.

2.3.5. Tighten pump and motor hold-down bolts before connecting the piping to pump.

3. Suction Piping:

3.1. Low static suction lift and short, direct, suction piping is desired. For suction lift over 10 feet and liquid temperatures over 120 F, consult pump performance curve for Net Positive Suction Head Required.

3.2. Suction pipe must be at least as large as the suction connection of the pump. Smaller size will degrade performance.

3.3. If larger pipe is required, an eccentric pipe reducer (with straight side up) must be installed at the pump.

3.4. Installation with pump below source of supply:

3.4.1. Install full flow isolation valve in piping for inspection and maintenance.

CAUTION

Do not use suction isolation valve to throttle pump.

3.5. Installation with pump above source of supply:

3.5.1. Avoid air pockets. No part of piping should be higher than pump suction connection. Slope piping upward from liquid source.

3.5.2. All joints must be airtight.

3.5.3. Foot valve to be used only if necessary for priming, or to hold prime on intermittent service.

3.5.4. Suction strainer open area must be at least triple the pipe area.

3.6. Size of inlet from liquid source, and minimum submergence over inlet, must be sufficient to prevent air entering pump through vortexing. See Figs. 2-5.

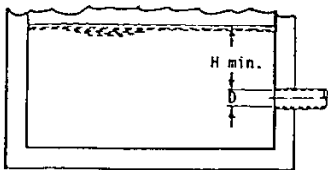

Figure 2

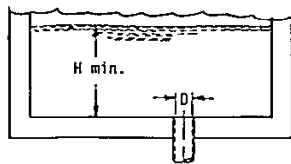

Figure 3

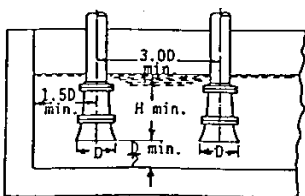

Figure 4

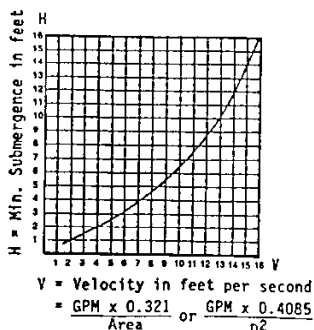

Figure 5

4. Discharge Piping:

4.1. Arrangement must include a check valve located between a gate valve and the pump. The gate valve is for regulation of capacity, or for inspection of the pump or check valve.

4.2. If an increaser is required, place between check valve and pump.

5. Motor-To-Pump Shaft Alignment:

5.1. Close-Coupled Units:

5.1.1. No field alignment necessary.

5.2. Frame-Mounted units:

5.2.1. Even though the pump-motor unit may have a factory alignment, this could be disturbed in transit and must be checked prior to running. See Fig. 6.

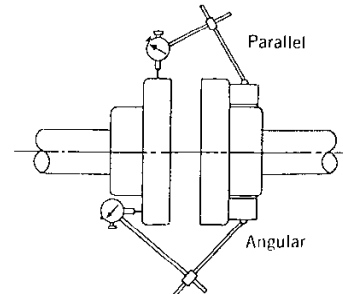

Figure 6

5.2.2. Tighten all hold-down bolts before checking the alignment.

5.2.3. If re-alignment is necessary, always move the motor. Shim as required.

5.2.4. Parallel misalignment - shafts with axis parallel but not concentric. Place dial indicator on one hub and rotate this hub 360 degrees while taking readings on the outside diameter of the other hub. Parallel alignment occurs when Total Indicator Reading is .005", or less.

5.2.5. Angular misalignment - shafts with axis concentric but not parallel. Place dial indicator on one hub and rotate this hub 360 degrees while taking readings on the face of the other hub. Angular alignment is achieved when Total Indicator Reading is .005", or less.

5.2.6. Final alignment is achieved when parallel and angular requirements are satisfied with motor hold-down bolts tight.

CAUTION

Always recheck both alignments after making any adjustment.

6. Rotation:

6.1. Correct rotation is right-hand (clockwise when viewed from the motor end). Switch power on and off quickly. Observe shaft rotation. To change rotation:

6.1.1. Single-phase: Refer to wiring diagram on motor.

6.1.2. Three-phase: Interchange any two power supply leads.

7. Operation:

7.1. Before starting, pump must be primed (free of air and suction pipe full of liquid) and discharge valve partially open.

CAUTION

Pumped liquid provides lubrication. If pump is run dry, rotating parts will seize and mechanical seal will be damaged. Do not operate at or near zero flow. Energy imparted to the liquid is converted into heat. Liquid may flash to vapor. Rotating parts require liquid to prevent scoring or seizing.

7.2. Make complete check after unit is run under operating conditions and temperature has stabilized. Check for expansion of piping. On frame-mounted units coupling alignment may have changed due to the temperature differential between pump and motor. Recheck alignment.

8. Maintenance:

8.1. Close-Coupled Units: Bearings are located in and are part of the motor. For lubrication procedure, refer to motor manufacturer's instructions.

8.2. Frame-Mounted Units:

8.2.1. Bearing frame should be regreased every 2,000 hours or 3 month interval, whichever occurs first. Use a #2 sodium or lithium based grease. Fill until grease comes out of relief fittings, or lip seals, then wipe off excess.

8.2.2. Follow motor and coupling manufacturers' lubrication instructions.

8.2.3. Alignment must be rechecked after any maintenance work involving any disturbance of the unit.

9. Disassembly:

Complete disassembly of the unit will be described. Proceed only as far as required to perform the maintenance work needed.

9.1. Turn off power.

9.2. Drain system. Flush if necessary.

9.3. Close-Coupled Units: Remove motor hold-down bolts.

Frame-Mounted Units: Remove coupling, spacer, coupling guard and frame hold-down bolts.

9.4. Disassembly of Liquid End:

9.4.1. Remove casing bolts (370).

9.4.2. Remove back pull-out assembly from casing (100).

9.4.3. Unscrew impeller nut (304) with a socket wrench.

CAUTION

Do not insert screwdriver between impeller vanes to prevent rotation.

It may be necessary to use a strap wrench around the impeller if impacting the socket wrench will not loosen the impeller bolt. Hold shaft on frame mounted units.

9.4.4. Use two pry bars, 180 degrees apart, to remove impeller (101) from shaft.

9.4.5. Remove impeller key (178) and seal spring.

9.4.6. With two pry bars 180 degrees apart inserted through the windows of the motor adapter (108), pry on the end of the shaft sleeve (125). The mechanical seal rotary unit (383) will come off with the sleeve.

9.4.7. Remove the seal housing to adapter bolts (370H). Remove seal housing (184) together with stationary seal parts.

9.4.8. Place seal housing on flat surface and press out stationary seal parts.

9.5. Disassembly of bearing frame:

9.5.1. Remove bolts (370C) and bearing cover (134). Slide V-ring deflector (123) off shaft.

9.5.2. Remove shaft assembly from frame (228).

9.5.3. Remove lip seals (333A) from bearing frame and bearing cover if worn and are being replaced.

9.5.4. Straighten tang in lockwasher (382). Remove locknut (136) and lockwasher.

9.5.5. Use bearing puller or arbor press to remove ball bearings (112 & 168).

10. Reassembly:

10.1. All parts should be cleaned before assembly.

10.2. Refer to parts list to identify required replacement items. Specify pump index or catalog number when ordering parts.

10.3. Reassembly is the reverse of disassembly.

10.4. Observe the following when reassembling the bearing frame:

10.4.1. Replace lip seals if worn or damaged.

10.4.2. Replace ball bearings if loose, rough or noisy when rotated.

10.4.3. Check shaft for runout at the sleeve area. Maximum permissible is .002" T.I.R.

10.5. Observe the following when reassembling the liquid-end:

10.5.1. All mechanical seal components must be in good condition or leakage may result. Replacement of complete seal assembly, whenever seal has been removed, is good standard practice.

It is permissible to use a light lubricant, such as glycerin, to facilitate assembly. Do not contaminate the mechanical seal faces with lubricant.

10.5.2. Inspect seal housing O-ring (513) and replace if damaged. This O-ring may be lubricated with petroleum jelly to ease assembly.

10.5.3. Inspect impeller O-rings (412A) at the sleeve and locknut. Replace if damaged.

10.6. Check reassembled unit for binding. Correct as required.

11. Trouble Shooting Guide:

MOTOR NOT RUNNING:

(See causes 1 thru 6)

LITTLE OR NO LIQUID DELIVERED:

(See causes 7 thru 17)

POWER CONSUMPTION TOO HIGH:

(See causes 4, 17, 18, 19, 22)

EXCESSIVE NOISE AND VIBRATION:

(See causes 4, 6, 9, 13, 15, 16, 18, 20, 21, 22)

PROBABLE CAUSE:

1. Tripped thermal protector
2. Open circuit breaker
3. Blown fuse
4. Rotating parts binding
5. Motor wired improperly
6. Defective motor
7. Not primed
8. Discharge plugged or valve closed
9. Incorrect rotation
10. Foot valve too small, suction not submerged, inlet screen plugged
11. Low voltage
12. Phase loss (3-phase only)
13. Air or gasses in liquid
14. System head too high
15. NPSHA too low:
Suction lift too high or suction losses excessive.
Check with vacuum gauge.
16. Impeller worn or plugged
17. Incorrect impeller diameter
18. Head too low causing excessive flow rate
19. Viscosity or specific gravity too high
20. Worn bearings
21. Pump or piping loose
22. Pump and motor misaligned

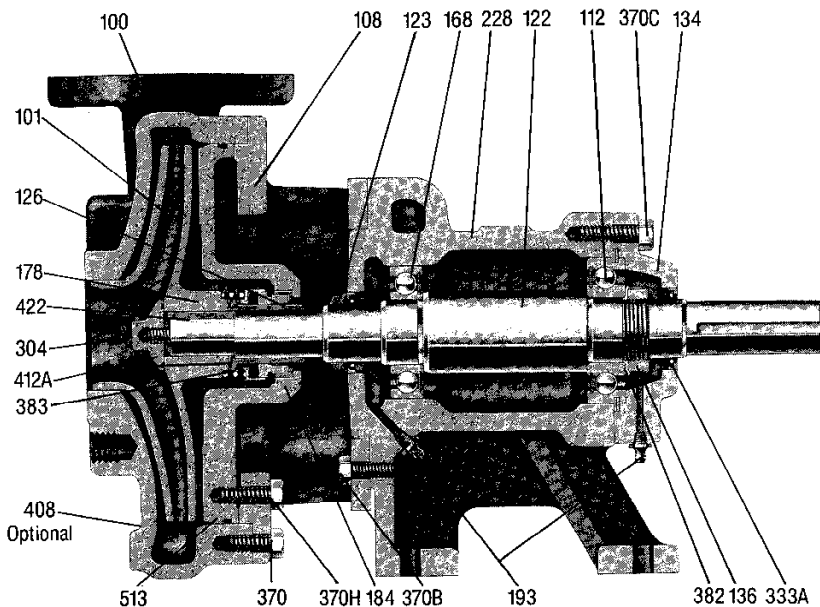

Model 3757

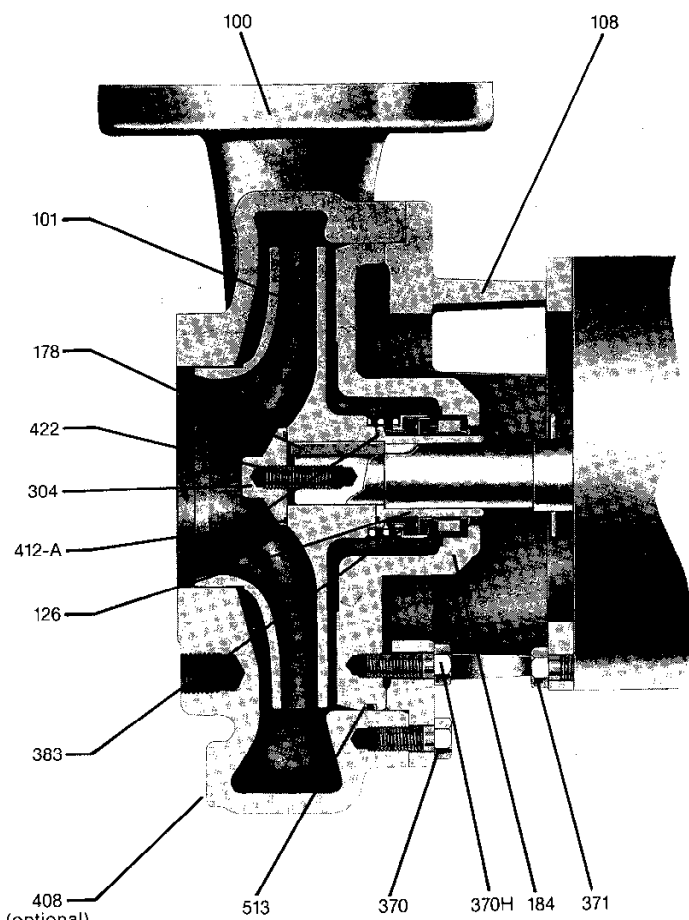

Model 3657

Materials of Construction

| Pump End Components | | | | | | | |
|--------------------------|---|--------------------------|---------------------------|------------------|------------|------------|-------------|
| Item No. | Description | Material | | | | | |
| 100* | Casing | 316 S.S. Investment Cast | | | | | |
| 101* | Impeller | | | | | | |
| 184* | Seal Housing | | | | | | |
| 304* | Impeller Nut | 316 S.S. | | | | | |
| 422 | Impeller Stud | Steel | | | | | |
| 178 | Impeller Key | | | | | | |
| 126* | Shaft Sleeve | 316 S.S. | | | | | |
| 412A | O-Ring Impeller | BUNA | | | | | |
| 408* | Pipe Plug-1/4" NPT (casing drain) | 316 S.S. | | | | | |
| 513 | O-Ring Casing | BUNA | | | | | |
| 370 | Hex Head Cap Screw (Adapter to Casing) | 304 S.S. | | | | | |
| 370H | Hex Head Cap Screw (Adapter to Seal Housing) | | | | | | |
| John Crane Type 21 | | | | | | | |
| 383 | Mechanical Seal | Goulds Parts No. | Service | Rotary | Stationary | Elastomers | Metal Parts |
| | Standard | 10K13 | General | | Ceramic | BUNA | 316 S.S. |
| | Optional | 10K19 | Hi-Temp | | Ni-Resist | EPR | |
| | Optional | 10K25 | Chem-Duty | Carbon | Ceramic | VITON | |
| Optional | 10K27 | Hi-Temp | | Tungsten Carbide | EPR | | |
| Power End Components | | | | | | | |
| 108 | Adapter | Cast Iron | | | | | |
| 228 | Bearing Frame | | | | | | |
| 122 | Pump Shaft | Steel | | | | | |
| 168 | Ball Bearing (Inboard) | | | | | | |
| 112 | Ball Bearing (Outboard) | BUNA-N | | | | | |
| 123 | V-Ring Deflector | | | | | | |
| 136 | Lock Nut Bearing | Steel | | | | | |
| 382 | Lock Washer Bearing | | | | | | |
| 134 | Bearing Cover | Cast Iron | | | | | |
| 333A | Lip Seal Bearing | BUNA/Steel | | | | | |
| 193 | Grease Fitting | Steel | | | | | |
| 370B | Hex Head Cap Screw (Adapter to Bearing Frame) | | | | | | |
| 370C | Hex Head Cap Screw (Bearing Frame to Cover) | | | | | | |
| Materials Specifications | Material | | Engineering Standard | | | | |
| | Cast Iron | | ASTM A48 CL20 | | | | |
| | Steel | | ASTM A108/SAE 1200 Series | | | | |
| | 316 S.S. Investment Cast | | ASTM A743 Grade CF-8M | | | | |
| | 316 S.S. | | ASTM A276 Type 316 | | | | |
| 304 S.S. | | ASTM A276 Type 304 | | | | | |

*Indicates components exposed to pumpage.

LIMITED WARRANTY

This warranty applies to all pumps and related accessories manufactured and/or supplied by Goulds Pumps, Inc. - Water Systems Division.

Any part or parts found to be defective within the warranty period shall be replaced at no charge to the buyer or any subsequent owner during the warranty period. The warranty period shall exist for twelve (12) months from date of installation, or eighteen (18) months from date of manufacture, whichever expires first.

A consumer who believes that a warranty claim exists must contact the authorized dealer from whom the equipment was originally purchased and furnish complete details regarding the claim. The dealer is authorized to adjust any warranty claim utilizing Goulds Customer Relations Department and its distributor organization.

This warranty excludes: (a) Labor, transportation and related costs incurred by the consumer to make the allegedly defective equipment available to the dealer for inspection. (b) Re-installation costs of repaired equipment. (c) Re-installation costs of replacement equipment. (d) Consequential damages of any kind. (e) Reimbursement for loss caused by interruption of service.

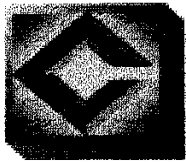

**CONSTRUCTION
EQUIPMENT**

DWG. No. 118-67, IMP. DIAS. for 1.0 S.F.
© 1968, 1969, 1970, 1971, 1972, 1973, 1974, 1975, 1976, 1977, 1978, 1979, 1980, 1981, 1982, 1983, 1984, 1985, 1986, 1987, 1988, 1989, 1990, 1991, 1992, 1993, 1994, 1995, 1996, 1997, 1998, 1999, 2000, 2001, 2002, 2003, 2004, 2005, 2006, 2007, 2008, 2009, 2010, 2011, 2012, 2013, 2014, 2015, 2016, 2017, 2018, 2019, 2020, 2021, 2022, 2023, 2024, 2025

Pump Size 1-1/2 x 2 - 6

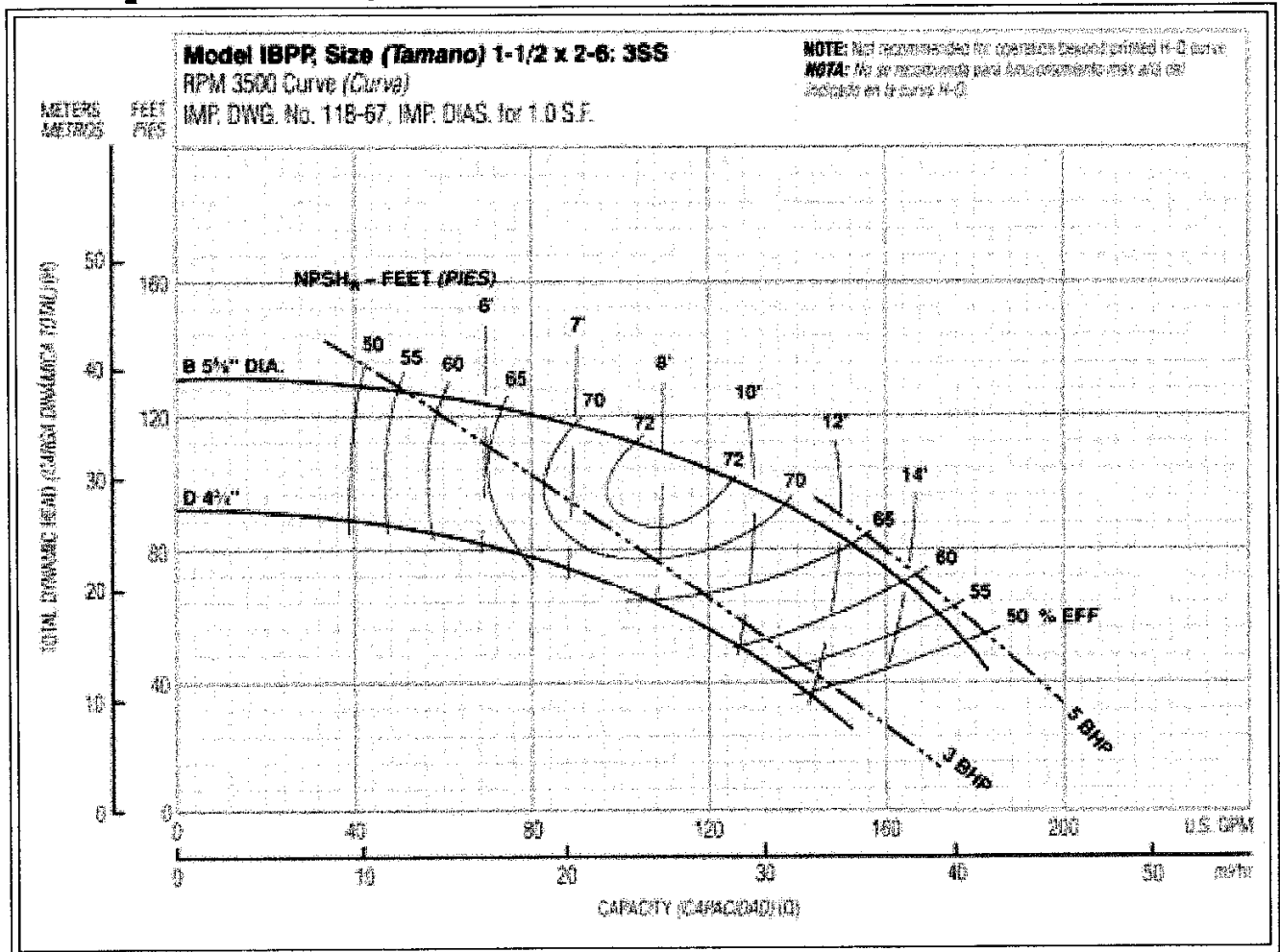

Model IBPP-3-3500 (4-3/4" Dia.) 100 GPM @ 70 Ft - 3HP

Model IBPP-5-3500 (5-5/8" Dia.) 130 GPM @ 95 Ft - 5HP



Pump Construction

Ø ± 1/16" x PDD

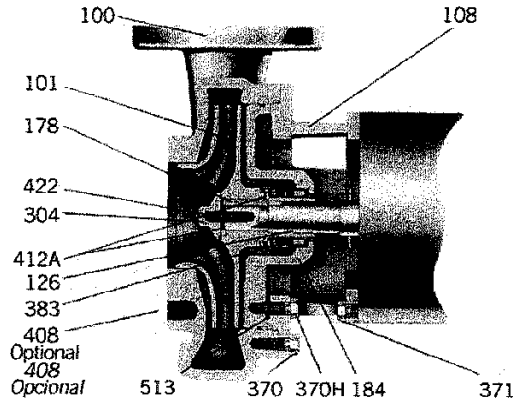

| Item No., Pieza No. | Description, Descripción | Materials, Materiales |
|------------------------|---|--|
| 100 | Casing, Carcasa | 316 SS investment cast, Fundición acero inoxidable 316 |
| 101 | Impeller, Impulsor | |
| 108 | Motor adapter, Adaptador del motor | Cast iron, Hierro fundido |
| 126 | Shaft sleeve, Camisa del eje | 316 SS, Acero inoxidable 316 |
| 178 | Impeller key, Del impulsor | Steel, Acero |
| 184 | Seal housing, Caja del sello | 316SS investment cast, Fundición acero inoxidable 316 |
| 304 | Impeller nut, Tuerca del impulsor | 316 SS, Acero inoxidable 316 |
| 370 | Hex head cap screw (adapter to casing), Tornillo de cabeza hexagonal, (adaptador para carcasa) | 304 SS, Acero inoxidable 304 |
| 370H | Hex head cap screw (adapter to seal housing), Tornillo de cabeza hexagonal, (adaptador para caja del sello) | 304 SS, Acero inoxidable 304 |
| 371 | Hex head cap screw (motor adapter to motor), Tornillo de cabeza hexagonal, (adaptador del motor para motor) | 304 SS, Acero inoxidable 304 |

| Item No., Pieza No. | Description, Descripción | Materials, Materiales |
|------------------------|---|---------------------------------|
| 408 | Pipe plug - 1/4" NPT (optional) Tapón de tubería - 1/4" NPT (Opcional) | 316 SS, Acero inoxidable 316 |
| 412A | O-ring, Impeller; Anillo en O, Impulsor | Viton, Vitón |
| 422 | Impeller stud, Vástago del impulsor | Steel, Acero |
| 513 | O-ring, casing; Anillo en O, carcasa | Viton, Vitón |

| Materials of Construction, Materiales de Construcción | Material, Materiales | Engineering Standard, Normal Industrial |
|--|---|---|
| | Cast iron, Hierro fundido | Cast iron ASTM A48 CL20, Hierro fundido ASTM A 48 CL20 |
| 316 SS investment cast, Fundición acero inoxidable 316 | ASTM A743 grade CF-8M, ASTM A743 grado CF-8M | |
| 316 SS, Acero inoxidable 316 | ASTM A276 type 316, ASTM A276 tipo 316 | |
| 304 SS, Acero inoxidable 304 | ASTM A276 type 304, ASTM A276 tipo 304 | |
| Steel, Acero | ASTM A108 SAE 1200 series | |

John Crane Type 21, John Crane Tipo 21

| Mechanical Seal, Sello Mecánico | Goude Part No. Pieza No. de Goude | Service, Servicio | Rotary, Rotatorio | Stationary, Estacionario | Elastomers, Elastómeros | Metal Parts, Partes Metálicas |
|--|--|------------------------|----------------------|---|----------------------------|--|
| Optional, Opcional | 10K19 | Hi-Temp, Alta Temp. | | Ni-Resist, Resist-Ni | EPR, EPR | 316 SS, Acero inoxidable 316 |
| Standard, Estándar | 10K25 | Chem-Duty, Químico | Carbon, Carbon | Ceramic, Cerámica | Viton, Vitón | |
| Optional, Opcional | 10K27 | Hi-Temp, Alta Temp. | | Tung. Carbide, Carburo de tungsteno | Viton, Vitón | |

INSTALLATION AND MAINTENANCE INSTRUCTIONS

2-WAY INTERNAL PILOT OPERATED SOLENOID VALVES HUNG DIAPHRAGM — 3/8, 1/2 AND 3/4 N.P.T. NORMALLY CLOSED OPERATION

BULLETINS

8210

8211



Form No. V-5825

DESCRIPTION

Bulletin 8210's are 2-way, normally closed, internal pilot operated solenoid valves. Valve body and bonnet are of brass construction. Standard valves have a General Purpose, NEMA Type 1 Solenoid Enclosure.

Bulletin 8211's are the same as Bulletin 8210's except the solenoids are equipped with an enclosure which is designed to meet NEMA Type 4 Watertight, NEMA Type 7 (C or D) Hazardous Locations - Class I, Group C or D, and NEMA Type 9 (E, F or G) Hazardous Locations - Class II, Group E, F or G. The explosion-proof/watertight solenoid enclosure is shown on a separate sheet of Installation and Maintenance Instructions, Form No. V-5380.

Bulletin 8210 and 8211 valves with suffix 'HW' in the catalog number are specifically designed for hot water service.

OPERATION

Normally Closed: Valve is closed when solenoid is de-energized and opens when solenoid is energized.

MANUAL OPERATOR (Optional)

Valves with suffix 'MO' in catalog number are provided with a manual operator which allows manual operation when desired or during an interruption of electrical power. To operate valve manually, push in knurled cap and rotate clockwise 180°. Disengage manual operator by rotating knurled cap counterclockwise 180° before operating electrically.

MANUAL OPERATOR LOCATION (Refer to Figure 3)

Manual operator (when shipped from factory) will be located over the valve outlet. Manual operator may be relocated at 90° increments by rotating valve bonnet. Remove bonnet screws (4) and rotate valve bonnet with solenoid to desired position. Replace bonnet screws (4) and torque in a crisscross manner to 110 ± 10 inch pounds.

If valve is installed in system and is operational, proceed in the following manner:

WARNING: Depressurize valve and turn off electrical power supply.

1. Remove retaining cap or clip and slip the entire solenoid enclosure off the solenoid base sub-assembly. CAUTION: When metal retaining clip disengages, it will spring upwards.
2. Remove bonnet screws (4) and rotate valve bonnet to desired position.
3. Replace bonnet screws (4) and torque in a crisscross manner to 110 ± 10 inch pounds.
4. Replace solenoid enclosure and retaining clip or cap.

INSTALLATION

Check nameplate for correct catalog number, pressure, voltage and service.

TEMPERATURE LIMITATIONS

For maximum valve ambient and fluid temperatures refer to chart. The temperature limitations listed are for UL applications. For non UL applications, higher ambient and fluid temperature limitations are available. Consult factory. Check catalog number on nameplate to determine maximum temperatures.

| Construction | Coil Class | Catalog Number Prefix | Maximum Ambient Temp. °F. | Maximum Fluid Temp. °F. |
|---|------------|-----------------------|---------------------------|-------------------------|
| A-C Construction (Alternating Current) | A | None or DA | 77 | 180 |
| | F | DF or FT | 122 | 180 |
| | H | HT | 140 | 180 |
| D-C Construction (Direct Current) | A, F or H | None, FT or HT | 77 | 150 |
| Catalog Numbers Suffixed 'HW' A-C Construction (Alternating Current) | A | None or DA | 77 | 210 |
| | F | DF or FT | 77 | 210 |
| | H | HT | 122 | 210 |

POSITIONING/MOUNTING

Valve may be mounted in any position. For mounting bracket (optional feature) dimensions, refer to Figure 1.

PIPING

Connect piping to valve according to markings on valve body. Apply pipe compound sparingly to male pipe threads only; if applied to valve threads, it may enter the valve and cause operational difficulty. Pipe strain should be avoided by proper support and alignment of piping. When tightening the pipe do not use valve as a lever. Wrenches applied to valve body or piping are to be located as close as possible to connection point. **IMPORTANT: Valves with suffix 'HW' in the catalog number have a special diaphragm material which is specifically compounded for hot water service. This material can be attacked by oil and grease. Wipe the pipe threads clean of cutting oils and use teflon tape to seal pipe joints.**

IMPORTANT: For the protection of the solenoid valve, install a strainer or filter suitable for the service involved in the inlet side as close to the valve as possible. Periodic cleaning is required depending on the service conditions. See Bulletins 8600, 8601 and 8602 for strainers.

WIRING

Wiring must comply with Local and National Electrical Codes. Housings for all solenoids are provided with connections for 1/2 inch conduit. The general purpose solenoid enclosure may be rotated to facilitate wiring by removing the retaining cap or clip. CAUTION: When metal retaining clip disengages it will spring upwards. Rotate to desired position. Replace retaining cap or clip before operating.

NOTE: Alternating Current (A-C) and Direct Current (D-C) Solenoids are built differently. To convert from one to the other, it is necessary to change the complete solenoid including the solenoid base sub-assembly and core assembly.

SOLENOID TEMPERATURE

Standard catalog valves are supplied with coils designed for continuous duty service. When the solenoid is energized for a long period, the solenoid enclosure becomes hot and can be touched with the hand for only an instant. This is a safe operating temperature. Any excessive heating will be indicated by the smoke and odor of burning coil insulation.

MAINTENANCE

WARNING: Turn off electrical power and depressurize valve before making repairs. It is not necessary to remove valve from pipe line for repairs.



CLEANING

A periodic cleaning of all solenoid valves is desirable. The time between cleanings will vary, depending on media and service conditions. In general, if the voltage to the coil is correct, sluggish valve operation, excessive leakage or noise will indicate that cleaning is required.

PREVENTIVE MAINTENANCE

1. Keep the medium flowing through the valve as free from dirt and foreign material as possible.
2. While in service, operate valve at least once a month to insure proper opening and closing.
3. Periodic inspection (depending on media and service conditions) of internal valve parts for damage or excessive wear is recommended. Thoroughly clean all parts. Replace any parts that are worn or damaged.

IMPROPER OPERATION

1. **Faulty Control Circuit:** Check electrical system by energizing solenoid. A metallic click signifies the solenoid is operating. Absence of the click indicates loss of power supply. Check for loose or blown-out fuses, open circuited or grounded coil, broken lead wires or splice connections.
2. **Burned-Out Coil:** Check for open circuited coil. Replace coil if necessary.
3. **Low Voltage:** Check voltage across coil leads. Voltage must be at least 85% of nameplate rating.
4. **Incorrect Pressure:** Check valve pressure. Pressure to the valve must be within range specified on nameplate.
5. **Excessive Leakage:** Disassemble valve and clean all parts. Replace worn or damaged parts with a complete Spare Parts Kit for best results.

COIL REPLACEMENT (Refer to Figure 2)

Turn off electrical power supply and disconnect coil leads. Proceed in the following manner:

1. Remove retaining cap or clip, nameplate and cover. CAUTION: When metal retaining clip disengages, it will spring upwards.
2. Remove spring washer, insulating washer and coil. Insulating washers are omitted when a molded coil is used.
3. Reassemble in reverse order of disassembly paying careful attention to exploded view provided for identification and placement of parts.

CAUTION: Solenoid must be fully reassembled as the housing and internal parts are part of and complete the magnetic circuit. Place insulating washer at each end of coil if required.

VALVE DISASSEMBLY (Refer to Figures 2 and 3)

Depressurize valve and turn off electrical power supply. Proceed in the following manner:

1. Remove retaining cap or clip and slip the entire solenoid enclosure off the solenoid base sub-assembly. CAUTION: When metal retaining clip disengages, it will spring upwards.
2. Unscrew solenoid base sub-assembly and remove bonnet gasket.
3. Remove valve bonnet screws (4) and valve bonnet.
4. For normal maintenance, it is not necessary to disassemble the manual operator (optional feature) unless external leakage is evident. To disassemble remove stem pin, manual operator stem, stem spring and stem gasket.
5. Remove core spring, core/diaphragm sub-assembly and body gasket. CAUTION: Do not damage or distort hanger spring between core/diaphragm sub-assembly.
6. All parts are now accessible for cleaning or replacement. Replace worn or damaged parts with a complete Spare Parts Kit for best results.

VALVE REASSEMBLY

1. Reassemble in reverse order of disassembly paying careful attention to exploded views provided for identification and placement of parts.
2. Replace body gasket and core/diaphragm sub-assembly. Locate the bleed hole in core/diaphragm sub-assembly approximately 45° from the valve outlet.
3. Replace core spring with wide end in core first; closed end protrudes from top of core.
4. If removed, replace manual operator stem, stem spring, stem gasket and stem pin.
5. Replace valve bonnet and bonnet screws (4). Torque bonnet screws (4) in a crisscross manner to 110 ± 10 inch pounds.
6. Replace bonnet gasket and solenoid base sub-assembly. Put solenoid base sub-assembly to 175 ± 25 inch pounds.
7. Replace solenoid enclosure and retaining cap or clip.
8. After maintenance, operate the valve a few times to be sure of proper opening and closing.

SPARE PARTS KITS

Spare Parts Kits and Coils are available for ASCO valves. Parts marked with an asterisk (*) are supplied in Spare Parts Kits.

ORDERING INFORMATION FOR SPARE PARTS KITS

When Ordering Spare Parts Kits or Coils
Specify Valve Catalog Number,
Serial Number and Voltage.

PARTIAL VIEW OF MOUNTING BRACKET (OPTIONAL)

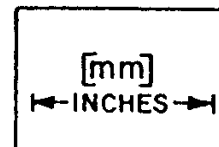
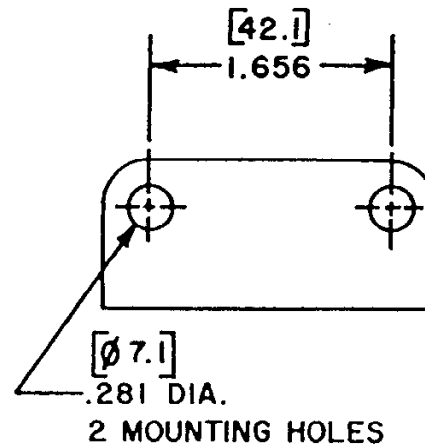

Dimensions For Mounting Bracket
(Optional Feature)

Figure 1.



ASCO Valves
Automatic Switch Co.

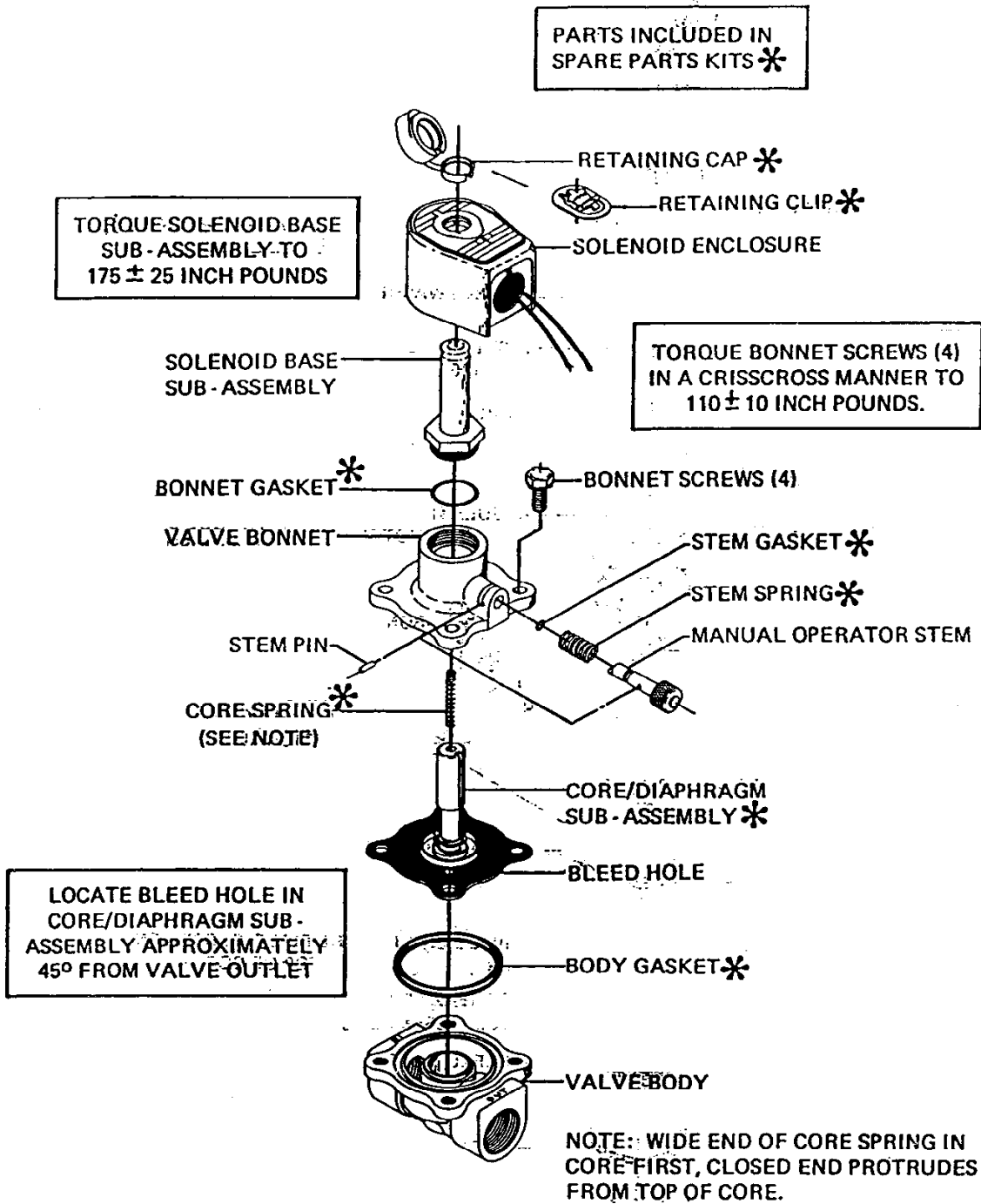
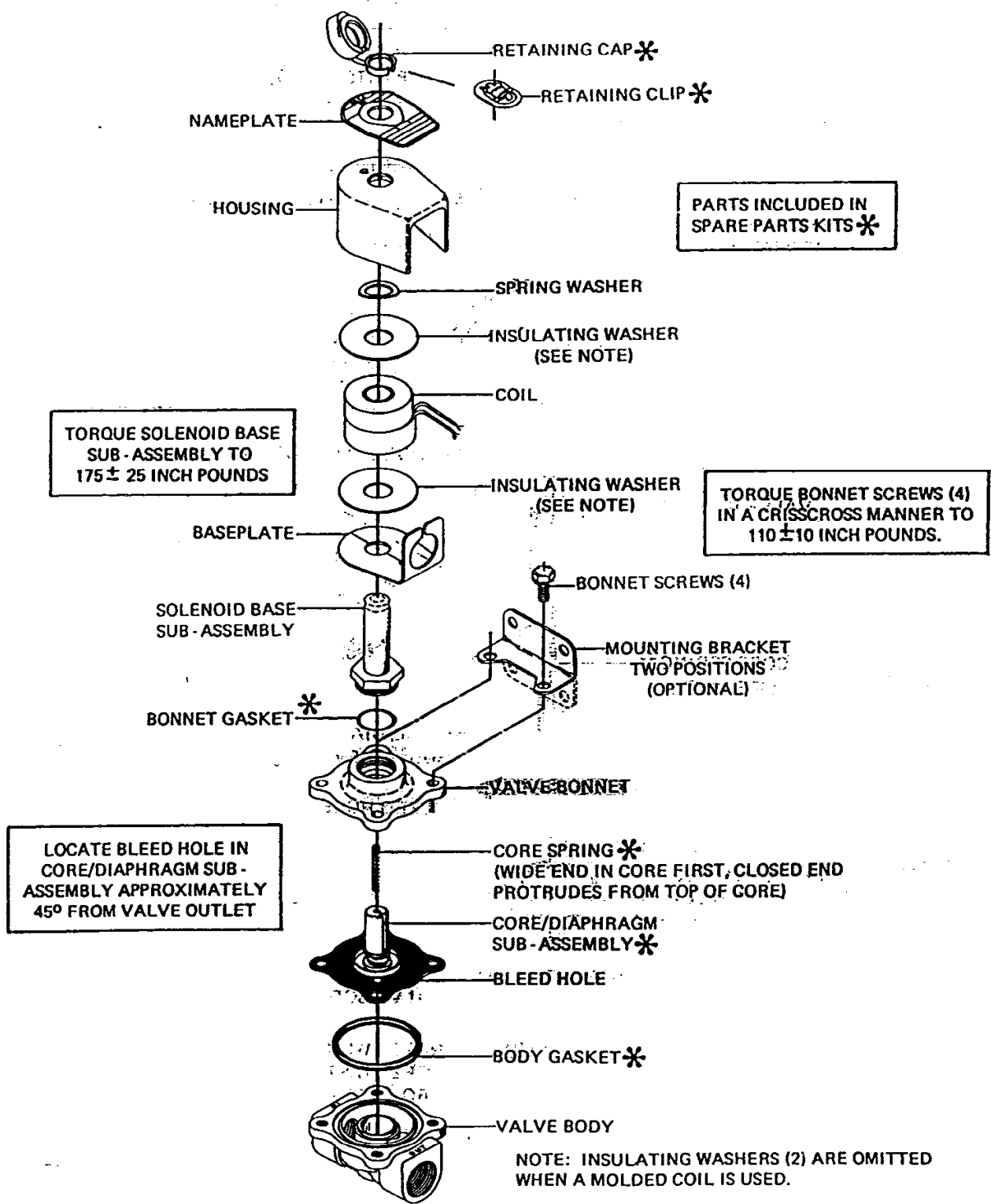

Figure 3. Bulletin 8210 — Manual Operator General purpose solenoid enclosure shown. For explosion-proof/watertight solenoid enclosure used on Bulletin 8211, see Form No. V-5380.



Bulletin 8210 — 3/8, 1/2 & 3/4 N.P.T. — A-C Construction
 General purpose solenoid enclosure shown.

Figure 2.

For explosion-proof/watertight solenoid enclosure used on Bulletin 8211, see Form No. V-5380.

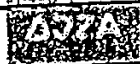

Installation & Maintenance Instructions



OPEN-FRAME, GENERAL PURPOSE, WATERTIGHT/EXPLOSIONPROOF SOLENOIDS

SERIES

8003G

8202G

Form No. V6584R5

— SERVICE NOTICE —

ASCO[®] solenoid valves with design change letter "G" or "H" in the catalog number (ex 8210G 1) have an epoxy encapsulated ASCO[®] Red Hat II[®] solenoid. This solenoid replaces some of the solenoids with metal enclosures and open-frame constructions. Follow these installation and maintenance instructions if your valve or operator uses this solenoid.

See separate instructions for basic valve.

DESCRIPTION

Catalog numbers 8003G and 8202G are epoxy encapsulated pull-type solenoids. The green solenoid with lead wires and 1/2" conduit connection is designed to meet Enclosure Type 1—General Purpose, Type 2—Dripproof, Types 3 and 3S—Raintight, and Types 4 and 4X—Watertight. The black solenoid on catalog numbers prefixed "EF" is designed to meet Enclosure Types 3 and 3S—Raintight, Types 4 and 4X—Watertight, Types 6 and 6P—Submersible, Type 7 (A, B, C & D) Explosionproof Class I, Division 1 Groups A, B, C, & D and Type 9 (E, F, & G)—Dust—Ignitionproof Class II, Division 1 Groups E, F & G. The Class II, Groups F & G Dust Locations designation is not applicable for solenoids or solenoid valves used for steam service or when a class "H" solenoid is used. See *Temperature Limitations* section for solenoid identification and nameplate/retainer for service. When installed just as a solenoid and not attached to an ASCO valve, the core has a 0.250-28 UNF-2B tapped hole, 0.38 or 0.63 minimum full thread.

Catalog numbers 8202G1, 8202G3, 8202G5 and 8202G7 are epoxy encapsulated push-type, reverse-acting solenoids having the same enclosure types as previously stated for Catalog numbers 8003G1 and 8003G2.

Series 8003G and 8202G solenoids are available in:

- **Open-Frame Construction:** The green solenoid may be supplied with 1/4" spade, screw or DIN terminals. (Refer to Figure 4)
- **Panel Mounted Construction:** These solenoids are specifically designed to be panel mounted by the customer through a panel having a .062 to .093 maximum wall thickness. Refer to Figure 1 and section on *Installation of Panel Mounted Solenoid*.

Optional Features For Type 1 — General Purpose Construction Only

- **Junction Box:** This junction box construction meets Enclosure Types 2, 3, 3S, 4, and 4X. Only solenoids with 1/4" spade or screw terminals may have a junction box. The junction box provides a 1/2" conduit connection, grounding and spade or screw terminal connections within the junction box. (See Figure 5)
- **DIN Plug Connector Kit No. K236034:** Use this kit only for solenoids with DIN terminals. The DIN plug connector kit provides a two pole with grounding contact DIN Type 43650 construction. (See Figure 6)

OPERATION

Series 8003G — When the solenoid is energized, the core is drawn into the solenoid base sub-assembly. **IMPORTANT:** When the solenoid is de-energized, the initial return force for the core, whether developed by spring, pressure, or weight, must exert a minimum force to overcome residual magnetism created by the solenoid. Minimum return force for AC construction is 11 ounces, and 5 ounces for DC construction.

Series 8202G — When the solenoid is energized, the disc holder assembly is pushed against the orifice. When the solenoid is de-energized, the disc holder assembly returns. **IMPORTANT:** Initial return force for the disc or disc holder assembly, whether developed by spring, pressure, or weight, must exert a minimum force to overcome residual magnetism created by the solenoid. Minimum return force is 1 pound, 5 ounces.

INSTALLATION

Check nameplate for correct catalog number, service, and wattage. Check front of solenoid for voltage and frequency.

▲ WARNING: To prevent the possibility of electrical shock from the accessibility of live parts, install the open-frame solenoid in an enclosure.

FOR BLACK ENCLOSURE TYPES 7 AND 9 ONLY

▲ CAUTION: To prevent fire or explosion, do not install solenoid and/or valve where ignition temperature of hazardous atmosphere is less than 165° C. On valves used for steam service or when a class "H" solenoid is used, do not install in hazardous atmosphere where ignition temperature is less than 180° C. See nameplate/retainer for service.

NOTE: These solenoids have an internal non-resettable thermal fuse to limit solenoid temperature in the event that extraordinary conditions occur which could cause excessive temperatures. These conditions include high input voltage, a jammed core, excessive ambient temperature or a shorted solenoid, etc. This unique feature is a standard feature only in solenoids with black explosionproof/dust-ignitionproof enclosures (Types 7 & 9).

▲ CAUTION: To protect the solenoid valve or operator, install a strainer or filter, suitable for the service involved in the inlet side as close to the valve or operator as possible. Clean periodically depending on service conditions. See ASCO Series 8600, 8601, and 8602 for strainers.

Temperature Limitations

For maximum valve ambient temperatures, refer to chart. The temperature limitations listed, only indicate maximum application temperatures for field wiring rated at 90°C. Check catalog number prefix and watt rating on nameplate to determine maximum ambient temperature. See valve installation and maintenance instructions for maximum fluid temperature. **NOTE:** For steam service, refer to *Wiring* section, *Junction Box* for temperature rating of supply wires.

| Watt Rating | Catalog Number Coil Prefix | Class of Insulation | Maximum † Ambient Temp. |
|-------------|------------------------------------|---------------------|-------------------------|
| 10.1 & 17.1 | None, FB, KF, KP, SC, SD, SF, & SP | F | 125°F (54°C) |
| 10.1 & 17.1 | HB, HT, KB, KH, SS, ST, SU | H | 140°F (60°C) |
| 11.6 & 22.6 | None, FB, KF, KP, SC, SD, SF, & SP | F | 104°F (40°C) |
| 11.6 & 22.6 | HB, HT, KB, KH, SS, ST, SU, & SV | H | 104°F (40°C) |

† Minimum ambient temperature -40° F (-40° C)

Positioning

This solenoid is designed to perform properly when mounted in any position. However, for optimum life and performance, the solenoid should be mounted vertically and upright to reduce the possibility of foreign matter accumulating in the solenoid base sub-assembly area.

Wiring

Wiring must comply with local codes and the National Electrical Code. All solenoids supplied with lead wires are provided with a grounding wire which is green or green with yellow stripes and a 1/2" conduit connection. To facilitate wiring, the solenoid may be rotated 360°. For the watertight and

explosionproof solenoid, electrical fittings must be approved for use in the approved hazardous locations.

▲ CAUTION: Cryogenic Applications – Solenoid lead wire insulation should not be subjected to cryogenic temperatures. Adequate lead wire protection and routing must be provided.

Additional Wiring Instructions For Optional Features:

- Open-Frame solenoid with 1/4" spade terminals.
For solenoids supplied with screw terminal connections use #12-18 AWG stranded copper wire rated at 90°C or greater. Torque terminal block screws to 10 ± 2 in-lbs [1.0 ± 1.2 Nm]. A tapped hole is provided in the solenoid for grounding, use a #10-32 machine screw. Torque grounding screw to 15-20 in-lbs [1.7-2.3 Nm]. On solenoids with screw terminals, the socket head screw holding the terminal block to the solenoid is the grounding screw. Torque the screw to 15-20 in-lbs [1.7-2.3 Nm] with a 5/32" hex key wrench.

• Junction Box

The junction box is used with spade or screw terminal solenoids only and is provided with a grounding screw and a 1/2" conduit connection. Connect #12-18 AWG standard copper wire only to the screw terminals. Within the junction box use field wire that is rated 90°C or greater for connections. For steam service use 105°C rated wire up to 50 psi or use 125°C rated wire above 50 psi. After electrical hookup, replace cover gasket, cover, and screws. Tighten screws evenly in a crisscross manner.

• DIN Plug Connector Kit No. K236034

1. The open-frame solenoid is provided with DIN terminals to accommodate the plug connector kit.
2. Remove center screw from plug connector. Using a small screwdriver, pry terminal block from connector cover.
3. Use #12-18 AWG stranded copper wire rated at 90°C or greater for connections. Strip wire leads back approximately 1/4" for installation in socket terminals. The use of wire-end sleeves is also recommended for these socket terminals. Maximum length of wire-end sleeves to be approximately 1/4". Tinning of the ends of the lead wires is not recommended.

4. Thread wire through gland nut, gland gasket, washer and connector cover.
NOTE: Connector housing may be rotated in 90° increments from position shown for alternate positioning of cable entry.

5. Check DIN connector terminal block for electrical markings. Then make electrical hookup to terminal block according to markings on it. Snap terminal block into connector cover and install center screw.

6. Position connector gasket on solenoid and install plug connector. Torque center screw to 5 ± 1 in-lbs [0.6 ± 1.1 Nm].

NOTE: Alternating current (AC) and direct current (DC) solenoids are built differently. To convert from one to the other, it may be necessary to change the complete solenoid including the core and solenoid base sub-assembly, not just the solenoid. Consult ASCO.

Installation of Solenoid

Solenoids may be assembled as a complete unit. Tightening is accomplished by means of a hex flange at the base of the solenoid.

Installation of Panel Mounted Solenoid (See Figure 1)

1. Disassemble solenoid following instruction under *Solenoid Replacement* then proceed.
2. Install solenoid base sub-assembly through customer panel.
3. Position spring washer on opposite side of panel over solenoid base sub-assembly.
4. Replace solenoid, nameplate/retainer and red cap.
5. Make electrical hookup, see *Wiring* section.

Solenoid Temperature

Standard solenoids are designed for continuous duty service. When the solenoid is energized for a long period, the solenoid becomes hot and can be touched by hand only for an instant. This is a safe operating temperature.

MAINTENANCE

▲ WARNING: To prevent the possibility of personal injury or property damage, turn off electrical power, depressurize solenoid operator and/or valve, and vent fluid to a safe area before servicing.

Cleaning

All solenoid operators and valves should be cleaned periodically. The time between cleaning will vary depending on medium and service conditions. In general, if the voltage to the solenoid is correct, sluggish valve operation, excessive noise or leakage will indicate that cleaning is required. Clean strainer or filter when cleaning the valve.

Preventive Maintenance

- Keep the medium flowing through the solenoid operator or valve as free from dirt and foreign material as possible.
- While in service, the solenoid operator or valve should be operated at least once a month to insure proper opening and closing.
- Depending on the medium and service conditions, periodic inspection of internal valve parts for damage or excessive wear is recommended. Thoroughly clean all parts. Replace any worn or damaged parts.

Causes of Improper Operation

- **Faulty Control Circuit:** Check the electrical system by energizing the solenoid. A metallic *click* signifies that the solenoid is operating. Absence of the *click* indicates loss of power supply. Check for loose or blown fuses, open-circuited or grounded solenoid, broken lead wires or splice connections.
- **Burned-Out Solenoid:** Check for open-circuited solenoid. Replace if necessary. Check supply voltage; it must be the same as specified on nameplate/retainer and marked on the solenoid. Check ambient temperature and check that the core is not jammed.
- **Low Voltage:** Check voltage across the solenoid leads. Voltage must be at least 85% of rated voltage.

Solenoid Replacement

1. Disconnect conduit, coil leads, and grounding wire.

NOTE: Any optional parts attached to the old solenoid must be reinstalled on the new solenoid. For 3-way construction, piping or tubing must be removed from pipe adapter.

2. Disassemble solenoids with optional features as follows:

• Spade or Screw Terminals

Remove terminal connections, grounding screw, grounding wire, and terminal block (screw terminal type only).

NOTE: For screw terminals, the socket head screw holding the terminal block serves as a grounding screw.

• Junction Box

Remove conduit and socket head screw (use 5/32" hex key wrench) from center of junction box. Disconnect junction box from solenoid.

• DIN Plug Connector

Remove center screw from DIN plug connector. Disconnect DIN plug connector from adapter. Remove socket head screw (use 5/32" hex key wrench), DIN terminal adapter, and gasket from solenoid.

3. Snap off red cap from top of solenoid base sub-assembly. For 3-way construction with pipe adapter (Figure 3), remove pipe adapter, nameplate and solenoid. Omit steps 4 and 5.

4. Push down on solenoid. Then using a suitable screwdriver, insert blade between solenoid and nameplate/retainer. Pry up slightly and push to remove.

NOTE: Series 8202G solenoids have a spacer between the nameplate/retainer and solenoid.

5. Remove solenoid from solenoid base sub-assembly.

6. Reassemble in reverse order of disassembly. Use exploded views for identification and placement of parts.

7. Torque pipe adapter to 90 inch-pounds maximum [10.2 Nm maximum]. Then make up piping or tubing to pipe adapter on solenoid.

Disassembly and Reassembly of Solenoids

1. Remove solenoid, see *Solenoid Replacement*.

2. Remove spring washer from solenoid base sub-assembly. For 3-way construction, remove plugnut gasket.

3. Unscrew solenoid base sub-assembly from valve body.

4. Remove internal solenoid parts for cleaning or replacement. Use exploded views for identification and placement of parts.

5. If the solenoid is part of a valve, refer to basic valve installation and maintenance instructions for further disassembly.

6. Torque solenoid base sub-assembly and adapter to 175 ± 25 in-lbs [19.8 ± 2.8 Nm].

ORDERING INFORMATION FOR ASCO SOLENOIDS

When Ordering Solenoids for ASCO Solenoid Operators or Valves, order the number stamped on the solenoid. Also specify voltage and frequency.

Torque Chart

| Part Name | Torque Value Inch-Pounds | Torque Value Newton-Meters |
|--------------------------------------|--------------------------|----------------------------|
| solenoid base sub-assembly & adapter | 175 ± 25 | $19,8 \pm 2,8$ |
| pipe adapter | 90 maximum | 10,2 maximum |

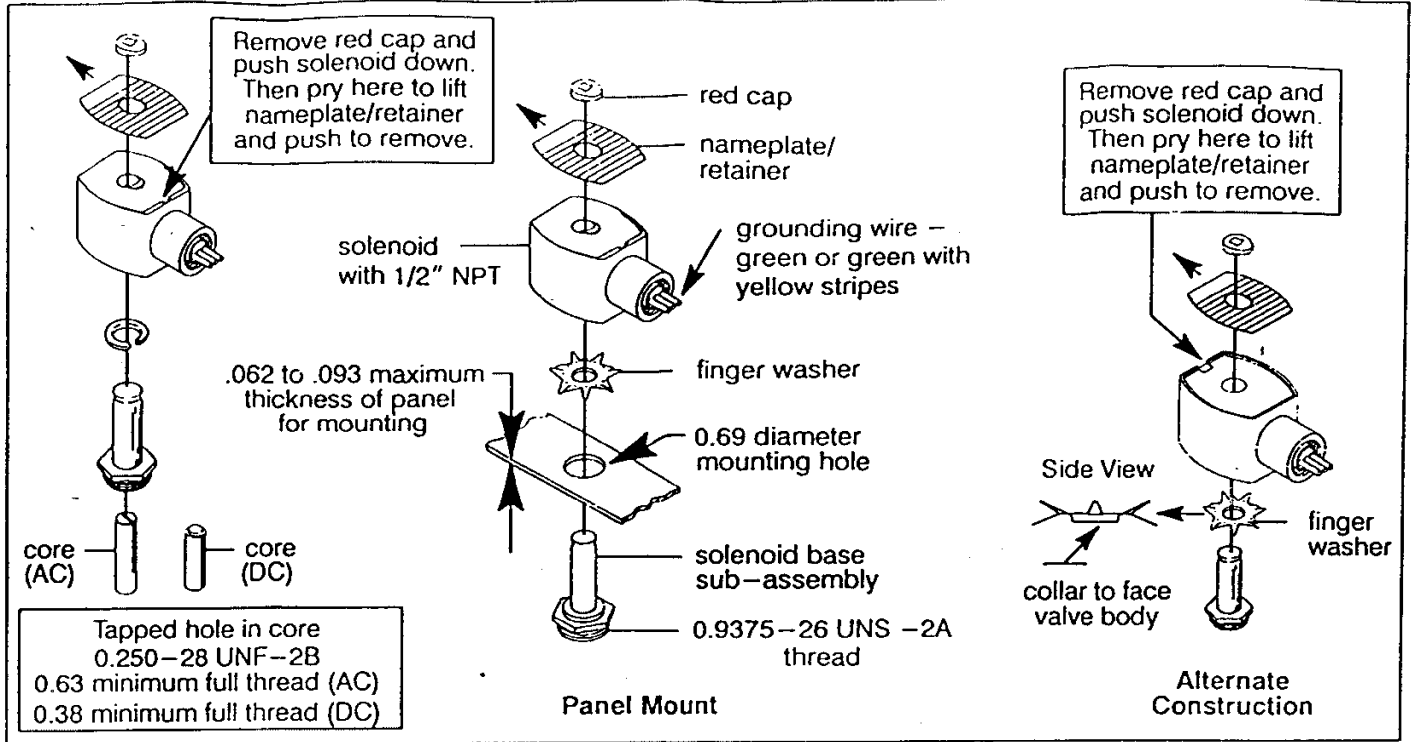

Figure 1. Series 8003G solenoids

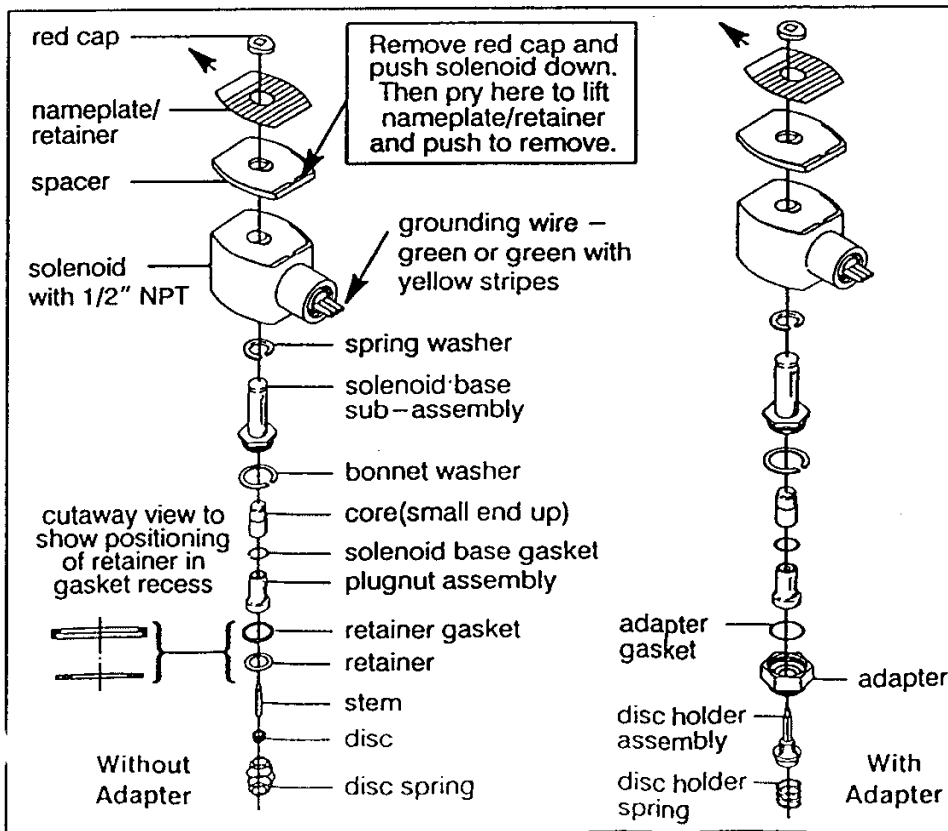

Figure 2. Series 8202G solenoids

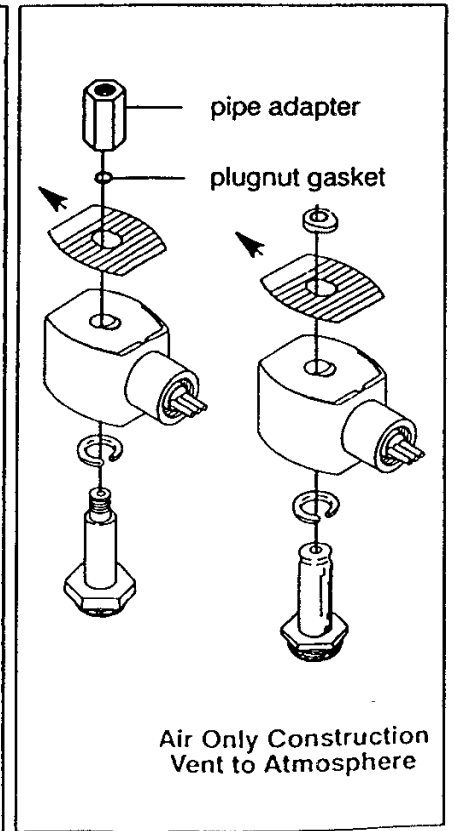
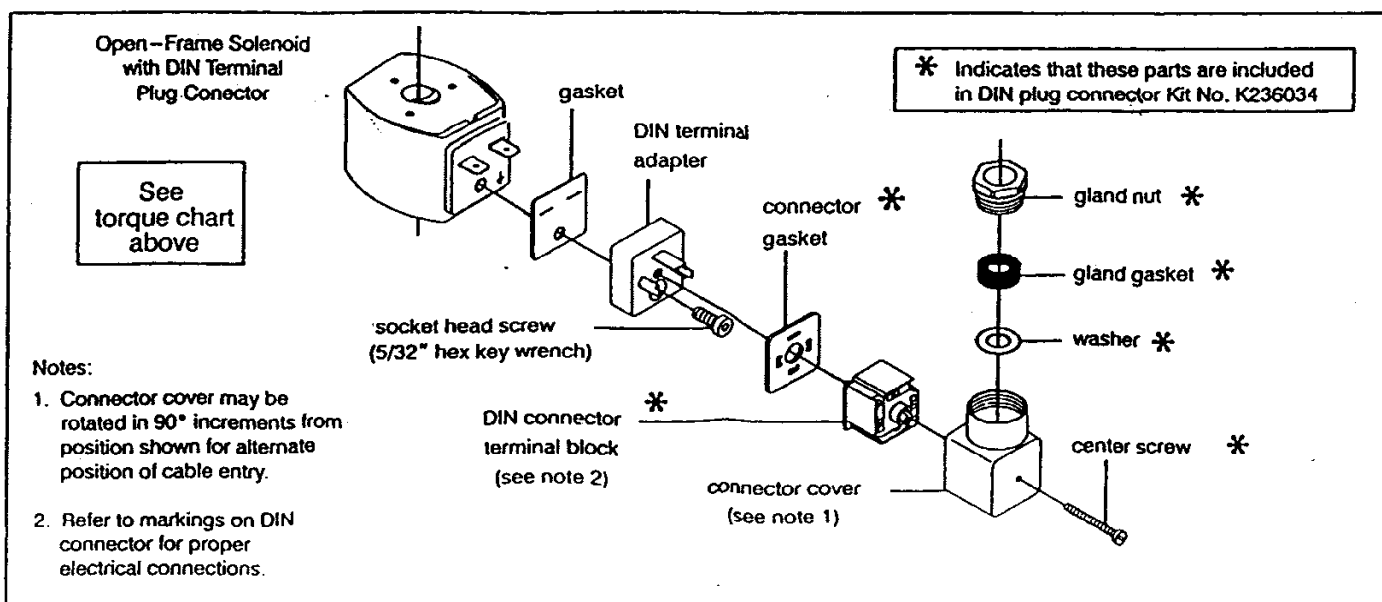
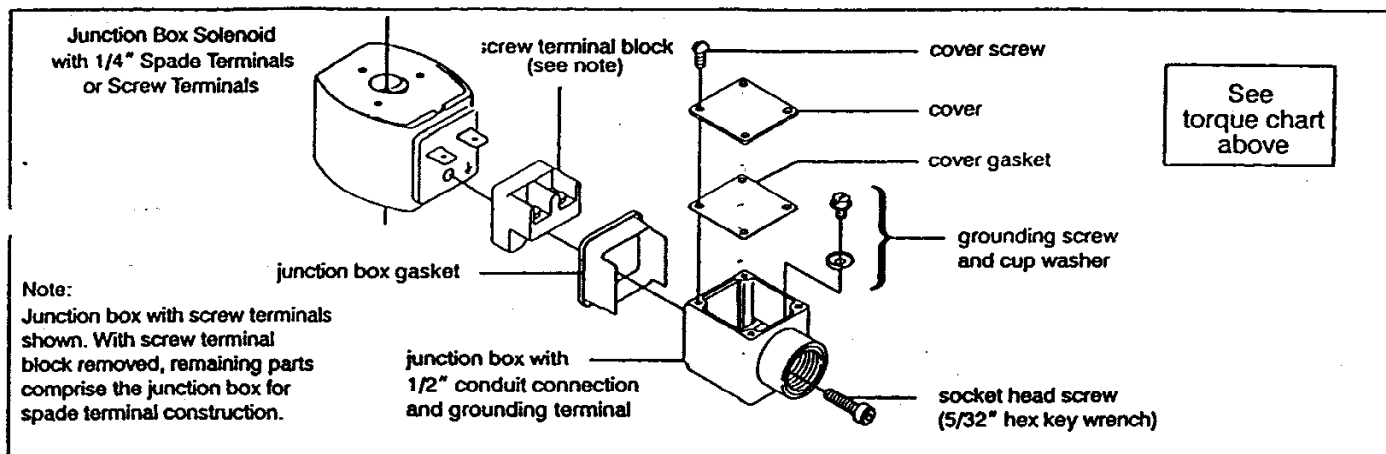
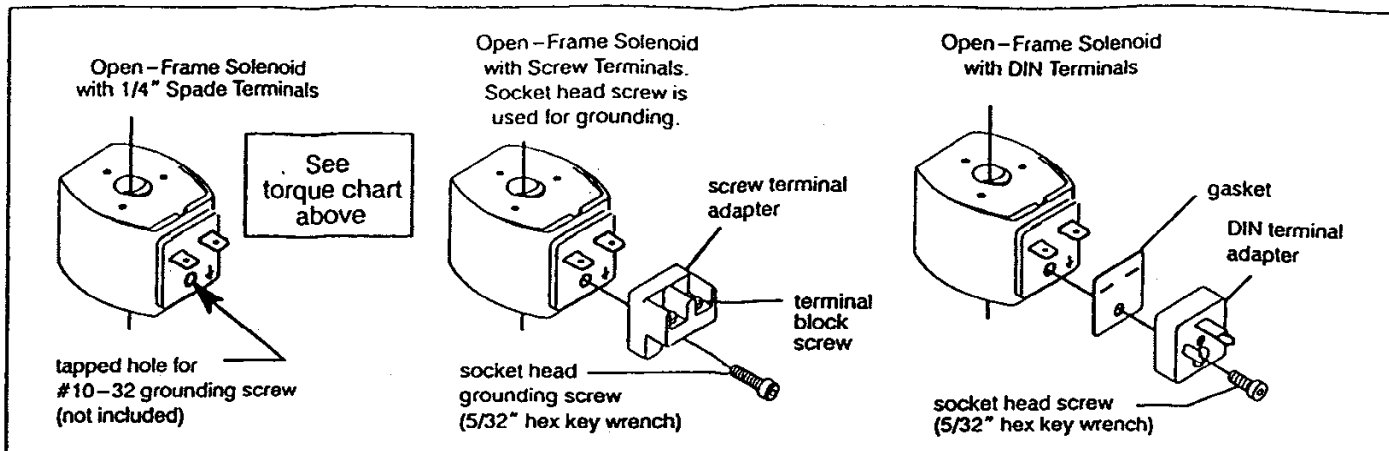

Figure 3. 3-Way Construction

Torque Chart

| Part Name | Torque Value in Inch-Pounds | Torque Value in Newton-Meters |
|-----------------------|-----------------------------|-------------------------------|
| terminal block screws | 10 ± 2 | $1,1 \pm 0,2$ |
| socket head screw | $15 - 20$ | $1,7 - 2,3$ |
| center screw | 5 ± 1 | $0,6 \pm 0,1$ |



Form No. V6584R5

SERIES 1500

INDUCTION CONTROL RELAYS

SERVICE BULLETIN

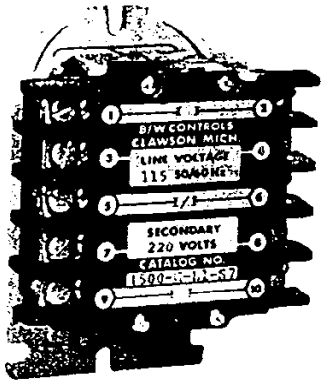

PRINCIPLE OF OPERATION

A BIW floatless liquid level control system consists of a relay of the proper type, a holder designed to support one or more electrodes or probes in the liquid container, and the corrosion resistant electrodes themselves. Inasmuch as all BIW induction relays are quite similar — differing only in contact arrangement, the following description of how a 1500-C Relay functions on a pump down control application will serve to explain the design, construction, and operating principles for the entire line.

As shown in diagrams below, the laminated core of the relay is **Π** shaped. The primary coil is assembled to the upper bar of the core, and the secondary coil for the electrode is placed on the lower bar. An armature located below the legs of the **Π** core is connected to an insulated arm carrying the movable contacts. When the armature is raised, these contacts close or open the motor and electrode circuits, depending upon whether the contacts are normally open or closed. (Contacts shown normally open in this example.)

When a source of alternating current is connected to the primary coil at terminals 3 and 4, the primary coil sets up a magnetic flux which — following the lines of least resistance — circulates through the shortest path. As shown in Figure 1, this is through the lower bar of the laminated core on which the secondary coil is mounted. This magnetic flux induces a voltage in the secondary or electrode circuit coil. No current can flow in this coil, however, until the circuit is completed between the electrodes. Thus, the electrode circuit voltage being generated within the relay has no connection with the power line.

The BIW 1500 induction relay utilizes the liquid as an electrical conductor to complete the secondary circuit between the upper and lower electrodes. Thus, when the liquid contacts the upper electrode, the resulting flow of current in this circuit sets up a bucking action in the lower bar of the core. This action tends to divert lines of magnetic force to the core legs and sets up an attraction that pulls the armature into contact with the legs, as shown in Figure 2. This armature movement closes the electrode and load contacts.

The lower contacts on 1500-C Relays (terminals 9 and 10) connect the secondary circuit to ground when liquid contacts the upper electrode and act as a holding circuit to maintain the relay in its closed position until the liquid falls below the lower electrode. This holding circuit provides control of the relay over any desired range in the liquid level, depending on the distance between the upper and lower electrodes.

The flow of current through the low energy secondary circuit is very small and varies with the voltage of the secondary coil. The secondary coil is selected to operate over the resistance of the liquid being controlled. Accordingly, since there is a wide range of secondary coils from which to choose, it is important that complete information regarding the nature of the liquid be furnished when ordering B/W induction relays.

1500-C RELAY USED FOR PUMP DOWN CONTROL

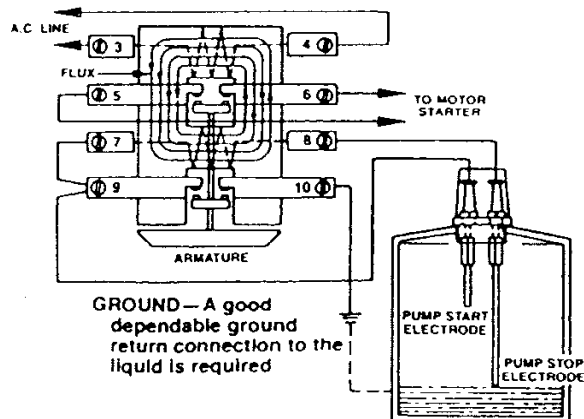

Figure 1 — Secondary coil circuit open; armature down.

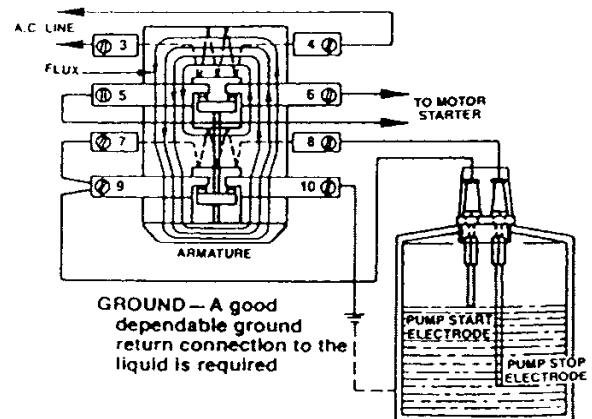

Figure 2 — Secondary coil circuit closed; armature up.

Service Instructions

BIW relays are designed and built to require a minimum of service in the field. Each one is tested and adjusted at the factory to insure positive operation and should not be altered or tampered with prior to installation. If a relay does not operate properly after it has been installed, the following information will be helpful in determining the probable cause.

ⓐ RELAY WILL NOT PULL IN

If relay will not pull in when liquid contacts upper electrode, failure to operate is probably caused by one of the following conditions:

1. Power Failure — A power failure to relay can be caused by broken wire, blown fuse, an open switch, loose screw, corroded connection, etc. Check for power failure with voltmeter or test light directly on relay line terminals (No. 3 and 4 on all BIW relays). Also check voltage at motor starter line terminals and overload heaters on motor starter to be sure they have not tripped.

2. Open Coils — Coils used in BIW relays very rarely fail unless struck by lightning or subjected to some severe over-voltage condition. To check coils, disconnect electrode connections from relay terminals, apply line voltage to the primary coil, and touch both ends of secondary coil with an insulated jumper wire. Relay should pull in when the jumper is connected and fall out when jumper is removed. Failure to do so indicates that one of the coils is open. If an open coil is found, contact dealer or the factory for a replacement relay.

3. Poor Ground Connections — BIW induction relays that operate from a single electrode — i.e., Types 1500-A, C, B, E and D — will not function unless a good dependable ground connection is made to complete the secondary circuit from one end of the secondary coil through the electrode and liquid, and back through ground to the other side of the secondary coil. If such a relay does not operate when liquid contacts the electrode, check ground connection to be sure it complies with Installation Instructions.

4. Broken Wires — A broken wire from relay to either electrode will prevent relay from operating. Broken wires can be checked by shorting the upper and lower electrode leads together at the electrode holder. If relay fails to pull in, one or both of the electrode leads is open. The individual leads can then be checked by running a temporary wire from the relay to holder outside conduit. If relay pulls in, it may be assumed that break is between the holder and the electrodes. This can be checked by shorting between the electrode tips with an insulated jumper.

5. Low Secondary Voltage — If the secondary coil voltage is too low for the resistance or conductivity of the liquid being controlled, the relay will not pull in — or it will buzz and chatter before pulling in. In either case, the relay should be replaced with one which has a higher voltage secondary coil. (See Table.) If in doubt about proper coil selection, furnish factory with details on liquid — or send sample for test.

6. Fouled Electrodes — Accumulation of dirt, grease or other deposits on the upper electrode will insulate it and prevent relay from pulling in.

If this occurs, the electrodes should be inspected and cleaned at regular intervals as required to eliminate the difficulty. If unusual quantities of oil, grease, or sludge are encountered, the electrodes can be mounted inside a pipe that is flushed with clean water. A 4" pipe should be used — with the bottom located below the lowest water level, and vent holes provided at top so that the level inside and outside the pipe will be the same. A small flow of water entering the top of the pipe will cause an outward flow of water from the bottom of the pipe and prevent undesirable material from entering. Thus, the electrodes will have a clear surface on which to operate and will stay clean.

7. Electrodes Too Short — It is possible for an installation to be completed in which the upper electrode is suspended at a point where the liquid cannot make contact. All installations should, of course, be checked to make sure that proper electrode lengths are provided.

ⓑ NOISY RELAY OPERATION

If the relay functions properly but is noisy in operation, it could be caused by the following:

1. Poor Electrode Connections — If wire suspended electrodes are used — and have either been lost or not properly connected — resultant increase in resistance in secondary circuit may cause relay to buzz or chatter in operation. This condition can be corrected by checking to see that proper electrode connections are made. Excessive accumulation of dirt, grease or other deposits on the electrodes can also result in noisy relay operation — in which case periodic cleaning will eliminate the problem.

2. Low Secondary Voltage — If resistance of the liquid being controlled is at the upper end of the sensitivity range of the relay secondary coil, noisy operation may result. Sensitivity may be increased slightly by interchanging the ground and lower electrode connections at the relay. If this does not correct the condition, the relay should be replaced with one having a higher voltage secondary coil.

ⓒ ONE LEVEL OPERATION

If a relay operates at one level only — starting and stopping at one electrode, check following:

1. Electrode Wires — If wires between relay and electrodes are interchanged, relay will not operate over range in level but from upper electrode only. To correct, simply reverse connections — either at relay or at electrodes.

2. Ground Connection — Poor ground connection will prevent holding circuit from functioning and cause relay to operate from the upper electrode only. This can be easily corrected by making sure that ground connections conform with Installation Instructions.

3. Holding Circuit — If the holding circuit is not closing, the relay will operate from the upper electrode only. Since the holding circuit contact carries only a small current, a slight film of grease or dirt can sometimes prevent proper closure. To correct, rub contact surface with a clean paper. Do not use sand paper or emery cloth.

4. Upper Electrode Lead — A ground in lead wire to the upper electrode will cause relay to operate from lower electrode only. This condition can be checked out as described below.

ⓓ RELAY WILL NOT DROP OUT

If relay will not drop out when liquid falls below lower electrode, check the following points:

1. Lower Electrode Lead — A ground in the lead wire from relay to lower electrode will prevent relay from dropping out on low liquid level. If distance from holder to relay is relatively short, the best way to check for a ground is to connect a replacement wire from relay to the electrode holder outside the conduit and test the relay for operation. If it drops out properly it is safe to assume that a ground exists in the original lower electrode lead wire.

If relay is located a considerable distance from electrode holder, check for ground as follows: Disconnect power to relay. Remove wires from terminals in electrode holder and allow them to stick up to eliminate possibility of contacting a grounded part. Then turn on power to relay. If relay pulls in, a short is indicated between the electrode leads, from both electrodes to ground, or secondary coil is shorted internally. If relay does not pull in, short secondary coil with piece of insulated wire by bridging between relay terminal connections for upper and lower electrodes. Relay should pull in when this connection is made and drop out when connection is broken. If relay does not drop out, a short to ground is indicated in lower electrode lead. This ground may not be enough to pull in relay, but it can be sufficient to hold relay in once it has been closed in normal operation.

If any of these conditions exist, disconnect power to relay and replace grounded wires.

2. Electrode Holder — Excessive dirt or moisture over insulation at electrode holder or electrodes can cause faulty relay operation. Interior of electrode holder and its underside should be kept clean and dry. Conduit connections should be made so that no condensation can enter holder. Underside of vertically mounted holders should never come in contact with the liquid. Insulated rod electrodes should be used with horizontally mounted holders.

Electrodes should be kept relatively clean and free of dirt or grease. Check them periodically to make sure they do not become fouled with floating debris or insulating deposits.

3. Length of Lead Wires — On installations with excessive distance — over 900 feet — between relay and tank, relay may tend to hold in due to capacitance in electrode lines and fail to drop out when liquid leaves lower electrode. Since there are a number of ways to achieve reliable long distance control, complete information regarding such applications should be submitted to factory for recommendations.

CAUTION

Be sure to disconnect relay control power before servicing electrodes or electrode holders.

Installation Instructions

Relay: Install relay in level upright position. Connect wires from AC supply to terminals #3 and #4 on relay. Make sure power is of same rated voltage and frequency as shown for connection to primary coil on relay data plate. Relays draw 9 volt amperes.

Electrodes: Install electrodes in tank or well by suspending them vertically from an electrode holder or some other suspending means. One electrode should be set at desired start level and one at desired stop level. For sewage or surface drainage sumps, make sure electrodes are hung far enough apart so that foreign matter floating on water cannot foul electrodes. Size 18 or larger Type TW or THW wire is recommended for connection to the relay.

CAUTION — Although the electrodes are connected to a low energy secondary coil output which has inherently low current, there may be up to 800 volts between the electrodes or from an electrode to ground. (See Secondary Coil Table.) Thus wiring and electrodes should be installed to protect personnel from accidental contact.

Ground: A system ground return circuit is required from the indicated relay terminal to the liquid in order to complete the secondary circuit of relay. *Conduit should not be used.* Instead, connection should be made directly to uninsulated metal tank, or to metal pipe connected to tank below normal low liquid level. In wells, connect ground to pump or metallic water pipe. For concrete, wood, or insulated tanks, use an extra common electrode extending slightly below the longest operating electrode.

Secondary Coil: Because the secondary voltage on all BIW relays is an induced voltage generated within the relay itself, the secondary coil should never be connected to any source of power. Voltage of the secondary coil installed on a given relay is determined by conductivity of liquid to be controlled.

Load Connections: BIW relays are two-wire control devices having load contacts rated at 1 hp., single-phase, 115 or 230 volts AC or standard duty pilot rating up to 600 volts AC. In operation, load contacts act as a switch to open or close a circuit. Connecting them to an external load does not introduce a source of alternating current into the circuit.

Accordingly, in making connections for direct operation of single-phase loads within rated capacity of relay, power connections must be made as shown in relay wiring diagram.

To operate higher rated single-phase loads or three-phase loads, a magnetic starter must be used. In making connections to motor starter, follow directions given on the starter wiring diagram for connecting two-wire control devices.

DISCOUNT SCHEDULE LL1
Prices Subject to Change without Notice

FIELD CONVERTIBLE CONTACTS PROVIDES NEW CIRCUIT VERSATILITY

The all new Series 1500 Induction Relay can have contacts easily added and/or changed from N.O. to N.C. or N.C. to N.O.

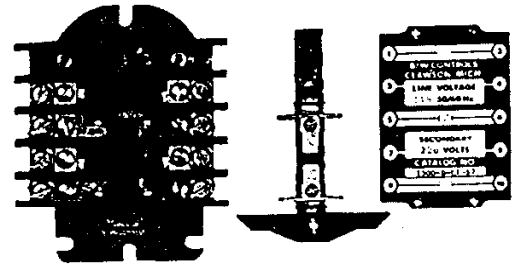

Remove cover plate and armature

For a N.O. contact, install the moveable contact in the armature assembly facing toward the top of the relay (away from the armature).

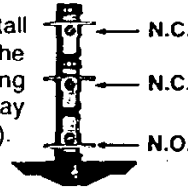

ARMATURE

For a N.C. contact, install the moveable contact in the armature assembly facing toward the bottom of the relay (toward the armature).

CONTACT KIT

PART NO. 15-000001 \$13.00 LIST

LESS DISCOUNT SCHEDULE LL

N.O. CONTACT



For a N.O. contact, install the stationary contacts facing toward the bottom of the relay (toward the armature).

N.C. CONTACT



For a N.C. contact, install the stationary contacts facing toward the top of the relay (away from the armature).

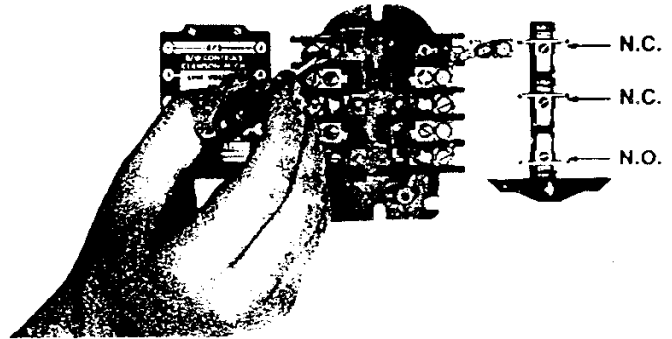

| | CONTACT ARRANGEMENT CODE | | | | | | | | | |
|------------------------------------|--------------------------|----------|----------|-----------------|----------|----------|-----------------|-----------------|----------|----------|
| | A 1NB | B 1NC | C 2NB | D 1NB 1NC | E 2NC | F 1NB | G 2NB 1NC | H 1NB 2NC | I 1NC | J 1NC |
| TOP CONTACT TERMINALS 1 & 2 | - | - | - | - | - | - | - | - | - | - |
| MIDDLE CONTACT TERMINALS 5 & 6 | - | - | - | - | - | - | - | - | - | - |
| BOTTOM CONTACT TERMINALS 9 & 10 | - | - | - | - | - | - | - | - | - | - |

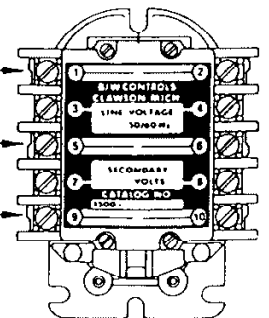

CONTACT RATINGS

25 Amp Resistive at 120, 240, or 480 VAC
1 HP Single Phase at 120 or 240 VAC
Heavy Duty Pilot 120 to 600 VAC
2 Amp Resistive at 120 VDC
10 Amp Resistive at 48 VDC

| INDUCTION RELAY CONTACT ARRANGEMENT | WIRING DIAGRAM AND OPERATION | | TYPICAL APPLICATIONS |
|--|------------------------------|-----------------|--|
| | DIRECT OPERATION | PILOT OPERATION | |
| 1500-A RELAY Contact Arrangement Normally Open Normally Closed Holding Circuit 1 0 0 | | | High Level Signal Control. Low Level Cutoff when wired in series with Stop button in 3-wire pushbutton stations. Remote, long distance and low voltage manual control applications, etc. (Similar to 1100-L) |
| 1500-C RELAY Contact Arrangement Normally Open Normally Closed Holding Circuit 2 0 0 | | | Same as 1500-A Relay above except that an additional Normally Open contact is provided to permit simultaneous operation of different types of secondary signal devices in remote locations. (Similar to 1100-2L) |
| 1500-B RELAY Contact Arrangement Normally Open Normally Closed Holding Circuit 0 1 0 | | | Low Level Signal Control. High Level Cutoff when wired in series with Stop button in 3-wire pushbutton stations. Remote, long distance and low voltage manual control applications, etc. (Similar to 1100-R) |
| 1500-E RELAY Contact Arrangement Normally Open Normally Closed Holding Circuit 0 2 0 | | | Same as 1500-B Relay above except that an additional Normally Closed contact is provided to permit simultaneous operation of different types of secondary signal devices in remote locations. (Similar to 1100-2R) |
| 1500-D RELAY Contact Arrangement Normally Open Normally Closed Holding Circuit 1 1 0 | | | High or Low Level Signal Control. High or Low Level Cutoff when wired in series with Stop button in 3-wire pushbutton stations. Can also be used to interlock various types of signal devices. (Similar to 1100-D) |
| 1500-C RELAY Contact Arrangement Normally Open Normally Closed Holding Circuit 1 0 1 | | | Pump Down Control for sewage and sump pumps, condensate return system, etc. Low Level Cutoff for submersible pumps. Normally closed Solenoid Valve Control for discharging liquids from tanks, etc. (Similar to 1100-LH) |
| 1500-F RELAY Contact Arrangement Normally Open Normally Closed Holding Circuit 2 0 1 | | | Same as 1500-C Relay above except that additional Normally Open contact is provided to permit simultaneous operation of second pump. Extra contact can also be used for signal purposes if desired. (Similar to 1100-2LH) |

CAUTION: Electrodes are terminals of live electrical circuits and must be installed to prevent accidental contact by personnel. Control power must be disconnected before servicing.

A good dependable ground return connection to the liquid is required.

| INDUCTION RELAY CONTACT ARRANGEMENT | WIRING DIAGRAM AND OPERATION | | TYPICAL APPLICATIONS |
|--|------------------------------|-----------------|---|
| | DIRECT OPERATION | PILOT OPERATION | |
| J-D RELAY Contact Arrangement Normally Open Normally Closed Holding Circuit 0 1 1 | | | Pump Up Control for supply pumps on elevated tanks and towers, carbonators, etc. High Level Cutoff for pumps and valves. Normally closed Solenoid Valve Control for plating tank and boiler make-up, etc. (Similar to 1100-RH) |
| 1500-H RELAY Contact Arrangement Normally Open Normally Closed Holding Circuit 0 2 1 | | | Same as 1500-D Relay above except that additional Normally Closed contact is provided to permit simultaneous operation of second pump. Extra contact can also be used for signal purposes if desired. (Similar to 1100-2RH) |
| 1500-G RELAY Contact Arrangement Normally Open Normally Closed Holding Circuit 1 1 1 | | | Pump Up or Pump Down Control for same applications listed above for B/W 1500-C and 1500-D Relays. It is also suitable for use in controlling hydropneumatic tanks and motorized valve installations. (Similar to 1100-DH) |

CAUTION: Electrodes are terminals of live electrical circuits and must be installed to prevent accidental contact by personnel. Control power must be disconnected before servicing.

A good dependable ground return connection to the liquid is required.

CATALOG NUMBERING SYSTEM

1500 — A — L1 — S7

Catalog Section

| | CONTACT ARRANGEMENTS | |
|---|----------------------|-----------------|
| | NORMALLY OPEN | NORMALLY CLOSED |
| A | 1 | 0 |
| B | 0 | 1 |
| C | 2 | 0 |
| D | 1 | 1 |
| E | 0 | 2 |
| F | 3 | 0 |
| G | 2 | 1 |
| H | 1 | 2 |
| J | 0 | 3 |

| LINE VOLTAGE | |
|--------------|------------------------|
| L1 | 110-120 Volts 50/60 HZ |
| L2 | 208-240 Volts 50/60 HZ |
| L3 | 440-480 Volts 50/60 HZ |
| L4 | 550-600 Volts 50/60 HZ |

Consult Factory For Special Line Voltages Not Listed.

| | SECONDARY COIL VOLTAGE | TYPICAL LIQUIDS |
|-----|------------------------|---|
| S1 | 12 Volts A.C. | Metallic circuits |
| S2 | 24 Volts A.C. | Metallic circuits |
| S3 | 40 Volts A.C. | Acid or caustic solutions; Milk; Brine and salt solutions; Plating solutions; Buttermilk; Soups. |
| S4 | 90 Volts A.C. | Weak acid or caustic solutions; Beer; Baby foods; Fruit juices. |
| S7 | 220 Volts A.C. | Sewage; Most water-except very soft; Pottery slip; Water soluble oil solutions; Starch solutions. |
| S8 | 360 Volts A.C. | Very soft water; Sugar syrup. |
| S9 | 480 Volts A.C. | Steam condensate; Strong alcohol solutions. |
| S11 | 800 Volts A.C. | Deminerlized or distilled water. |
| S1Z | 12 Volts A.C. | 17 Volt D.C. Sensing Circuit |
| S2Z | 24 Volts A.C. | 34 Volt D.C. Sensing Circuit |
| S3Z | 40 Volts A.C. | 56 Volt D.C. Sensing Circuit |

All contacts rated at:
 25 Amp Resistive at 120, 240, or 480 VAC
 1 HP Single Phase at 120 or 240 VAC
 Heavy Duty Pilot 120 to 600 VAC
 2 Amp Resistive at 120 VDC
 10 Amp Resistive at 48 VDC

SERIES 1500

INDUCTION CONTROL RELAYS

SERVICE BULLETIN

CONDUCTIVE LIQUIDS

With the exception of products such as oil, gasoline, animal fats and other similar products, most liquids and some moist bulk materials have sufficient conductivity to use BIW level detecting relays. The Series 1500 relay can be used on liquids with resistance up to about 90,000 ohm-cm (conductivity to 11 micromho/cm). For liquids with higher resistance the BIW Series 52 relay described in Catalog Section 5200 must be used for applications up to 12 megohms resistance. The vapor above some liquids is considered an explosive hazard and in these cases the BIW Series 53 relay with FM approved intrinsically safe sensing circuit should be used. See Catalog Section 5300.

Liquids such as milk and beer, and some pharmaceutical products will foam during processing. The liquid phase is always a better conductor than the foam, and when the interface level is to be detected, the relay sensitivity must be carefully selected and it would be well to check the factory for our recommendation.

With nearly 50 years of experience BIW has compiled a history of applications in most major industries around the world. If you have questions regarding the proper relay selection, write us, phone us, or send a sample for test. Chances are that we have the answer for you.

TYPICAL LIQUIDS

The following recommendations are satisfactory for general use, but because the conductivity of liquids varies greatly with concentration, purity, temperature and other factors, some applications may require a different selection.

A number of the products listed are produced as solids such as crystals or powders, and our relay selection is based on the normally used commercial solutions of these materials.

| Liquid Description | Secondary Coil |
|---------------------------------|--------------------------|
| Acetic Acid — Up to 75% | 90 Volt |
| — 75 to 90% | 220 Volt |
| — Glacial | Use 5200-H Relay |
| Acetone | Use 5200-H or 5300 Relay |
| Acids — General | 40 or 90 Volt |
| — Anhydrous | Use 5200-H Relay |
| Alcohols | Use 5200-H or 5300 Relay |
| Alkalies — General | 40 or 90 Volt |
| — Anhydrous | Use 5200-H Relay |
| Alum Solutions | 220 Volt |
| Aluminum Sulphate | 90 Volt |
| Aluminum Hydroxide | 90 Volt |
| Amino Acids | 90 Volt |
| Ammonia-Anhydrous Liquid | Use 5200-H Relay |
| Ammonium Chloride | 40 Volt |
| Ammonium Hydroxide (Ammonia) | 220 Volt |
| Ammonium Nitrate | Use 5300 Relay |
| Ammonium Sulphate | 220 Volt |
| Baby Foods | 90 Volt |
| Barium Chloride | 40 Volt |
| Barium Nitrate | 40 Volt |
| Beer | 90 Volt |
| Black Liquor | 40 Volt |
| Blood | 220 Volt |
| Borax — Up to 10% | 220 Volt |
| — Greater than 10% | 90 Volt |
| Boric Acid | 220 Volt |
| Bread Dough | 90 Volt |
| Buttermilk | 24 or 40 Volt |
| Cadmium Chloride | 40 Volt |
| Cake Batter | 220 Volt |
| Calcium Chloride | 40 Volt |
| Calcium Hydroxide | 220 Volt |
| Carbolic Acid — Up to 90% | 220 Volt |
| — 90 to 100% | Use 5200-H Relay |
| Catsup | 90 Volt |
| Caustic Soda (Sodium Hydroxide) | 40 Volt |
| Cement Slurry | 220 Volt |
| Chromic Acid | 40 Volt |
| Citric Acid | 40 or 90 Volt |
| Coffee | 90 Volt |
| Condensate — Ordinary Water | 480 Volt |
| — D. I. Water | Use 5200-H Relay |
| Corn Syrup | 480 Volt |
| Corn — Cream Style | 90 Volt |
| Ethylene Glycol | Use 5200-H Relay |
| Ferric Chloride | 90 or 220 Volt |
| Ferrous Sulphate | 220 Volt |

| Liquid Description | Secondary Coil |
|---------------------------------|--------------------------|
| Formaldehyde | Use 5200-H Relay |
| Formic Acid — Up to 75% | 90 Volt |
| — 75 to 90% | 220 Volt |
| Glycerine (Glycerol) | Use 5200-H Relay |
| Hydrochloric Acid | 40 Volt |
| Hydrofluoric Acid — Up to 20% | 220 Volt |
| — Above 20% | 40 Volt |
| Hydrofluorsilicic Acid | 90 Volt |
| Hydrogen Peroxide | Use 5200-H or 5300 Relay |
| Jams & Jellies | 360 Volt |
| Juices — Fruit & Vegetable | 40 or 90 Volt |
| Lemon Oil Essence | Use 5200-H Relay |
| Lignite | 800 Volt |
| Lithium Chloride | 40 Volt |
| Magnesium Hydroxide | 90 Volt |
| Mayonnaise | 220 Volt |
| Methanol | Use 5200-H or 5300 Relay |
| Methyl Ethyl Keystone (MEK) | Use 5200-H Relay |
| Milk | 40 Volt |
| Molasses | 220 Volt |
| Muriatic Acid | 40 Volt |
| Mustard | 40 Volt |
| Nitric Acid | 40 or 90 Volt |
| Orange Juice | 90 Volt |
| Paper Stock | 220 Volt |
| Penicillin | 220 Volt |
| Phosphoric Acid | 40 Volt |
| Plating Solutions | 40 or 90 Volt |
| Salts — Chemical | 40 or 90 Volt |
| Sodium Carbonate (Soda Ash) | 90 Volt |
| Sodium Chloride (Table Salt) | 40 Volt |
| Sodium Hydroxide (Caustic Soda) | 40 Volt |
| Sodium Hypochlorate | 40 Volt |
| Sodium Silicate (Water Glass) | 90 Volt |
| Soups | 40 Volt |
| Starch Solutions | 220 Volt |
| Sugar — Low Concentrations | 220 Volt |
| — High Concentrations | 360 Volt |
| Sulphuric Acid | 40 Volt |
| Vinegar | 90 Volt |
| Water — Sea | 40 Volt |
| — Ordinary Potable | 220 Volt |
| — Ordinary Soft | 360 Volt |
| — Ordinary Condensate | 480 Volt |
| — Purified Distilled | 800 Volt or 5200-H Relay |
| — Purified Deionized | Use 5200-H Relay |
| Zinc Chloride | 40 Volt |



**CONTINENTAL
EQUIPMENT CORP.**

TEL: (414) 463-0500

FAX: (414) 463-3199

P.O. Box 18662

6103 N. 76th Street

Milwaukee, WI 53218

WARRANTY

1. We warrant that our products will be free of defects in material and workmanship for a period of (18) months from the date of shipment or (12) months from the date of installation, whichever is earlier. Components returned transportation prepaid to our plant and found to be defective, will be repaired or replaced at our option, free of charge and returned lowest cost freight prepaid. Premium transportation will be used at the buyers request and expense.
2. Warranties on components and equipment nor of our manufacture are limited to the terms of warranties furnished by our suppliers. Any defect in workmanship of any one part shall not condemn the entire machine.
3. This warranty does not cover conditions caused by misuse, negligence, alteration, accident, lack of reasonable and proper maintenance or other conditions beyond the control of the seller.
4. There are no representations, warranties or conditions; expressed or implied, statutory or otherwise, except those herein contained.