



Visit www.clevelandrange.com to locate a service or sales representative in your area.



DCTI
KE53479-1

Mixing Kettles - Gas, Horizontal Agitator

Installation, Operation, Maintenance, Parts & Service

This manual is updated as new information and models are released. Visit our website for the latest manual.

Model #s -

HA-MKGL-60	HA-MKGL-60-CC	HA-MKGL-60-T	HA-MKGL-60-CC-T
HA-MKGL-80	HA-MKGL-80-CC	HA-MKGL-80-T	HA-MKGL-80-CC-T
HA-MKGL-100	HA-MKGL-100-CC	HA-MKGL-100-T	HA-MKGL-100-CC-T

For your future reference.

Model # _____

Serial # _____



Read the manual thoroughly.
Improper installation, operation or maintenance can cause property damage, injury or death.

TABLE OF CONTENTS

Statement of Responsibilities	1
For your safety	2
Installation	4
Operating Instructions	6
Cleaning Instructions	10
Preventative Maintenance	13
Trouble Shooting & Maintenance	14
Service Parts	31



STATEMENT OF RESPONSIBILITIES / DÉCLARATION DES RESPONSABILITÉS / DECLARACIÓN DE RESPONSABILIDADES

This document is for use by experienced and trained Qualified Cleveland Range, LLC Authorized Service Representatives who are familiar with both the safety procedures, and equipment they service. Cleveland Range, LLC assumes no liability for any death, injury, equipment damage, or property damage resulting from use of, improper use of, or failure to use the information contained in this document. Cleveland Range, LLC has made every effort to provide accurate information in this document, but cannot guarantee that this document does not contain unintentional errors and omissions.

The information in this document may be subject to technical and technological changes, revisions, or updates. Cleveland Range, LLC assumes no liability or responsibility regarding errata, changes, revisions, or updates.

Qualified Cleveland Range, LLC Authorized Service Representatives are obligated to follow industry standard safety procedures, including, but not limited to, OSHA regulations, and disconnect / lock out / tag out procedures for all utilities including steam, and disconnect / lock out / tag out procedures for gas, electric, and steam powered equipment and / or appliances.

All utilities (gas, electric, water and steam) should be turned OFF to the equipment and locked out of operation according to OSHA approved practices during any servicing of Cleveland Range equipment

Qualified Cleveland Range, LLC Authorized Service Representatives are obligated to maintain up-to-date knowledge, skills, materials and equipment.

Ce document est destiné à l'usage des Représentants de Service qualifiés et autorisés de Cleveland Range, LLC qui possèdent l'expérience et la formation ainsi que la bonne connaissance des mesures de sécurité et du matériel qu'ils entretiennent.

Cleveland Range, LLC décline toute responsabilité pour tout cas de décès, blessure, dommage matériel ou dommage aux biens résultant de l'utilisation, de la mauvaise utilisation ou du manquement d'utilisation des renseignements contenus dans ce document.

Cleveland Range, LLC s'est efforcé à fournir des renseignements précis dans ce document mais ne peut garantir que ce document soit exempt d'erreurs et d'omissions non intentionnelles.

Les renseignements contenus dans ce document peuvent être assujettis à des changements techniques et technologiques, des révisions ou des mises à jour.

Cleveland Range, LLC décline toute obligation ou responsabilité concernant les errata, modifications, révisions ou mises à jour.

Les Représentants de Service qualifiés et autorisés de Cleveland Range, LLC sont tenus de se conformer aux mesures de sécurité normalisées de l'industrie, y compris, mais sans s'y limiter, les réglementations de l'OSHA, les procédures de débranchement / verrouillage / étiquetage relatives à tous les services publics, dont l'approvisionnement en vapeur, et les procédures de débranchement / verrouillage / étiquetage relatives aux équipements et/ou appareils fonctionnant au gaz, à l'électricité et à la vapeur.

Au cours de tout entretien d'un appareil Cleveland Range, tous les services publics (gaz, électricité, eau et vapeur) doivent être FERMÉS au niveau de l'appareil et le dispositif de fonctionnement doit être verrouillé suivant les pratiques approuvées de l'OSHA.

Les Représentants de Service qualifiés et autorisés de Cleveland Range, LLC sont tenus d'actualiser en permanence leurs connaissances, compétences, matériel et équipement.

Este documento está destinado para el uso de los Representantes de Servicio calificados y autorizados de Cleveland Range, LLC quienes cuentan con la experiencia y la capacitación así como el buen conocimiento de las medidas de seguridad y de los equipos que mantienen.

Cleveland Range, LLC, declina toda responsabilidad en caso de cualquier fallecimiento, lesiones, daños al equipo o daños a la propiedad resultantes de la utilización, del uso indebido o de la falta de utilización de la información provista en este documento.

Cleveland Range, LLC se ha esforzado en suministrar información precisa en este documento, pero no puede garantizar que este documento esté exento de errores y de omisiones no intencionales.

La información contenida en este documento podría estar sujeta a cambios técnicos o tecnológicos, revisiones o actualizaciones. Cleveland Range, LLC declina toda obligación o responsabilidad con respecto a erratas, modificaciones, revisiones o actualizaciones.

Los Representantes de Servicio calificados y autorizados de Cleveland Range, LLC tienen la obligación de seguir los procedimientos estándar de seguridad de la industria; los cuales incluyen pero no se limitan a los reglamentos de la OSHA (La Administración de la Seguridad y Salud Ocupacionales), los procedimientos de desconexión, cierre y etiquetado relativos a todos los servicios públicos incluyendo el suministro de vapor y los procedimientos de desconexión, cierre y etiquetado para los equipos y/o aparatos que funcionan a base de gas, electricidad o vapor.

Cuando se esté dando servicio o mantenimiento a un aparato de Cleveland Range, todos los servicios públicos (gas, electricidad, agua y vapor) deben estar APAGADOS para el equipo en cuestión y se debe seguir el procedimiento de cierre de operaciones de acuerdo con las prácticas aprobadas por la OSHA.

Los Representantes de Servicio calificados y autorizados de Cleveland Range, LLC tienen la obligación de actualizar constantemente sus conocimientos, destrezas, materiales y equipamiento.

FOR YOUR SAFETY / POUR VOTRE SÉCURITÉ / PARA SU SEGURIDAD

FOR YOUR SAFETY

Do not store or use gasoline or any other flammable liquids and vapours in the vicinity of this or any other appliance.

POUR VOTRE SÉCURITÉ

Ne pas entreposer ou utiliser d'essence ou d'autres liquides ou vapeurs inflammables à proximité de cet appareil ou de tout autre appareil.

PARA SU SEGURIDAD

No guarde ni use gasolina o cualesquiera otros líquidos o vapores inflamables en las cercanías de éste o cualquier otro aparato.

WARNING: Improper installation, operation, adjustment, alteration, service or maintenance can cause property damage, injury or death. Read the installation and operating instructions thoroughly before installing, operating or servicing this equipment.

AVERTISSEMENT : Toute mauvaise pratique en matière d'installation, de fonctionnement, de réglage, de modification, d'entretien ou de maintenance peut causer des dommages matériels, des blessures ou la mort. Lisez la totalité des instructions d'installation et d'utilisation avant d'installer, d'utiliser ou d'entretenir cet équipement.

ADVERTENCIA: La indebida instalación, operación, ajuste, modificación, servicio o mantenimiento puede ocasionar daños a la propiedad, lesiones o muerte. Lea detenidamente las instrucciones de instalación y de operación antes de instalar, poner a funcionar o dar servicio a este equipo.

Do not spray aerosols in the vicinity of this appliance while it is in operation.

Ne pas pulvériser des aérosols dans le voisinage de cet appareil alors qu'il est en fonctionnement.

No pulverice aerosoles en las proximidades de este aparato mientras está en funcionamiento.

This appliance is not to be used by persons with reduced physical, sensory or mental capabilities, or lack of experience and knowledge, unless they have been given supervision or instruction concerning use of the appliance by a person responsible for their safety.

Cet appareil ne doit pas être utilisé par des personnes dont les capacités physiques, sensorielles ou mentales sont réduites, ou des personnes dénuées d'expérience ou de connaissance, sauf si elles ont pu bénéficier, par l'intermédiaire d'une personne responsable de leur sécurité, d'une surveillance ou d'instructions préalables concernant l'utilisation de l'appareil.

Este aparato no debe ser utilizado por personas con capacidades físicas, sensoriales o mentales reducidas, o que no tengan la experiencia y los conocimientos adecuados, a menos que estas personas hayan recibido supervisión e instrucciones en cuanto al uso del aparato por la persona responsable de la seguridad de ellas.

This appliance is not for use by children and they must be supervised not to play with it.

Cet appareil n'est pas destiné à être utilisé par des enfants et ils doivent être surveillés pour s'assurer qu'ils ne jouent pas avec l'appareil.

Este aparato no debe ser usado por los niños y ellos deben ser supervisados para que no jueguen con el aparato.

Post in a prominent location, instructions to be followed in the event the user smells gas. This information shall be obtained by consulting your local gas supplier.

Affichez à un endroit bien visible les instructions à suivre dans le cas où l'utilisateur sent une odeur de gaz. Ces informations seront obtenues auprès de votre fournisseur de gaz local.

No obstruya el flujo del aire combustión y de ventilación.

Do not obstruct the flow of combustion and ventilation air.

Ne pas obstruer le flux d'air de combustion et de ventilation.

Guarde este manual para su referencia.

Retain this manual for your reference.

Conservez ce manuel pour votre référence.



WARNING / AVERTISSEMENT / ADVERTENCIA



Improper installation, operation, adjustment, alteration, service or maintenance can cause property damage, injury or death. Read the installation and operating instructions thoroughly before installing, operating or servicing this equipment. / Toute mauvaise pratique en matière d'installation, de fonctionnement, de réglage, de modification, d'entretien ou de maintenance peut causer des dommages matériels, des blessures ou la mort. Lisez la totalité des instructions d'installation et d'utilisation avant d'installer, d'utiliser ou d'entretenir cet équipement. / La indebida instalación, operación, ajuste, modificación, servicio o mantenimiento puede ocasionar daños a la propiedad, lesiones o muerte. Lea detenidamente las instrucciones de instalación y de operación antes de instalar, poner a funcionar o dar servicio a este equipo.



Do not lean on or place objects on lip. / Ne vous penchez pas sur ou ne placez pas des objets sur la lèvres. / No se apoye ni coloque objetos en el labio.



Hot product and surfaces. / Produit et surfaces chaudes. / Producto y superficies calientes.

Do not touch. / Ne pas toucher. / No la toque



Stand clear of product discharge path when discharging hot product. / Écartez-vous du chemin de décharge d'un produit chaud. / Permanezca alejado de la ruta de descarga del producto al vaciar producto caliente.



Keep hands away from moving parts and pinch points. / Gardez les mains loin des pièces mobiles et des points de pincement. / Mantenga las manos lejos de piezas móviles y puntos de presión muy localizada.



Do not fill kettle above recommended level marked on outside of kettle. / Ne remplissez pas la chaudière en excès du niveau recommandé marqué sur la chaudière. / No llene la marmita arriba del nivel recomendado marcado fuera de la marmita.



Unit must be anchored as per manual. / Unité doit être ancrée selon les directives du manuel. / Unidad debe estar fijado según el manual.



Keep appliance and area free and clear of combustibles. / Gardez l'appareil et son entourage libre de tous combustibles. / Mantenga el aparato y el área libres de combustibles.



Do not attempt to operate this appliance during a power failure. / N'essayez pas de faire fonctionner cet appareil lors d'une panne de courant. / No intente poner en marcha este aparato durante un fallo de suministro eléctrico.



Inspect unit daily for proper operation. / Inspectez l'unité tous les jours pour son bon fonctionnement. / Inspeccione diariamente el funcionamiento correcto de la unidad.



Heavy / Lour / Pesado

Team or mechanical lift. / Équipe ou remontée mécanique. / Equipo o elevador mecánico.



Surfaces and product may be hot! Wear protective equipment. / Les surfaces et le produit peuvent être chauds! Portez un équipement de protection. / ¡Las superficies y el producto pueden estar calientes! Utilice equipo protector.



Floor may become slippery from product spillage. / Déversement de produit peut causer de plancher à être glissant. / Derrame de producto puede causar piso a ser resbaladizo.



Unit exhaust contains carbon monoxide. Operate only under a properly functioning hood with adequate makeup air. / L'échappement de l'unité émet du monoxyde de carbone. Exploiter uniquement sous une hotte fonctionnant correctement avec une source adéquate d'air d'appoint. / El escape de la unidad contiene monóxido de carbono. Operar solamente bajo una campana en buen funcionamiento con aire de relleno adecuado.



Pressurized device. / Appareil sous pression. / Dispositivo de presión.

Keep clear of pressure relief discharge. / Restez à l'écart de la soupape de sureté. / Permanezca alejado de la descarga de presión.



Do not climb, sit or stand on equipment. / Il ne faut pas monter, s'asseoir ni se tenir debout sur l'équipement. / No subirse, ni sentarse ni pararse sobre el equipo.



Do not remove guards or operate without them. / Ne pas supprimer les gardes ou fonctionner sans eux. / No retire los guardias ni funcionar sin ellos.

SERVICING / ENTRETIEN / SERVICIO



Shut gas supply off prior to servicing. / Fourniture de gaz fermée au loin avant d'entretenir. / Suministro de gas cerrado apagado antes del mantenimiento.



Remove electrical power prior to servicing. / Coupez l'alimentation électrique avant l'entretien. / Desconecte la energía eléctrica antes de darle servicio.

Risk of electric shock. / Risque de choc électrique. / Riesgo de choque eléctrico.



Ensure kettle is at room temperature and pressure gauge is showing zero or less prior to removing any fittings. / Assurez-vous que la chaudière est à température ambiante et que le manomètre est à zéro ou moins avant de retirer des accessoires. / Asegúrese de que la marmita esté a temperatura ambiente y el manómetro esté mostrando cero o menos antes de retirar cualquier accesorio.



Have a qualified service technician maintain your equipment. / Demandez à un technicien en entretien et en réparation qualifié d'effectuer l'entretien de votre équipement. / Haga que un técnico de servicio calificado mantenga su equipo

INSTALLATION

GENERAL

Operating Conditions	Acceptable Range
Ambient Air Temperature	15-40 degrees Celsius
Relative Humidity	0-80%
Altitude	0-2000 meters
Voltage	208-240,480,3ph,60Hz
Location	Inside building, under ventilation hood

Ensure gas and electrical supplies match rating plate.

Installation of the kettle must be accomplished by qualified personnel working to all applicable local and national codes.

This equipment is built to comply with applicable standards for manufacturers. Included among those approval agencies are: UL, NSF, ASME/N.Bd., CSA, ETL, and others. Many local codes exist, and it is the responsibility of the owner/installer to comply with these codes.

Observe all clearance requirements. Do not obstruct the flow of combustion and ventilation air.

RECEIVING INSPECTION

Before unpacking visually inspect the unit for evidence of damage during shipping.

If damage is noticed, do not unpack the unit, follow shipping damage instructions.

SHIPPING DAMAGE INSTRUCTIONS

If shipping damage to the unit is discovered or suspected, observe the following guidelines in preparing a shipping damage claim.

1. As soon as damage is discovered or suspected, notify the carrier that delivered the shipment.
2. Write down a description of the damage or the reason for suspecting damage as soon as it is discovered. This will help in filling out the claim forms later.
3. Arrange for the carrier's representative to examine the damage.
4. Fill out all carrier claims forms and have the examining carrier sign and date each form.

APPROXIMATE WEIGHTS

Model #	Unit	Unit with shipping box	HAMKGL80T	1,325 lbs.	1,365 lbs.
HAMKGL40T	1,010 lbs.	1,050 lbs.	HAMKGL40	940 lbs.	980 lbs.
HAMKGL60T	1,120 lbs.	1,160 lbs.	HAMKGL60	1,030 lbs.	1,070 lbs.
			HAMKGL80	1,110 lbs.	1,150 lbs.

UNCRATING

Caution:

Straps under tension and will snap when cut.

Carton may contain staples and Skid contains Nails.

Use proper safety equipment and precautions.

Unit is heavy use adequate help or lifting equipment as needed.

1. Carefully cut any straps from container.
2. Lift off carton.
3. Inspect for hidden damage. If found refer to "SHIPPING DAMAGE INSTRUCTIONS".
4. Cut strap holding unit.



5. Remove lag bolts from feet.
6. Remove manual from kettle pot. Write down the model# and serial# of the unit onto the front of this manual.
7. Lift kettle off skid and move kettle to its installation location.
8. Discard packaging material according to local and or state requirements.



VENTILATION

Gas fired kettles are only to be installed under a ventilation hood in a room which has provisions for adequate make up air. Further information can be obtained by referring to the U.S.A. National Fire Protection Associations NFPA96 regulations. These standards have also been adopted by the National Building Code in Canada.

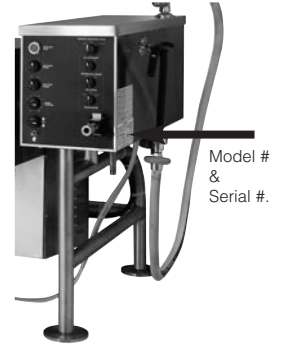

POSITIONING

This unit must be installed in accordance with the clearances shown on the rating label which is adhered to the unit.



1. When removing the kettle from the platform, handle with care to prevent scratching or any other damage. It is imperative that the kettle be level before bolting to the floor. This will prevent any twist or out of roundness to the kettle and will stop deflection of the agitator. Make sure the kettle is securely bolted to the floor and follow the procedure listed below:
 - ⇒ Position the kettle in its permanent location, check clearances and level the kettle by turning the adjustable feet.
 - ⇒ Lower the flange or flanges under the motor channel. Over adjustment, whether up or down, could cause misalignment and cause damage to the agitator drive shaft and hub (stationary kettles only).
2. Once positioned and leveled, permanently secure the kettle's flanged feet to the floor using 1/2 x 2 1/2 inch lag bolts and floor anchors (supplied by the installer). Two bolts per leg are required to secure each of the flanged feet.

COMPRESSED AIR CONNECTION

Mixer Kettles with an air activated discharge valve require a minimum of 90 PSI to operate correctly.

If the unit is also supplying air to a Metering Filling Station then a pressure of 100 PSI at a minimum volume of 25 CFM is required.

The air supplied to the mixer should be clean and dry. No oil should be added to the supply air. We recommend the compressed air system be equipped with a drier, filter, and automatic water dump on the air compressor receiver tank. If the distance between the tank and the unit is less than 100 feet then a minimum line size of 3/4" is required. A distance of 100 to 300 feet requires a minimum 1" line.

GAS

ENSURE THE GAS SUPPLY MATCHES THE KETTLE'S REQUIREMENTS AS STATED ON THE RATING PLATE.

Installation must conform, with local codes or in the absence of local codes, with the National Fuel Gas Code ANSI Z223.1/NFPA 54, or the Natural Gas and Propane Installation Code, CSA B149.1.

The appliance must be isolated from the gas supply piping system by closing its individual manual shut-off valve during any pressure testing of the gas supply piping system at test pressures equal to or less than 1/2 psi (3.45 kPa).

It is recommended that a sediment trap (drip leg) be installed in the gas supply line. If the gas pressure exceeds 1/2 psi (3.45 kPa) water column, a pressure regulator must be installed, to provide a maximum of 1/2 psi (3.45 kPa) water column gas pressure to the gas control valve.

Use a gas pipe joint compound which is resistant to L.P. gas. Test all pipe joints for leaks.

ELECTRICAL

ENSURE THE ELECTRICAL SUPPLY MATCHES THE KETTLE'S REQUIREMENTS AS STATED ON THE RATING LABEL.

Electrical installation must be in accordance with local codes and/or the National Electric Code ANSI/NFPA 70-1990 (USA) or the Canadian Electrical Code CSA Standard C22.1 (Canada). The kettle must be electrically grounded by the installer.

A separate fused disconnect switch must be supplied and installed in the high voltage electrical supply line.

A wiring diagram is affixed to the top of component box cover. Remove the right side panel to access component box. Feed the wiring through the cut-out in the bottom of the console using liquid tight conduit.

For proper electrical connections of units with remote controls please refer to the wiring diagram included with the unit. For tilting units wiring package is attached under the gearbox cover. For stationary units it is inside the Inverter housing on the left side of the kettle. For units with Remote consoles it is inside the console box.

WATER

The sealed jacket of the gas-fired kettle is precharged with the correct amount of a water-based formula, and therefore, no water connection is required to the kettle jacket. The kettle can be equipped with optional hot and cold water taps, requiring 1/2" copper tubing as supply lines.

INSTALLATION & OPERATION CHECKS

Although the kettle has been thoroughly tested before leaving the factory, the installer is responsible for ensuring the proper operation of kettle once installed.

- Before turning the kettle on, read the vacuum/pressure gauge. The gauge's needle should be in the green zone. If the needle is in the "VENT AIR" zone, follow Kettle Venting Instructions.
- Unit has been thoroughly checked for gas leaks at the factory however the installer should check all connections for any leaks which may have resulted from shipping or installation.
- Supply power to the kettle by placing the fused disconnect switch to the "ON" position.
- Open gas shut-off valve to turn on main gas supply.
- Turn the temperature control knob to "1" (Min.). The green LED light should remain lit, indicating the burner is lit, until the set temperature is reached. Then the green light will cycle on and off, indicating the burner is cycling on and off to maintain temperature.
- Tilt the kettle forward. After a few seconds the red "LOW WATER" light should be lit when the kettle is in a tilted position. This light

indicates that the burner has automatically been shut off by the kettle's safety circuit. This is a normal condition when the kettle is in a tilted position.

- Raise the kettle to the upright position. The red "LOW WATER" light should go out when the kettle is upright.
- Turn the temperature control knob to "10" (Max.) and allow the kettle to preheat. The green light should remain on until the set temperature is reached. Then the green light will cycle ON and OFF, indicating the burner is cycling ON and OFF to maintain temperature.
- Check carbon monoxide is less than 0.08 percent in an air-free sample of the flue gases. See FREE AIR CALCULATION procedure in "Maintenance Procedures & Parts Lists" manual.
- After installation the kettle must be thoroughly cleaned and sanitized prior to cooking.

KETTLE VENTING INSTRUCTIONS

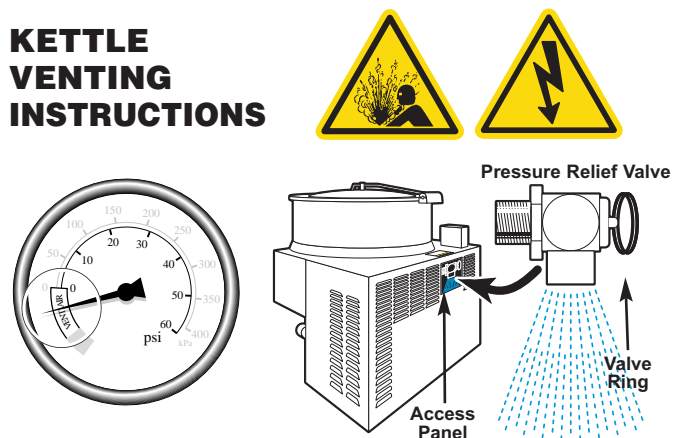

The following venting procedure should be followed when the Vacuum/Pressure Gauge needle is in the "VENT AIR" zone:

NOTE: Check for and eliminate leaks prior to venting (see REPAIRING LEAKS IN STEAM JACKETED KETTLE FITTINGS).

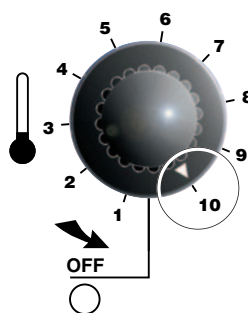

- Remove Access Panel from back of main kettle console.
- Turn kettle ON and set temperature control to **10**, heat the empty kettle until unit cycles off.
- Vent kettle by pulling Valve Ring eight to fifteen times, holding valve open for two seconds each time.

NOTE: If unit cycles ON, stop venting and wait for kettle to cycle OFF before continuing.

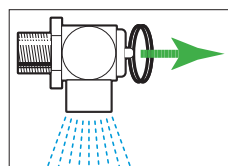

- Turn kettle OFF. Add cold water to kettle until its surface temperature is below 100°F. The pressure gauge needle should be in the green zone, indicating a vacuum in the kettle's jacket.

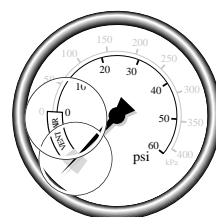

- If needle is in the green zone then venting was successful. If not repeat procedure.

WARNING

If for any reason this unit is not functioning correctly DO NOT OPERATE. Contact your authorized service agent.

OPERATING INSTRUCTIONS



OPERATING CONTROLS AND INDICATORS

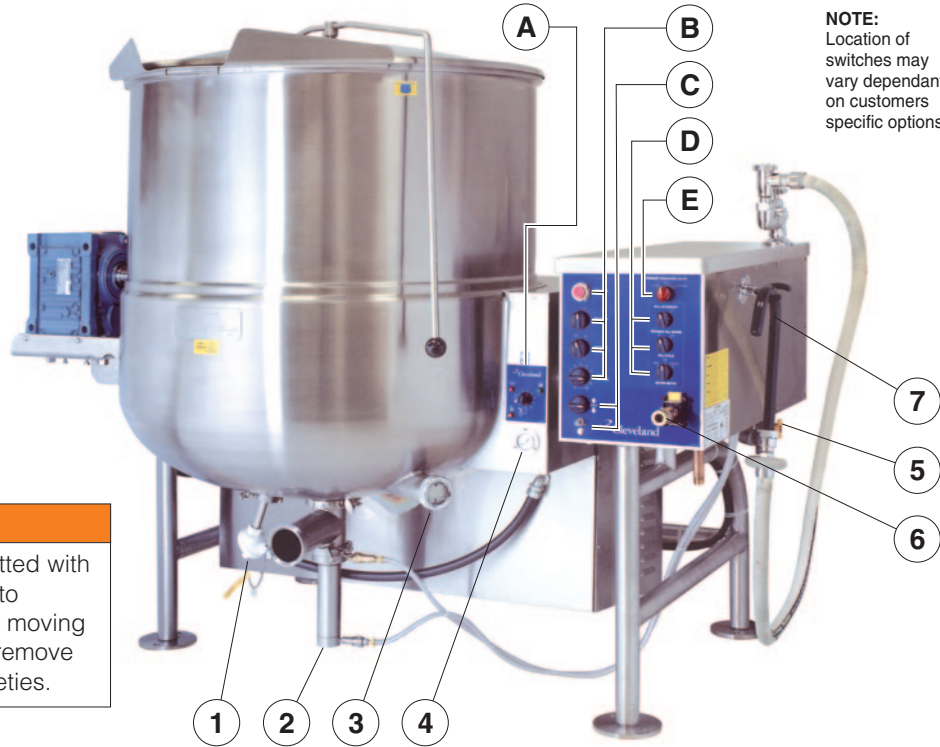

NOTE:
Location of switches may vary dependant on customers specific options

WARNING:



This unit has been fitted with a cover and screen to prevent contact with moving mixer arms. Do not remove or bypass these safeties.

- A**
- Green Heat Indicator Light** - When lit, indicates gas burner is on; cycles on-off with solid state controls.
 - Red Low Water Indicator Light** - When lit, in the upright position, indicates kettle gas burner has cut out and unit requires more water. Occasional pulsing of this light is normal.
 - Orange Off Indicator Light**
 - Solid State Temperature Control Knob / On-Off Toggle Switch** - Controls electrical power to kettle, and allows operator to select kettle heat increments from minimum, 1-10. A setting of 7 or higher will boil water.

- B**
- Agitator Stop Button**
Stops agitator in case of emergency
 - Agitator Start Switch**
Starts agitator. Agitator power control switch must be ON
 - Agitator Power Switch**
Allows power to agitator. When not in use, turn control power OFF
 - Agitator Speed Control Switch**
Turn clockwise until desired speed is reached

- C**
- Power tilt control switch**
Tilts kettle for pouring; some kettles have manual hand tilt
 - Reset circuit breaker**
Protects power tilt system from overload. Push to reset



Water Meter Digital Counter (not shown)
Location may vary dependant on customer's specific options

- D**
- Fill Interrupt Switch**
Interrupts water fill cycle
 - Potable Fill Water Switch**
Selects hot or cold water
 - Fill Cycle Switch**
Start/continue cycle switch
- E**
- Product Discharge Valve Switch**
Toggle momentary switch to desired valve opening

- 1 Temperature Sensor**
Senses temperature of product
- 2 Automatic Dump Valve**
Empties kettle of either food product or wash water
- 3 Sight Glass**
For checking water level of kettle jacket
- 4 Vacuum /Pressure Gauge**
Indicates steam pressure inside steam jacket in PSI, as well as vacuum in inches of mercury
- 5 Gas Shut-Off Valve**
- 6 Air Quick Connect**
Push yellow tab down to release air pressure before disconnecting air hose
- 7 Kettle Filler Nozzle**

OPERATING THE KETTLE



Intended Use:

Processing of food and pharmaceuticals in non-residential locations. Not for the making of dough or other heavy dough like products.

Intended Users:

- Supervised and trained staff during production periods.
- Trained maintenance and service personnel.

Removable component weights

Lbs (kg)	60 gal	80 gal	100 gal
Primary arm with blades	51 (9.5)	65 (10.4)	70 (32)
Screen	7 (3.2)	8 (3.6)	9 (4.1)
Air valve complete			12 (5.4)
Air cylinder only			8 (3.6)
Air valve body only			4 (1.8)

Noise level

Noise level maximum 80 Decibels.

Mixing Arm Rotation speeds

Arm	Speed (RPM)
Primary	0-40
Secondary	0-210

Rim (loading) heights

Rim heights are given below. It is up to owners of the equipment to ensure the operators are performing the loading in a safe and acceptable manner.

Size	Height
60 gal.	48"
80 gal.	52"
100 gal.	54"

Emergency

In the event of a fire or other emergency.

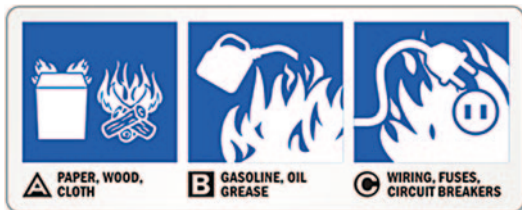

Turn off unit

Shut off power supplies including Electrical, Gas or Steam as applicable. (If safe to do so.)

Using fire extinguishers is only recommended if you are trained and feel safe to do so. Use only Fire extinguishers rated ABC.

This is a pressure vessel and with a properly operating safety valve will not exceed rated pressures. Jacket contains water and trace amounts of rust inhibitor and/or antifreeze.

1. Perform daily startup inspection.

Temperature Control Setting	Approximate Product Temperature	
	°F	°C
1.	120	49
2.	135	57
3.	150	66
4.	165	74
5.	180	82
6.	195	91
7.	210	99
8.	225	107
9.	245	118
10.	265	130

NOTE: Certain combinations of ingredients will result in temperature variations

2. Preheat the kettle by turning the ON/OFF Temperature Control to the desired temperature setting. The Heat Indicator Light (Green) will remain lit, indicating the burner is on, until the temperature setting is reached. When the green light goes off, the burners are off, and preheating is complete.

NOTE: When cooking egg and milk products, the kettle should not be preheated, as products of this nature adhere to hot cooking surfaces.

3. Place food product into the kettle. The green Heat Indicator Light will cycle on and off indicating the burners are cycling on and off to maintain the set temperature.



4. When cooking is completed turn Temperature Control to the "OFF" position.
5. Pour the contents of the kettle into an appropriate container by tilting the kettle forward or using discharge valve.



NOTE: Cleaning should be performed immediately after cooked foods are removed.

NOTE: A five minute complete shut-of period is required before relighting.

⚠ WARNING

If for any reason this unit is not functioning correctly DO NOT OPERATE. Contact your authorized service agent.

Heating Instructions

Manual Heating

1. Turn temperature control knob clockwise to turn on the kettle, Green light will come on.
2. Turn temperature control knob to desired setting. (1-10)

If Red light is on, it indicates that the water level is low in the jacket.

With DTCI or TCR-DTCI Option

1. Turn Controller switch to “OFF” if Manual heating is desired.
See picture #2.
2. Follow instructions for **Manual Heating**.

Heating with DTCI option

1. Turn Controller switch to “ON”. See pictures #2.
2. Turn temperature control knob on the kettle to “10”. See picture #1.
3. DTCI will go through self-check sequence.
Note; ZERO flashes on left indicates no sensor selected. Buttons only adjust flashing digits.
4. Press “*” to display set point.
5. Press and hold “*” then press ▲ to increase or press ▼ to decrease the set point.
The Controller is operational with factory settings.

Heating with TCR-DTCI option

1. Turn Controller switch to “ON”.
See pictures #2.
2. Turn temperature control knob on the kettle to “10”.
See picture #1.
3. Push function key “↻” until “OFF” is displayed.
4. Push and hold key “↑” or “↓” until desired temperature is set.
5. To start; push function key “↻” until “Ctrl” is displayed.
6. Push “↓” key to start operation.
7. To stop; push function key “↻” until “OFF” is displayed.
8. Push “↓” key to stop operation.



Picture #1



Picture #2



Picture #3

Water Meter Option

1. Switch to “**Hot**” or “**Cold**” water.
2. Push “▶” key until the digit you want to change is flashing in the lower display window. Then use the “▼” key to change the value of the flashing digit.
3. When all digits are selected (lower display window) for the required quantity of water press the “**ENT**” key.
4. Push “**RST**” button to start at “**0**”.
5. To start filling kettle, turn “**START**” switch to “**Continue**”.
6. Delivery will start at “**0**” (upper display window) and stop at the preset volume.
7. To interrupt delivery anytime, turn “**INTERRUPT**” switch to right.
8. To complete delivery after interruption, again turn “**START**” switch to “**Continue**”.
9. Turning “**START**” switch to “**RESET**” will again start the delivery from “**0**”.



Mixing ("AGITATOR ")

WARNING:

- Never add product to kettle while agitator is running.
- Do not put hands in kettle.
- Watch for loose clothing near agitator.

1. Turn "**SPEED CONTROL**" to "**0**".
2. Switch agitator to "**ON**".
3. Push agitator "**START**" to initiate mixing.
4. Turn "**SPEED CONTROL**" to desired mixing speed.
5. To stop mixing action, push agitator **stop** button.

NOTE: Mixing speed depends on the product consistency. The faster the mixing speed the more damage may be done to fragile product.

Emptying the Kettle

1. To open automatic dump valve:
 - Turn PRODUCT DISCHARGE VALVE switch clockwise to JOG TO OPEN. Release switch to the HOLD position when desired valve opening is achieved.
 - To close valve, turn switch counterclockwise to CLOSED position.

2. To avoid splashing, slowly empty kettle contents into an appropriate container by partially opening discharge valve.

NOTE: When pumping with a Metering Filling Station the speed of the agitator arm must be sufficient to suspend the heavier items in the mix in order to achieve an even distribution in your packaged items.

3. Immediately clean kettle as outlined in CLEANING INSTRUCTIONS on page.

CLEANING INSTRUCTIONS



CARE AND CLEANING

Cooking equipment must be cleaned regularly to maintain its fast, efficient cooking performance and to ensure its continued safe, reliable operation. The best time to clean is shortly after each use (allow unit to cool to a safe temperature).

WARNINGS



Chloride Cleaners

Do not use detergents or cleansers that are chloride based or contain quaternary salt.



Wire Brush & Scrapers

Do not use a metal bristle brush or scraper.



Steel Pads

Steel wool should never be used for cleaning the stainless steel.



High Pressure Spray Hose

Unit should never be cleaned with a high pressure spray hose.



Stagnant Water

Do not leave water sitting in unit when not in use.

CLEANING INSTRUCTIONS

1. Turn power off.
2. Remove drain screen (if applicable). Thoroughly wash and rinse the screen either in a sink or a dishwasher.
3. Prepare a warm water and mild detergent solution in the unit.
4. Remove food soil using a nylon brush.
5. Loosen food which is stuck by allowing it to soak at a low temperature setting.
6. Drain unit.
7. Rinse interior thoroughly.
8. If the unit is equipped with a **Butterfly Valve**, clean as follows:
 - a) Place valve in open position.
 - b) Wash using a warm water and mild detergent solution.
 - c) Remove food deposits using a nylon brush.
 - d) Rinse with fresh water.
 - e) Leave valve open when unit is not in use.
9. If the unit is equipped with an **Air Valve**, clean as follows:
 - a) Open product valve.
 - b) Disconnect air hoses.
 - c) Remove air cylinder.
 - d) Remove valve tee.
 - e) Remove all O-rings.
 - f) Clean air cylinder, do not submerge in water. Wipe clean and sanitize.
 - g) Clean and sanitize tee and O-rings.
 - h) Grease and reinstall O-rings.
 - i) Reinstall valve tee to kettle outlet.
 - j) Reinstall air cylinder to bottom of tee.
 - k) Reconnect air hoses.
 - l) Close valve and check for alignment.
10. Using mild soapy water and a damp sponge, wash the exterior, rinse, and dry.

NOTES

- ⇒ For more difficult cleaning applications one of the following can be used: alcohol, baking soda, vinegar, or a solution of ammonia in water.
- ⇒ Leave the cover off when the kettle is not in use.
- ⇒ For more detailed instructions refer to Stainless Steel Equipment Care and Cleaning (www.nafem.org/resources/stainlesssteelfinal.doc) on Nafem's website (www.nafem.org).

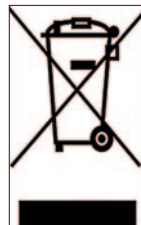

DISPOSAL INSTRUCTIONS



This unit is recyclable. Do not dispose in landfill.

The unit may contain rust inhibitor and or antifreeze within the jacket. Drain unit and dispose following Federal, State and local regulations.

The majority of the unit is composed of stainless steel. Other alloys and electrical components make up a small percentage of the total. Follow Federal, state and local regulations for disposal.

FLUSH PISTON VALVE

Daily - clean valve as follows:

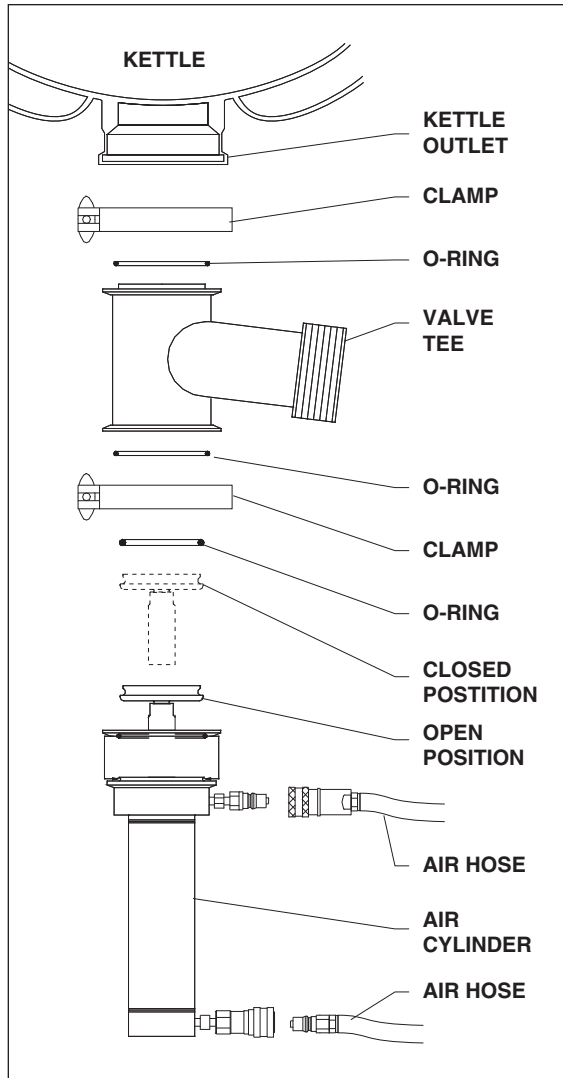

1. Open product valve.
2. Disconnect air hoses.
3. Remove air cylinder.
4. Remove valve tee.
5. Remove all O-rings.
6. Clean air cylinder, do not submerge in water. Wipe clean and sanitize.
7. Clean and sanitize tee and O-rings.
8. Grease and reinstall O-rings.
9. Reinstall tee to kettle outlet.
10. Reinstall air cylinder to bottom of tee.
11. Reconnect air hoses.
12. Close valve and check for alignment.

AGITATOR

To remove and clean agitator (two-person job):

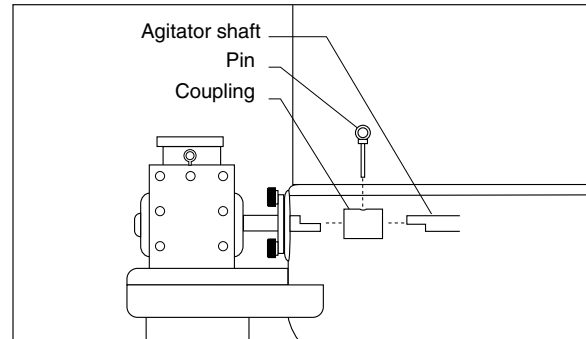

1. Remove scraper blades.
2. Rotate agitator until pull pin is on top side.
3. Turn power OFF.
4. Pull pin out.
5. Slide coupling toward kettle wall, and carefully lift agitator pulling back to lift out.
6. Clean in a sink, using a warm water and mild detergent solution.
7. Rinse with fresh water.

AGITATOR BUSHING

With agitator out, remove bushing by:

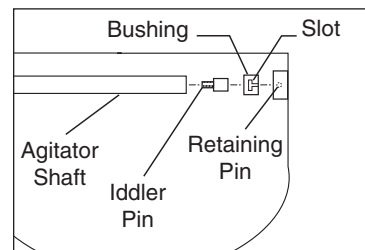

1. Remove bushing by turning 1/4 turn and pulling away from the kettle wall.
2. Clean, rinse and sanitize bushing and bushing mounting area.
3. Lubricate metal surfaces with food safe grease.
4. Install bushing by locating retaining pin and sliding bushing on.
5. Rotate to lock into position.

SCRAPER BLADES

To remove and clean scraper blades:

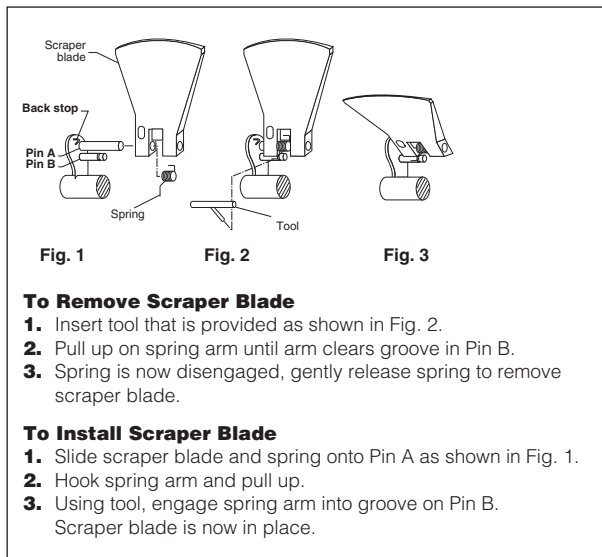

1. Remove scraper blades using the tool to release the spring from the retaining pin and sliding the blade off the shaft.
2. Place parts in a pan of warm water to soak.
3. Clean in a sink, using a warm water and mild detergent solution.
4. Rinse with fresh water.
5. Allow to dry thoroughly on a flat, clean surface.

SEAL RETAINER PLATE

(Replaces QUAD RING after June 1999.)

To clean seal retainer plate:

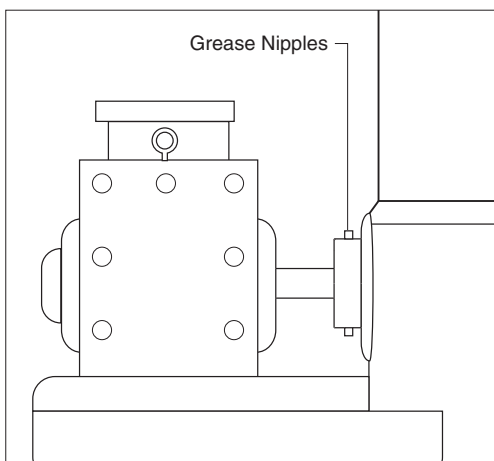

1. Apply food safe grease to grease nipples until you see clean grease inside the kettle. Grease daily.

PREVENTATIVE MAINTENANCE

FOR MAINTENANCE AND REPAIRS CONTACT YOUR AUTHORIZED MANITOWOC SERVICE AGENCY AND HAVE A QUALIFIED SERVICE TECHNICIAN MAINTAIN YOUR EQUIPMENT.



WARNING

If for any reason this unit is not functioning correctly DO NOT OPERATE. Contact your authorized service agent.

INSPECTION AND MAINTENANCE CHECKLIST

Cleveland Range equipment requires little preventative maintenance. We do however provide the following chart as a guide line for inspection and maintenance to keep your unit functioning at 100%.



DAILY PRE-STARTUP INSPECTION

1. Flue is not obstructed.
2. Pressure Gauge is in the green when unit is cold.
3. Green Light comes on when unit is energized.
4. Red Light comes on when unit is tilted (tilting models only).

MONTHLY INSPECTION

1. Inspect all switches for damage. Replace rubber boots or switches as required.
2. Check that product discharge valve works fully and smoothly.
3. Check that the 3 way regulator shuts off the incoming air and completely vacates the air from the air hose to the metering filling station.
4. Tilt kettle and check for smooth operation in both directions (tilting models).
5. Inspect mixer blades for cracks or other damage - replace as required. Refer to NEW SCRAPER BLADE INSTALLATION PROCEDURE.

SIX MONTH MAINTENANCE

1. Check spring assist covers for tightness to handle and ensure spring is holding cover up - adjust if required. Refer to HINGE ADJUSTMENT INSTRUCTIONS.
2. Check quad ring and replace if required. Refer to QUAD RING REPLACEMENT PROCEDURE.
3. Inspect oiler in gear box and fill with oil if required. Refer to OILER FILLING PROCEDURE.
4. Inspect air filter cartridge and replace if required. Refer to AIR FILTER REPLACEMENT PROCEDURE.

SIX MONTH SERVICE INSPECTION

1. Perform daily startup inspection.
2. Gasket around top cover is in good condition.
3. Tilt hand wheel is tight.
4. Grease bearings on both trunnions.
5. Check for play in gears (adjust if required).
6. Fasteners securing panels are in place and tight.
7. Perform pressure relief valve periodic test (see Pressure Relief Valve Testing).
8. Adequate exhaust and makeup air is supplied to working area.
9. Check spring assist covers for tightness to handle and ensure spring is holding cover up - adjust if required. Refer to HINGE ADJUSTMENT INSTRUCTIONS.
10. Check quad ring and replace if required. Refer to QUAD RING REPLACEMENT PROCEDURE.
11. Inspect oiler in gear box and fill with oil if required. Refer to OILER FILLING PROCEDURE.
12. Inspect air filter cartridge and replace if required. Refer to AIR FILTER REPLACEMENT PROCEDURE.

YEARLY SERVICE INSPECTION

1. Perform six month service inspection.
2. Check kettle maximum temperature setting (see Calibrating Procedure).
3. Inspect safety thermostat for proper connections (see Safety Thermostat).
4. Inspect Low water probe for proper connections (see Low Water Level Probe).
5. Inspect safety valve installation (see SAFETY VALVE INSTALLATION).
6. Clean blower.
7. Perform free air calculation (see FREE AIR CALCULATION).

TROUBLESHOOTING & MAINTENANCE PROCEDURES / DÉPANNAGE ET PROCÉDURES DE MAINTENANCE / PROCEDIMIENTOS DE SOLUCIÓN DE PROBLEMAS Y MANTENIMIENTO

*All trouble shooting guides and maintenance procedures are meant to be used by
Qualified Service Technician /*

*Tous les guides de dépannage et les procédures d'entretien sont destinés à être
utilisés par un technicien qualifié /*

*Todas las guías de solución de problemas y los procedimientos de mantenimiento
están diseñados para ser utilizados por un técnico calificado.*



Any repairs to the pressure vessel must be done by a certified pressure vessel repair shop and all repair methods and materials must be approved by the manufacturer.

Toute réparation du Navire à pression doit être effectuée par un atelier de réparation agréé et toutes les méthodes et matériaux de réparation doivent être approuvés par le fabricant.

Cualquier reparación del recipiente a presión debe ser efectuada por un taller de reparación certificado y todos los métodos y materiales de reparación deben ser aprobados por el fabricante.

TROUBLESHOOTING GUIDES

GENERAL

1. When the unit is turned on.
 - Power is sent to primary side of the 115vac/16vac transformer.
 - Power is sent to the normally closed high limit.
 - From the high limit power is sent to the normally open contacts of the 12VDC relay and the L1 and L2 terminals of the ignition module.
2. From the secondary of the transformer 16VAC is sent to the controller.
 - Power is sent to the red LED (low water indicator light) from terminal 4 of the controller.
 - If the water probe is grounded through water the LED will go off.
 - If the water probe is not grounded the LED will remain on and the unit will not heat.
 - If the resistance of the thermistor is higher than the setting of the potentiometer(the unit is calling for heat) then 16VDC is sent to the coil of the relay and the green LED (heat indicator light)
3. With the contacts of the relay closed, 115VAC is sent to the blower and primary coil of the 115VAC/24VAC transformer.
 - From the secondary of the 24VAC transformer power is sent to the normally open contacts of the air switch.
 - When the air from the blower closes the air switch, 24VAC is sent to the Th terminal of the ignition module.
4. With both 115VAC (at L1 and L2) and 24VAC (at Gnd and Th) to the ignition module then 115VAC will be sent to the surface igniter.
5. After the ignition module has been energized for 24 seconds the module will send 24VAC to the gas valve.
 - The gas will touch the hot igniter and ignite.
 - The kettle will build pressure until the controller is satisfied by the thermistor at the setting of the potentiometer.
 - The controller will then turn off the heat circuit until the temperature of the kettle is below the setting

OPERATING SEQUENCE - HEATING

STEP	ACTION	RESULT 1	RESULT 2
1.	Close main circuit breaker.	115 volts is supplied by primary contactor to kettle On/Off switch and tilt relay contacts. Power supplied to tilt assembly.	
2.	On/Off switch on kettle switched to ON.	115/16 volt transformer supplies power to control boxes.	Amber LED is illuminated. (Used prior to July 2004)
3.	Control box.	A/ Requires grounded probe to function (pin #5). B/ More than 6 volts at pin #2. Control box energizes 16 volt DC relay (pin #6).	a/ Green LED illuminates. b/ 16 VDC relay contacts close.
4.	16 VDC relay contacts close.	A/ Blower energizes. B/ 115/25 volt transformer energizes. C/ 115 volt supplied to ignition module.	a/ Air switch contacts close. a/ 25 volts supplied to ignition module.
5.	Ignition module.	Supplies 115 volts to ignition.	Within 20 seconds ignitor glows red.
6.	115 volts turned off to ignitor.	A/ Gas valve is energized. B/ Ignitor becomes sensor.	a/ Burner ignites. a/ If temperature drops in chamber gas valve is de-energized within five seconds. b/ Ignitor will try twice more to light before locking out.
7.	Temperature reached.	A/ Less than 6 volts at pin #2. Control box de-energizes 16 volt DC relay (pin #6)	a/ Green LED turns off. b/ 16 VDC relay contacts open. c/ Blower turns off. d/ 25 volt transformer de-energizes.

QUICK CHECKS: Potentiometer - Range 0 - 50K, Safety Thermostat - Normally Closed, Thermistor - Range 0 - 100K, Water Level Probe - Must be submerged in water for burners to work

OPERATING SEQUENCE - AGITATOR

1.	On/Off switch closed.	A/ Three phase contactor closes to supply power to variable speed drive.	a/ Indicator light is energized.
2.	Start button momentarily depressed.	A/ Power to agitator motor.	a/ Motor comes up to speed.
3.	Speed control turned up.	A/ Motor speed increases.	

OPERATING SEQUENCE - POWER TILT

1.	Turn and hold tilt switch in down position.	A/ Relay 2 is energized.	a/ Tilt motor is energized.
2.	Kettle tilts until limit switch is depressed.	A/ Power interrupted to down side of tilt switch.	a/ Relay de-energized. b/ Motor stops.
3.	Turn and hold tilt switch in up position.	A/ Relay 1 is energized.	a/ Tilt motor is energized.
4.	Kettle tilts until limit switch is depressed.	A/ Power interrupted to up side of tilt switch.	a/ Relay de-energized. b/ Motor stops.

TROUBLESHOOTING GUIDES (Legend)

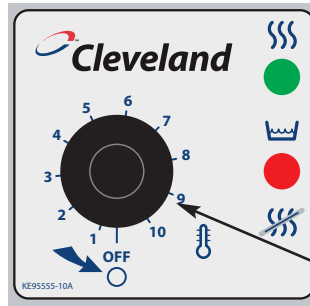
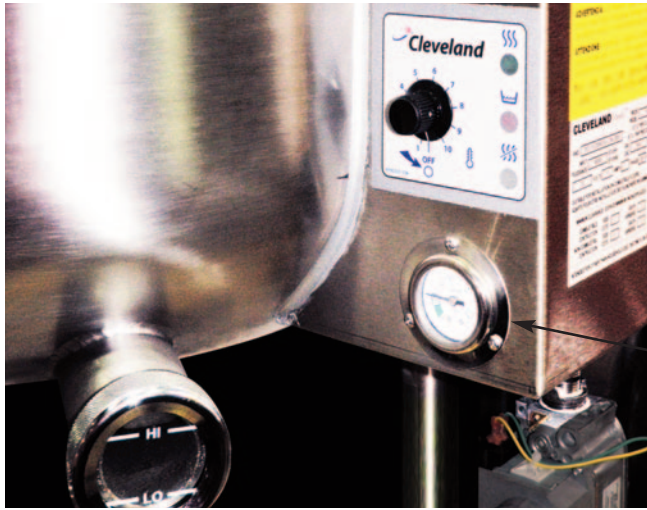

← 1. Green Light

← 2. Red Light

3. ON/OFF Switch
c/w Potentiometer

6. Pressure
Gauge

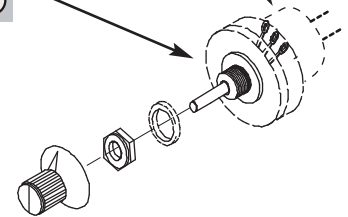

5. Kettle Jacket Water Sight Glass

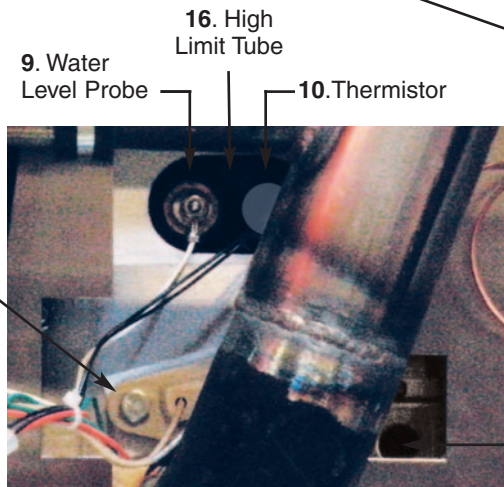

16. High
Limit Tube

9. Water
Level Probe

10. Thermistor

11. Ignitor



7. Gas Valve
(showing hose for
pressure tap)

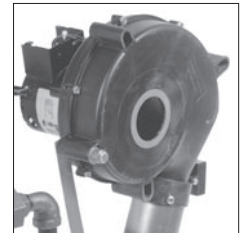

8. Blower

- 1. Green Light
- 2. Red Light
- 3. ON/OFF Switch
- 5. Kettle Jacket
Water Sight Glass
- 6. Pressure Gauge
- 7. Gas Valve
- 8. Blower
- 9. Water Level Probe
- 10. Thermistor
- 11. Ignitor
- 12. Sight Glass

12. Flame Sight Glass

15. SSK Controller



13. 14V
Transformer

14. 24V
Igniton
Transformer

- 13. 14V Transformer
- 14. 24V Igniton
Transformer
- 15. SSK Controller
- 16. High Limit
- 17. Ignition Module
- 18. Relay
- 19. Air Switch

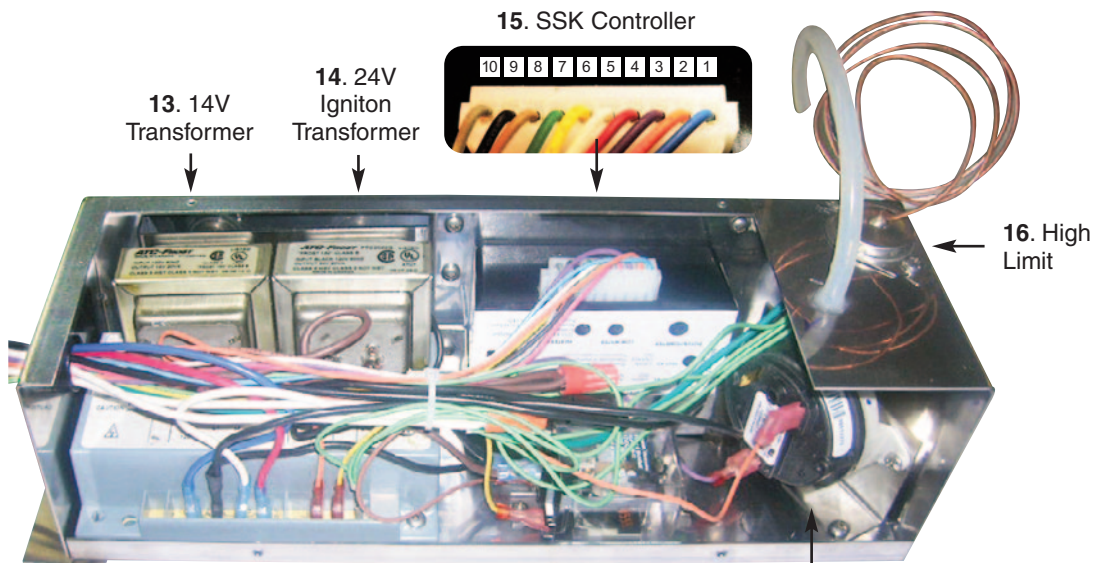

← 16. High
Limit

↑ 17. Ignition Module

↑ 18. Relay

↑ 19. Air Switch

TROUBLESHOOTING GUIDES (continued)

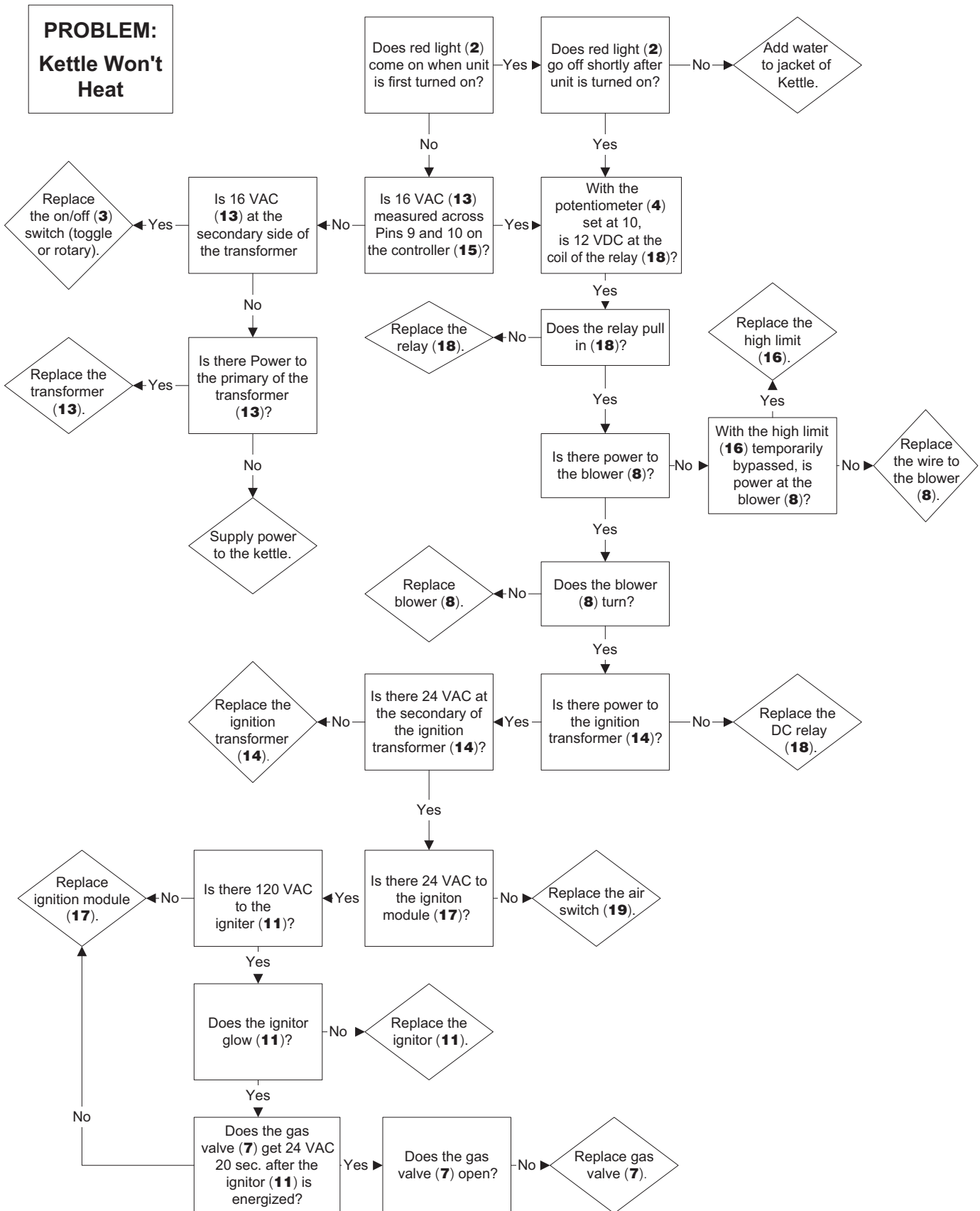

TROUBLESHOOTING GUIDES (continued)

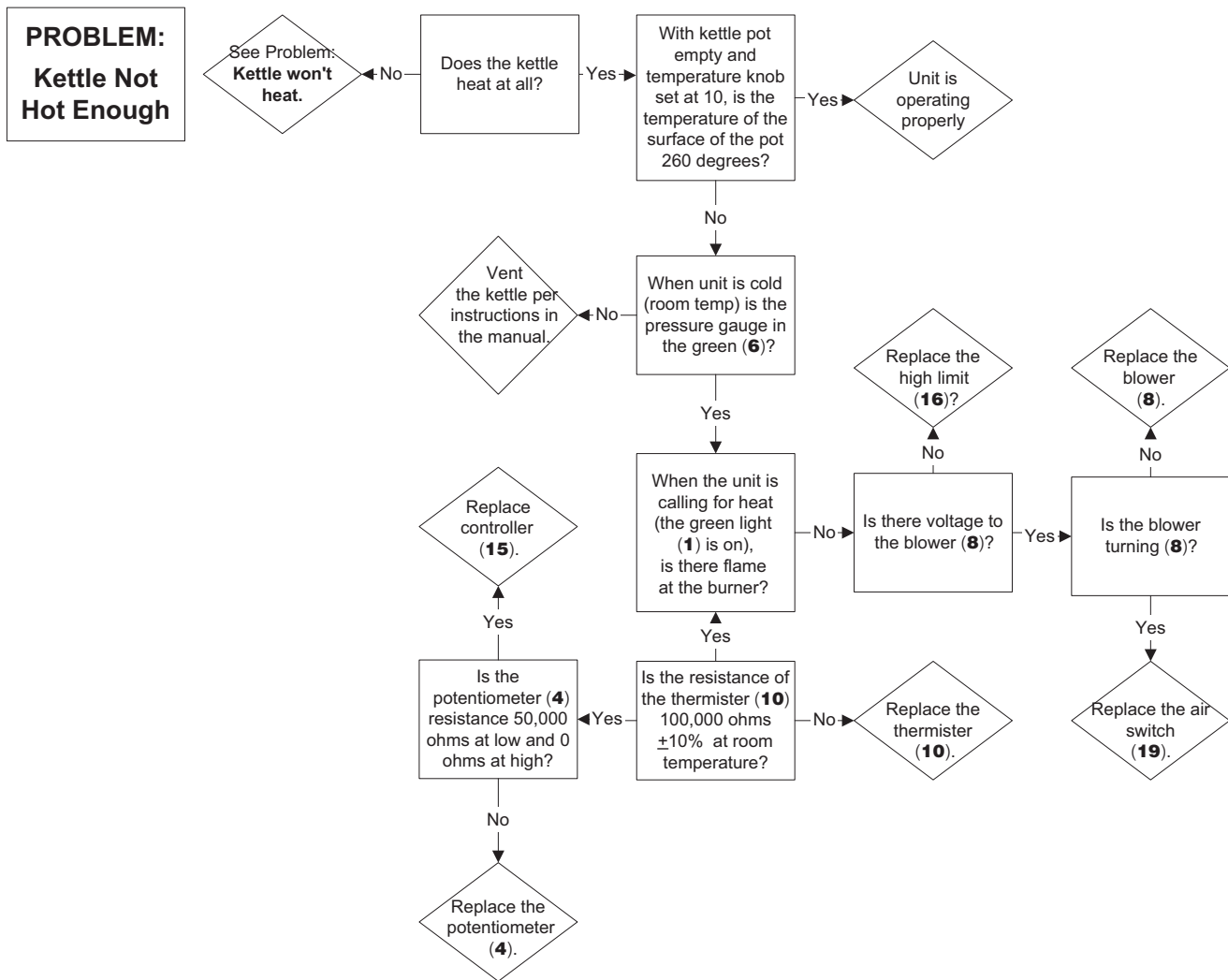

PROBLEM: Kettle Has Delayed Ignition

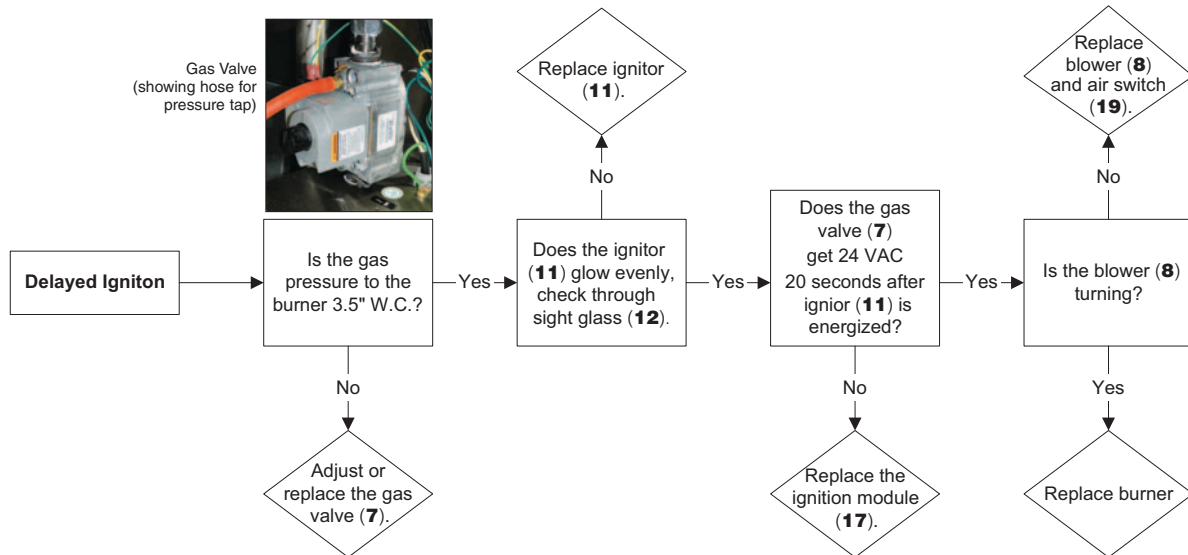

TROUBLESHOOTING GUIDES (continued)

PROBLEM:
Kettle
Gets Too
Hot

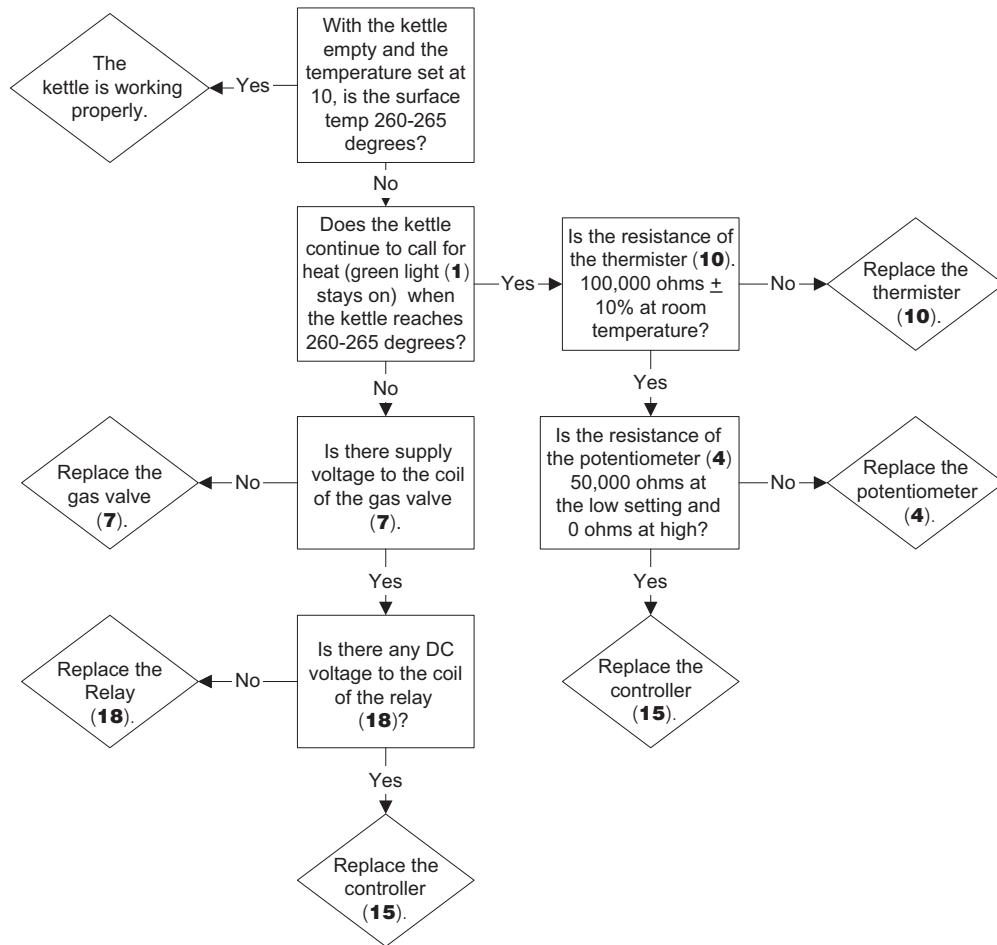

PROBLEM: Red LED Stays On

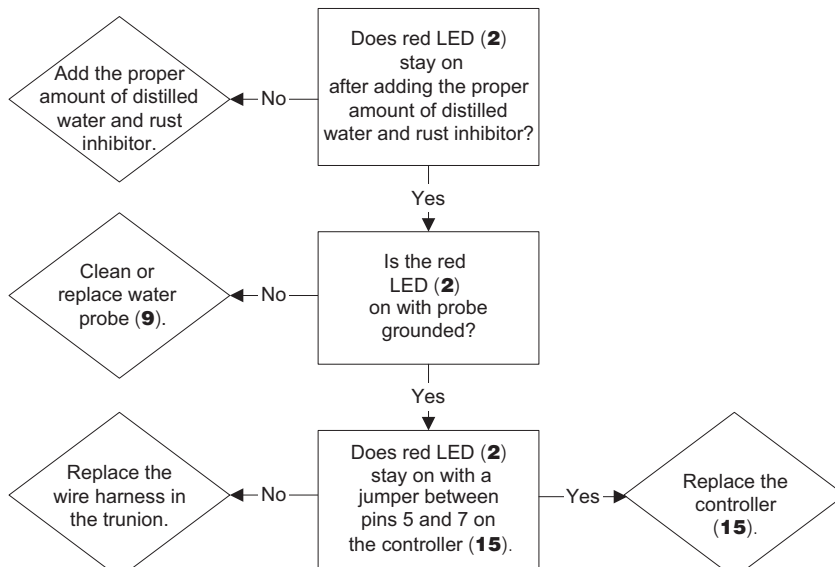

KETTLE SAFETY INSPECTION AND TESTING

SAFETY VALVE INSTALLATION:

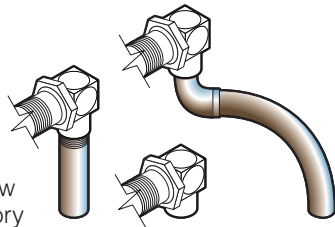

The above illustrations show the three variations of factory installed Safety Valves.

Modifications are unacceptable.

SAFETY THERMOSTAT:

Correct Installation

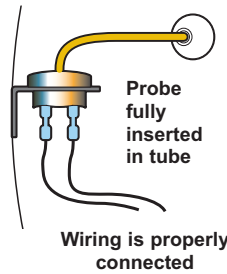

Incorrect Installations

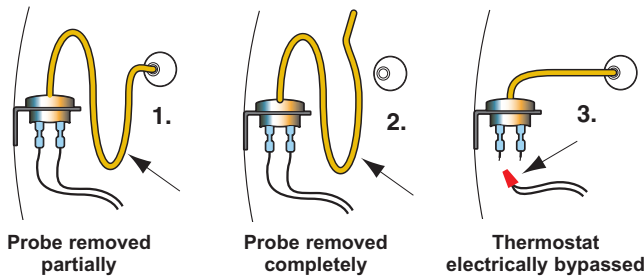

1. Safety thermostat probe is not completely inserted into tubing.
2. Safety thermostat probe is removed from tubing.
3. Safety thermostat electrical connection is bypassed.

OPERATING THERMOSTAT:

If maximum temperature is not in this range (on empty kettle), refer to the "Calibrating Procedure".

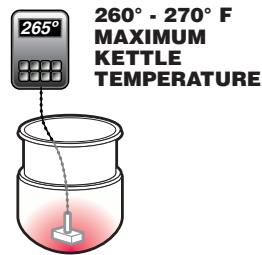

GAS KETTLE AIR SWITCH:

Correct

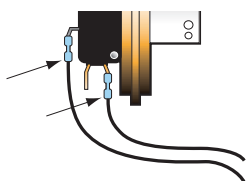

Wiring is properly connected

Incorrect

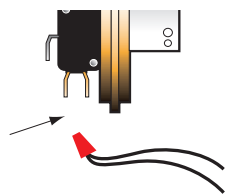

Switch electrically bypassed

LOW WATER LEVEL PROBE:

Probe properly attached ✓

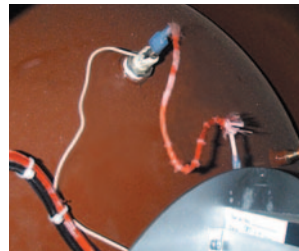
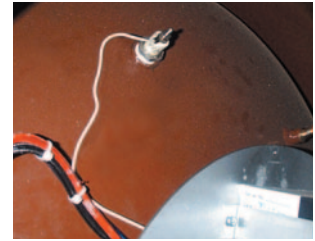

✗ Probe bypassed by running (A) an additional wire

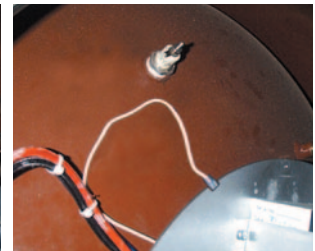

✗ Probe bypassed by (B) grounding the connecting wire

PRESSURE RELIEF VALVE TESTING

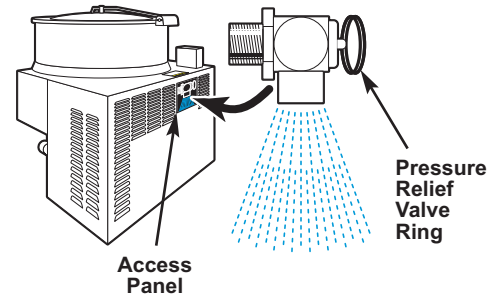

WARNING: Use of gloves and eye protection to prevent personal injury.

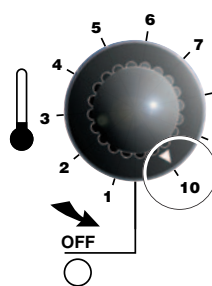

1. With the kettle empty, set On-Off Switch/Temperature Control to "10" (Max.). Allow the kettle to heat until the unit cycles off.
2. Switch On-Off Switch/Temperature Control to "0" (Off) and disconnect main power at fused disconnect switch.
3. Remove Access Panel at back of main kettle console.
4. Pull Pressure Relief Valve Ring open for a maximum of one second. Repeat test three to four times. Each time the mechanism should move freely and be accompanied by a rapid escape of steam.
5. Replace access panel.

IMPORTANT:

If valve appears to be sticking replace pressure relief valve.

If foreign material is discharged then drain kettle and replace pressure relief valve.

CALIBRATING PROCEDURE

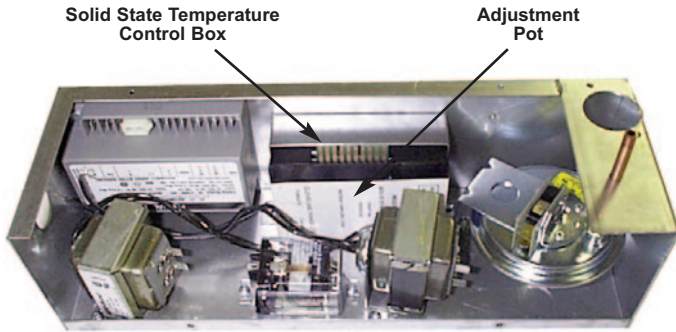

1. Ensure the unit has a vacuum before you begin calibrating procedures. If unit requires venting refer to KETTLE VENTING INSTRUCTIONS.
2. Set On-Off Switch/Temperature Control to "10" (Max.).
3. Allow the unit to cycle twice.
4. Check temperature of the inner kettle surface with a digital surface thermometer.
5. Temperature should be between 260°F and 265°F.

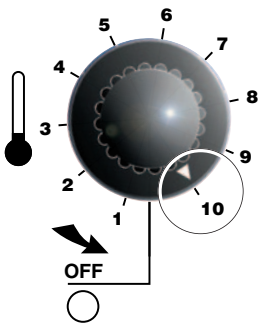

6. Using a screw driver adjust temperature by turning the potentiometer on the Solid State Temperature Control Box. Turn very little. Turn clockwise to INCREASES and counter-clockwise to DECREASE temperature.
7. Allow the unit to cycle twice.
8. Check temperature of the inner kettle surface with a digital surface thermometer.

9. Repeat steps 4. through 8. until unit is calibrated.

FREE AIR CALCULATION

Insert drager pump tube 4" down the center of the flue and take one sample each of Carbon Dioxide (CO₂) and Carbon Monoxide (CO) and record results.

_____ % CO
_____ % CO₂
(PPM)

With results obtained for CO₂ use chart to determine dilution factor for gas type used.

_____ Dilution Factor

Enter these numbers in the following formula to determine the concentration of carbon monoxide in an air free sample of flue gas.

$$\text{Dilution Factor} \times \frac{\text{CO (PPM)}}{10,000} = \frac{\text{_____}}{\text{\% Carbon Monoxide}}$$

Result must not exceed 0.08% carbon monoxide.

CARBON DIOXIDE IN SAMPLE (PERCENT)	FACTOR PROPANE GAS	FACTOR NATURAL GAS
4.0	3.50	3.05
4.2	3.33	2.90
4.4	3.18	2.77
4.6	3.04	2.65
4.8	2.92	2.54
5.0	2.80	2.44
5.2	2.69	2.34
5.4	2.59	2.26
5.6	2.50	2.18
5.8	2.41	2.10
6.0	2.33	2.03
6.2	2.26	1.97
6.4	2.19	1.91
6.6	2.12	1.85
6.8	2.06	1.80
7.0	2.00	1.74
7.2	1.94	1.70
7.4	1.89	1.65
7.6	1.84	1.61
7.8	1.79	1.56
8.0	1.75	1.53
8.2	1.71	1.49
8.4	1.67	1.45
8.6	1.63	1.42
8.8	1.59	1.39
9.0	1.56	1.36
9.2	1.52	1.33
9.4	1.49	1.30
9.6	1.46	1.27
9.8	1.43	1.24
10.0	1.40	1.22

KETTLE VENTING INSTRUCTIONS

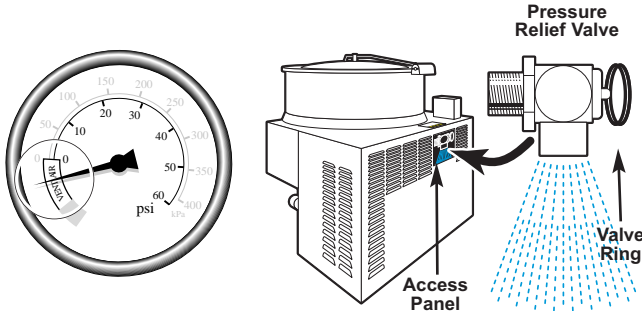

The following venting procedure should be followed when the Vacuum/Pressure Gauge needle is in the "VENT AIR" zone:

NOTE: Check for and eliminate leaks prior to venting (see REPAIRING LEAKS IN STEAM JACKETED KETTLE FITTINGS).

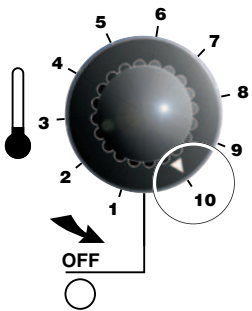

1. Remove Access Panel from back of main kettle console.
2. Turn kettle ON and set temperature control to **10**, heat the empty kettle until unit cycles off.
3. Vent kettle by pulling Valve Ring eight to fifteen times, holding valve open for two seconds each time.

NOTE: If unit cycles ON, stop venting and wait for kettle to cycle OFF before continuing.

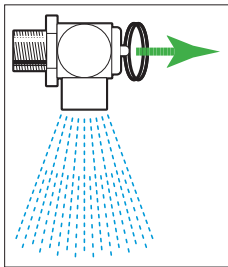

4. Turn kettle OFF. Add cold water to kettle until its surface temperature is below 100°F. The pressure gauge needle should be in the green zone, indicating a vacuum in the kettle's jacket.

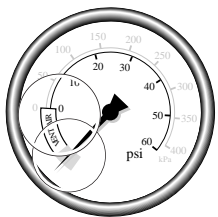

5. If needle is in the green zone then venting was successful. If not repeat procedure.

REPAIRING LEAKS IN STEAM JACKETED KETTLE FITTINGS

If unit will not hold a vacuum the most likely cause is a leak at one of the fittings. Often, the easiest way to eliminate a leak is reseal the suspect areas.

1. Water Level Probe
Remove, clean threads, apply teflon thread sealant and reinstall.
2. Pressure Relief Valve
A/ Inspect for signs of leaks. Replace if required.
B/ Remove, clean threads, apply teflon thread sealant and reinstall.
3. Pressure Gauge
A/ Inspect face of gauge. If it contains moisture on the inside of face replace.
B/ Check tightness of plumbing connection to pressure Gauge.
3. Sight Glass
A/ Check tightness of sight glass.
B/ Replace "O" ring if required.

LUBRICATION PROCEDURE

Lubricate the following parts every three months to ensure smooth operation and reduce wear.

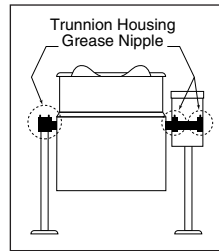

KETTLE TRUNNIONS

On the left hand side of the kettle there are two grease nipples on the top back portion of the trunnion housing. On the right hand side of the kettle you must remove the console cover to access the two grease nipples.

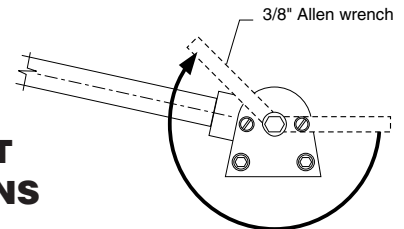

HINGE ADJUSTMENT INSTRUCTIONS

1. Insert 3/8" Allen wrench.
2. Turn clockwise to relieve tension on spring.
3. While tension is released remove one of the two slotted screws.
4. To prevent Allen wrench from springing back abruptly while the second slotted screw is removed, insert a pin (approximately 1/8") in the hole where the first slotted screw was removed from.
5. Remove second slotted screw.
6. While holding Allen wrench remove pin.
7. Turn Allen wrench clockwise to tighten or counter-clockwise to loosen tension to produce desired effect. Re-insert pin in one of the two holes.
8. Tighten one slotted screw in the other hole (it may be necessary to turn Allen wrench slightly to align holes).
10. Remove pin and repeat step number 9 for other slotted screw.

KETTLE JACKET CLEANOUT AND PASSIVATION PROCEDURES

The following procedure should be performed at least once every three years to prevent possible corrosion and ensure the optimum life of the kettle.

RUST INHIBITOR

Use a "radiator rust inhibitor" that can be purchased at your local automotive centre. It should not contain any anti-freeze and preferably no lubricant.

To ensure satisfactory mixing follow the manufacturer's instructions.

DISPOSAL - Follow all Federal, State and local codes when disposing of product.

DANGER:



Rust inhibitor can be dangerous. Read label and follow safety instructions.

WARNING:



Improper refilling of kettle jacket will result in irreversible damage to unit.

RESERVOIR FILL PROCEDURES

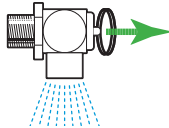

Important-
Pull ring on Pressure Relief Valve prior to removal to ensure vessel is not pressurized.

The kettle's water level must be maintained at the proper level. Under normal operating conditions, the sealed water reservoir should never require the addition of water.

If the red "low water" light comes on during use (while the kettle is in an upright position), the water level has reached a critically low level. The low water protection control has automatically shut off the gas burner. The following procedure must be completed before further use:

NOTE: Have a qualified service technician repair the leakage problem and add water to the unit. Ensure that the red "low water" light is on when the kettle is upright. On tilting kettles, it is normal for the red light to come on when the kettle is in a tilted position.

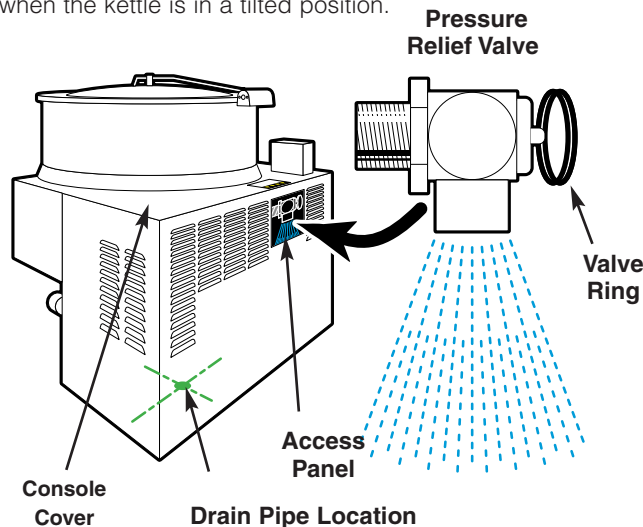

Remove the cap from the drain pipe to drain kettle jacket.

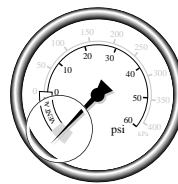

- 1. Caution:** Ensure kettle is at room temperature and pressure gauge showing zero or less pressure.
2. Shut off and disconnect gas supply.
3. Remove electrical plug from power source.

5. Pull ring on pressure relief valve to ensure there is no pressure within the kettle jacket.
6. Remove pressure relief valve.
7. Replace pressure relief valve with street elbow (see above illustration).
8. Remove or loosen water sight glass on the kettle.
9. Tilt kettle on its side (sight glass opening facing downwards) and allow to drain. Flush out with water.
10. Tilt kettle upright, apply a thread sealant (i.e. Teflon tape) to the sight glass threads and replace.
11. Refer to chart below to determine the required volume of water.



Sight Glass

Kettle Size	Volume of Mixture	
	U.S. Gal.	Liters
60 U.S. Gal.	6.5	24.6
80 U.S. Gal.	7	26.5
100 U.S. Gal.	7.5	28.4

12. In a separate container mix water with the required rust inhibitor.
13. Fill jacket via the street elbow with the mixture.
14. Remove street elbow.
15. Apply a thread sealant (i.e. Teflon tape) to the pressure relief valve and replace.
16. Reconnect gas and electrical supplies.
17. Turn kettle on, vent and heat to high for 1/2 hour.
18. Cool kettle.
19. Repeat steps 5-15.
20. Replace bolts holding kettle to tabletop.
21. Reconnect gas and electrical supplies.
22. Turn kettle on and vent kettle.

NATURAL GAS TO PROPANE CONVERSION KIT

DANGER:



Unit exhaust contains carbon monoxide. Operate only under a properly functioning hood with adequate makeup air.

THIS CONVERSION KIT SHALL ONLY BE INSTALLED BY A QUALIFIED SERVICE AGENCY

For use at 0-2000 feet elevation on Honeywell valves Model 8305. For higher elevations consult the factory.

Conversion Parts Required

Kit Service #KE003716-4)

Part No.	Description	Quantity
KE603911-4	Conversion Label	1
KE53403-7	Gas Orifice	1
FA05002-29	"O" Ring	1
KE603910-3	Instruction Seet	1

Air Intake Washer (KE54420-1) is required for 50Hz units - see conversion kits KE003716-6 & KE003716-7.

WARNING:

This conversion kit shall be installed by a qualified service agency in accordance with the manufacturer's instructions and all applicable codes and requirements of the authority having jurisdiction. If the information in these instructions is not followed exactly, a fire, and explosion or production of carbon monoxide may result causing property damage, personal injury or loss of life. The qualified service agency is responsible for the proper installation of this kit. The installation is not proper and complete until the operation of the converted appliance is checked as specified in the manufacturer's instructions supplied with the kit.

CAUTION

The gas supply shall be shut off prior to disconnecting the electrical power, before proceeding with the conversion.

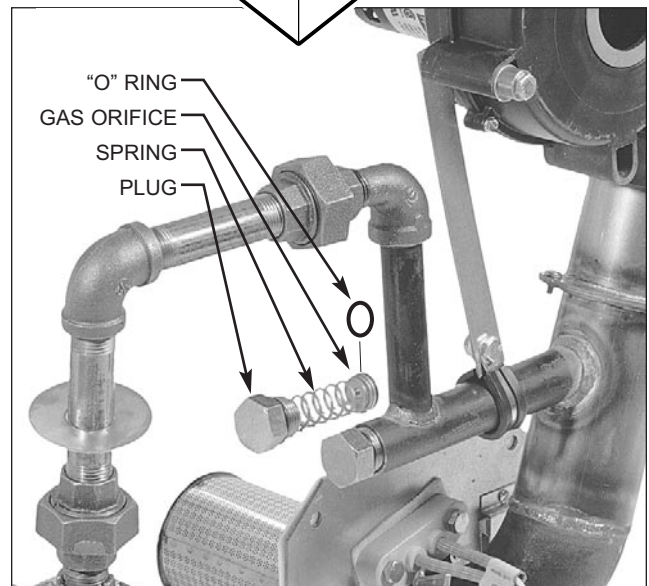
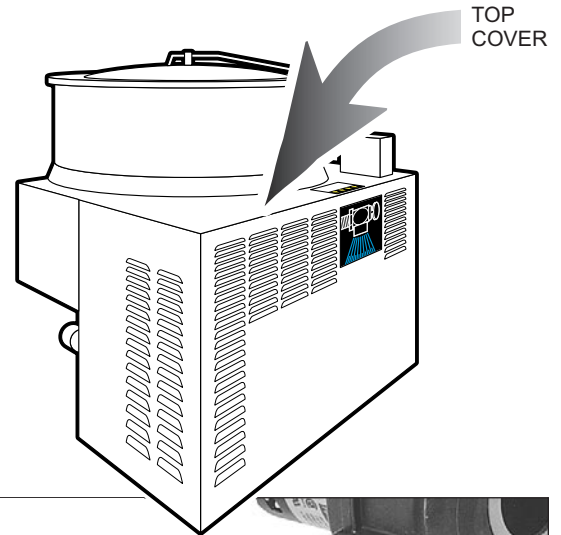

INSTRUCTIONS

NOTE: Use thread sealant compatible with propane gas on all threaded piping connections.

1. Disconnect electrical connection.
2. Shut off main gas supply and disconnect kettle from supply line.
3. Remove **TOP COVER**.
4. Remove **PLUG** and **SPRING**.
5. Remove **GAS ORIFICE** and **"O" RING**.
6. Replace with new **GAS ORIFICE** and **"O" RING**.
7. Replace **SPRING** and **PLUG**.
8. Replace **TOP COVER**.
9. Check inlet pressure is between 12-14 inches W.C.
10. Check input rate of unit.
11. On the underside of the console cover with indelible marker place the following information: Company, Name, Address & Date of Conversion.
12. Replace **TOP COVER**.
13. Place gas conversion label next to rating label.
14. Reconnect electrical and gas supplies.

AC INVERTER PROGRAMMING INSTRUCTIONS

The WFC Series AC Inverters come wired for external use and must be installed for use in a side panel control (See WIRING DIAGRAMS). Refer to owners manual for complete instructions and explanations. Manual used for the following was FORM 1094.

After installation is complete the inverter must be reprogrammed to Cleveland's modifications of the factory settings. All modifications are achieved in Access Level 2.

1. Turn agitator power on. The top four LED indicators will illuminate momentarily - wait for the three green LED's to go out before proceeding.
2. Press the PROGRAM and SHIFT keys simultaneously to reach Access Level 2. The display display will now read:
3. Use the UP/DOWN arrow keys to select the program parameter for change.
4. Press the SHIFT key. The program number will blink indicating that that the data value may be changed.
5. Use the UP/DOWN arrow keys to select the new data code.
6. Press the ENTER key. The display will indicate ****STORED**** for one second, then revert to the normal parameter display.
7. Press the PROGRAM key to exit the programming mode or the UP/DOWN keys to select an new parameter for change.

PROGRAM CODE SUMMARY:

#	Name	Description	Data Range	Factory Setting	Units	Access Level	Customer Setting
01	MODEL	Model Number	0-65000	Note 1	---	1	
02	RVLVL	Software Revision	0-640	Note 1	---	2	
03	IRAT	Rated Current	2-200	Note 1	A	2	
05	SERNO	Serial Number	0-65000	---	---	2	
06	REP	Repair Date	0-65000	---	---	2	
07	FLT3	Last Fault	---	---	---	1	
08	FLT2	2nd Fault	---	---	---	2	
09	FLT1	1st Fault	---	---	---	2	
12	FOUT	Output Frequency	0-400	---	Hz	1	
13	VOUT	Output Voltage	0-100	---	%	1	
14	IOUT	Output Current	0-650	---	A	1	
15	LOAD	Drive Load	0-200	---	%	1	
16	TORQ	Load Torque	0-200	---	%	1	
17	TEMP	Inverter Temp	2-105	---	C	1	
18	TIME1	Total Run Time	0-65000	---	h	2	
19	TIME2	Power On Hours	0-65000	---	h	2	
21	MODE	Input Mode	0-36	0	---	1	4
24	FSEL	Reference Select	0-18	0	---	2	
27	TLSEL	Torque Limit Select	0-6	0	---	2	
31	FMIN	Min. Frequency	0.00-400	0	Hz	1	14
32	FMAX	Max. Frequency	20.00-400	60	Hz	1	70
33	F2	Preset Speed #2 - Jog	0.00-400	5	Hz	1	
34	F3	Preset Speed #3	0.00-400	20	Hz	2	
35	F4	Preset Speed #4	0.00-400	40	Hz	2	
36	F5	Preset Speed #5	0.00-400	60	Hz	2	
37	F6	Preset Speed #6	0.00-400	0	Hz	2	
38	F7	Preset Speed #7	0.00-400	0	Hz	2	
39	FTL	Min. Frequency in Torque Limit	0.00-400	10	Hz	2	
41	RSEL	Ramp Selector	0-7	0	---	2	
42	ACC1	Acceleration Time #1	0.10-600	3	s	1	9

43	DEC1	Deceleration Time #1	0.10-600	3	s	1	1
44	ACC2	Acceleration Time #2	0.10-600	1	s	2	
45	DEC2	Deceleration Time #2	0.10-600	1	s	2	
46	DECTL	Torq. Limit Response Time	0.10-30	1	s	2	
47	DCBRK	DC Brake Time	0-5	0.2	s	2	
48	DCVLT	DC Brake voltage	0-15	Note1	%	2	
51	VSEL	V/Hz Characteristic Selector	0-5	0	---	2	2
52	BOOST	Torque Boost	0-25	Note 1	%	1	8
53	FKNEE	V/Hz Knee Frequency	26-640	60	Hz	2	75
54	SKBND	Skip Fresq. Hysteresis Band	0.20-20	1	Hz	2	
55	SK1	Skip Frequency #1	0.00-400	0	Hz	2	
56	SK2	Skip Frequency #2	0.00-400	0	Hz	2	
57	SK3	Skip Frequency #3	0.00-400	0	Hz	2	
58	SK4	Skip Frequency #4	0.00-400	0	Hz	2	
59	MVOLT	Rated Motor Voltage	185-480	Note 1	V	2	
61	LTLF	Load Torq. Limit Forward	5-150	150	%	2	
62	LTLR	Load Torq. Limit Reverse	5-150	150	%	2	
63	RTLFL	Regenerative Torq. Limit FWD	5-110	80	%	2	
64	RTLRL	Regenerative Torq. Limit REV	5-110	80	%	2	
65	SLIP	Slip Compensation	0-10*	0	%	1	
66	STAB	Current Stability	0-5	2	---	2	
67	TOL	Timed Overload Trip Point	0-100	0	%	2	100
68	NRST	Restart Number	0-8	0	---	2	
69	DRST	Restart Delay	0-60*	0	s	2	
6C	TOLC	Timed Overload Characteristic	0-7	0	---	2	
71	METER	Analog Meter Output	0-7	1	---	1	
72	ST1	Auxiliary Output #1	0-11	6	---	2	
73	ST2	Auxiliary Output #2	0-11	3	---	2	
74	ST3	Auxiliary Output #3	0-11	7	---	2	
75	STR	Auxiliary Relay (Fault)	0-11	2	---	2	3
81	PRGNO	Special Program Number	0-65000	0	---	2	2
82	START	Inverter Start Options	0-7	0	---	2	
83	PWM	Carrier Frequency Selector	0-1	0	---	2	1
84	DISP	Display Option Full Setting	0-65000	0	---	2	
85	UNITS	Display Units	ALPHA	RPM_1	---	2	
86	LANG	Display Language	0-3	0	---	2	
87	ACODE	Security Access Code	0-999	0	---	2	
A2	RATIO	Master Slave Speed Ratio (Note 2)	50-2000	100	%	2	
B1	OPTNO	Option Board Number	0-6	0	---	2	
Cx	CNTLx	Event Control (1-9)	BINARY (8)	0	---	2	
Ex	ECNTx	Event Counts (1-9)	0-65535	0	---	2	

Bolded areas indicate Cleveland modifications of factory settings.

HA DRIVE SHAFT REPLACEMENT PROCEDURE

Note: Disconnect external power supply and shut off gas to unit prior to servicing.



1. Remove mixer arm leaving flat surface on drive shaft facing upwards.

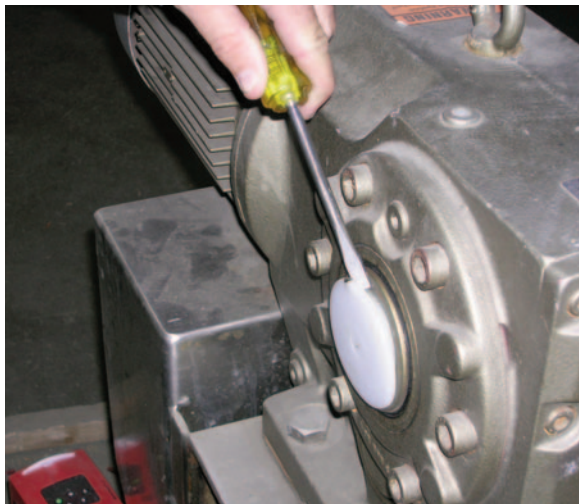

2. Remove shaft end cap.

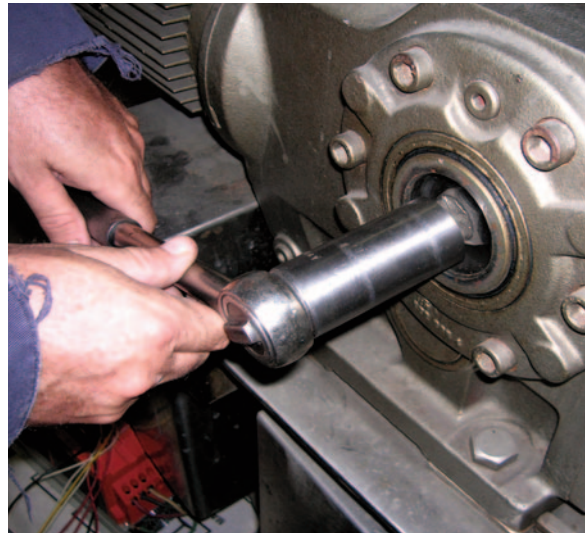

3. Remove shaft retaining bolt.



4. Remove shaft retaining ring.



5. Gently hammer out shaft and remove.



6. Clean seal.



7. Grease seal with food grade grease.

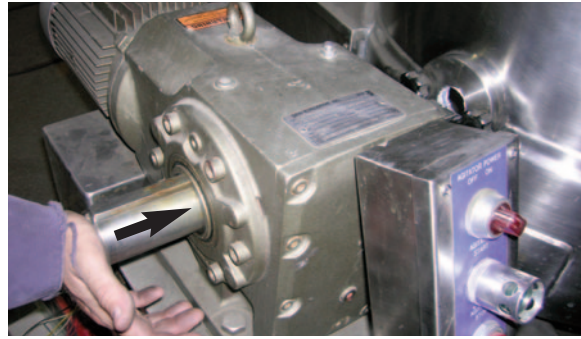

8. Insert new shaft.



9. Push new shaft past retaining ring groove and install retaining ring.



10. Tap shaft back to seat up against retaining ring.

11. Complete reassembly by reinstalling bolt and end cap.

WIRING DIAGRAM - 208-240V (Page 1 of 2)

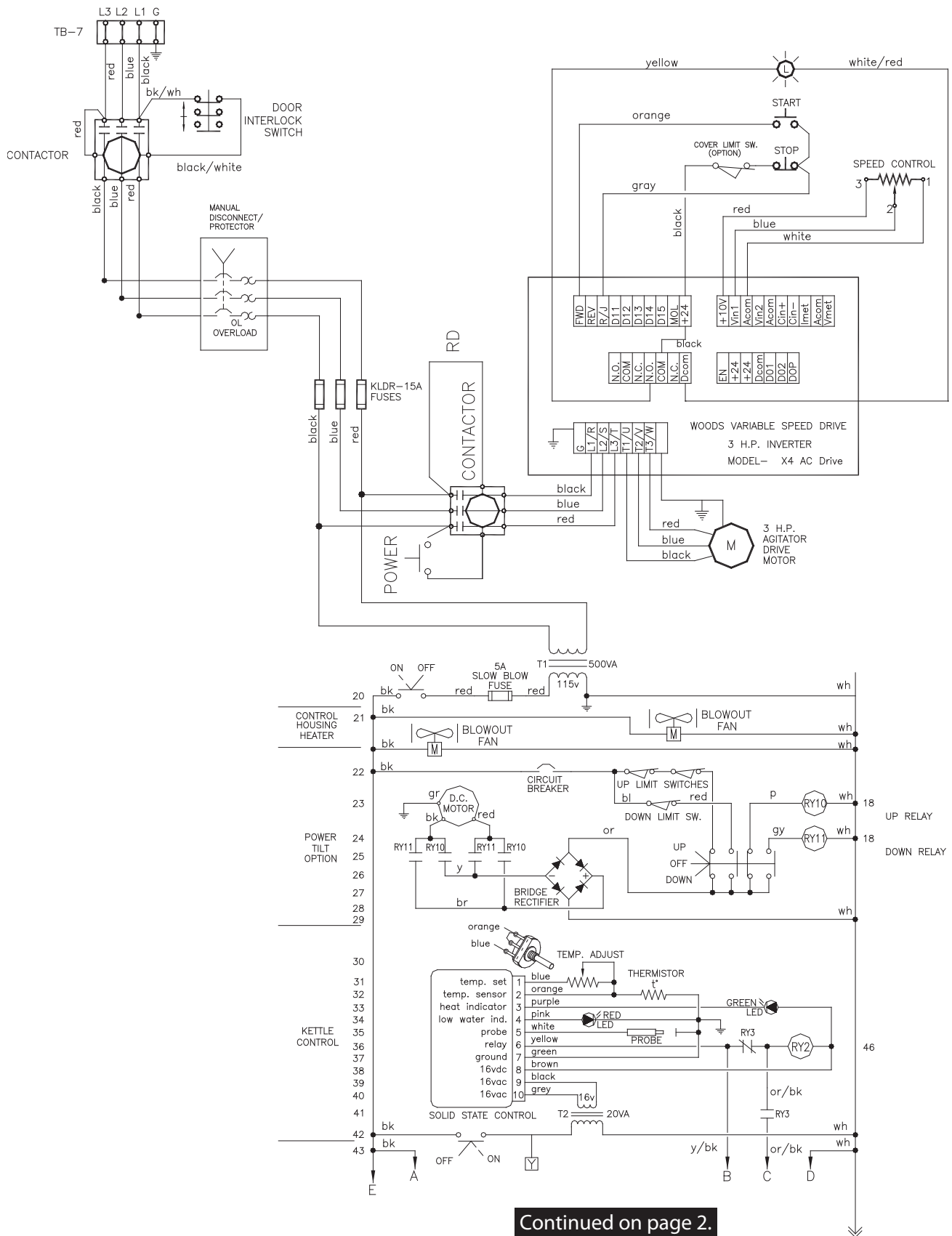

Continued on page 2.

WIRING DIAGRAM - 208-240V (Page 2 of 2)

Continued from page 1.

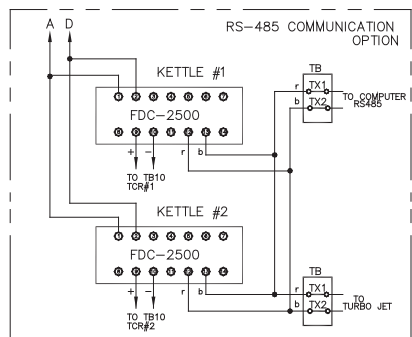
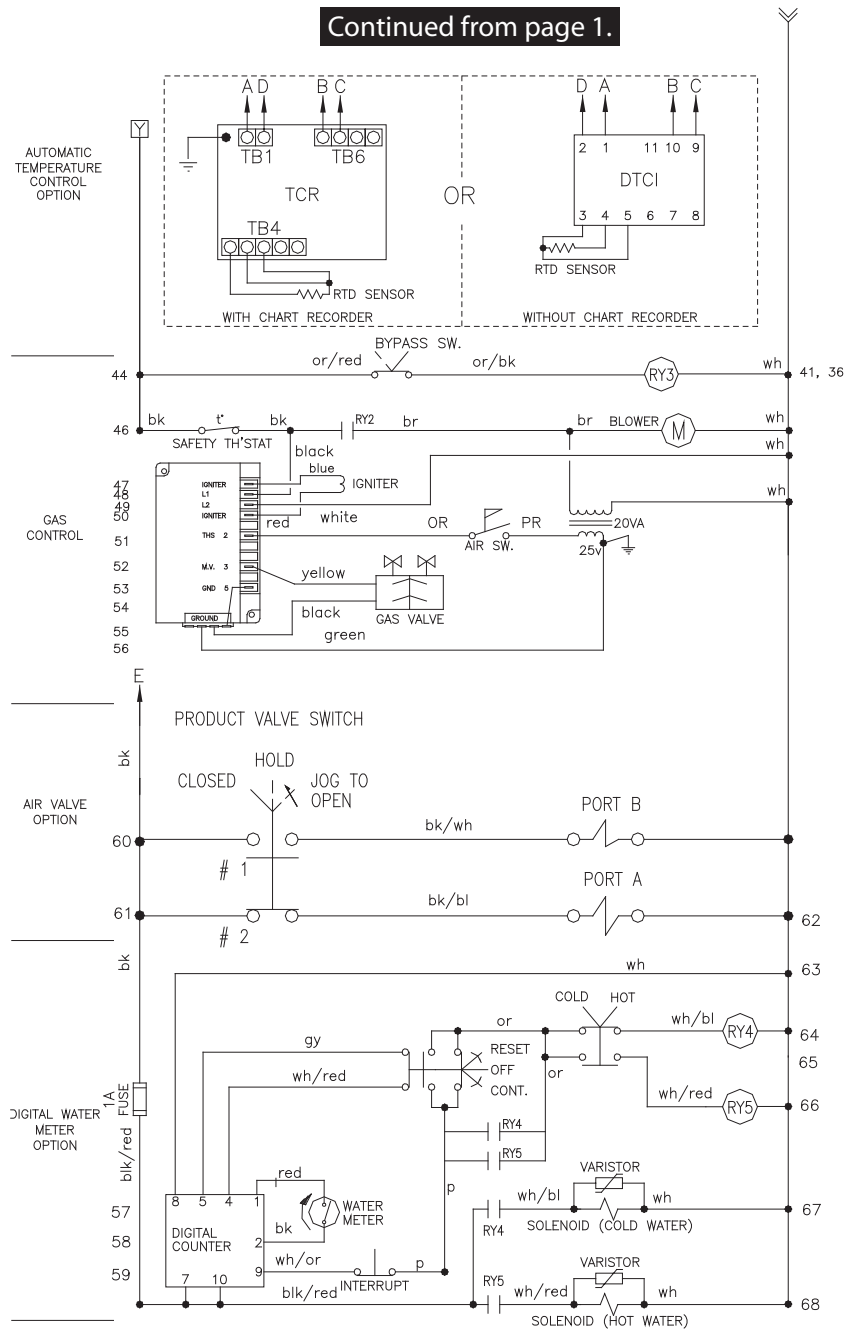

MAINTAINED, MAINTAINED, MOMENTARY

	#1	#2
SWITCH		
CLOSED	O	X
HOLD	O	O
JOG TO OPEN	X	O
CONTACT		

X = CLOSED
O = OPEN

HA-SG-CC (200-240 V)

WIRING DIAGRAM - 460-480V (Page 1 of 2)

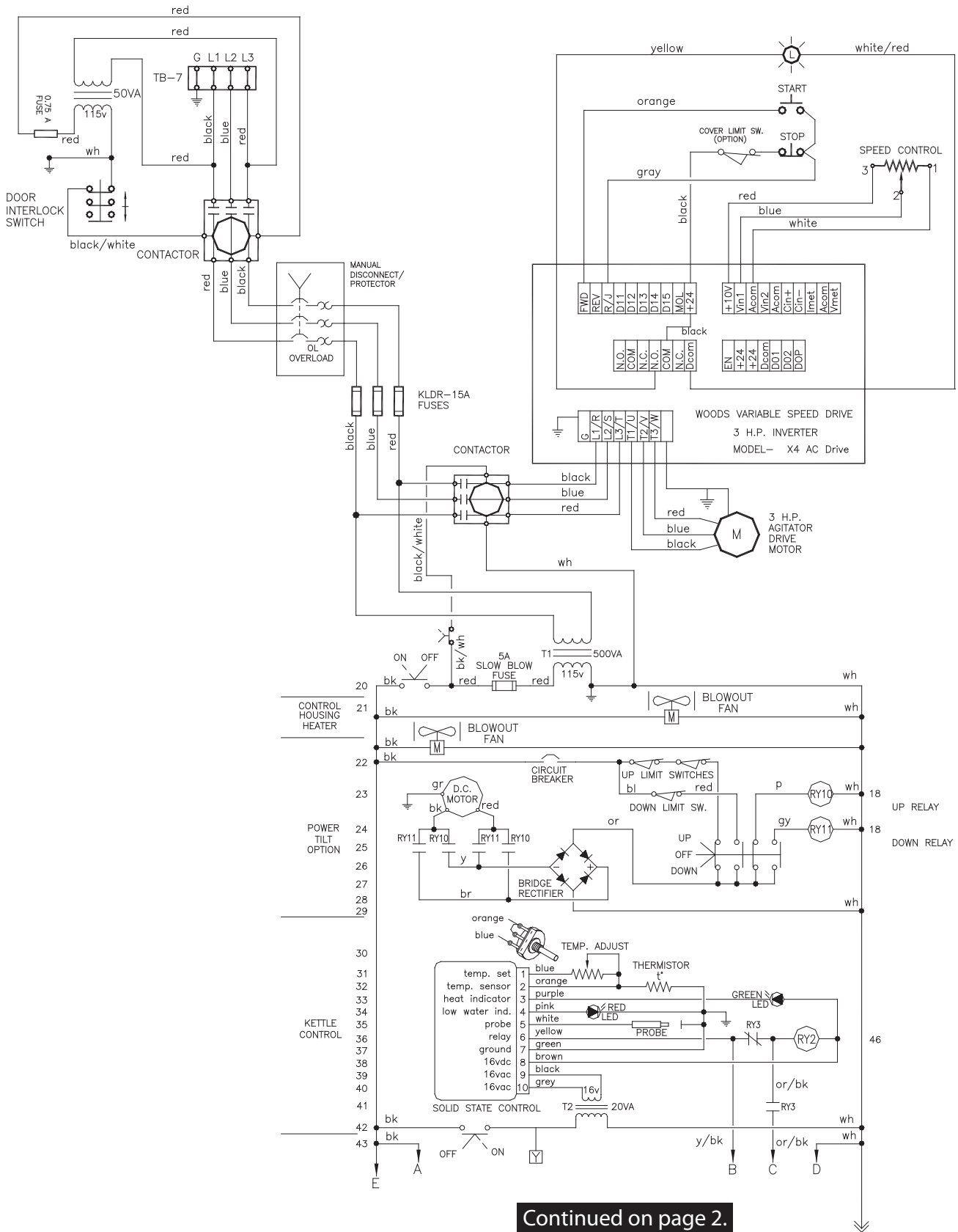

Continued on page 2.

WIRING DIAGRAM - 460-480V (Page 2 of 2)

Continued from page 1.

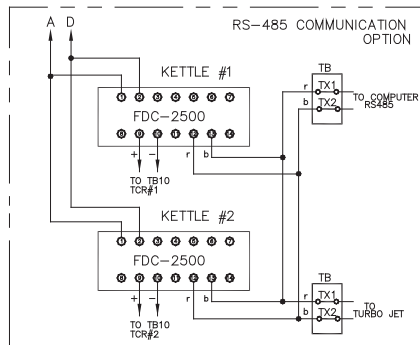
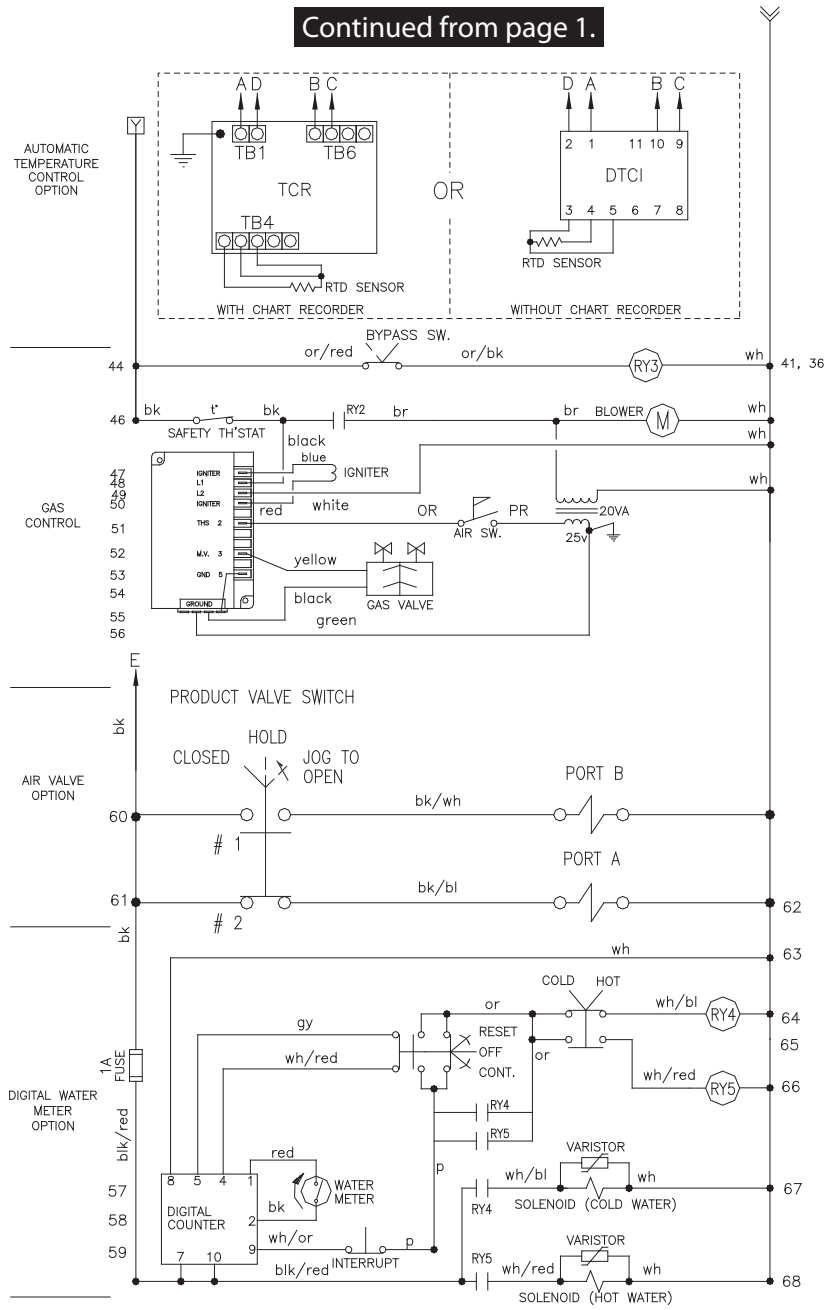

MAINTAINED, MAINTAINED, MOMENTARY

SWITCH	#1	#2
CLOSED	O	X
HOLD	O	O
JOG TO OPEN	X	O
CONTACT		

X = CLOSED
O = OPEN

HA-MKGL/-T WITH
ALL OPTIONS (460-480 V)

SERVICE PARTS

WRAP COVERS

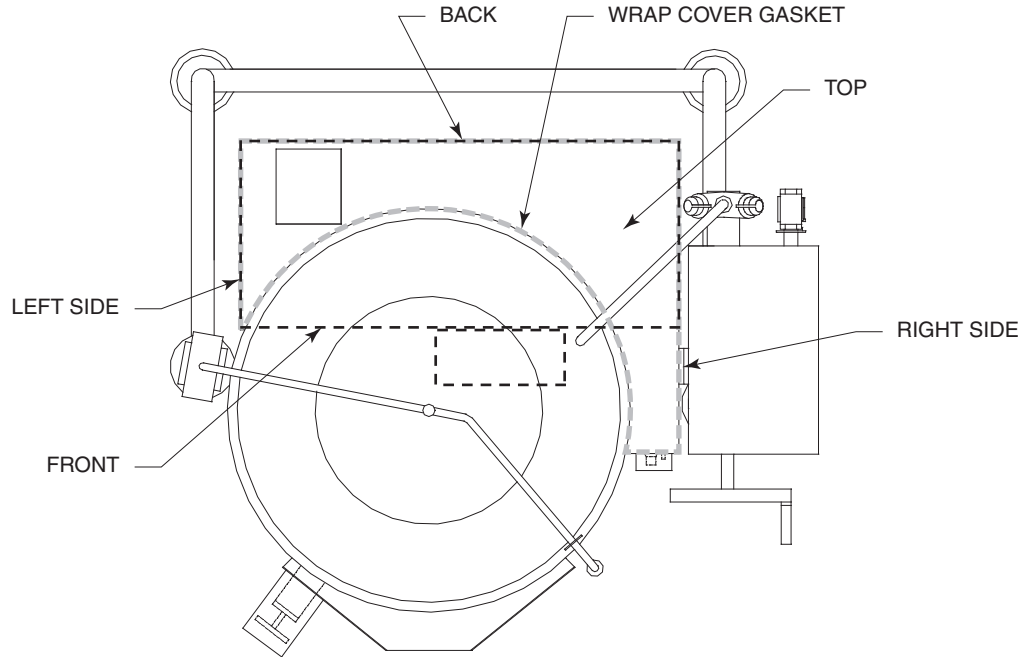

KETTLE	TOP (c/w gasket)	FRONT	LEFT SIDE	RIGHT SIDE	BACK	SERVICE WRAP COVER GASKET
HAMKGL-60	KE01479-1	KE53483-5	KE54253-1	KE01432-1	KE02186-2	SKE54419-2
HAMKGL-80	KE01479-2	KE53483-6	KE54253-2	KE01432-2	KE02186-3	SKE54419-3
HAMKGL-100	KE01479-3	KE53483-7	KE54253-3	KE01432-3	KE02186-4	SKE54419-4
HAMKGL-60-T	KE01479-1	KE53483-1	KE54253-1	KE01432-1	KE02186-2	SKE54419-2
HAMKGL-80-T	KE01479-2	KE53483-2	KE54253-2	KE01432-2	KE02186-3	SKE54419-3
HAMKGL-100-T	KE01479-3	KE53483-7	KE54253-3	KE01432-3	KE02186-4	SKE54419-4

HINGE ASSEMBLY

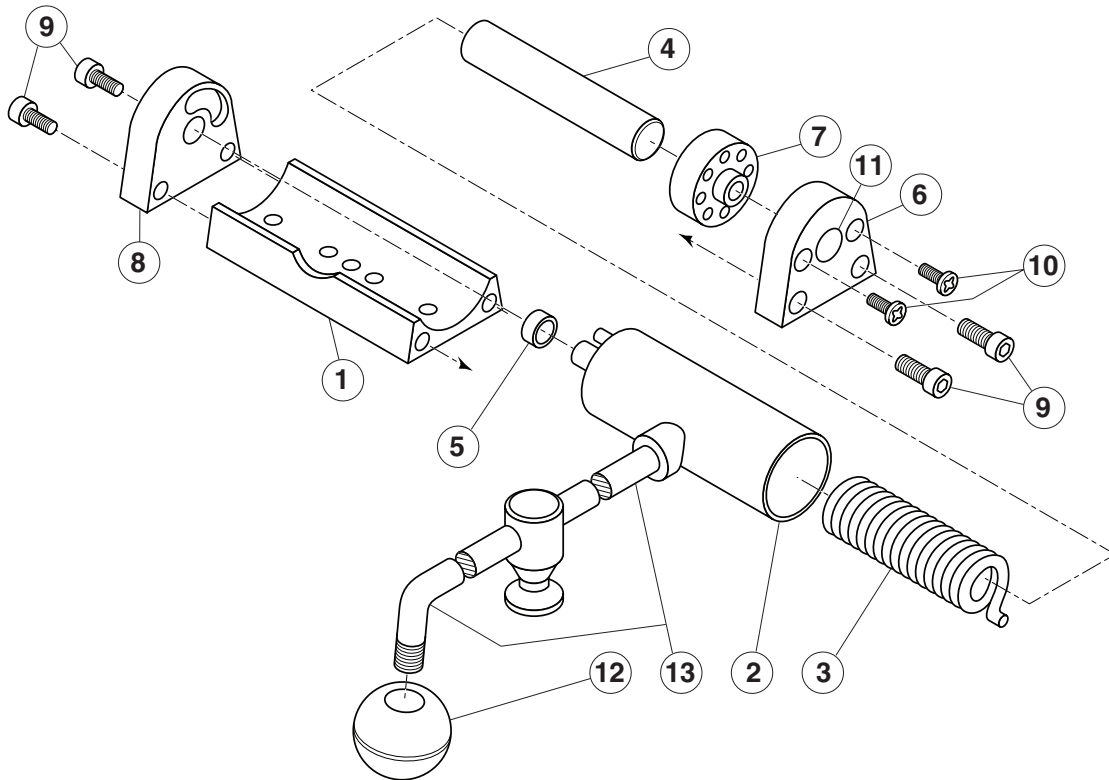

-	KE00597-7	HINGE ASS'Y; 60-100 GALLONS, 30-60F (HEAVY SPRING), LH					▼
-	KE00597-6	HINGE ASSY; 25 GALLONS (100 DEG. OPENING, LIGHT SPRING)				▼	
-	KE00597-4	HINGE ASSY; KGL-40TSH, HA-MKGL, KDM60T/CT (100 DEG. OPENING, HEAVY SPRING)			▼		
-	KE00597-2	HINGE ASS'Y; 60-100 GALLONS, 30-60F (HEAVY SPRING)		▼			
-	KE00597-1	HINGE ASSY; 30-40 GALLONS, 20F, KDM25-40T/CT (LIGHT SPRING)	▼				
ITEM	PART #	DESCRIPTION	QTY	QTY	QTY	QTY	QTY
1	KE50822	HINGE BASE; CHS	1	1	1	1	1
2	KE51217	HINGE CYLINDER	1	1	1	1	1
3	KE50121-1	HINGE SPRING; HEAVY (0.187DIA/12 COILS)	-	1	1	-	-
	KE50121-2	HINGE SPRING; LIGHT (0.162DIA/16 COILS)	1	-	-	1	-
	KE50121-3	HINGE SPRING; HEAVY (0.187DIA/12 COILS) LH	-	-	-	-	1
4	KE50823-1	HINGE PIN; LIGHT SPRING	1	-	-	1	
	KE50823-2	HINGE PIN MODIFD; HEAVY SPRING	-	1	1	-	-
5	KE50824	HINGE BEARING; MODIFIED	1	1	1	1	1
6	KE50819	HINGE END PIECE; RHS	1	1	1	1	1
7	KE50820	HINGE INSERT; CHS	1	1	1	1	1
8	KE50819-1	HINGE END PIECE; LHS	1	1	-	-	-
	KE50819-2	HINGE END PIECE; LHS MODIFIED (TO 100 DEGREE)	-	-	1	1	-
9	FA11284	SCREW; 1/4-20 X 1/2" HEX SOCKET	4	4	4	4	4
10	KE50819-3	HINGE END PIECE; LHS	-	-	-	-	1

FAUCETS

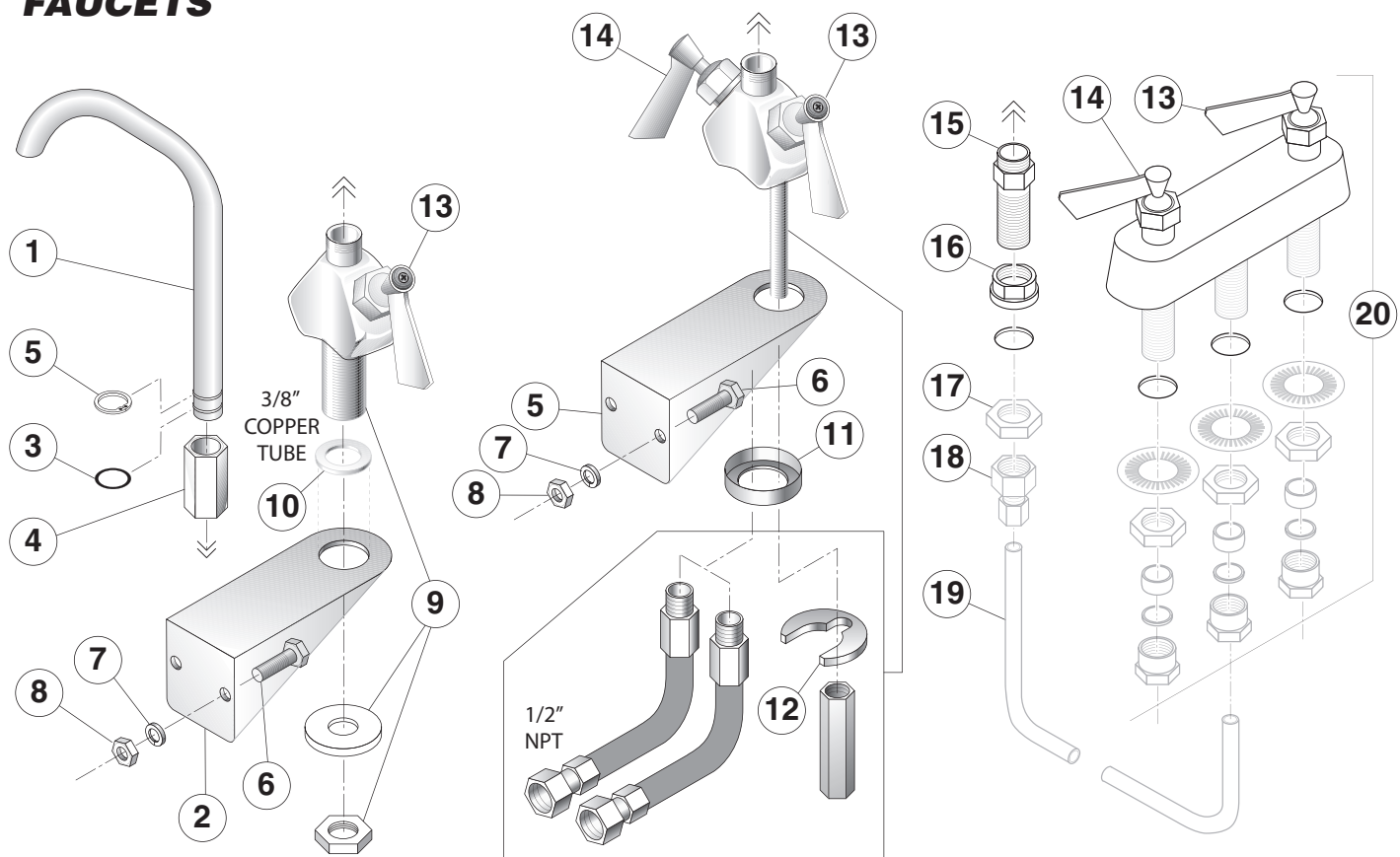

Common Parts

ITEM #	PART #	DESCRIPTION	QTY.
	SPK ____	SINGLE PANTRY FAUCET KIT , (includes items 1-10) see next page for ordering information	
	DPK ____	DOUBLE PANTRY FAUCET , (includes items 1-8 & 11) see next page for ordering information	
1.	KE50825- ____	SPOUT , see next page for ordering information	
2.	_____	FAUCET MOUNTING BRACKET , see next page for ordering information	1
3.	FA05002-19	"O" RING	1
4.	KE51736	LONG FAUCET NUT	1
5.	FA95007-10	RETAINING RING	1
6.	FA11258	HEX CAP SCREW	2
7.	FA31029	LOCK WASHER	2
8.	FA21008	HEX NUT	2
9.	KE51401	SINGLE PANTRY BODY (c/w item 13)	1
10.	KE50335	ADAPTER WASHER	1
11.	KE51403	DOUBLE PANTRY BODY (c/w item 13 & 14)	1
12.	SE50447	REPLACEMENT HORSESHOE WASHER	1
13.	SE50021	REPLACEMENT STEM ASSEMBLY, COLD WATER	1
14.	SE50020	REPLACEMENT STEM ASSEMBLY, HOT WATER	1
15.	SD50097	FLANGED NUT, 3/4" NPT, CHROME PLATED	1
16.	KE51585	FAUCET SPOUT FITTING	1
17.	SD50098	LOCKNUT, 3/4" NPT	1
18.	FI00266	COUPLING, 1/2" NPT	1
19.	SD50100	COPPER TUBE	1
20.	KE51899	REMOTE VALVE (c/w item 13 & 14)	1

FAUCETS

Models

	FAUCET KIT	BRACKET	SPOUT
KDT12/20 ON SD TABLE	SPK1 DPK1		KE50825-1
KDL60/80/100T KEL40/60/80/100T KET20 KGT,MKET, KDP60-100/T	SPK2 DPK2	KE54159 KE02071-1 (CP)	KE50825-2
KDL25/40T KEL25T,KDP25/40T	SPK3 DPK3	KE54159	KE50825-3
KDM60/T	SPK-KDM60 DPK-KDM60		KE50825-2
KDM25/40/T	SPK6 DPK6		KE50825-6
KDL40/60/80TSH KEL40/60TSH	SPK7 DPK7	KE54159	KE50825-7
KDT6 ON SD OR ST	SPK8 DPK8		KE50825-8
TKET, KET3/6/12	SPK9 DPK9	KE54159	KE50825-9
KDL125/150T KGL40/60/80T KGL40TSH	SPK10 DPK10	KE54159	KE50825-10
HAMKGL60/80/100T	SPK11 DPK11	KE54159	KE50825-11
KGL25T, T1	SPK13 DPK13	SK00395-1 KE02071-2 (CP)	KE50825-7
TR	SPK14 DPK14	SK2382300 SK2382400 (SPACER)	KE50825-6
SET10	DPK15 SPK15	SK2308800	KE50825-6
SET15	SPK16 DPK16	SK2302200	KE50825-6
HAMKGL60/80/100	DPK17 SKP17		KE50825-12
ALL STATIONARY KETTLES	DPK5 SPK5		KE50825-5

KETTLE CONTROLS

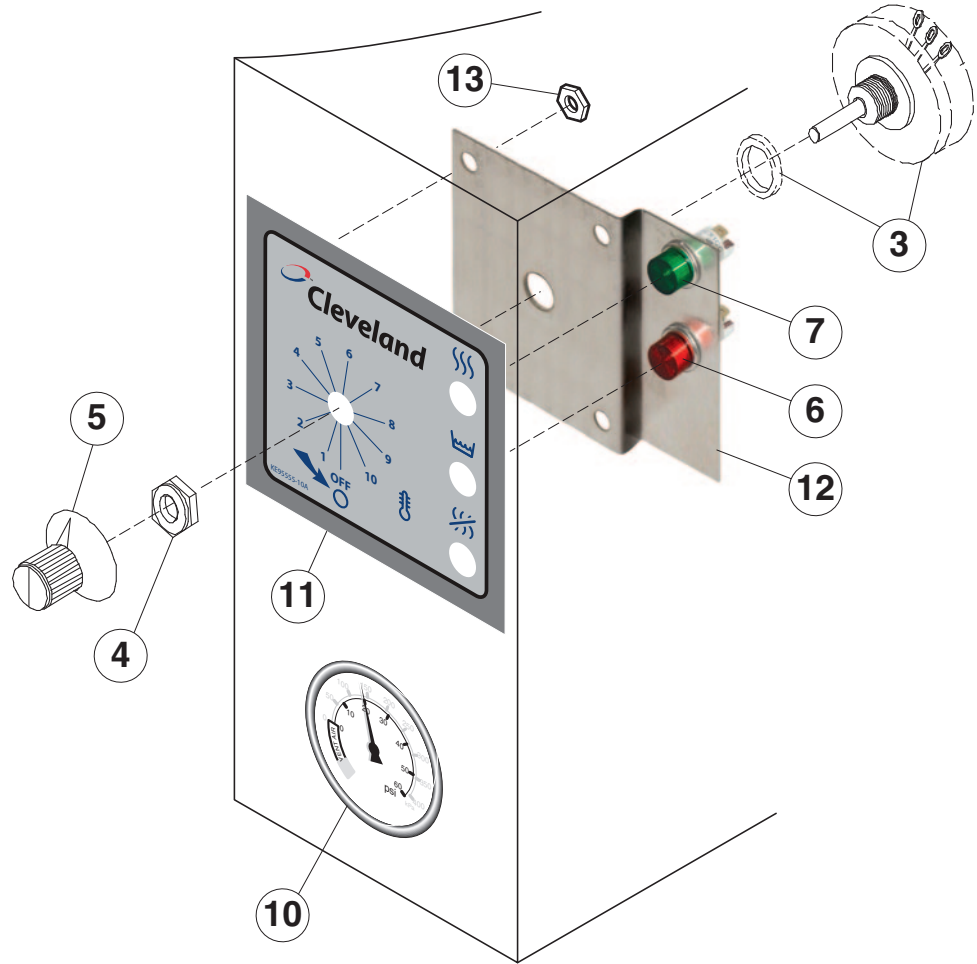

ITEM NO.	PART NO.	DESCRIPTION	QTY.
3.	SE00114	POTENTIOMETER WITH ON/OFF SWITCH, C/W ITEM #4	1
4.	KE51005	RUBBER BOOT	1
5.	KE50569-1	KNOB, POTENTIOMETER	1
6.	KE55486-2	INDICATOR LIGHT, RED	1
7.	KE55486-3	INDICATOR LIGHT, GREEN	1
10.	KE50429-6	PRESSURE GAUGE	1
11.	KE95555-10	LABEL	1
12.	KE603836	BRACKET, LIGHT	1
13.	FA21006	#10-24, HEX NUT, S.S.	4

SIGHT GLASS

ITEM ON.	PART NO.	DESCRIPTION	QTY.
1.	KE50955	RETAINING COVER	1
2.	KE52871	GASKET	1
3.	KE51053	SIGHT GLASS	1
4.	FA05002-30	"O" RING	1

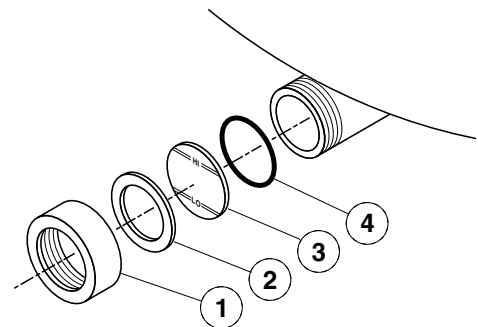

ELECTRICAL COMPONENT BOX - 115 VOLT UNITS

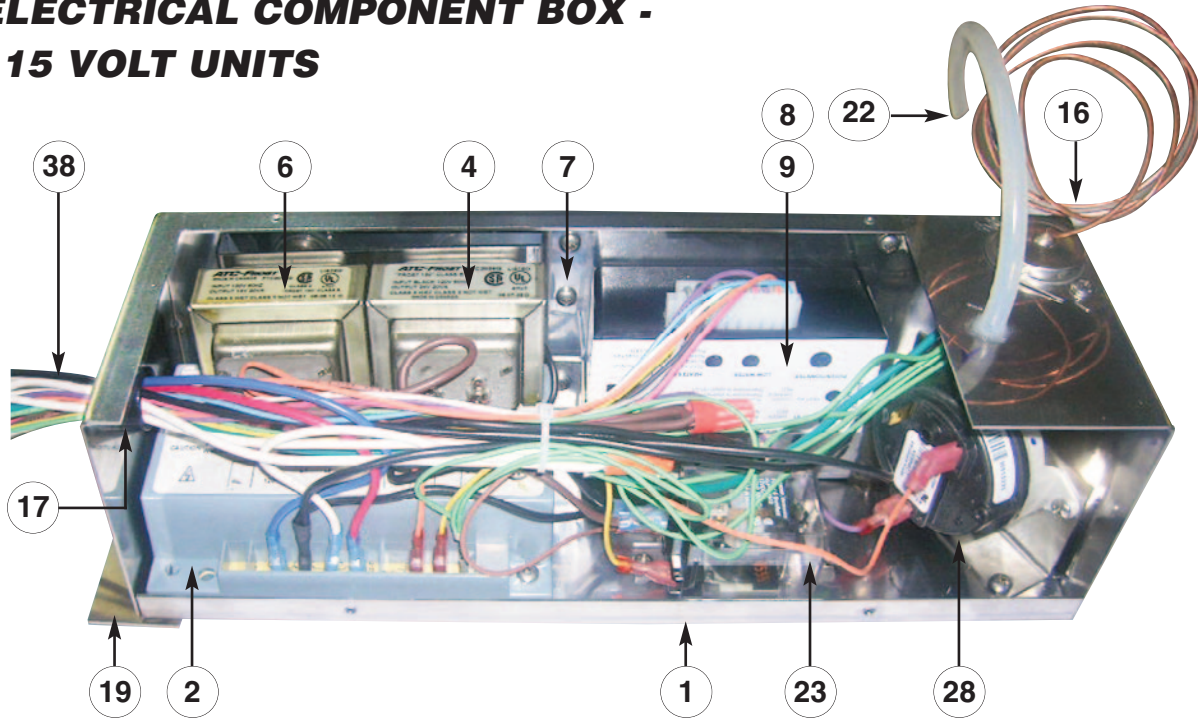

ITEM	PART #	DESCRIPTION	QTY.
1	KE003654	COMPONENT BOX WELDMENT; KGL/-T	1
2	KE53469-5	IGNITION CONTROL; KGL/T (CSA/CE/AGA APPROVED)	1
4	KE53838-20	TRANSFORMER;120 V PRIMARY/24 V SECONDARY60HZ, 20 VA	1
6	KE53838-27	TRANSFORMER;120 V PRIMARY/14 V SECONDARY60HZ, 20 VA	1
7	KE603765	TRANSFORMER BRACKET	1
8	KE00458-1	KETTLE CONTROL BOX	1
9	KE50303-1	ELECTRONIC BOX HOLDER	1
10	KE53599-1	GASKET; KGL/KGL-T	1
16	KE55069-6	THERMOSTAT;SAFETY(KGT/KGL)	1
17	KE54833-3	SNAP-IN BUSHING; 0.875 DIA.	1
18	KE53440	COVER; COMPONENT BOX (KGL/-T)	1
19	KE53620	BRACKET FOR COMPONENT BOX	1
22	KE55501-1	TUBE; AIR SWITCH	1
23	KE50753-7	RELAY; SPDT/10A/12VDC #MJN1CF-DC12	1
24	FA15018-4	SCREW; PHILIPS 8-32X3/8"L	4
25	FA15018-3	SCREW; PHILIPS 8-32X1/4"L	6
26	FA10243	SCREW; SLOT 8-32X3/4"L	2
27	FA15018-7	SCREW; PHILIPS 6-32X1/4"L	2
28	KE02400-1	AIR PRESSURE SWITCH ASSEMBLY; DOMESTIC AND CE	1
29	KE54662-1	HEAT SHRINKABLE TUBING; 3/126 ID 12" LONG	1
30	KE54661-2	VARFLO SLEEVING 12" LONG	1
31	NPN00163	CONNECTOR; MARR NO. 2	1
32	KE54668-1	TERMINAL; FULLY INSULATED AMP#2-520181-2 OR 182-2	2
33	KE50988-1	POTENTIOMETER; C/W ON/OFF SW REV LOG TAPER	1
34	KE50567-1	LIGHT; RED-WATER INDICAT #249-7867-3331-504	1
35	KE50567-3	LIGHT; GREEN-HEAT INDICAT #249-7967-3332-504	1
36	KE51005	ROTARY SEAL; #N9030 X 1/4 (AMP-HEXSEAL)	1
37	KE52412	CONNECTOR; MARR NO. 1	2
38	WHKGLT	WIRING HARNESS; KGL40-100	1

Items #10, 18, 24-27, 29-37 not show for clarity.

GAS CONTROL ASSEMBLY

Stationary Models

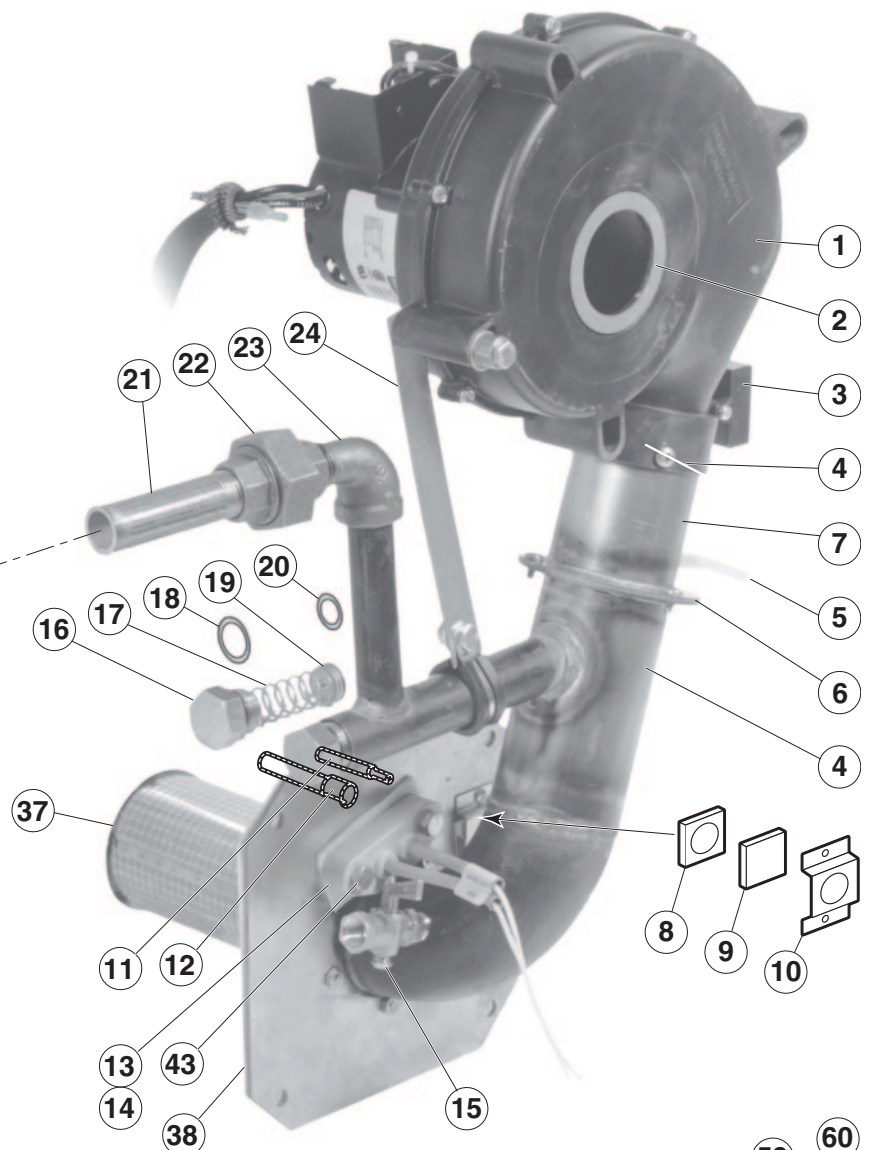
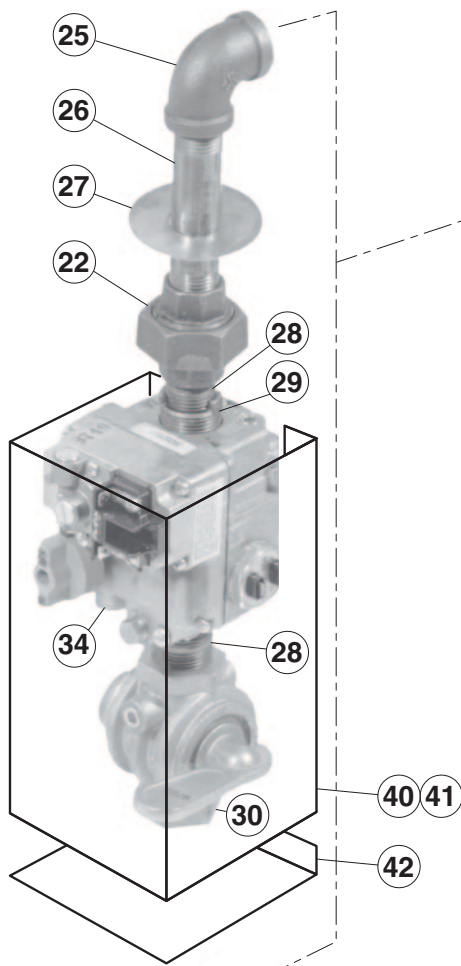

Tilting Models

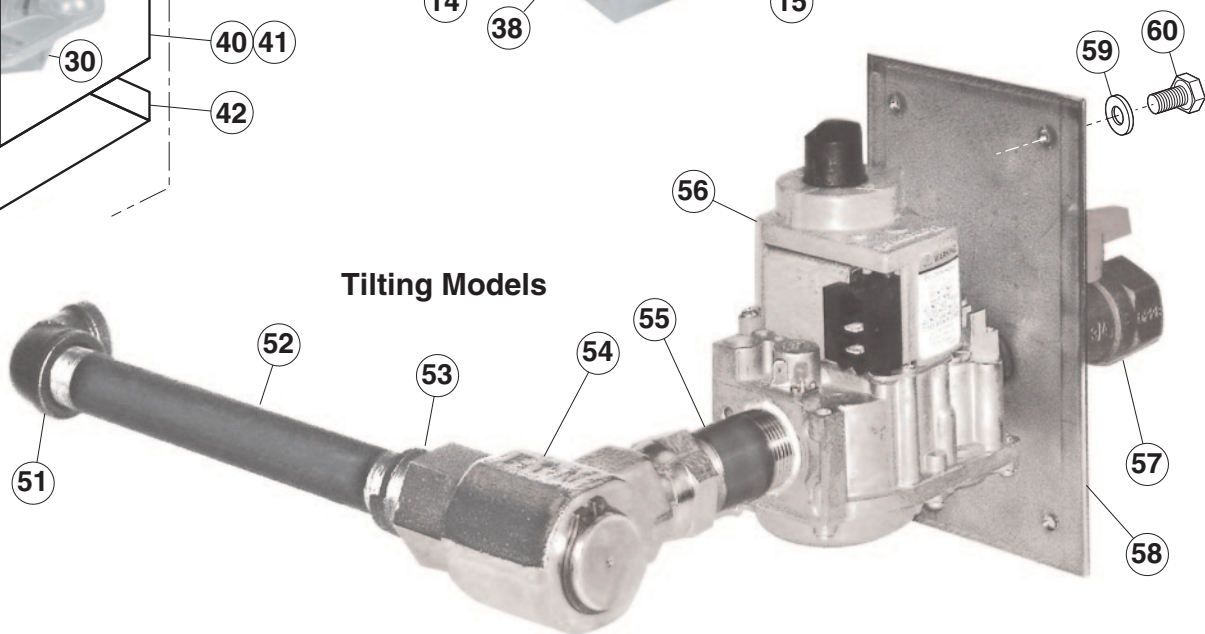

GAS CONTROL ASSEMBLY

ITEM ON.	PART NO.	DESCRIPTION	QTY.
1.	KE53441	BLOWER, 115V, 60 HZ	1
	KE53441-1	BLOWER, 220V, 50 HZ	1
2.	KE54420	AIR INTAKE WASHER (NATURAL GAS, 50hz)	1
	KE54420-1	AIR INTAKE WASHER (PROPANE, 50hz)	1
3.	KE54239	CAPACITOR	1
4.	KE01426-4	MIXING CHAMBER, 40 GALLON KETTLES	1
	KE01426-1	MIXING CHAMBER, 60 GALLON KETTLES	1
	KE01426-2	MIXING CHAMBER, 80 GALLON KETTLES	1
	KE01426-3	MIXING CHAMBER, 100 GALLON KETTLES	1
5.	KE53582	TUBING 1/4 INCH SILICONE	1
	FI05156	HOSE FITTING	1
6.	KE53402-4	AIR ORIFICE, 40 GALLON KETTLES (60hz)	1
	KE53402-1	AIR ORIFICE, 60 - 100 GALLON KETTLES (60hz)	1
	KE53402-2	AIR ORIFICE, 40 GALLON KETTLES (50 HZ BLOWER)	1
	KE53402-3	AIR ORIFICE, 60 - 100 GALLON KETTLES (50 HZ BLOWER)	1
7.	KE01449	BLOWER MOUNTING PIPE ASSEMBLY	1
8.	KE53618	SIGHT GLASS GASKET	1
9.	KE53617	SIGHT GLASS	1
10.	KE53619	SIGHT GLASS RETAINER	1
11.	KE00515	THERMISTOR	1
12.	KE50556-2	WATER LEVEL PROBE	1
13.	KE53437-3	IGNITOR	1
14.	KE53570	GASKET FOR IGNITOR	1
15.	FI05257	SHUT-OFF COCK	1
16.	FI05213	PLUG, C/W O-RING	1
17.	KE53422	SPRING	1
19.		CONSULT FACTORY FOR PROPER ORIFICE	
18.	FA05002-4	"O" RING	1
20.	FA05002-29	"O" RING	1
21.	N0440C5	NIPPLE, 1/2" NPT, 5 5/16" LONG	1
22.	FI00073	UNION, 1/2"	1
23.	FI00133	ELBOW, 1/2", STREET	1
24.	KE53909	STRIP, TO HOLD BLOWER DOWN	1
25.	FI00040-1	ELBOW, 1/2"	1
26.	N0440C4	NIPPLE, 1/2" NPT, 4" LONG, KGL-60-T	1
	N0440C3-875	NIPPLE, 1/2" NPT, 4" LONG, KGL-80-T	1
27.	KE55004-3	RETAINING PLATE	1
28.	N0640C2	NIPPLE, 1/2" NPT, 2" LONG	1
29.	FI05231	BUSHING, 3/4" - 1/2" NPT	1
30.	F01518-1	GAS SHUT-OFF VALVE, 3/4" (NOT FOR FRENCH CE KETTLES)	1
34.	KE55240R	GAS VALVE ASSEMBLY	1
37.	KE01500-5	BURNER, 40 GALLON KETTLES, 140,000 BTU	1
	KE01500-1	BURNER, 60-100 GALLON KETTLES, 190,000 BTU	1
38.	KE53397	GASKET, BURNER	1
40.	KE601085	COVER FOR GAS VALVE	1
41.	RB018151	GASKET FOR COVER	1
42.	KE601081	BRACKET	1
43.	FA15005	BOLT	2
51.	FI00040-1	ELBOW, 1/2"	1
52.	N0440C8	NIPPLE, 1/2" NPT, 8" LONG	1
53.	FI05231	ADAPTOR	1
54.	FI05222	SWIVEL ELBOW	1
55.	FI05223-6	SPECIAL NIPPLE	1
56.	KE55240R	GAS VALVE ASSEMBLY	1
57.	F01518-1	GAS SHUT-OFF VALVE, 3/4"	1
58.	KE000960	NIPPLE PLATE WELDMENT	1
59.	FA30505-1	WASHER, 1/4"	4
60.	FA11256	HEX BOLT, 1/4-20 X 1/2, 18-8 SS	4

TRUNNION HOUSING - TILTING KETTLES

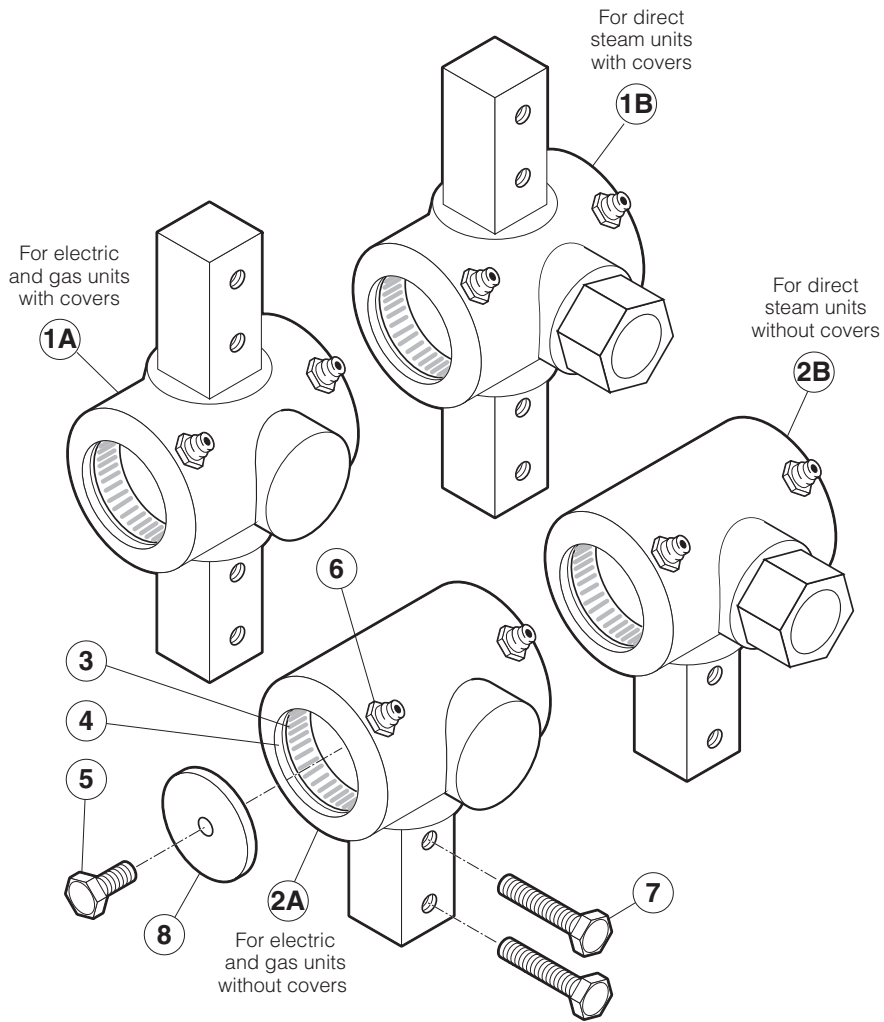

ITEM NO.	PART NO.	DESCRIPTION	QTY.
TRUNNION BEARING ASSEMBLIES (INCLUDES PART # 3, 4 & 6)			
1A.	KE00354	FOR ELECTRIC AND GAS UNITS WITH COVERS	.1
1B.	KE00353	FOR DIRECT STEAM UNITS WITH COVERS	.1
	KE003531	SERVICE HOUSING; SOLID BEARING (KDLT C/W COVER)	.1
2A.	KE00351	FOR ELECTRIC AND GAS UNITS WITHOUT COVERS	.1
2B.	KE00352	FOR DIRECT STEAM UNITS WITHOUT COVERS	.1
	KE003521	SERVICE HOUSING; SOLID BEARING (KDLT W/O COVER)	.1
3.	KE51711	ROLLER BEARING	.2
4.	KE51571-1	BEARING WASHER	.1
5.	FA95081-3	BOLT, 5/16-18 X 1/2"	.1
6.	KE51886	GREASE NIPPLE	.2
7.	FA11326	BOLT, 5/16-18 X 1 1/2"	.4/2
8.	KE50666	SPHERICAL WASHER	.1

FLUSH PISTON VALVE

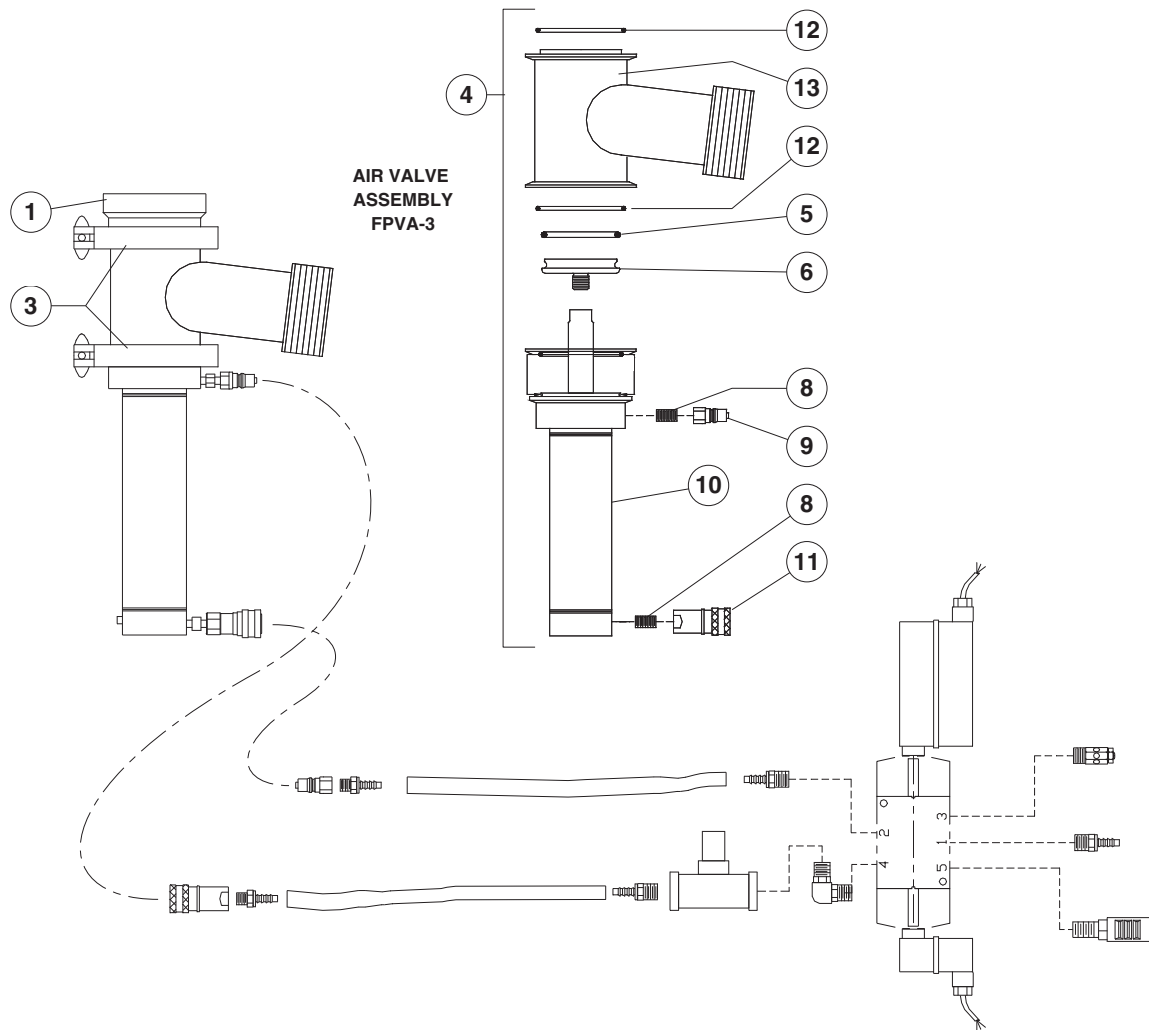

ITEM NO.	PART NO.	DESCRIPTION	QTY.
1.	KE55210	WELD RING, KETTLE BOTTOM OUTLET	1
2.	FI05144-3	SANI CLAMP, 3"	2
4.	KE02291	COMPLETE ACTUATOR AND DISCHARGE VALVE ASSEMBLY <i>INCLUDES PARTS 5. - 13.</i>	1
5.	FA05002-51	BUNA-N O-RING	1
6.	KE55249	REPLACEABLE S.S. PLUNGER HEAD	1
8.	KE55251	1/8 NPT S.S. HYDRAULIC CLOSE NIPPLE	2
9.	KE55257	MALE S.S. QUICK DISCONNECT	1
10.	KE55253	AIR OPERATED CYLINDER	1
11.	KE55262	FEMALE S.S. QUICK DISCONNECT	1
12.	FA05002-53	BUNA-N O-RING	2
13.	KE003700	DISCHARGE TEE ASSEMBLY	1

PNEUMATICS

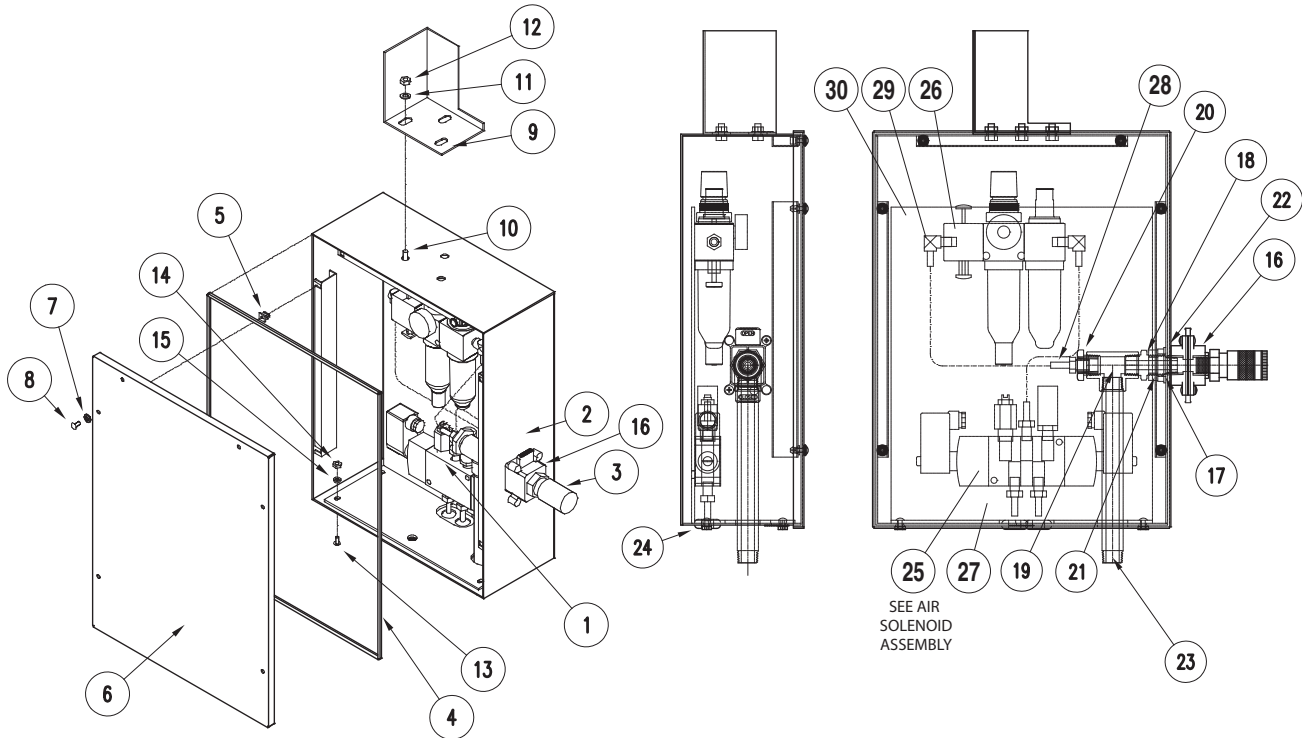

ITEM NO.	PART NO.	DESCRIPTION	QTY.
1	KE02296	PNEUMATIC ASSEMBLY, INCLUDES ITEMS 25 - 31	1
2	KE02299	PNEUMATIC BOX WELDMENT	1
3	F105166	QUICK CONNECTOR, 3/8	1
4	KE54846-8	GASKET, U-CHANNEL	1
5	FA95074	NYLON ANCHOR NUT, #8 THREADED HOLE	6
6	KE55241	COVER, PNEUMATIC BOX	1
7	KE55242	SEALING WASHER, #8	6
8	FA11091	S.S. SCREW, #8-32 X 3/8, BINDING HD	6
9	KE55243	MOUNTING BRACKET, PNEUMATIC BOX	1
10	FA11255	S.S. HEX HEAD SCREW, 1/4-20 X 3/8	3
11	FA30034	1/4 FLAT WASHER	3
12	FA21008	S.S. NUT, 1/4-20	3
13	FA11134	S.S. SCREW #10-24 X 3/8, PAN HEAD	4
14	FA21006	S.S. NUT, #10-24	4
15	FA30000	WASHER, #10	4
16	KE54280	SLIDE VALVE	1
17	FA30512	SPACER WASHER	1
18	KE52931	AIR FITTING.	1
19	KE600814-1	TEE 1/2 NPT, BRASS, FIP X FIP X FIP	1
20	FI05047	BUSHING, REDUCER, 1/2 NPT X 1/4 NPT	1
21	KE52697	NUT, 1/2 NPT BRASS	1
22	FA32500	LOCKWASHER, INTERNAL TOOTH, 7/8	1
23	F100595-16	NIPPLE, 1/2 NPT BRASS	1
24	KE50555-3	GROMMET	2
25.	KE02292	AIR SOLENOID ASSEMBLY (SEE SOLENOID ASSEMBLY DRAWING)	1
26.	KE55238	FILTER - REGULATOR - LUBRICATOR BLOCK	1
27.	KE55239	MOUNTING PLATE, PNEUMATIC ASSEMBLY	1
28.	FI05317-2	HOSE BARB, MALE, 1/4 NPT X 1/4 HOSE	1
29.	FI05167	HOSE BARB, 90° ELBOW	2
30.	FI05220-1	GEAR CLAMP, 1/4 HOSE	4
31.	KE53217-6	PNEUMATIC HOSE, 1/4 I.D. X ~12 LONG	2

AIR SOLENOID ASSEMBLY

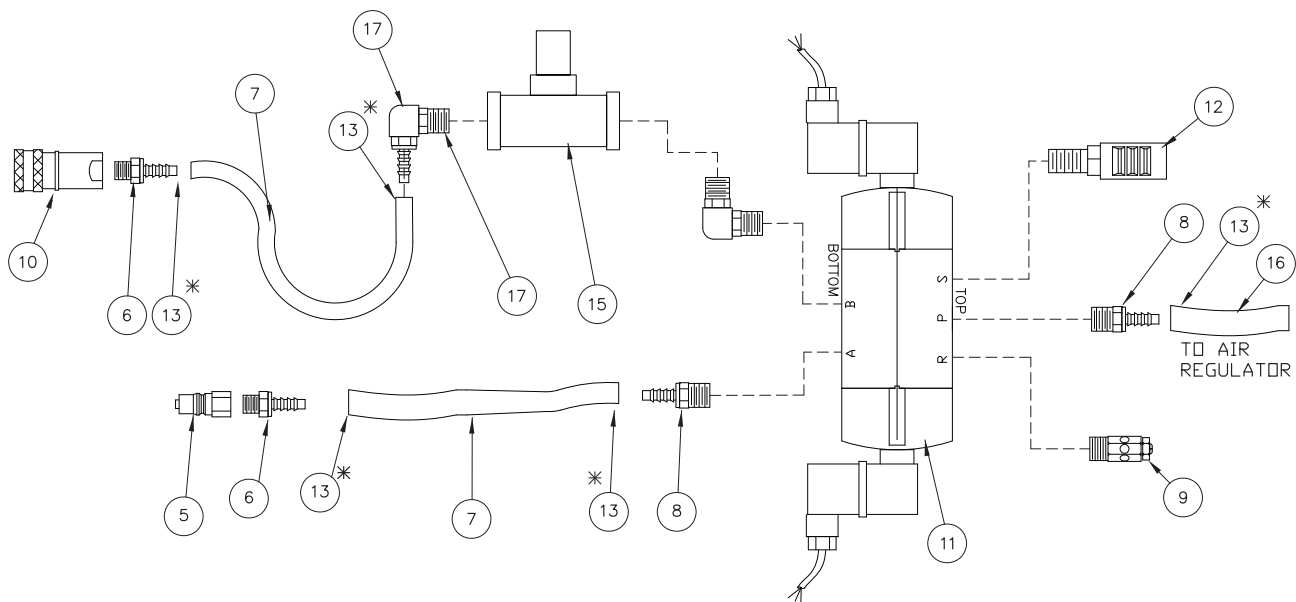

ITEM NO.	PART NO.	DESCRIPTION	QTY.
5	KE55257	MALE QUICK PLUG	1
6	FI05317-1	HOSE BARB 1/8" NPT MALE TO 1/4" HOSE	2
7	KE55259-1	1/4" ID X 6 FT. LONG HOSE 250 #W,P,	2
8	FI05317-2	HOSE BARB 1/4" NPT MALE TO 1/4" HOSE	1
9	KE55261-1	SPEED EXHAUST MUFFLER 1/8"	1
10	KE55262	FEMALE QUICK PLUG	1
11	KE55263-1	5 WAY AIR SOLENOID VALVE	1
12	KE55264-1	STANDARD 1/8" MUFFLER	1
13	FI05220-1	GEAR CLAMP FOR 1/4 I.D. HOSE (NOT SHOWN)	5
14	FI05030-2	90° 1/4 ELBOW, MALE PIPE THREAD	1
15	KE55305	1/4" FLOW CONTROL	1
16	KE55259-2	1/4" ID X 3 FT. LONG HOSE 250 #W,P,	1
17	FI05318	90° ELBOW HOSE BARB, 1/4 HOSE I.D. X 1/4 PIPE, BRASS	2

GEARMOTOR - ELECTRICAL ASSEMBLY

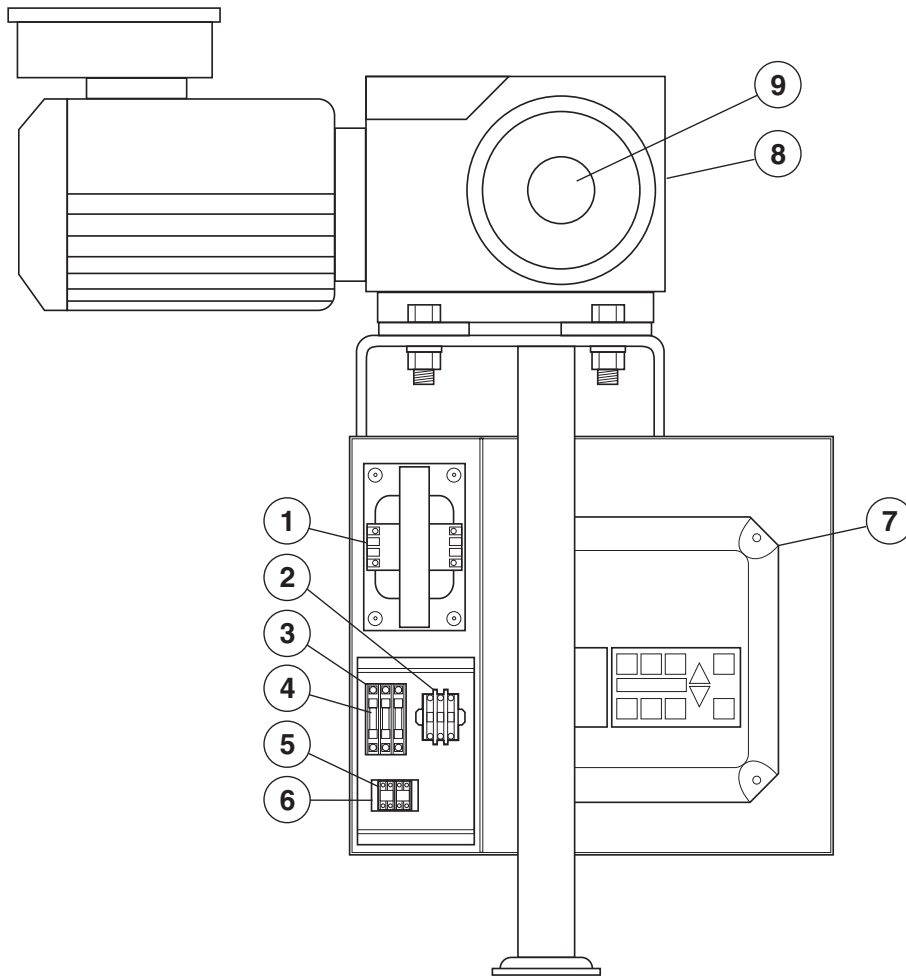

ITEM NO.	PART NO.	DESCRIPTION	QTY.
1.	KE53838-2	TRANSFORMER, 200-240V/440-480V	1
2.	KE603902-2	CONTACTOR	1
3.	KE51139-1	FUSE HOLDER	3
4.	KE52936-18	15A FUSE, KLKR	3
5.	PR50003	TERMINAL BLOCK	
6.	PR50005	TERMINAL BLOCK BRACKET	1
7.	KE54528-1	A.C. INVERTER, 230V	1
	KE54528-2	A.C. INVERTER, 460V	1
8.	KE54527-1	GEAR MOTOR, 208V/60HZ	1
	KE54527-4	GEAR MOTOR, 480V/60HZ	1
9.	KE54594	DRIVE SHAFT	1

COMPONENT PLATE ASSEMBLY - POWER TILT

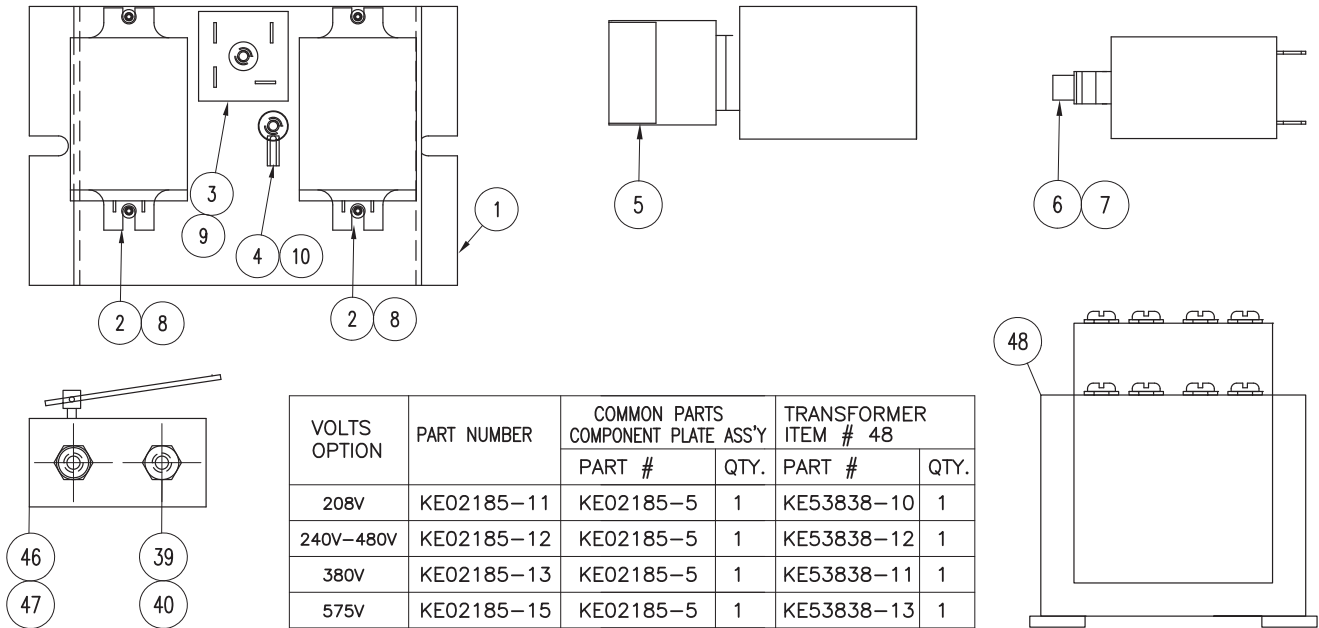

ITEM NO.	PART NO.	DESCRIPTION	QTY.
-----------------	-----------------	--------------------	-------------

COMMON PARTS

1	KE50343-16	COMPONENT PLATE	.1
2	KE50753-10	RELAY, 10A/120V	.2
3	KE50581	BRIDGE RECTIFIER	.1
4	KE50473	GROUND LUG	.1
5	KE003209-11	SWITCH, POWER TILT	.1
6	KE50579-1	CIRCUIT BREAKER, 1.5A	.1
	KE50579-3	CIRCUIT BREAKER, 3A, USED AFTER JULY 2010	.1
7	KE50580	WATER RESISTANT BOOT	.1
8	FA11051	6-32 X 3/16 PAN PHIL S.S.	.4
9	FA11091	8-32 X 3/8 PAN PHIL S.S.	.1
10	FA11089	8-32 X 1/4 PAN PHIL S.S.	.1
11*	NPN00158	FULLY INSULATED NYLON MALPLER	.3
12*	KE52289-3	#8 SPADE	.4
13*	NPN00143	TERMINAL, FLAG SLIP-ON	.12
14*	NPN00158-1	WIRE COUPLER	.2
15*	KE52295	TERMINAL, FLAG SLIP-ON	.4
16*	NPN00009	WIRE JOINT PIGTAIL	.1
17*	NPN00103	FULL INSULATED PUSH ON TERMINAL	.3
18*	NPN00020	CABLE TIE HOLDER	.5
19*	K E51627	CABLE TIE 5 1/2"	.7
20*	RB01551	BLACK SLEEVING, SIZE 2, HO, L 136"	.1
39*	FA20002	HEX NUT 6-32	.2
40	FA11060	SCREW 6-32 X 1	.2
46	KE51007	MICRO SWITCH, HONEYWELL	.2
47	KE50498	MICRO SWITCH INSULATION	.2
48	(SEE CHART)	TRANSFORMER	.1

* ITEMS NOT SHOWN

**ASSEMBLY
DRAWING,
TILTING UNITS**

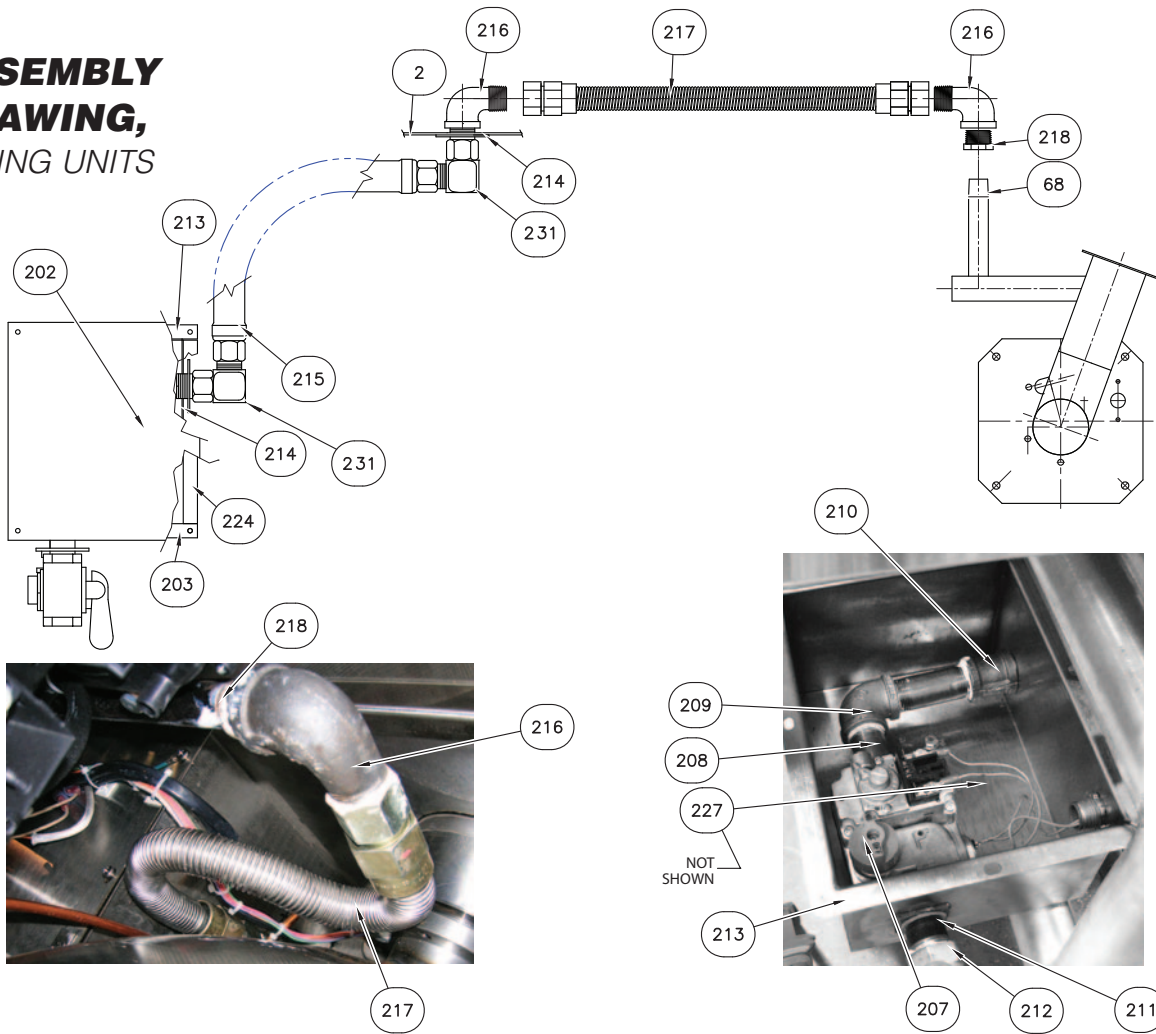

ITEM NO.	PART NO.	DESCRIPTION	QTY
202	KE602791	COVER - GAS VALVE BOX,	1
203	KE53599-18	GASKET	2
207	KE02053	GAS VALVE	1
208	N0640B3	SPECIAL NIPPLE	2
209	FI00063	ELBOW 90 DEG. BRASS	1
210	FI00267	3/4" COUPLING, BRASS	1
211	N0640C1-5	3/4" X 1 1/2 NIPPLE, BLK. IRON	1
213	KE602790	GAS VALVE BOX	1
214	KE54606	GAS VALVE LOCK WASHER	2
215	SK2472703	GAS CONNECTOR HOSE (60/80/100 GAL)	1
216	FI00134	3/4" ELBOW, 90° STREET	2
217	KE602899	GAS CONNECTOR HOSE	1
218	FI05231	BUSHING, REDUCER, 3/4"-1/2" NPT	1
221	KE51900	3/8 LIQUID TITE CONNECTOR, 90°	1
224	KE53599-19	GASKET	2
225	KE602902	BRACKET CONDUIT CONNECTOR	1
226	FA30088	WASHER	1
227	KE52000-1	MESH	1
228	KE602987-1	WASHER GEAR SIDE	1
230	SK2472702	3/4" SWIVEL GAS FITTING	2
231	SK2472702	3/4" ELBOW, MALE TO FEMALE	2

SCRAPER BLADES

ITEM NO.	PART NO.	DESCRIPTION	QTY.
1.	KE54602-1	SCRAPER BLADE	as required
2.	KE54608	SPRING	as required
3.	KE01976	SPRING REMOVAL TOOL	1
COMPLETE AGITATOR ASSEMBLY			
(NOT SHOWN)	KE02286-1	60 GALLON	1
	KE02286-2	80 GALLON	1
	KE02286-3	100 GALLON	1

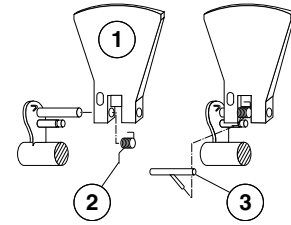

AGITATOR SEAL ASSEMBLY

ITEM NO.	PART NO.	DESCRIPTION	QTY.
8.	KE54592	SEAL RETAINER PLATE	1
9.	FA05002-48	"O" RING	1
10.	KE55458	SEAL	1
11.	KE55457	SST WAVE WASHER	1
12.	KE55456	SILICONE FILLED SEAL	1
13.	KE55455	RETAINER FOR LIP SEALS	1
14.	FA11509-5	BOLT, HEX HEAD, 3/8 16 x 2 1/2	2
15.	FA31031	WASHER, 3/8 18-8	2
16.	KE600583	GREASE NIPPLE, 1/8 NPT	2

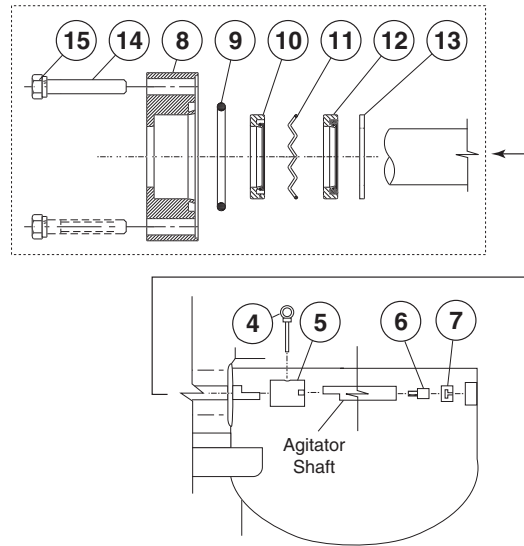

AGITATOR CONTROLS

ITEM NO.	PART NO.	DESCRIPTION	QTY.
1.	KE53193	BUTTON, EMERGENCY STOP	1
2.	KE54530-1	HEAD CAP, GREEN	1
	KE603106	LED LAMP	1
3.	KE54529	SWITCH, AGITATOR POWER	1
4.	KE54532	SWITCH, SPEED CONTROL	1
5.	KE95483-1	LABEL	1

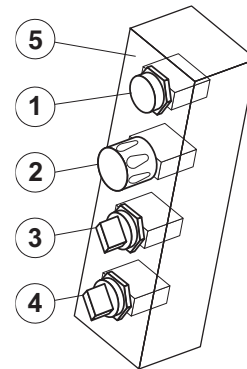

TEMPERATURE SENSOR

ITEM NO.	PART NO.	DESCRIPTION	QTY.
4.	KE54924-1	TEMPERATURE SENSOR ASSEMBLY	1
		(INCLUDES 5, 6, 7)	
5.	KE54924-2	SENSOR MAIN BODY	1
6.	KE54924-3	TANK MOUNTING ADAPTOR	1
7.	FA05002-23	SENSOR O-RING	1

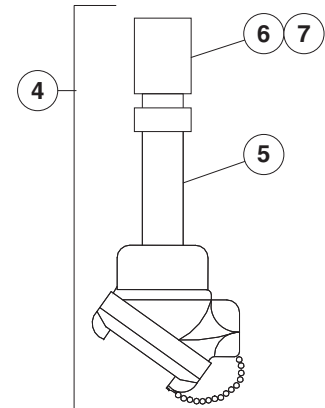

GEAR BOX ASSEMBLY

OPTIONS BUILT	
PART#	DESCRIPTION
KE003775-1	A BASIC GEARBOX
KE003775-2	A PARTS PNEUMATICS FOR FPA3 OPTION
KE003775-3	A PARTS FOR WATER METER OPTION
KE003775-4	A AGISTRO8 SWITCHES
KE003775-5	A COMPONENTS FOR HA-5G/DCB REMOTE PANEL OPTION
KE003775-6	A PARTS FOR WITHOUT WATER METER OPTION

KE003775-1 BASIC GEARBOX	
1	KE000852-1 GEARBOX CONSOLE WELDMENT
2	REF KE02185 COMPONENT PLATE, POWER TILT, KETTLE
3	KE601342-1 GEAR MOTOR
4	KE602802-1 RIGID COUPLING
5	KE602802-2 SPLIT TAPER BUSHING, 1 3/4 BORE
6	KE95481-4 LABEL, GEARBOX
7	SKA274501 LIMIT SWITCH
8	FA10140 SCREW #6-32UNC X 1 1/4 LG.
9	KE602798-1 LIMIT SWITCH BRACKET
10	KE602798-1 LIMIT SWITCH BRACKET
11	FAT1386 HEX BOLT S.S. 3/8-16UNC X 1 1/2 LG.
12	FA21026 HEX NUT S.S. 3/8-16UNC
13	FA31031 SPLIT LOCK WASHER S.S. 3/8
14	KE53599-12 GASKET
15	KE53599-20 GASKET
16	FA30505-11 MACHINE SCREW 10-32 X 3/8, S.S.
17	KE003209-11 SWITCH, ON/OFF/ON (MOM/MAINT/MOM)
18	KE602802-3 SPLIT TAPER BUSHING, 2 1/2 BORE
19	KE50473 GROUND LUG
20	FA32022 EXTERNAL TOOTH LOCK WASHER #10
21	FA21006 HEX MACHINE SCREW NUT UNC. 10-24, S.S.
22	FA21008 HEX NUT SCREW NUT 1/4-20UNC, S.S.
23	FA31029 LOCK WASHER 1/4, S.S.
24	FA30505-1 FLAT WASHER 1/4, S.S.
25	KE53595 SQUARE KEY 3/8
26	KE50579-4 CIRCUIT BREAKER (2.5 Amp)
27	FA90074 NYLON ANCHOR
28	KE601135 COVER, GEARBOX
29	KE600931-1 SHAFT, GEAR REDUCER
30	KE603884-2 SPECIAL KEY
31	FA30505-10 WASHER, S.S.
32	FA95101 HEX CAP SCREW, 5/8-11 X
33	FA30076 #10 SAE FLAT WASHER
34	FA2804-1 #6-32 "K" LOCK NUT ZINC
35	KE50580 WATER RESISTANT BOOT
36	KE95481-7 LABEL, GEARBOX

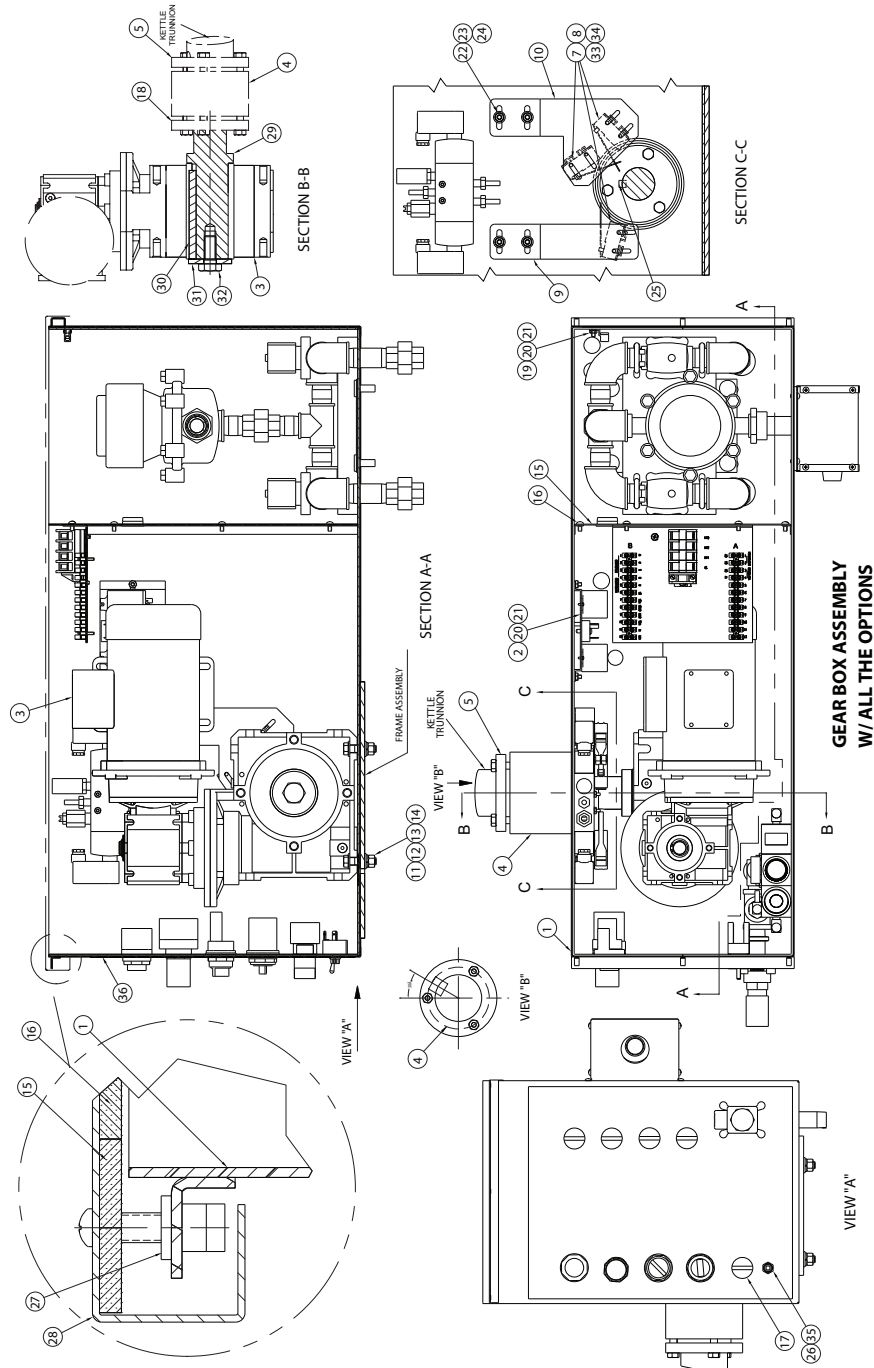

GEAR BOX ASSEMBLY

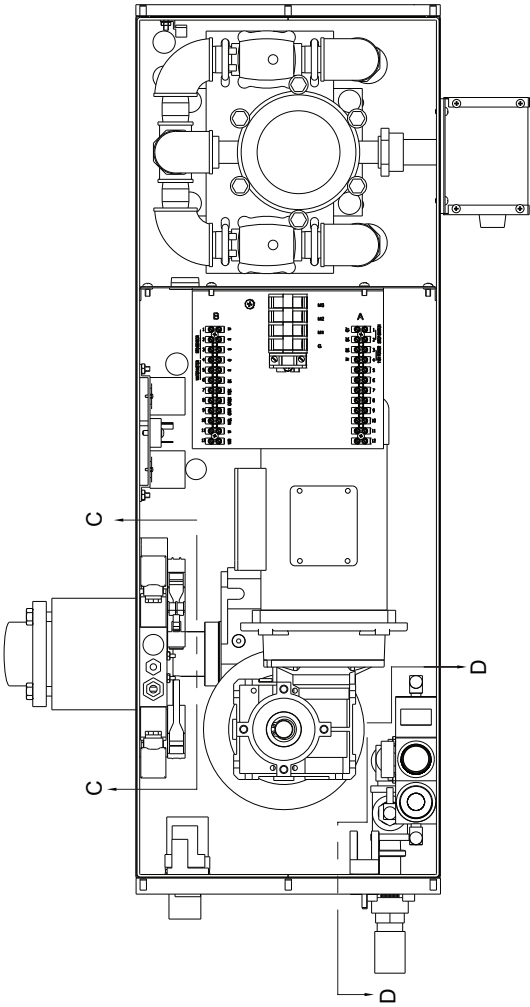

KE003775-2 PNEUMATICS FOR FPVA3

60	KE601603	QUICK CONNECT	1
61	KE601601	SLIDE VALVE	1
62	FA30512	SPACER WASHER	1
63	FA32500	TOOTH LOCK WASHER 7/8 DIA.	1
64	KE52697	NUT 1/2 NPS BRASS	1
65	KE601602	AIR FITTING	1
66	KE600814-1	TEE 1/2 NPT	1
67	F100351	BUSHING 1/2 MIP X 1/4 FIP	1
68	F105318	HOSE BARB 90 DEGREE ELBOW	3
69	KE600812-1	90 DEGREE STREET ELBOW 1/2 NPT	1
70	KE54353	WASHER 7/8 ID X 2 OD	1
71	N044084-5	NIPPLE 1/2 NPT X 4 1/2 LONG	1
72	KE02369	FILTER-REGULATOR-LUBRICATOR ASSY	1
73	KE02292	AIR SOLENOID ASSEMBLY	1
74	F105220-1	GEAR CLAMP	4
75	FA21002	HEX NUT, 6-32, S.S.	4
76	KE532177	PNEUMATIC HOSE, 1/4 ID X 31 L	1
77	KE532176	PNEUMATIC HOSE, 1/4 ID X 12 1/2	1
78	FA32004	TOOTH LOCK WASHER, #6, ZINC PLATED	4
79	KE50555-3	GROMMET	2
80	KE003209-9	SWITCH ON/OFF ON(MAINT/MAINT/MOM)	1

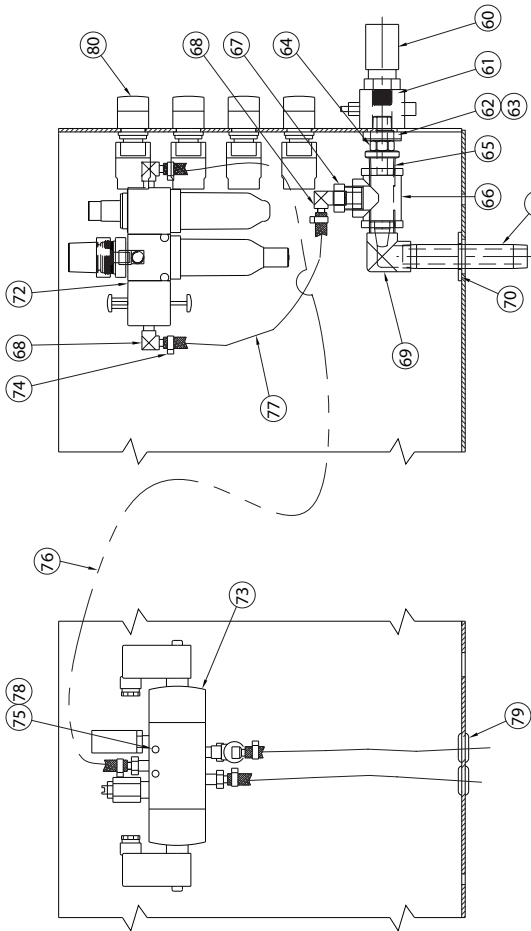

SECTION C-C
SHOWING ONLY THE PNEUMATICS ASSEMBLY.

SECTION D-D

GEAR BOX ASSEMBLY

KE003775-3 DIGITAL WATER METER			
ITEM	PART#	DESCRIPTION	QTY.
111	KES3380	SIDE BOX, FILLER HOSE	1
112	KES5351-2	COVER, FILLER BOX	1
113	KES5351-1	COVER, FILLER BOX	1
114	FA11091	MACHINE SCREW, 8-32 X 3/8" 1/2 S.S.	12
115	KES5231-1	1/2 SINGLE WALL POT FILLER	1
116	REF. KE02289	PLUMBING ASSEMBLY, WATER METER	1
117	KES4833-4	SNAP-IN BUSHING, 1.093 DIA	1
118	KE003209-6	** SWITCH-OFF (SPRING RETURN)	1
119	KE003209-2	** SWITCH-ON (ON MAINTAINED)	1
120	KES3257	** DIGITAL COUNTER	1
121	KE003209-7	** SWITCH-OFF (ON (LEFT & RIGHT MOM))	1
122	KES2936-3	* FUSE, 1 AMP	1
123	KES1139	* FUSE HOLDER	1
124	KES0343-6	* COMPONENT PLATE	1
125	KE0753-10*	RELAY (N/A WITH HA-SG/DG REMOTE PANEL)	2
126	FA21026	HEX NUT S.S. 3/8-16 UNC	4
127	FA31031	SPLIT LOCK WASHER S.S. 3/8	4
128	FA30505-11	FLAT WASHER S.S. 3/8	4
129	KE600964-1	PARTITION PLATE	1
130	FA11145	MACHINE SCREW 10-32 X 3/8, S.S.	6
KE003775-4 AGITATOR SWITCHES			
151	KES3193	EMERGENCY STOP	1
152	KES4530**	AGITATOR START BUTTON	1
153	KES4529**	AGITATOR POWER SWITCH	1
154	KES4532**	SPEED CONTROL SWITCH	1
155	KE603106**	LED LAMP	1
156	KES4530-1	GREEN PUSH HEAD CAP	1
KE003775-5 WITHOUT WATER METER			
171	FA11091	MACHINE SCREW 8-32 X 3/8 S.S.	4
172	KE601213	BOTTOM COVER	1
173	REG03731	COVER PLATE	1
KE003775-6 FOR HA-SG/DG REMOTE PANEL			
191	KE603608-1	COMPONENT ASSEMBLY	1
192	FA11525-1	SEMS HEAD SCREW #10-32 X 3/8	2

NOTES:

- (*) PARTS NOT SHOWN ON DWG.
- (**) THESE COMPONENTS ARE NORMALLY PART OF GEARBOX, BUT WITH REMOTE CONTROL PANEL OPTION THEY ARE INCLUDED IN KE02310 AND EXCLUDED FROM GEARBOX.
- (****) DIGITAL COUNTER IS NORMALLY PART OF REMOTE CONTROL PANEL, TCR OR DTCI CONSOLES.

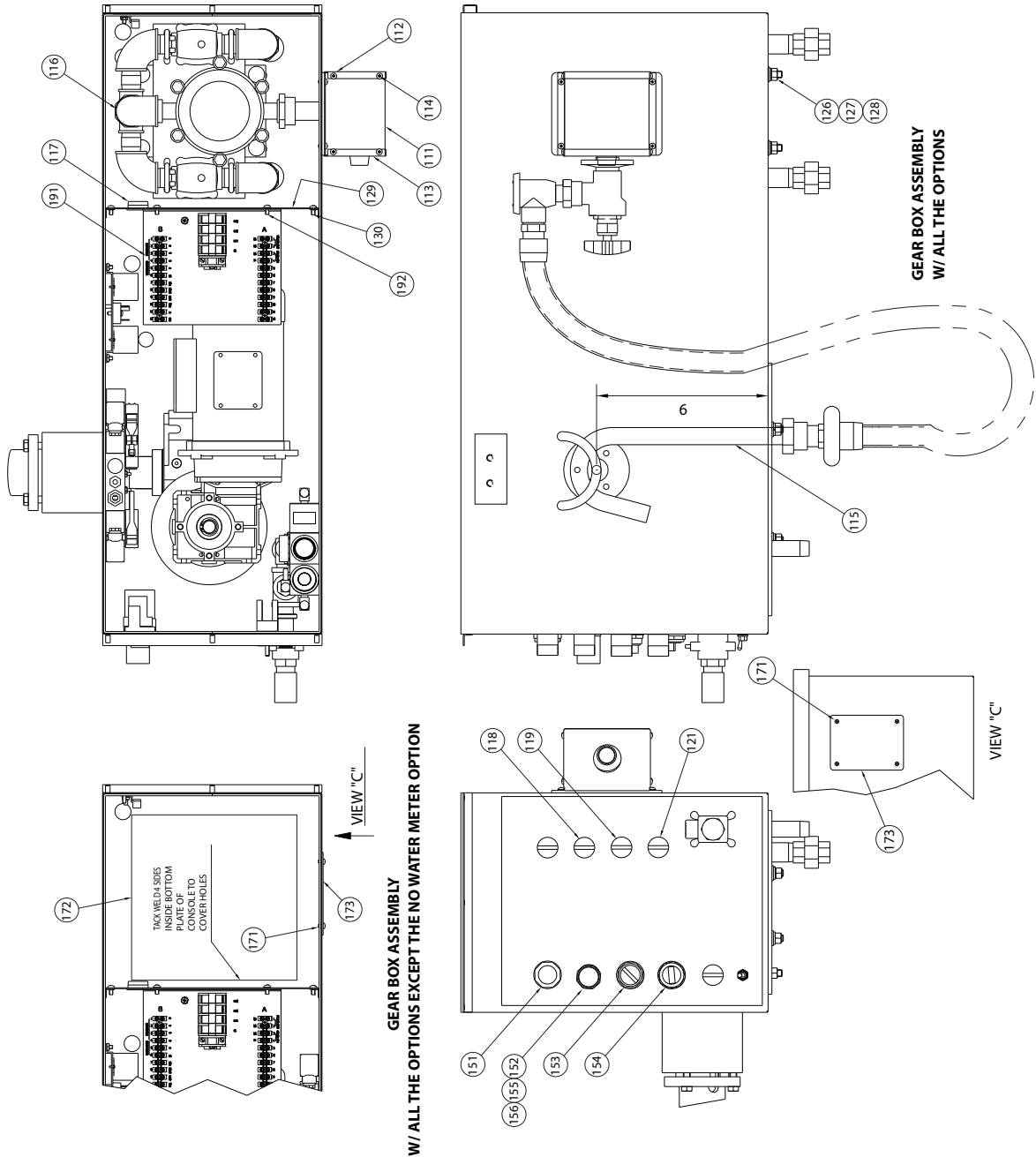

OPTIONAL REMOTE CONTROL BOX

For front panel control switches see -
GEARBOX ASSEMBLY & CONTROL BOX ASSEMBLY

NOTE: Dual control panel shown.
Single panel uses 1/2 the parts.

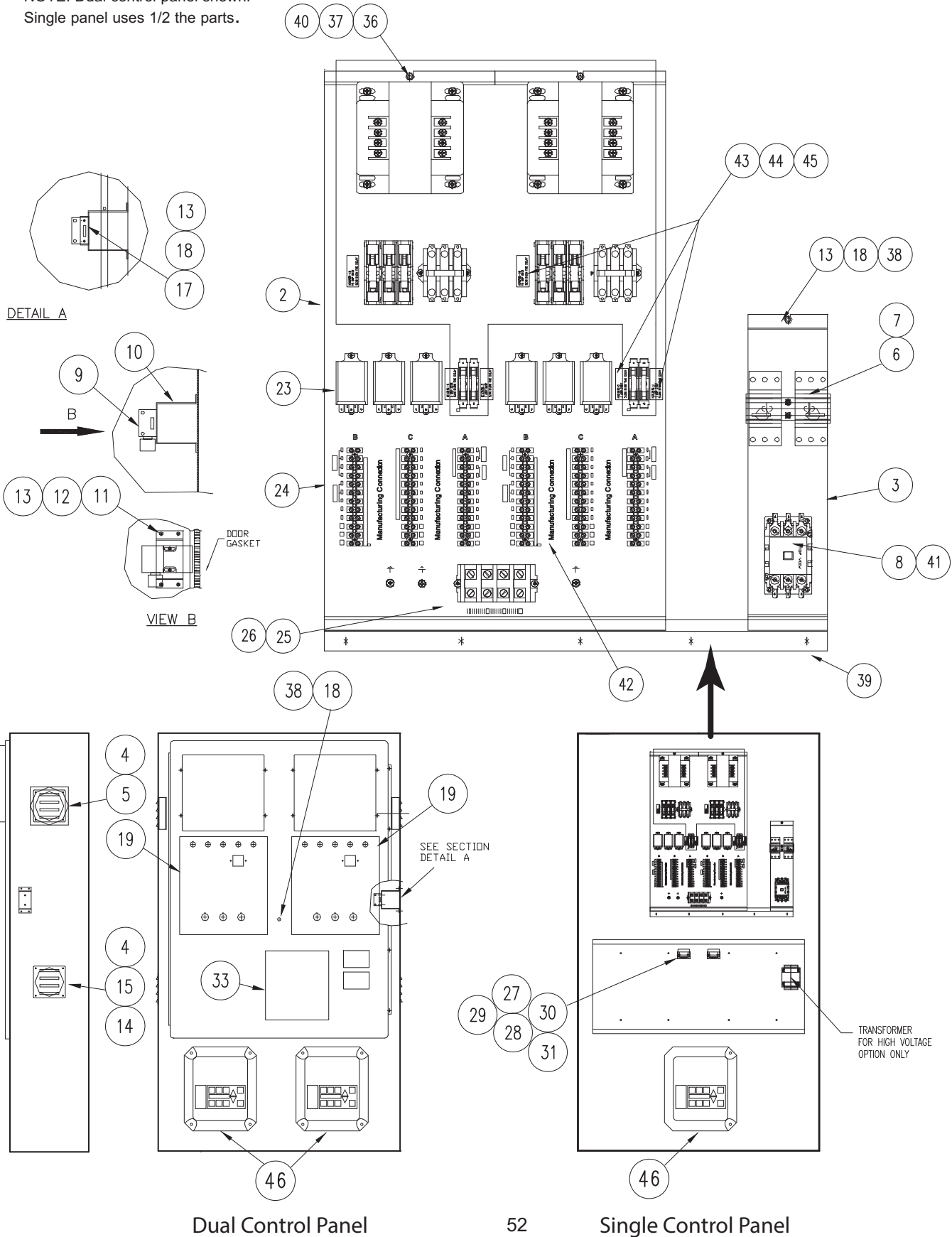

OPTIONAL REMOTE CONTROL BOX

ITEM ON.	PART NO.	DESCRIPTION	QTY.
			Single / Duo
2	KE55284-1	COMPONENT MNTG PLATE, DUAL PANEL	- / 1
	KE55284-2	COMPONENT MNTG PLATE, SINGLE PANEL	1 / -
3	KE55286-2	MOUNTING BRACKET, INCOMING	1 / 1
4	KE54860	FAN	2 / 2
5	KE55283	VENT COVER PLATE	4 / 4
6	KE55288-2	MOUNTING RAIL	1 / 1
7	KE55298	MOTOR PROTECTOR SWITCH	1 / 2
		CONTACTOR FOR 208-240 VAC SUPPLY	
8	KE603902-4	CONTACTOR, 240 VAC, 50 AMP	- / 1
	KE603902-2	CONTACTOR, 240 VAC, 35 AMP	1 / -
		CONTACTOR FOR 460 VAC SUPPLY	
41	KE603902-7	CONTACTOR, 120 VAC, 40 AMP	- / 1
	KE603902-1	CONTACTOR, 120 VAC, 35 AMP	1 / -
9	KE55297	SAFETY INTERLOCK SWITCH	1 / 1
10	KE55285	MOUNTING BRACKET, DOOR INTERLOCK SW	1 / 1
11	FA40000-15	WELD STUD, #10-32 X 1/2, S.S.	4 / 4
12	FA21007	HEX NUT, #10-32, S.S.	4 / 4
13	FA32006	S.S. TOOTH LOCK WASHER, #10	7 / 7
14	FA11091	S.S. #8-32 X 3/8 SCREW	16 / 16
15	FA21004	S.S. NUT #8-32	16 / 16
17	FA40000-14	S.S. #10-24 X 3/4 WELD STUD	2 / 2
18	FA21006	S.S. HEX NUT #10-24	4 / 4
19	KE55271	LABEL, REMOTE CONTROL PANEL	1 / 2
23	KE50753-10	RELAY, 120 V (HOT/COLD WATER, BYPASS)	3 / 6
24	KE603615	TERMINAL BLOCK, 12 SECTIONS	3 / 6
25	KE50377	TERMINAL BLOCK	4 / 4
26	KE50376	TERMINAL BLOCK END	1 / 1
27	KE50374	TERMINAL BLOCK MOUNTING BRACKET	1 / 2
28	SK50055-1	TERMINAL BLOCK	4 / 8
29	SK50054-1	TERMINAL BLOCK END	1 / 2
30	KE54761-2	TERMINAL BLOCK MOUNTING RAIL	1 / 2
31	SK50054-2	TERMINAL BLOCK END	2 / 4
32	KE54761	TERMINAL BLOCK MOUNTING RAIL	1 / 2
33	KE90425-1	WIRING DIAG, DUAL REM. PANEL, 200/240V	- / 1
	KE90425-2	WIRING DIAG, SINGLE REM. PNL, 200/240V	1 / -
	KE90425-4	WIRING DIAG, DUAL REM. PANEL, 460/480V	- / 1
	KE90425-5	WIRING DIAG, SINGLE REM. PNL, 460/480V	1 / -
37	FA21008	HEX NUT, 1/4-20 SS	1 / 2
39	KE53450	JUGGLED STRIP (23 1/2 LG.), FOR DUAL	- / 1
	KE53450-1	JUGGLED STRIP (CUT TO SUIT AT ASSY), FOR SINGLE	1 / -
40	FA31029	SS SPLIT LOCKWASHER 1/40	1 / 2
42	KE603617	LABEL, TERMINAL ID SINGLE	1 / -
	KE603635	LABEL (DUAL), TERMIAL ID	- / 1
43	KE52936-3	FUSE, 1 AMP	1 / 2
44	KE52936-5	FUSE, 5 AMP	1 / 2
45	KE52936-18	FUSE, 15 AMP	1 / 2
46.	KE54528-1	A.C. INVERTER, 230V	1 / 2
	KE54528-2	A.C. INVERTER, 460V	1 / 2

TEMPERATURE CHART RECORDER BOX ASSEMBLY

MKDL-T / TMKDL-T / MKGL-T / HA-MKGL

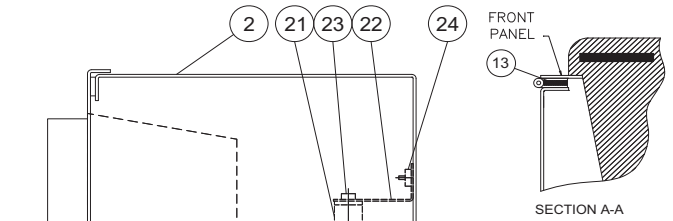
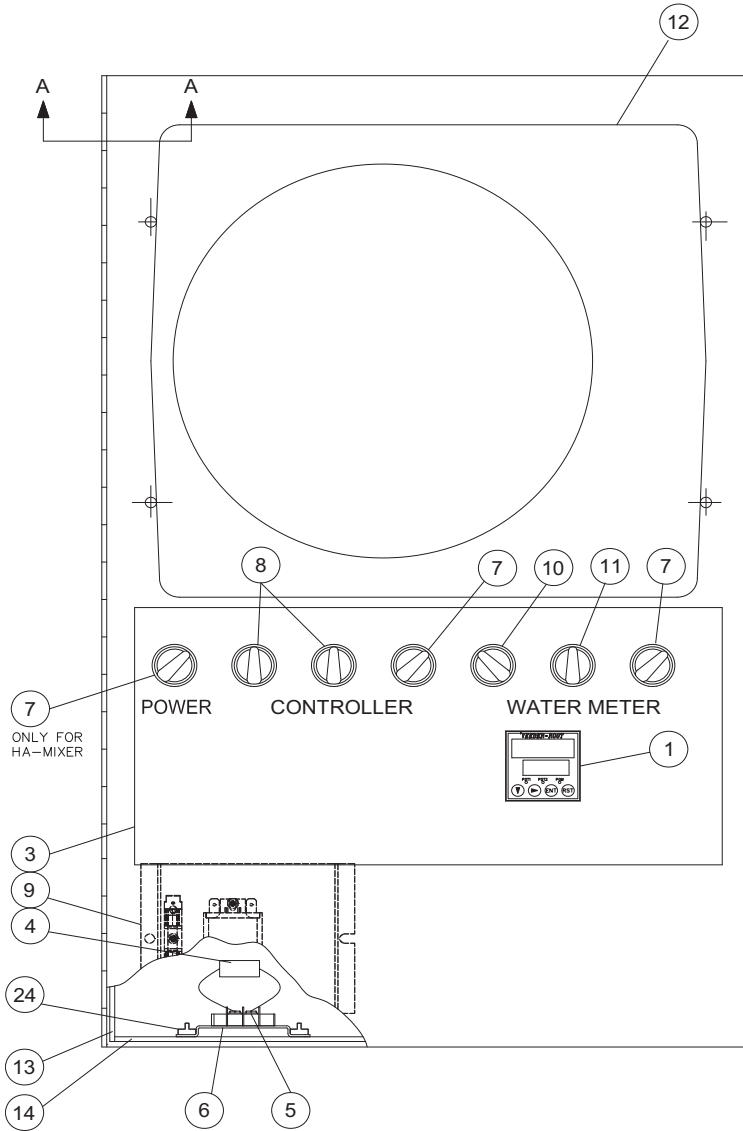

ITEM	PART #	DESCRIPTION	COMMON PARTS			
			HA-MIXER	VERTICAL MIXER	SINGLE HEAT-COOL	TWIN HEAT-COOL
1	KE53257	DIGITAL COUNTER				1
2	KE01354	TCR BOX WELDMENT	1	1		
3	KE95438	LABEL	1	1		
4	KE01820	AMBIENT HEATER ASSEMBLY	1	1		
5	SK50370-1	TERMINAL BLOCK; 2 SECTIONS	1	1		
6	KE54402	MOUNTING BRACKET	1	1		
7	KE003209-1	SWITCH ON/OFF-MAINTAINED	1	1	1	1
8	KE003209-3	SWITCH ON/OFF/ON-MAINT. (HEAT/COOL CONTROL)			1	2
9	REF.KE003736	COMPONENT PLATE ASSEMBLY	1	1		
10	KE003209-6	SWITCH ON/OFF-SPR. RETURN MOMENT.				1
11	KE003209-7	SWITCH ON/OFF-SPR. RETURN MOMENT. L/R				1
12	KE53136-1	CHART RECORDER (TCR-DTCI)/TEMPERATURE CONTROLLER	1	1		
13	KE53131	GASKET STRIP 1/2 X 1/8 X 24 1/4	2	2		
14	KE53132	GASKET STRIP 1/2 X 1/8 X 15 3/4	2	2		
18*	NPN00020	CA TIE HOLDER; ADHESIVE BACK	25	25		
19*	SK50370-2	45 DEG TABS CURTIS; TERMINAL BLOCK	4	4		
20*	SK50370-3	90 DEG TABS CURTIS; TERMINAL BLOCK	4	4		
21	KE52710	THERMOSTAT	1	1		
22	KE603924	BRACKET FOR THERMOSTAT	1	1		
23	FA20504-1	"K" LOCKNUT ZINC	1	1		
24	FA21006	10-24 HEXAGON NUTS	3	3		

* NOTE: PARTS NOT SHOWN ON DWG.

KE003730A

PART NUMBER	SWITCH	SWITCH	SWITCH	SWITCH	SWITCH	PUSH	LATCH	CONTACT	CONTACT
# OF POSTITIONS	2 maintained	3 maintained	2 spring return from right	3 spring return from both sides	3 spring return from right	flush		normally closed	normally open
ASSEMBLY #									
KE003209-1	1						1		1
KE003209-2	1						1	1	1
KE003209-3		1					1		2
KE003209-4		1					1		1
KE003209-5		1					1		3
KE003209-6			1				1	1	
KE003209-7				1			1		3
KE003209-8				1			1		2
KE003209-9					1		1		2
KE003209-10						1	1	1	1
KE003209-11				1			1		4

WATER METER ASSEMBLY

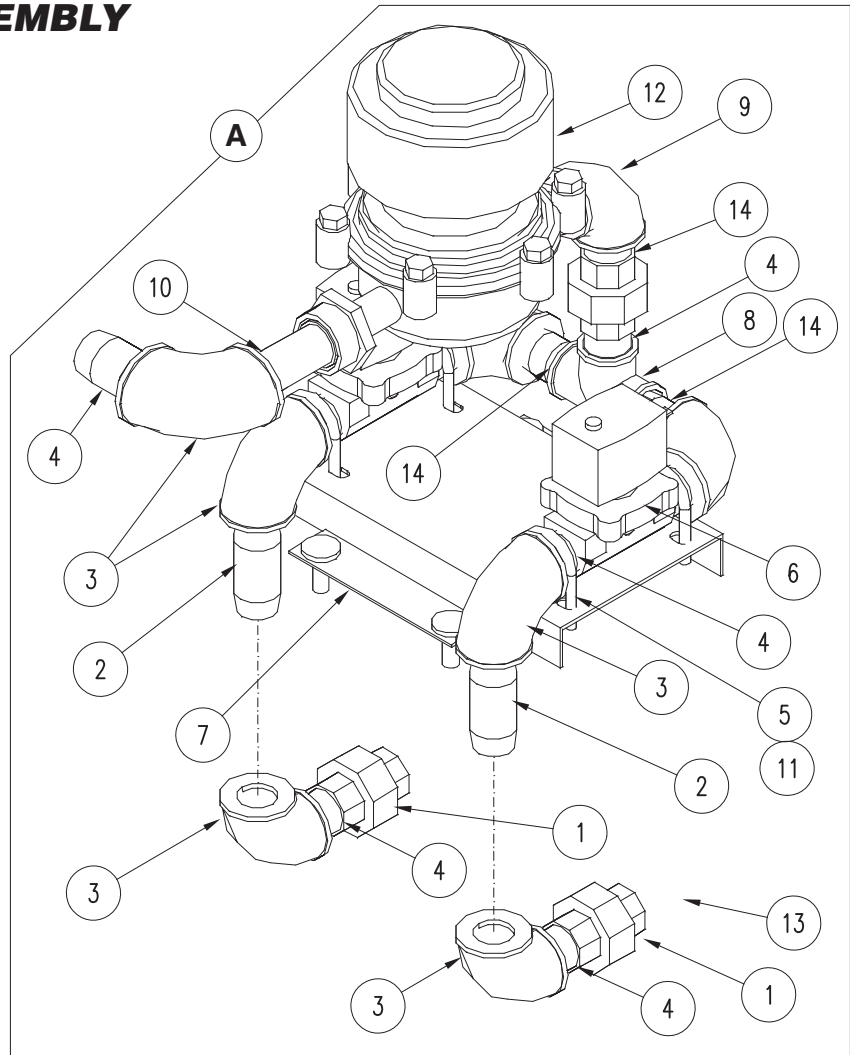

ITEM ON.	PART NO.	DESCRIPTION	QTY.
A	KE02289-1	COMPLETE ASSEMBLY; GALLON METER, HAMKGL-T	
	KE02289-2	COMPLETE ASSEMBLY; LITRE METER, HAMKGL-T	
	KE02289-3	COMPLETE ASSEMBLY; GALLON METER, HAMKGL	
	KE02289-4	COMPLETE ASSEMBLY; LITRE METER, HAMKGL	
1	FI00096	3/4 BRASS UNION	.3
2	FI00629-2	3/4 NPT X 2 1/2 BRASS NIPPLE	.2
3	FI00063	3/4 NPT BRASS ELBOW	.7/5
4	FI00629-36	3/4 NPT CLOSE BRASS NIPPLE	.10/6
5	FA95092-2	U-BOLT, 1/4-20	.4
6	KE54834-4	SOLENOID VALVE	.2
7	KE02290	MOUNTING PLATE ASSY, HOT COLD WM	.1
8	FI00179	3/4 NPT BRASS FEMALE TEE	.1
9	FI00365	3/4 X 1 REDUCING BRASS ELBOW	.1
10	FI05153	ADAPTOR NIPPLE & GASKET	.1
11	FA21008	S.S. NUT 1/4-20	.8
12	KE54336	GALLON METER, HOT WATER	
	KE52002-1	LITRE METER, HOT WATER	
13	KE51250-2	3/4 BRASS CHECK VALVE	.2
14	FI00629-1	3/4 NPT X 2 BRASS NIPLE	.3

WIRE TERMINATION ASSEMBLY

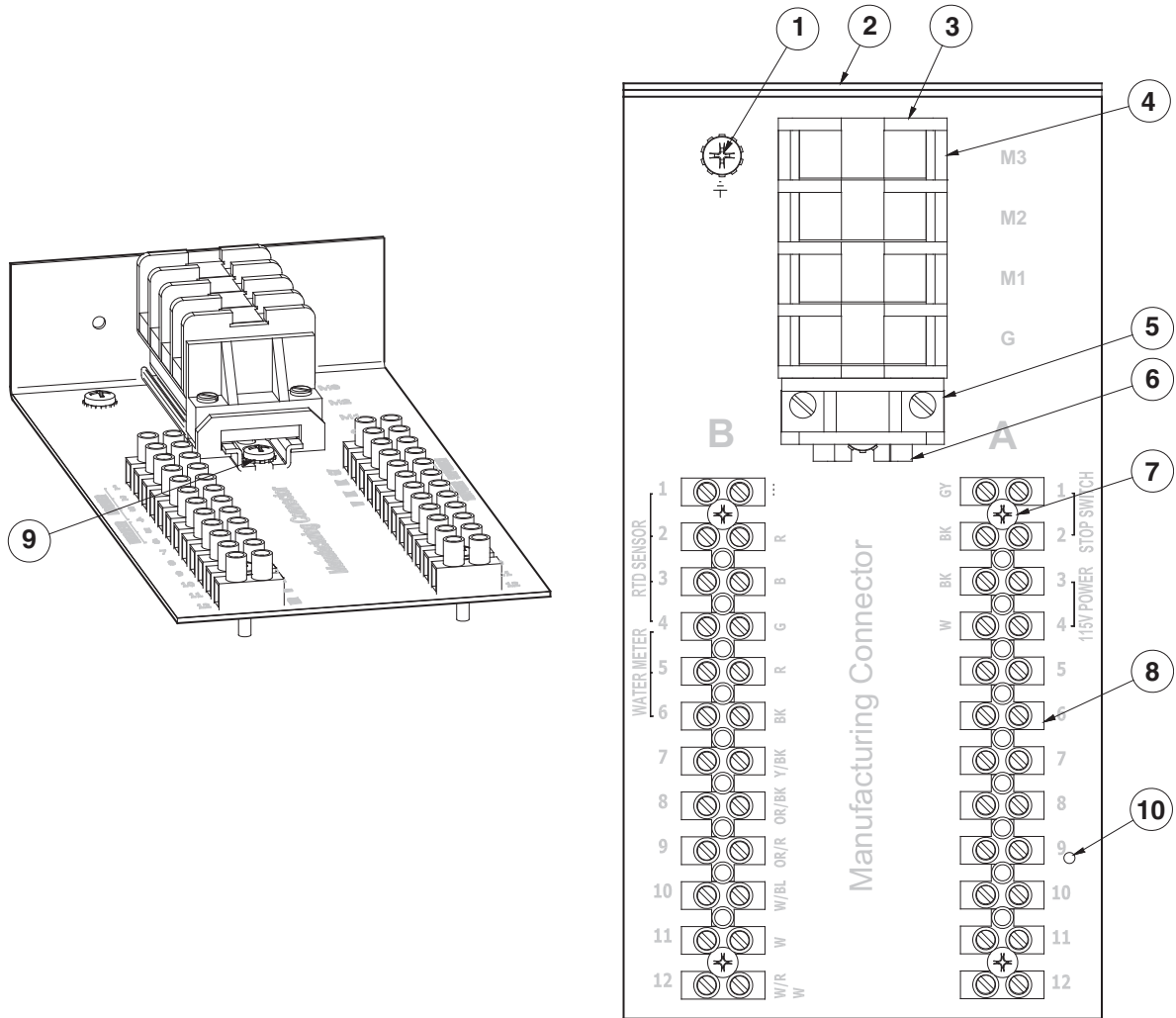

ITEM NO.	PART NO.	DESCRIPTION	QTY.
1.	FA11525-1	PHIL SCREW #10-32X3/8	1
2.	KE603401-1	COMPONANT BRACKET	1
3.	SK50054-1	TERMINAL BLOCK END BARRIER	1
4.	SK50055-1	TERMINAL BLOCK	4
5.	SK50054-2	TERMINAL BLOCK END BARRIER	1
6.	KE54761-2	TERMINAL BLOCK MOUNTING RAIL X 3 1/4	1
7.	FA15018-6	PHIL SCREW #6-32X3/4	4
8.	KE603615	TERMINAL BLOCK	2
9.	FA15018-3	PHIL SCREW #8-32X1/4	2
10.	KE603616-1	LABEL	1

PRESSURE RELIEF ASSEMBLY

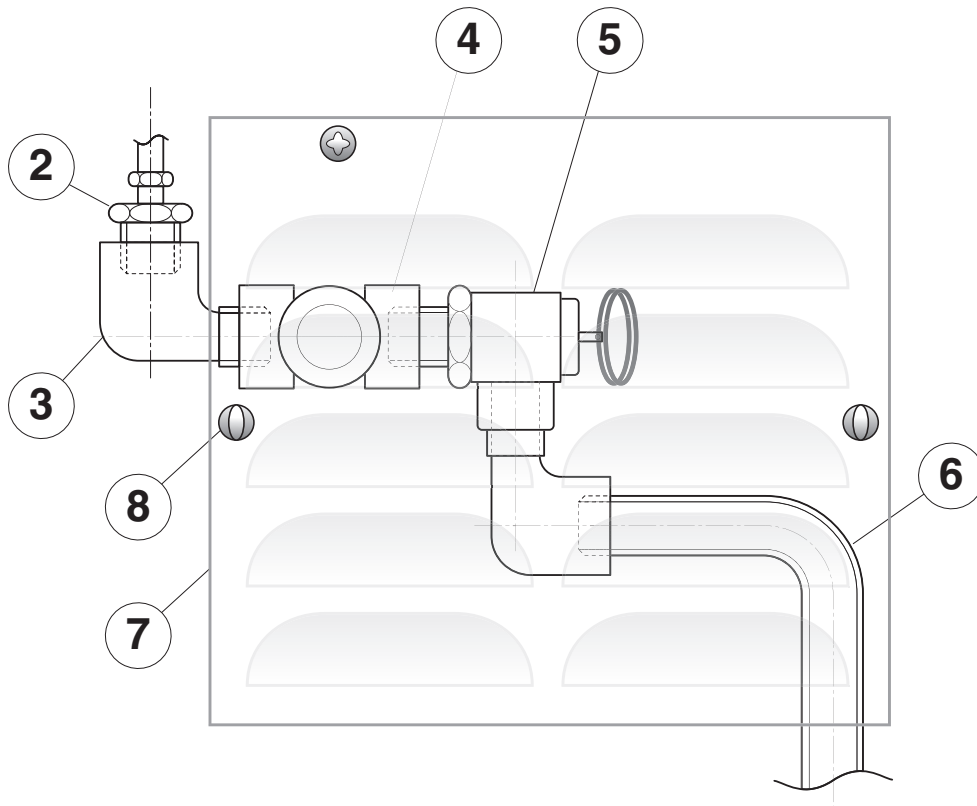
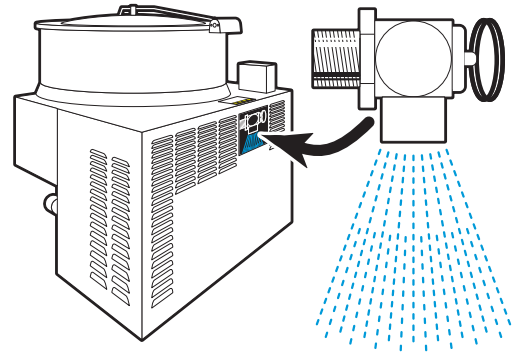

ITEM NO.	PART NO.	DESCRIPTION	QTY.
		<i>PRESSURE RELIEF VALVE ASSEMBLIES</i>	
1.	KE01450	FOR ASME KETTLES (INCLUDES #2-6)	1
	KE01450-1	FOR CE KETTLES (INCLUDES #2-6)	1
2.	FI05049	MALE CONNECTOR, 1/2" PIPE - 1/4" TUBE	1
3.	KE600812-1	STREET ELBOW, 90°, 1/2", BRASS	2
4.	KE600814-1	TEE, 1/2" FPT, BRASS	1
		<i>SAFETY VALVES</i>	
5.	KE54941-5	SAFETY VALVE, 50 PSI, 1/2" (NORTH AMERICA)	1
	KE54941-31	SAFETY VALVE, 50 PSI, 1/2", (EUROPE)	1
6.	KE54223	BLOW DOWN TUBE	1
7.	KE54864	ACCESS PANEL	1
8.	FA11518-4	THUMB SCREW, 10-32 X 1/2" L	2

PLUMBING ASSEMBLY, WATER METER

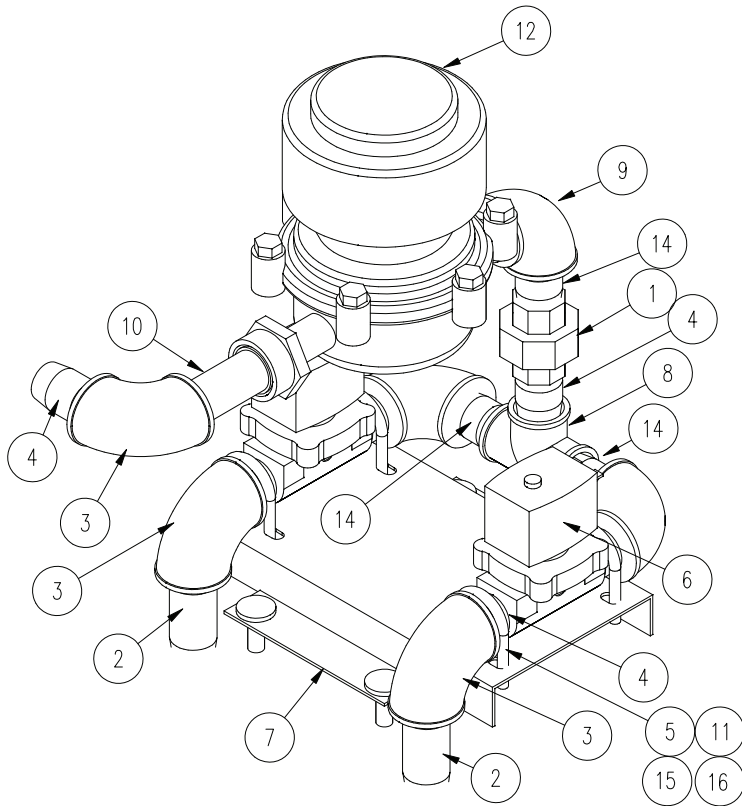

TILTING MODELS

ITEM	PART_#	DESCRIPTION	QTY	QTY
-	KE02289-2	PLUMBING; LITRE METER (HAMKGL-T)		▼
-	KE02289-1	PLUMBING; GALLON METER (HAMKGL-T)	▼	
1	FI00096	3/4 BRASS UNION	1	1
2	N0640B2-5	3/4 NPT X 2 1/2 BRASS NIPPLE	2	2
3	FI00063	3/4 NPT BRASS ELBOW	5	5
4	N0640B1-5	3/4 NPT CLOSE BRASS NIPPLE	6	6
5	FA95092-2	U-BOLT, 1/4-20	4	4
6	KE54 34-4	SOLENOID VALVE	2	2
7	KE02290	MOUNTING PLATE ASSY, HOT/COLD WM	1	1
8	FI00179	3/4 NPT BRASS FEMALE TEE	1	1
9	FI00365	3/4 X 1 REDUCING BRASS ELBOW	1	1
10	FI05153	ADAPTOR NIPPLE & GASKET	1	1
11	FA21008	S.S. NUT 1/4-20	8	8
12	KE54336	GALLON METER, HOT WATER	1	-
	KE52002-1	LITRE METER, HOT WATER	-	1
14	N0640B2	3/4 NPT X 2 BRASS NIPPLE	3	3
15	FA30505-9	FLAT WASHER 1/4 S.S.	8	8
16	FA31029	LOCKWASHER 1/4 S.S.	8	8

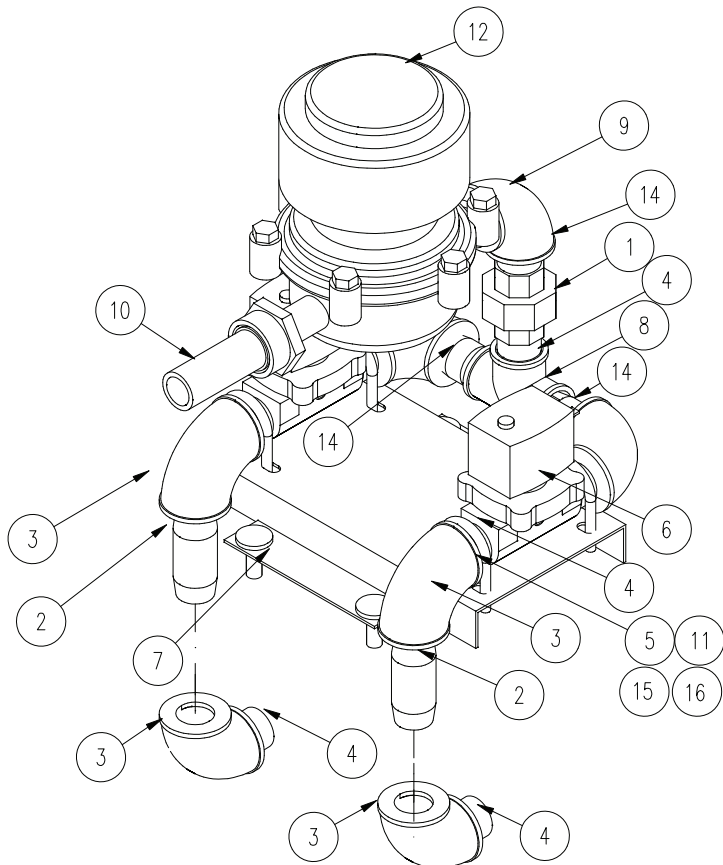

STATIONARY MODELS

ITEM	PART_#	DESCRIPTION	QTY	QTY
-	KE02289-4	PLUMBING; LITRE METER (HA-MKGL)		▼
-	KE02289-3	PLUMBING; GALLON METER (HA-MKGL)	▼	
1	FI00096	3/4 BRASS UNION	1	1
2	N0640B2-5	3/4 NPT X 2 1/2 BRASS NIPPLE	2	2
3	FI00063	3/4 NPT BRASS ELBOW	7	7
4	N0640B1-5	3/4 NPT CLOSE BRASS NIPPLE	10	10
5	FA95092-2	U-BOLT, 1/4-20	4	4
6	KE54834-4	SOLENOID VALVE	2	2
7	KE02290	MOUNTING PLATE ASSY, HOT/COLD WM	1	1
8	FI00179	3/4 NPT BRASS FEMALE TEE	1	1
9	FI00365	3/4 X 1 REDUCING BRASS ELBOW	1	1
10	FI05153	ADAPTER NIPPLE & GASKET	1	1
11	FA21008	S.S. NUT 1/4-20	8	8
12	KE54336	GALLON METER, HOT WATER	1	-
	KE52002-1	LITRE METER, HOT WATER	-	1
14	N0640B2	3/4 NPT X 2 BRASS NIPPLE	3	3
15	FA30505-9	FLAT WASHER 1/4 S.S.	8	8
16	FA31029	LOCKWASHER 1/4 S.S.	8	8

SPRING ASSISTED, 2 PIECE COVER WITH SCREEN

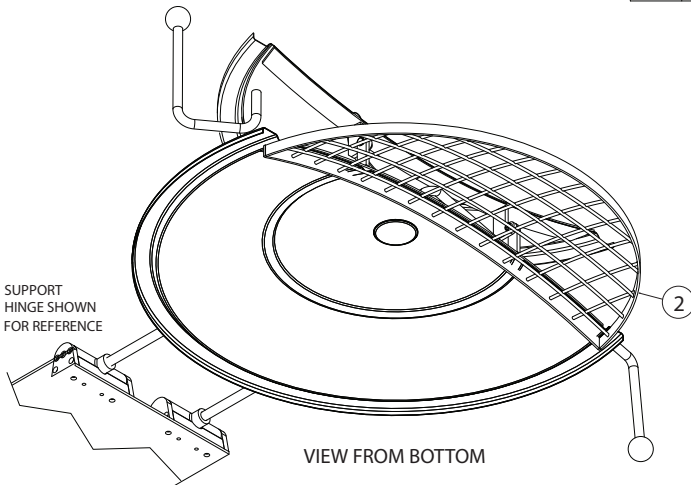
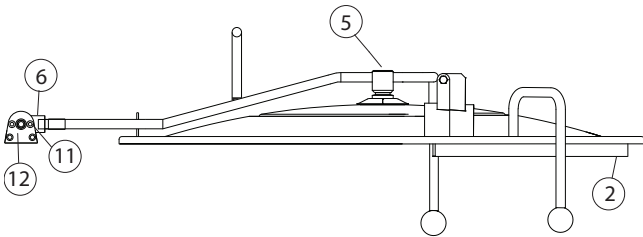
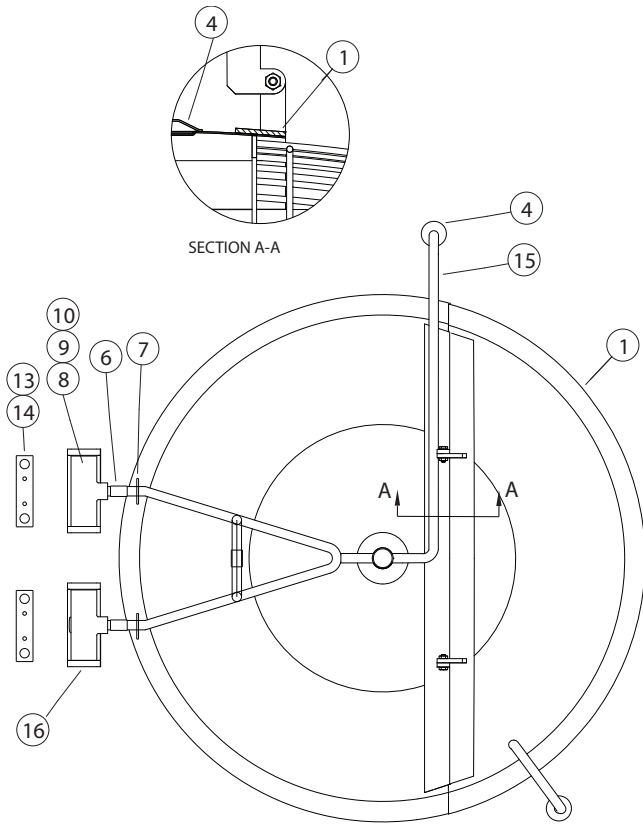

	KE003831-1	SPRING ASSISTED 2-PIECE COVER WITH SCREEN: MTPS-60 HA, NO CP OPTION	▼					
	KE003831-2	SPRING ASSISTED 2-PIECE COVER WITH SCREEN: MTPS-80 HA, NO CP OPTION		▼				
	KE003831-3	SPRING ASSISTED 2-PIECE COVER WITH SCREEN: MTPS-100 HA, NO CP OPTION			▼			
	KE003831-4	SPRING ASSISTED 2-PIECE COVER WITH SCREEN: MTPS-60 HA, CP OPTION				▼		
	KE003831-5	SPRING ASSISTED 2-PIECE COVER WITH SCREEN: MTPS-80 HA, CP OPTION					▼	
	KE003831-6	SPRING ASSISTED 2-PIECE COVER WITH SCREEN: MTPS-100 HA, CP OPTION						▼
ITEM	PART NUMBER	DESCRIPTION	QTY.	QTY.	QTY.	QTY.	QTY.	QTY.
1	KE02320-1	2-PIECE COVER ASSEMBLY	1			1		
	KE02320-2	2-PIECE COVER ASSEMBLY		1			1	
	KE02320-3	2-PIECE COVER ASSEMBLY			1			1
2	KE003832-1	SCREEN WELDMENT	1			1		
	KE003832-2	SCREEN WELDMENT		1			1	
	KE003832-3	SCREEN WELDMENT			1			1
4	KE50151-2	KNOB HANDLE	1	1	1	1	1	1
5	KE00095	HANDLE HOLDER ASS'Y	1	1	1	1	1	1
6	KE51495	COVER HANDLE TUBING	2	2	2	2	2	2
7	KE53918	ANTI-ROTATION BRACKET	3	3	3	3	3	3
8	KE00597-4	HINGE ASSEMBLY	1	1	1	1	1	1
9	FA11322	HEX BOLT 5/16-18 X 1/2 LG, SS	4	4	4	4	4	4
10	FA31030	SPLIT LOCKWASHER 5/16	4	4	4	4	4	4
11	FA11507	SCREW, 10-24 THR'D CUT SS PAN	4	4	4	-	-	-
12	KE54907-10	PLUG BUTTON	2	2	2	2	2	2
13	FA11511-17	SCREW, TORX 10-24X 3/4	-	-	-	4	4	4
14	KE53398	LOCKPLATE	-	-	-	2	2	2
15	KE02130-13	COVER HANDLE WLDT	1	-	-	1	-	-
	KE02130-14	COVER HANDLE WLDT	-	1	-	-	1	-
	KE02130-15	COVER HANDLE WLDT	-	-	1	-	-	1
16	KE00597-7	HINGE ASSEMBLY	1	1	1	1	1	1

POWER CUT-OFF SWITCH

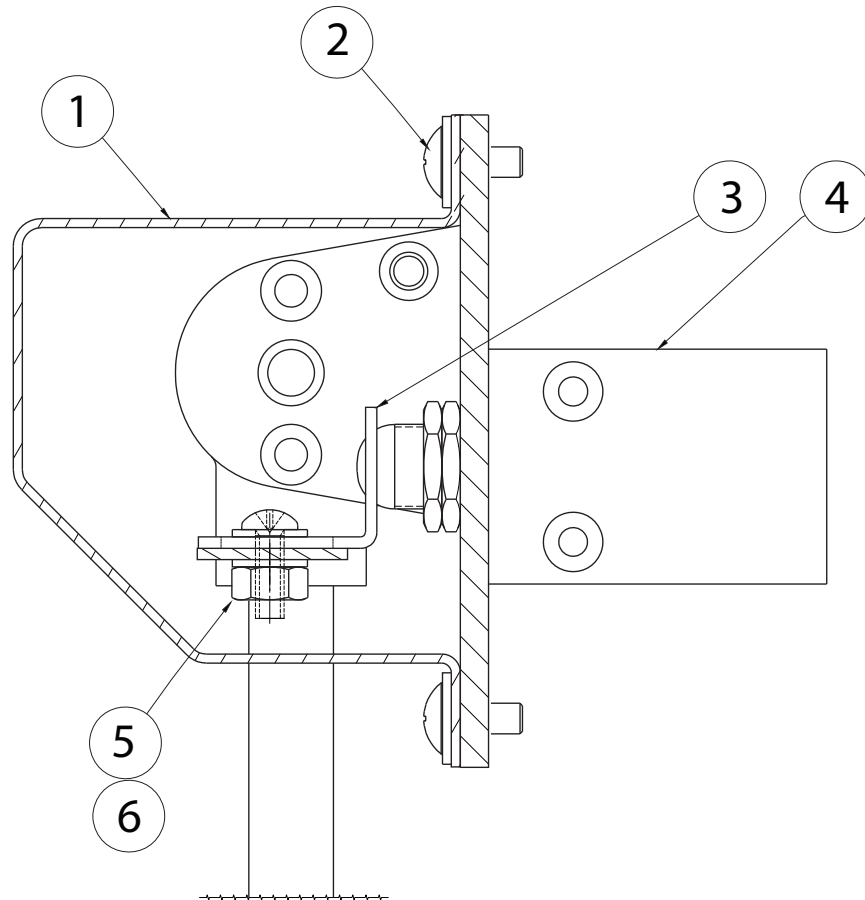

ITEM NO.	PART NO.	DESCRIPTION	QTY.
1.	KE604000	COVER	1
2.	FA11146	SCREW, #10-32X1/2	1
3.	KE604002	ACTUATOR BRACKET	1
4.	KE603998	LIMIT SWITCH	2
5.	FA21007	HEX NUT #10X32	1
6.	FA30076	#10 FLAT WASHER	1

SPARE PARTS LIST

The following is a spare parts listing of parts that wear during normal use or are apt to be misplaced during normal operation. These parts should be kept on hand to prevent loss time due to a minor problem.

PART NUMBER	DESCRIPTION	QUANTITY
KE54602-1	SCRAPER BLADE	1
KE54608	SPRING	3
FA05002-8	"O" RING	3
KE54594	PIN	1
KE54834-4	SOLENOID VALVE	1
FA05002-51	BUNA-N O-RING	5
FA05002-53	BUNA-N O-RING	5
FA05002-46	O-RING, FOOD GRADE, SIZE A0123, EPDM E 692-75	5
KE55297-3	GD2 STANDARD ACTUATOR	1
KE52936-18	FUSE, 15 AMP/600	6

The following is a recommended list of spare parts that may be required if the service agency is of some distance away or if down time must be kept to a minimum and spare parts are required for the service agent on site.

PART NUMBER	DESCRIPTION	QUANTITY
KE54834-4	SOLENOID VALVE	1
KE02291-2	AIR OPERATED CYLINDER	1
KE53469-5	IGNITION MODULE	1
KE00458-1	SOLID STATE CONTROL	1
KE50753-7	RELAY.12VDC	1
KE00515	THERMISTOR	1
KE50753-10	RELAY, 120 V HOT COLD WATER BYPASS	1
KE603208-9	CONTACTOR CARTRIDGE, NORMALLY OPEN	2
KE603208-8	CONTACTOR CARTRIDGE, NORMALLY CLOSED	2
KE50753-10	RELAY, 120V	1

Every new piece of Welbilt Foodservice equipment comes with KitchenCare® and you choose the level of service that meets your operational needs from one restaurant to multiple locations

StarCare – Warranty & lifetime service, certified OEM parts, global parts inventory, performance audited

ExtraCare — CareCode, 24/7 Support, online/mobile product information

LifeCare – Install & equipment orientation, planned maintenance, KitchenConnect™, MenuConnect®

Talk with KitchenCare® • 1-844-724-CARE • www.mtwkitchencare.com



To learn how Welbilt Foodservice and its leading brands can equip you, visit our global web site at www.welbilt.com, then discover the regional or local resources available to you.