

COOK CHILL GAS HORIZONTAL AGITATOR TILTING MIXER KETTLES

Project _____
 Item _____
 Quantity _____
 FCSI Section 11400 _____
 Approved _____
 Date _____

Models

- HAMKGL60TCC
- HAMKGL80TCC
- HAMKGL100TCC



- Variable mixer speed control from 5 to 20 r.p.m. with agitator start/stop controls
- Spring loaded teflon blades scrape the entire heated surface area
- Internal mixing fins for most efficient, uniform mixing of products
- Easily removable agitator without the use of tools
- 190 M-BTU high efficiency power burner heating system for fast heat-up and recovery times
- "Glow type" automatic safety ignition system
- Power tilt mechanism with case hardened self-locking worm and segment gear
- Kettle steam jacket permanently filled with treated distilled water
- 50 PSI steam jacket rating and safety valve
- Front mounted combination pressure-vacuum gauge
- Hot and cold water kettle filler with 60" hose
- Standard for Natural Gas operation
- Standard Electrical for agitator drive is 208V/3Ph/60Hz
- Accepted for use in USDA inspected facilities
- Gallon Markings - 10 gallon increments
- Built to CSA/NSF specifications

Short Form Specifications

Shall be Cleveland Model HA-MKGL ____ TCC, gas fired, ____ gallon operating capacity, Cook Chill, tilting horizontal agitator mixer kettle, 190M BTU High Efficiency Power Burner heating system, type 316 Stainless Steel for all food contact surfaces, 50 PSI jacket rating, Spring Assist Cover with Stainless Steel Safety Screen Guard, 3HP Motor Drive for mixer arm with variable speed control, 3" Air Operated Piston Draw-off Valve, Flush Mounted Temperature Probe, Automatic Water Meter for cold water.

Standard Features

- Full 60, 80 or 100 gallon working capacity
- Type 316 stainless steel for all food contact surfaces
- Precise solid state temperature control
- Solid state low water safety controls in a plug-in module
- L.E.D. indicators for heat cycle and low water warning
- 3" diameter air operated flush mounted piston draw-off valve with variable control (requires air compressor)
- Flush mounted, easily removable temperature probe
- Spring assisted two piece stainless steel cover equipped with stainless steel screen guard with interlocking safety system
- Three (3) horse power horizontal agitator drive

Options & Accessories

- **Kettle Mounted Control Option**
 - GMC1/LMC1: Automatic Water Meter (Gallons or Liters – specify)
 - DTCl: Digital Temperature Control and Indicator with automatic steam control
 - TCR-DTCl: Temperature Chart Recorder with Digital Temperature Control and Indicator
 - AWC1: Automatic Water Cooling
- **Remote Floor Mounted Controls Option**
 - HASGCH: Single Floor Mount remote control center, includes DTCl Temperature control & indicator, TCR temperature chart recorder, GMC1 automatic water meter
 - HADGCH: Dual twin Floor Mount remote control center, includes DTCl Temperature control & indicator, TCR temperature chart recorder, GMC1 automatic water meter
 - HASGLC: Lockable Control Center for Prisons
- Food Strainer (FS)
- Kettle Accessory Kit (KAK) includes:
 - Clean-up Brush (CB)
 - 36" Kettle Paddle (KP)
 - 36" Kettle Whip (KW)
 - 36" Kettle Brush (KB)
 - Draw-off Brush (DB)
 - 24 oz. Ladle (KL)
- Option for propane gas operation (PG)
- Voltage option for agitator drive other than standard 208V/3Ph/60Hz
- 3" diameter, 90° Elbow
- Flow Diverter
- 3" Butterfly Valve

MODEL NO.	A	B	C	D	E	G	J	K	L	M	N	P	S	U
HAMKGL60TCC	29.50"	50.25"	62.63"	52.25"	93.50"	42.00"	78.63"	28.00"	10.38"	53.00"	65.38"	69.50"	21.25"	8.00"
HAMKGL80TCC	33.00"	51.75"	66.13"	53.75"	98.00"	45.69"	84.63"	30.00"	11.44"	57.00"	68.88"	69.00"	20.50"	9.00"
HAMKGL100TCC	35.50"	54.25"	68.63"	55.25"	104.00"	48.19"	96.25"	32.00"	11.63"	66.00"	71.38"	71.50"	22.00"	10.00"

- NOTES:
1. Manufacturer must be notified if unit will be operating above 2,000 foot altitude.
 2. Consult factory for manufactured gas.
 3. All vertical dimensions shown are minimum. Feet are adjustable to 1" maximum.
 4. Refer to document KE95504-11 for specific voltage, phase, wattage & other related electrical information.

MODEL	ELECTRICAL SUPPLY:	GAS SUPPLY: (PIPING 3/4 NPT)
HAMKGL60TCC	VOLTS: 208/240	TYPE: NAT or LP
HAMKGL80TCC	PHASE: 3	BTU RATING: 190,000 per HR
HAMKGL100TCC	AMPS: 15	WATER COLUMN: 3.5
	FREQ: 60 HZ	BTU PER CU. FT.: 1000 (NAT) 2500 (LP)
		SUPPLY PRESSURE: 4" TO 14" W.C.

AIR SUPPLY: (PIPING 1/2 NPT)	APPROVALS				CLEARANCE:	SHIPPING WEIGHT
	AGA	CGA	CE MARK	NSF		
PRESSURE: 90-100 PSI	✓	✓		✓	RIGHT: 3 inches LEFT: 3 inches REAR: 3 inches ALLOW 12" SPACE MINIMUM ON LEFT SIDE FOR SERVICE	60 GAL 1,010 LBS
FLOW RATE: 5 CU. FT PER MIN.						80 GAL 1,120 LBS 100 GAL 1,325 LBS

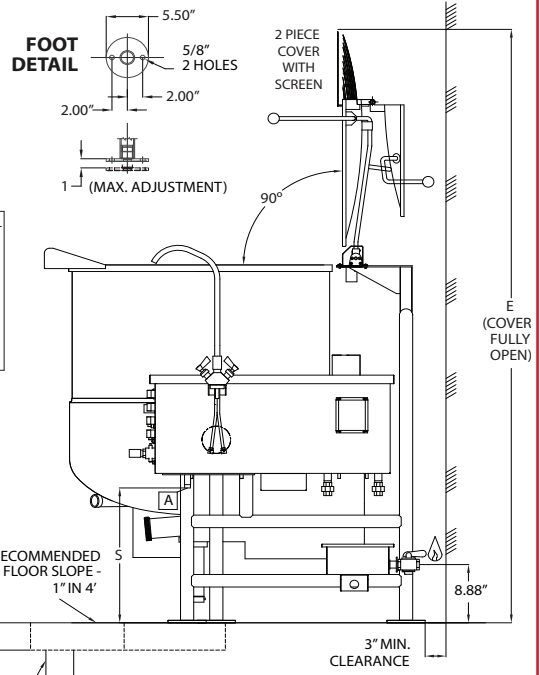
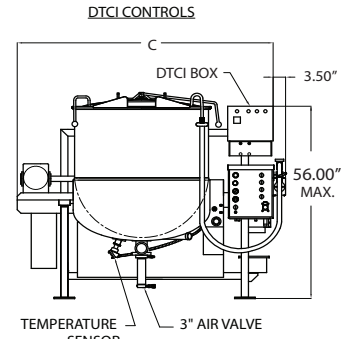
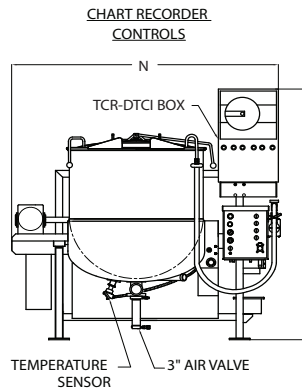
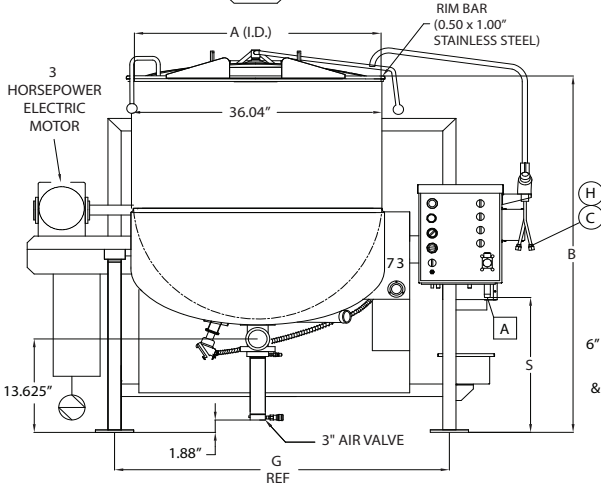
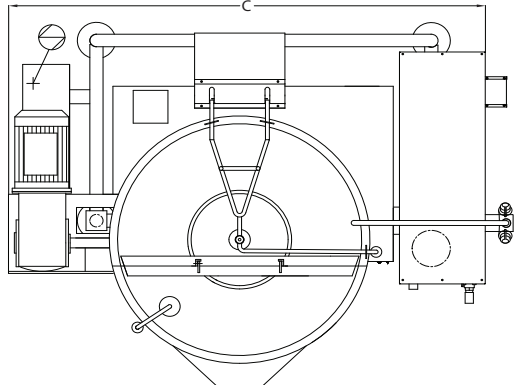
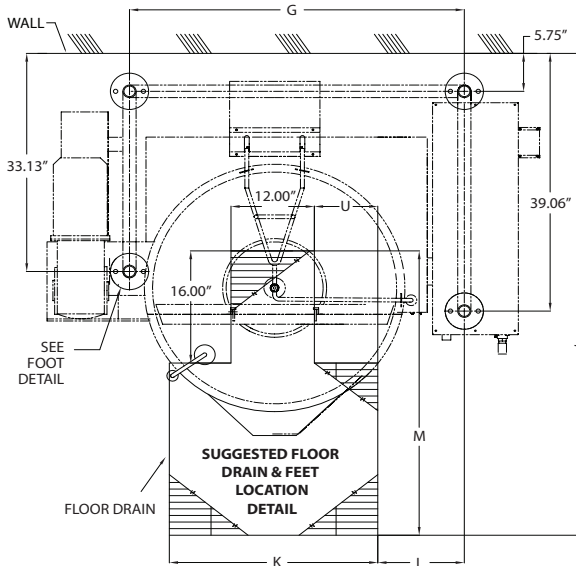

- LEGEND:
- ELECTRICAL SUPPLY
 - GAS
 - AIR
 - COLD WATER
 - HOT WATER

PIPE DRAIN RECOMMENDED MINIMUM VALVE SIZE PLUS 1"

Cleveland Range reserves right of design improvement or modification, as warranted.

(NOT TO SCALE)

Cook Chill Systems