

Claris Flow Sensor

Installation and Operation Guide..... **US**



Index

1. General Information	4
2. Technical Data	4
3. Instructions.....	4
3.1 General	4
3.2 Measurement tips	4
3.3 Staff.....	4
3.4 Safety Information.....	5
3.5 Disclaimer	5
3.6 Declaration of Conformity	5
4. Installation.....	5
4.1 First time installation of the CLARIS filter system with the sensor unit.....	5
4.2 Installation of the sensor unit to an existing CLARIS filter system.....	5
4.3 Programming and Display Unit	5
4.3.1 Mounting with double-sided adhesive tape	5
4.3.2 Mounting using a screw.....	5
5. Programming	6
5.1 Setting the filter capacity in gallon	6
5.2 Resetting the filter capacity (after replacement of filter cartridge).....	6
5.3 Memory Access.....	6
5.4 Total filtrate volume	7
6. Battery Replacement	7
7. Service / Maintenance	7

Overview of components

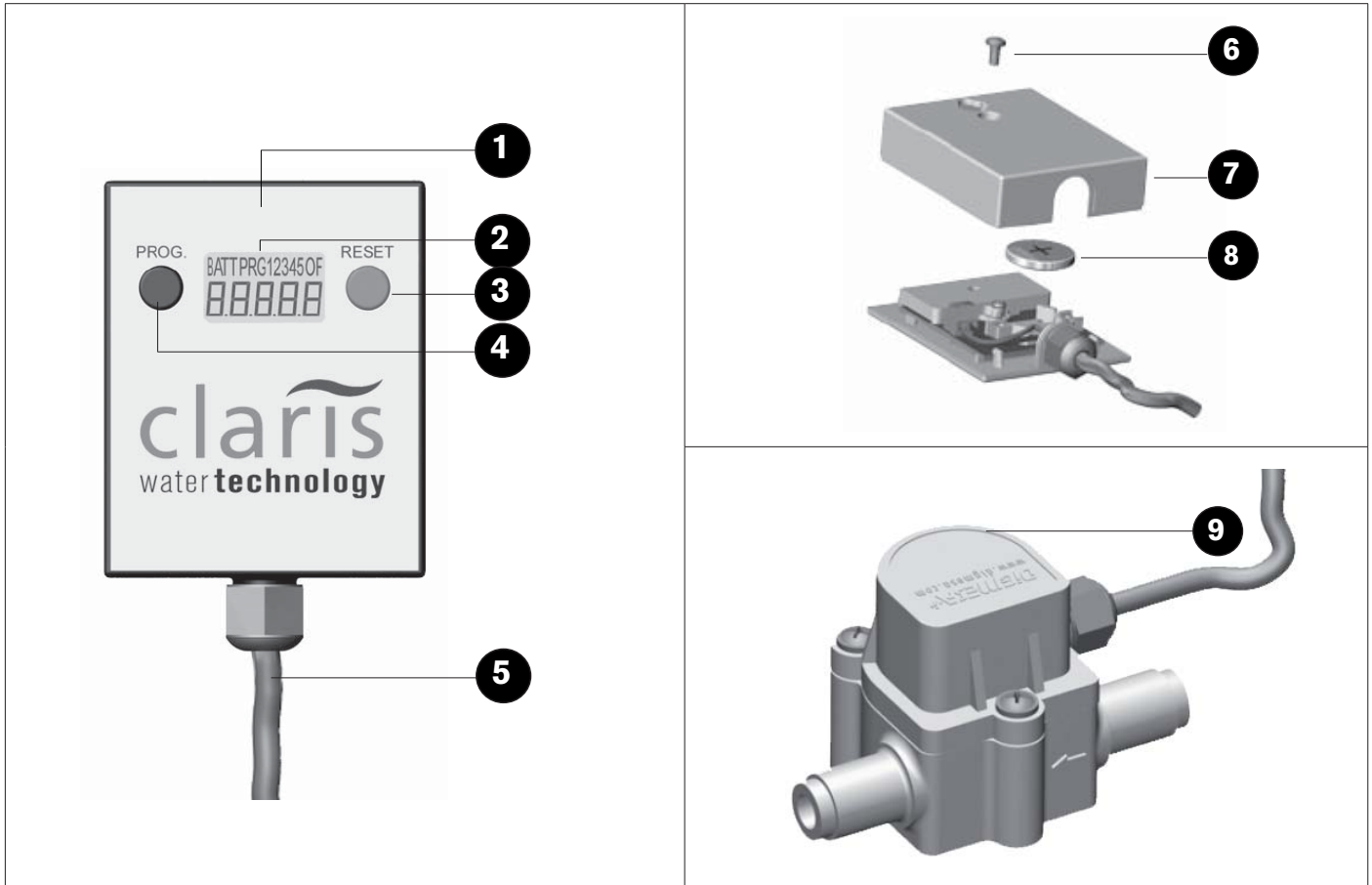

Definitions of terms:

- 1 programming and display unit
- 2 display
- 3 "RESET" button
- 4 "PROG" button
- 5 cable 1.5 m
- 6 screw
- 7 housing
- 8 coin cell 3VDC, type CR2032
- 9 sensor unit with G 3/8" F nut and G 3/8" M thread

1. General Information

The CLARIS Flow Sensor has been developed to monitor the usage rate of the CLARIS water filter system and to determine the optimum cartridge replacement interval. After setting the sensor to monitor the specific filter size, the CLARIS Flow Sensor continually measures the filtrate volume to calculate and display the remaining filtration capacity in US gallons. Once the available filtration capacity is exhausted ("zero") or after 12 month operation, the filter cartridge has to be replaced.

The programming and display unit provides the following information:

- residual filtration capacity of the cartridge
- total filtrate volume since CLARIS Flow Sensor installation
- filtrate volume and operation time of the last five installed filter cartridges

2. Technical Data

Sensor Unit	Standard Version	High Flow Version
Connection	In 3/8" F nut / out 3/8" M	In 3/8" F nut / out 3/8" M
Operating Pressure (min/max)	29 – 116 psi (2-8 bar)	29 - 116 psi (2-8 bar)
Flow rate	3 - 26 GPH (10 - 100 LPH)	26 - 185 GPH (100 - 700 LPH)
Pressure loss	3 psi at 26 GPH	3 psi at 185 GPH
Precision (horizontal installation)	+/- 5 %	+/- 5 %
Water Temperature (min/max)	39 - 86 °F (4-30°C)	39 - 86 °F (4-30°C)
Ambient Temperature (min/max)	39 - 104 °F (4-40°C)	39 - 104 °F (4-40°C)
Dimensions (BxHxT)	80mm x 46mm x 43mm	80mm x 46mm x 43mm
Installation position	Horizontal recommended	Horizontal recommended

Programming and Display Unit	Standard Version	High Flow Version
Splash proof	IP X4	IP X4
Display	5 digits	5 digits
Counter	Downwards 99999 to -9999	Downwards 99999 to -9999
Dimensions (BxHxT)	50mm x 17mm x 73mm	50mm x 17mm x 73mm
Cable	1.5 meter, 2 x 0.25 mm ²	1.5 meter, 2 x 0.25 mm ²

Order Number	Standard Version	High Flow Version
Flow Sensor with programming and display unit (3/8" thread)	4339-31	4339-32

3. Instructions

3.1 General

- Read the Installation and Operation Guide carefully before each installation and start of operation. Follow all steps exactly as indicated in the instructions.
- Ensure that the flow direction corresponds to the arrows on the sensor unit.
- It is recommended to mount the sensor horizontally for greatest accuracy.
- Don't expose the Flow Sensor to any mechanical stress.
- Ensure that all seals and connections are made using suitable components.
- Check that all air is vented from the system before the start of operation.

3.2 Measurement tips

- Avoid rapidly pulsating water flow
- Minimise water-air mixture
- Ensure the unit is sited away from strong magnetic fields
- Be aware that the unit is calibrated to measure water flow and hence measurements may vary with other fluids

3.3 Staff

The installation and maintenance of the CLARIS Flow Sensor may only be carried out by trained and authorised personnel.

3.4 Safety Information

1. Follow all instructions and guidelines.
2. Use only standard battery cells of the type CR2032.
3. Ensure that the battery cover is properly sealed to avoid debris and moisture penetration.
4. The battery should be removed in the following cases:
 - Water or other liquids ingress into the appliance.
 - If the Display does not function.
 - If the housing of the Programming and Display Unit is damaged.
 - If the PROG or RESET buttons do not function.

All repairs should only be carried out by an Authorised Service Agent.

3.5 Disclaimer

Information contained in this document is believed to be accurate at the time of publication, but does not constitute a contractual offer. The right is reserved to alter specifications without prior notice. Illustrations and tabulated data are for guidance only. Aquis does not assume liability for any damages, including subsequent damages, that may result from incorrect installation or usage of the products. Aquis does not assume liability for damage caused by using parts from other manufacturers.

3.6 Declaration of Conformity

Available on request.

4. Installation

4.1 First time installation of the CLARIS filter system with the sensor unit

For initial installation of CLARIS filter system with CLARIS Flow Sensor, first install the CLARIS filter head (see Operation Guide "Clariss filter systems" chapter 6).

4.2 Installation of the sensor unit to an existing CLARIS filter system

If a CLARIS filter system is already in place, follow the following steps:

1. Remove connection hose from the filter head liquid outlet using an appropriate tool.
2. Connect the sensor unit with the nut directly to the filter head (use the provided flat gasket).
3. Connect the hose to the outlet of the sensor unit (use the flat gasket).



NOTE

Disconnect the CLARIS filter head from the water supply before start of installation.

Ensure correct alignment of sensor unit with direction of flow (arrow on the housing).

Use only appropriate tools for the installation (spanner 19 mm).

The sensor unit should be mounted horizontally.

Don't expose the Flow Sensor to any mechanical strain; particularly take care of any leverage effect from kinked or bent hoses. If necessary brace the connections.

Use only suitable gaskets and connecting materials.

Before start of operation vent all air from the system.

4.3 Programming and Display Unit

4.3.1 Mounting with double-sided adhesive tape

1. Fasten an approx. 40 x 40 mm piece of double-sided adhesive tape to the back wall of the programming and display unit.
2. Position the programming and display unit on the desired position.













4.3.2 Mounting using a screw

1. Flat head screw with max. 4 mm shaft diameter is recommended.

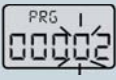

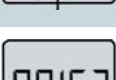

5. Programming

5.1 Setting the filter capacity in gallon

Please follow the capacity instruction for the appropriate CLARIS filter cartridge (see CLARIS filter Guide).





Step	Button		Display
1.		Press the „PROG“ button once - „PROG“ flashes	
2.		Press the „RESET“ button once – active digit flashes	
3.		By pressing the „RESET“ button, set the desired value - For the digit „2“, press „RESET“ two times	
4.		Press the „PROG“ button once to confirm the desired digit and switch to the next digit. - Active digit flashes	
5.		By pressing the „RESET“ button, set the desired value - For the digit „6“, press „RESET“ six times	
6.		Repeat Steps 4 and 5 until all digits have been set	
7.		Press the „PROG“ button once - Final filter capacity is set - the programmed value appears	

5.2 Resetting the filter capacity (after replacement of filter cartridge)



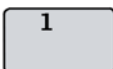

Step	Button		Display
1.		- Display flashes Programmed filter capacity exhausted or maximum operation time of 12 months exceeded	
2.		Press and hold the „RESET“ button for approx. 3 sec. - „RESET“ appears on the display	
3.		The filter capacity is reset and the last programmed value appears	

5.3 Memory Access

There is a possibility to individually retrieve the operating data (volume in gallon) and operation time in month of the last five filter cartridges installed.

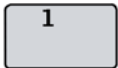
Step	Button		Display
1.		Press and hold the „PROG“ button for approx. 5 sec. - The digit „1“ appears	
2.		The display indicates the volume in gallons and the operation time in months of the last cartridge in place	
3.		Press the „RESET“ button once - The operating data of the next to last filter cartridge are displayed	
4.		Repeat Step 3 to access to the memories of the prior installed filter cartridges	
5.		Press the „PROG“ button once - The current filter capacity is displayed	

5.4 Total filtrate volume (from the start of first operation)

Step	Button		Display
1.		Press and hold the „PROG“ button for approx. 5 sec. - The digit „1“ appears	
2.		Once again press and hold the „PROG“ button for approx. 5 sec. - The complete filtrate volume from the start of first operation appears	
3.		Press the „PROG“ button once - The current filter capacity is displayed	

6. Battery Replacement

Step	Button		Display
1.		On the display appears „BATT“ - The battery is empty and must be replaced	

1. Loosen the screw (page 3, pos. 6) on the cover (page 3, pos. 7) with a Phillips head screwdriver.
2. Remove the cover and remove the old battery.
3. Insert the new battery (type CR2032) and press downwards (observe the polarity). Then place back the cover to the housing and tighten the screw.

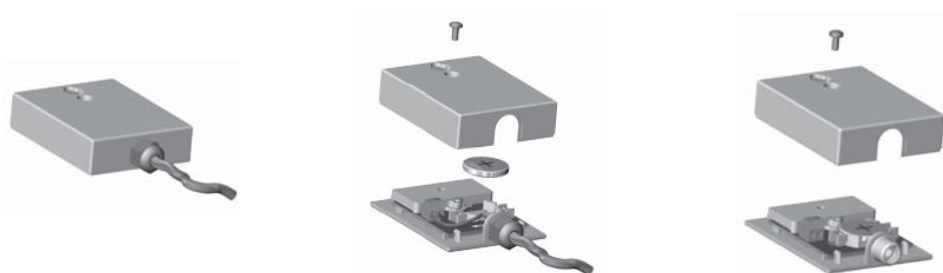

NOTE: All stored data remain after the battery replacement.

7. Service / Maintenance

Check the CLARIS Flow Sensor for leaks daily.
In the event of a fault, please contact your service contractor.

Aquis GmbH, Balgacherstrasse 17, CH-9445 Rebstein, Schwitzerland
Telefon: +41 (0)71-7759500, Telefax: +41 (0)71-7771641
E-Mail: info@aquis.ch, www.aquis.ch