

SteamCub™
 ES2469 STACKING STAND
 OPEN TYPE STAND, ALL STAINLESS STEEL

Project _____
 Item _____
 Quantity _____
 FCSI Section 11400 _____
 Approved _____
 Date _____

SteamCub™ Boilerless Connectionless Steamer

Models

- ES2469



Model ES2469 shown with optional 1SCE™ Steamers



Standard Features

- Stand designed specifically for mounting two each (2) 1SCE™ SteamCub's.
- All Stainless Steel welded construction with 1.25" square tubing.

Short Form Specifications

Cleveland, Stacking Equipment Stand, Model ES2469, designed to stack (2) 1SCE™ SteamCub Steamers. Model ES-2469, Open type stand. All stainless steel welded construction with 1.25" square tubing.

KE004046-46

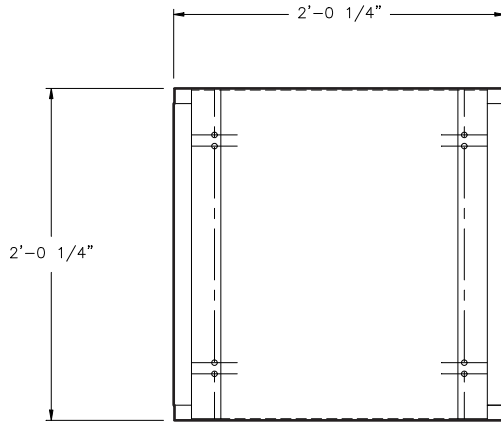

ES-2469
Installation
Requirements

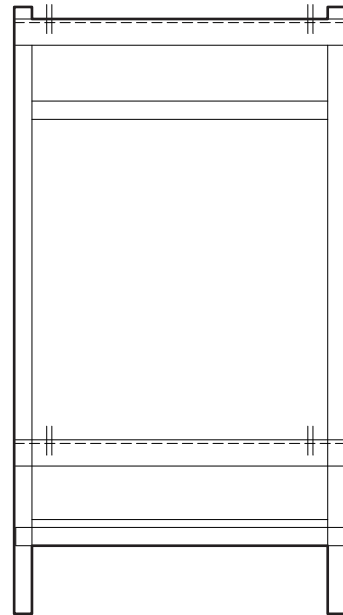
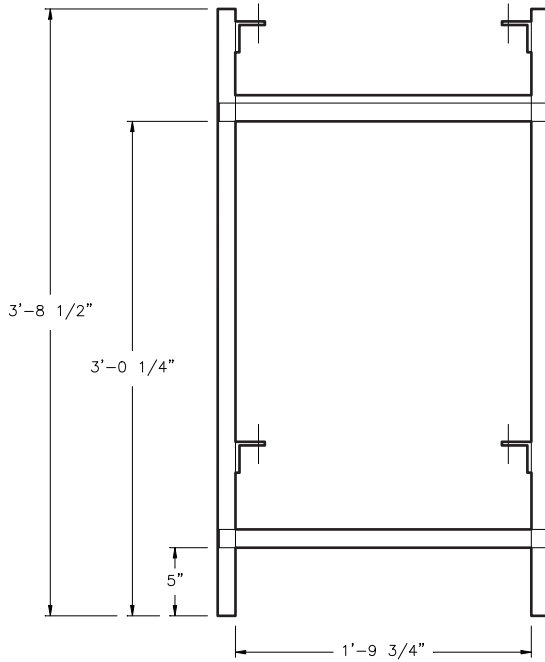

NOTES:

Cleveland Range reserves right of design improvement or modification, as warranted.
Many regional, state and local codes exist and it is the responsibility of the owner and installer to comply with the codes.
Cleveland Range equipment is built to comply with applicable standards for manufacturers. Included among those approval agencies are U.L./NSF#4 and CSA (AGA, CGA).

(NOT TO SCALE)