

Data Logger Documentation

How To Use

A microSD card must be inserted at all times for the system to run. Whenever the switch is turned on, a new file is created on the microSD card. The date, time and temperature probe reading is logged into this file every 30 seconds. The format of the log is year, month, day, hour, minute, second, temperature.

For example, the log entry “21,04,10,15,17,09,32.0” reflects 32 degrees Fahrenheit logged at 3:17:09 PM on April 10, 2021.

To transfer the data to a USB drive, plug in a USB drive, ensure the switch is turned off, and press the usb transfer button. The USB transfer button will be ignored if the switch is turned on.

When the USB button is pressed, the green USB button light will turn on and remain on until the transfer is complete. Once the transfer is complete, the green USB light will flash on and off until the USB drive is removed.

If a USB is not inserted and the USB button is pressed, the USB button light will remain on waiting for a USB to be inserted. This will eventually time out at 20 seconds and the light will turn off.

Boot Up Process

As soon as the device has been programmed, it will immediately calibrate the ADC. Please ensure that a 100 ohm (+/-0.1%) resistor is connected to the device before programming. If recalibration is required, the microcontroller may be programmed again, or a button sequence (see below) can be entered to recalibrate with a 100 ohm (+/-0.1%) resistor connected. The device will then enter the real time clock setup.

Data Logger Documentation

Real Time Clock Setup

During this setup, the user will be prompted “d1” to “d5”. When prompted “d1” on the display, press any of the up or down keys to begin incrementing or decrementing the values.

d1 = Year Range: 21 - 50
d2 = Month Range: 01 - 12
d3 = Day Range: 01 - 31
d4 = Hour Range: 00 - 23
d5 = Minute Range: 00 - 59

For example:

d1 = 21 d2 = 04 d3 = 18

d4 = 13 d5 = 48

Time Entered = April 18, 2021, 1:48 PM

Note, the setup does include a roll over effect for value selection. For example, when selecting the hour, the user may decrement at “00” to get to “23” quicker rather than incrementing 23 times. Also note, the real time clock will deal with leap year on its own, and it is the user’s responsibility to enter the correct date for proper functionality. For example, entering Feb 30, 2021 will be accepted by the real time clock, but may result in functionality errors.

BUTTON Sequences

The system comes with 2 button sequences. Please note, a microSD card has to be inserted at all times to enter these sequences.

Sequence 1 = Hold “Up” and “Enter” buttons down for 5 seconds

This will allow the user to re-enter the date and time for the real time clock. The seven segment displays will flash “c1” 3 times, then display “d1” indicating the start of the real time clock detailed above in the real time clock setup.

Sequence 2 = Hold “Down” and “Enter” buttons down for 5 seconds

This sequence is used to recalibrate the ADC. This sequence should be used once a 100 ohm (+/-0.1%) resistor is connected to the device. The seven segment displays will flash “ca” 3 times, then turn off, indicating a successful calibration.

Data Logger Documentation

Debug Messages

While the Switch is OFF

- E0 - MicroSD is mounted
- E8 - Mounting MicroSD Card (May remain on screen during boot up for up to 15 seconds to create configuration files)
- E9 - MicroSD is not mounted

When the switch is turned ON

- E1 - Creating New File and Log First Entry
- E2 - File created, Logging Periodically
- When Switch is Turned Off, E0 or E9 will be shown

If the USB Transfer button is pressed

- F0 - Button Press Detected, Opening File on MicroSD
- F1 - MicroSD Card File Opened, Read First Line
- F2 - First Line Read, Create/Open USB File
- F3 - USB File Opened, Write First Line Read Earlier from MicroSD
- F4 - First Line Written, Transfer all contents from MicroSD Card File
- F5 - File Transferred, Close Both Files and Delete MicroSD File
- F6 - File Deleted and USB File Closed, Clear All Transfer Buffers
- F7 - All Files Transferred, Wait for USB Dismount (USB LED Flashing)

During this sequence, F0 would be seen first for a few seconds, followed by F1-F6 repeated for every data file on the microSD card, and finally F7 would be seen while the USB and microSD files are being closed. Once the USB Button LED begins to flash, the USB may be ejected.

Warning, ejecting the USB or microSD card during transfer may corrupt the drives.

Data Logger Documentation

Wiring Diagrams

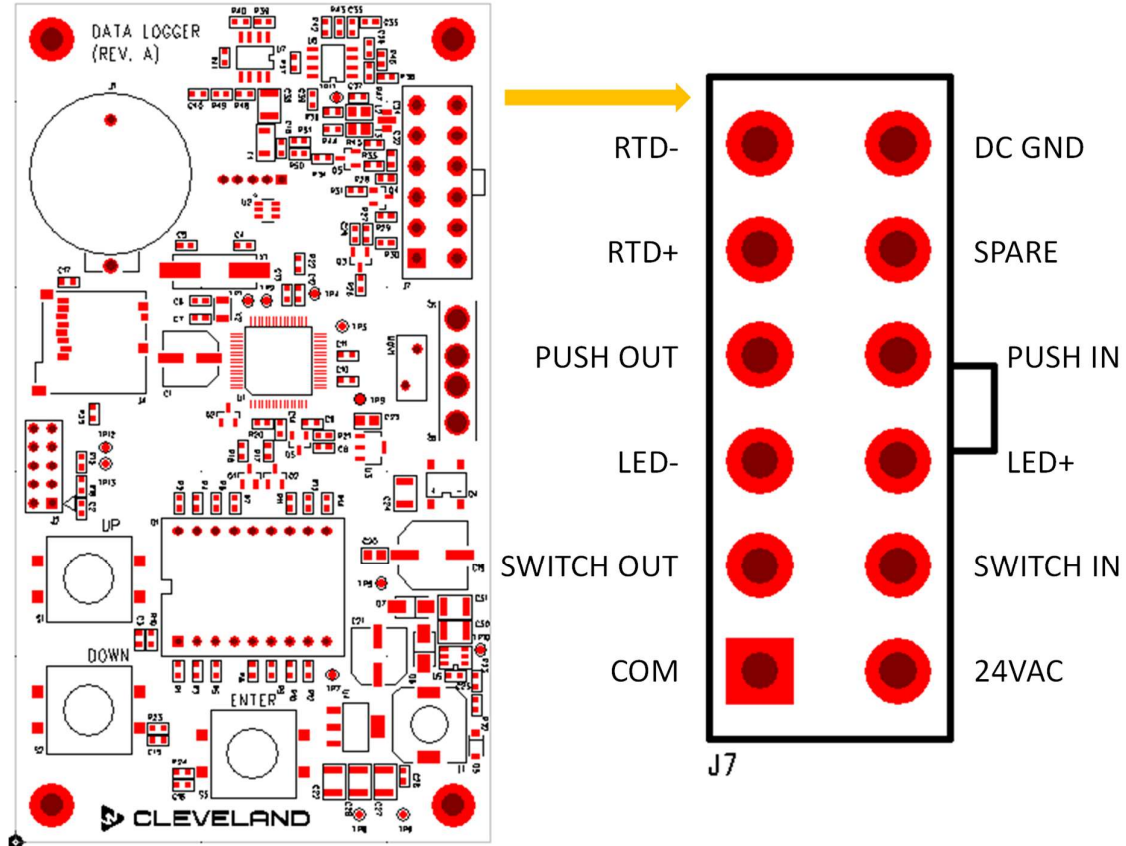

Data Logger Documentation

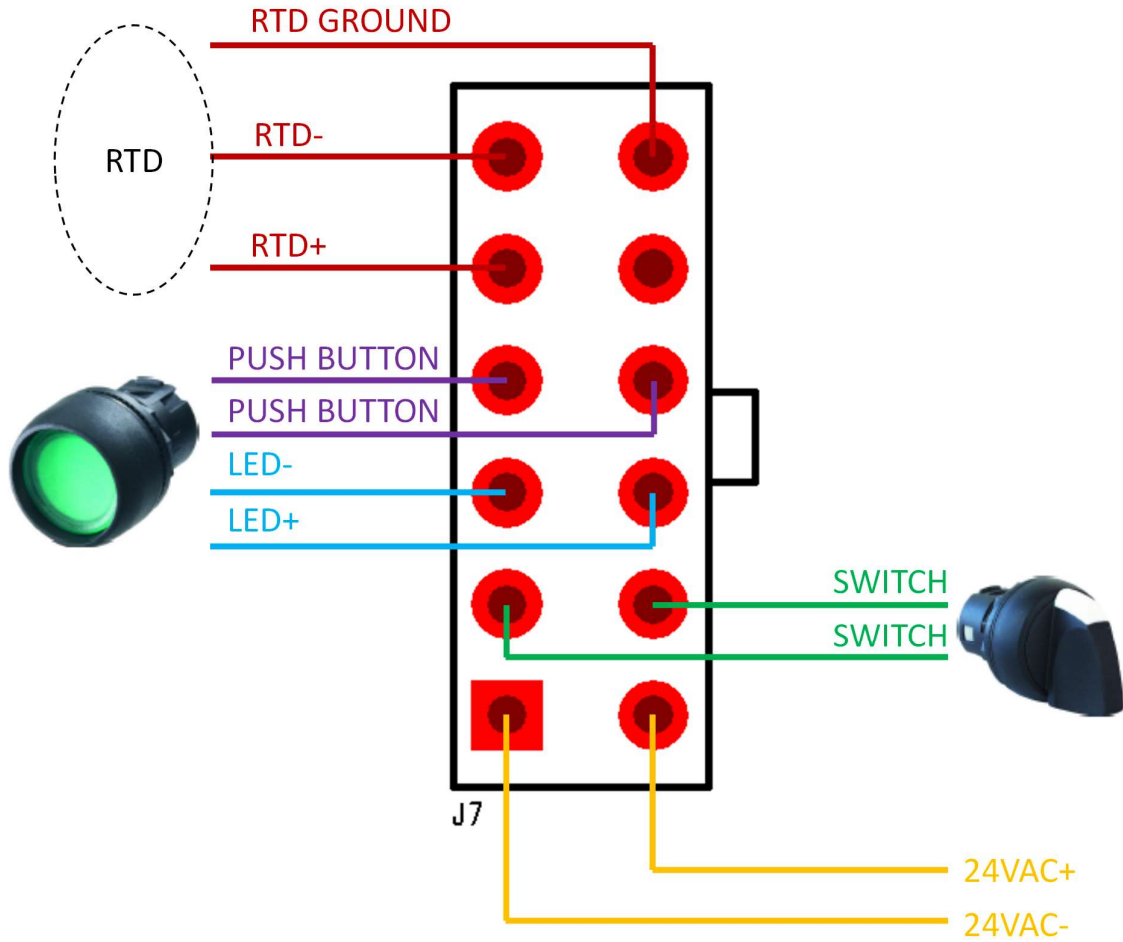

Note, for a 2-wire RTD, please tie RTD+ and RTD- together and connect to one end of the RTD, and connect RTD GROUND to the other end of the RTD.