

Project \_\_\_\_\_  
 Item \_\_\_\_\_  
 Quantity \_\_\_\_\_  
 FCSI Section 11400 \_\_\_\_\_  
 Approved \_\_\_\_\_  
 Date \_\_\_\_\_

## REMOVABLE DAIRY VALVE\*

### Models

- DVF2 • DVF3



3" Removable Dairy Valve with Acme Thread (DVF2) shown on KGL-40

### Standard Features

- 2" or 3" diameter removable sanitary stainless steel mirror finish Dairy Valve (DVF2 or DVF3)
- Acme Thread for easy removal/cleaning
- Available as substitute on any Cleveland stationary kettle with a Tangent-Draw Off Valve (not available on tilting models)

NOTE: The DVF2 and DVF3 (Dairy Valve with Acme Thread) must be configured on kettle at time of purchase. It cannot be replaced, installed, or retro-fitted in the field.

### Options & Accessories

- 2" or 3" Wrench (WR2 or WR3)
- Kettle Accessory Kit (KAK) includes:
  - Cleaning Brush (CB)
  - 36" Kettle Paddle (KP)
  - 36" Kettle Whip (KW)
  - 36" Kettle Brush
  - Draw-Off Brush (DB)
  - 24 oz. Ladle (KL)

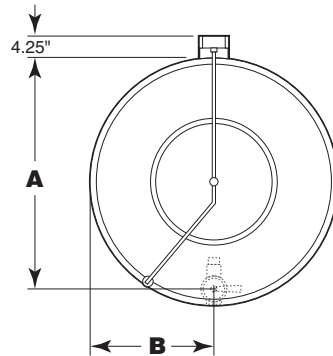
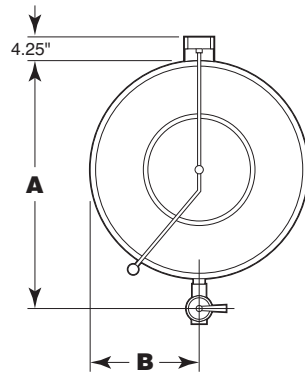
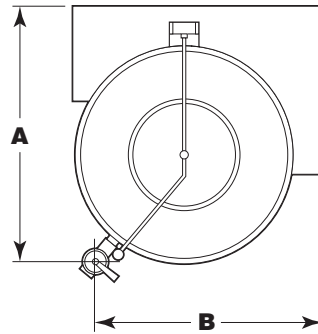
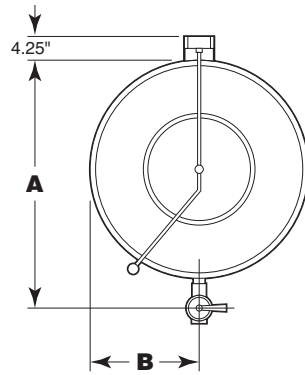
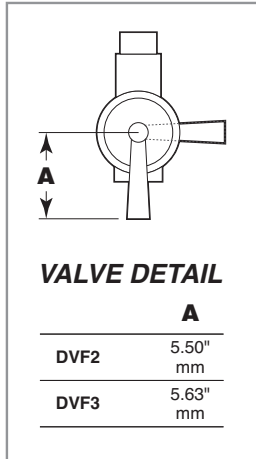

### ELECTRIC STATIONARY KETTLES

	<b>A</b> (DVF2)	<b>A</b> (DVF3)	<b>B</b> (DVF2 & DVF3)
<b>KEL-25</b>	26.75" 686mm	27.75" 705mm	11.00" 279mm
<b>KEL-30</b>	29.75" 756mm	30.75" 781mm	12.50" 318mm
<b>KEL-40</b>	31.50" 800mm	32.50" 826mm	13.50" 343mm
<b>KEL-60</b>	35.00" 889mm	36.00" 914mm	15.25" 387mm
<b>KEL-80</b>	38.50" 978mm	39.50" 1003mm	17.00" 432mm
<b>KEL-100</b>	41.00" 1041mm	42.00" 1067mm	18.25" 464mm

### GAS STATIONARY KETTLES

	<b>A</b> (DVF2)	<b>B</b> (DVF2)	<b>A</b> (DVF3)	<b>B</b> (DVF3)
<b>KGL-40</b>	35.75" 908mm	26.50" 673mm	37.50" 953mm	27.63" 702mm
<b>KGL-60</b>	37.75" 959mm	28.88" 733mm	39.75" 1010mm	30.00" 762mm
<b>KGL-80</b>	39.13" 994mm	31.00" 787mm	41.63" 1057mm	32.50" 826mm
<b>KGL-100</b>	40.25" 1022mm	32.50" 826mm	42.88" 1089mm	34.00" 864mm

### DIRECT STEAM STATIONARY KETTLES 25 - 80 GALLON MODELS

	<b>A</b> (DVF2)	<b>A</b> (DVF3)	<b>B</b> (DVF2 & DVF3)
<b>KEL-25</b>	25.88" 657mm	27.88" 708mm	11.00" 279mm
<b>KEL-30</b>	28.13" 714mm	30.50" 775mm	12.50" 318mm
<b>KEL-40</b>	29.75" 756mm	32.00" 813mm	13.50" 343mm
<b>KEL-60</b>	32.75" 832mm	35.13" 892mm	15.25" 387mm
<b>KEL-80</b>	25.13" 638mm	38.13" 968mm	17.00" 432mm
<b>KEL-100</b>	37.00" 940mm	40.25" 1022mm	18.25" 464mm

### DIRECT STEAM STATIONARY KETTLES 125 - 250 GALLON MODELS

	<b>A</b> (DVF2)	<b>A</b> (DVF3)	<b>B</b> (DVF2 & DVF3)
<b>KDL-125</b>	40.13" 1019mm	43.00" 1092mm	20.50" 521mm
<b>KDL-150</b>	40.13" 1019mm	43.00" 1092mm	20.50" 521mm
<b>KDL-200</b>	40.13" 1019mm	44.25" 1124mm	22.50" 572mm
<b>KDL-250</b>	42.38" 1076mm	46.13" 1172mm	24.00" 610mm

**NOTES:**

Cleveland Range reserves right of design improvement or modification, as warranted.  
 Many regional, state and local codes exist and it is the responsibility of the owner and installer to comply with the codes.  
 Installation of backflow preventers, vacuum breakers and other specific code requirements is the responsibility of the owner and installer.  
 Cleveland Range equipment is built to comply with applicable standards for manufacturers. Included among those approval agencies are U.L., A.G.A., NSF, ASME/N.Bd., CSA, CGA, ETL and others.

(NOT TO SCALE)