



## CONVEYORS

for Loading Products  
into the Tumble Chiller

MODELS:  CVY-220-T  CVY-220-S  
 CVY-320-T  CVY-320-S



### Cleveland Standard Features

#### Model: CVY-220-T & CVY-320-T

- Powered belt conveyor
- All stainless steel construction
- 16" wide USDA approved PVC belt with 4" high cleats
- Stainless steel ball bearings
- 3/4 Horse power TEFC motor with drive gearbox
- Variable belt speed
- Operator start/stop at loading area
- Emergency stop at tumble chiller area
- Level adjustable front roller conveyor with bag safety deflector
- Spring loaded rollers with stainless steel ball bearings
- Adjustable feet for bolting to floor

#### Model: CVY-220-S & CVY-320-S

- Powered belt conveyor
- All stainless steel construction
- 16" wide USDA approved PVC belt with 4" high cleats
- Stainless steel ball bearings
- 3/4 Horse power TEFC motor with drive gearbox
- Variable belt speed
- Operator start/stop at loading area
- Emergency stop at tumble chiller area
- Adjustable feet for bolting to floor

ITEM NUMBER \_\_\_\_\_

JOB NAME / NUMBER \_\_\_\_\_

MODEL:  CVY-320-S



### Short Form Specifications

Shall be CLEVELAND Model CVY-\_\_\_\_- \_\_, powered Belt Conveyor with 16" wide Belt with 4" high Cleats; all Stainless Steel construction; 3/4 HP TEFC motor with drive gearbox; Variable speed Belt; Start/Stop and Emergency Stop Switch.

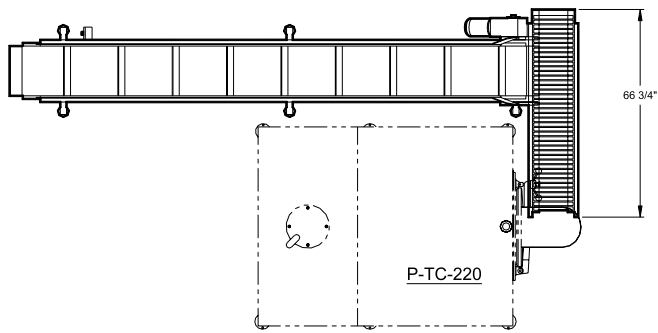

PLAN VIEW

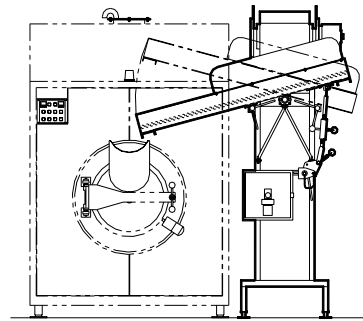

FRONT VIEW

CVY-220-T

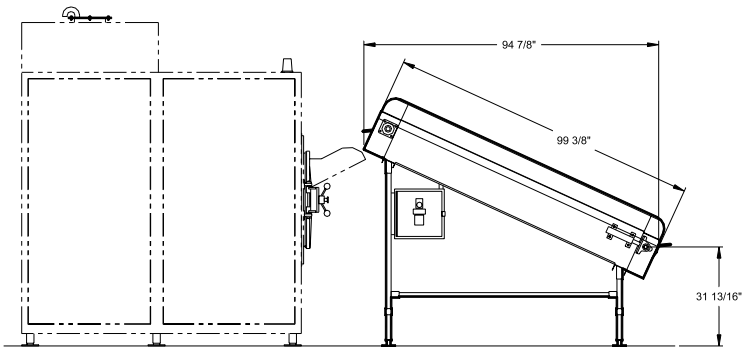

SIDE VIEW

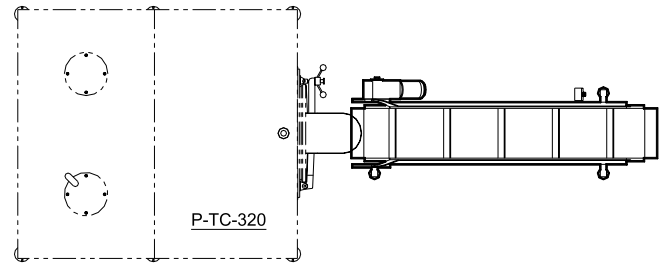

PLAN VIEW

CVY-320-S

**PIT CONVEYOR**

MODEL	ELECTRICAL
	⚡ 208V/ 3PH/60Hz
CVY-220S	3/4 HP – 5 AMPS
CVY-320S	3/4 HP – 5 AMPS
CVY-220	3/4 HP – 5 AMPS
CVY-320	3/4 HP – 5 AMPS

**NOTE:** CONVEYORS SHOWN ABOVE ARE FOR REFERENCE ONLY.  
SLOPE OF CONVEYOR IS DETERMINED ON SITE AND BASED  
ON PIT DEPTH AND THE EQUIPMENT LAYOUT.

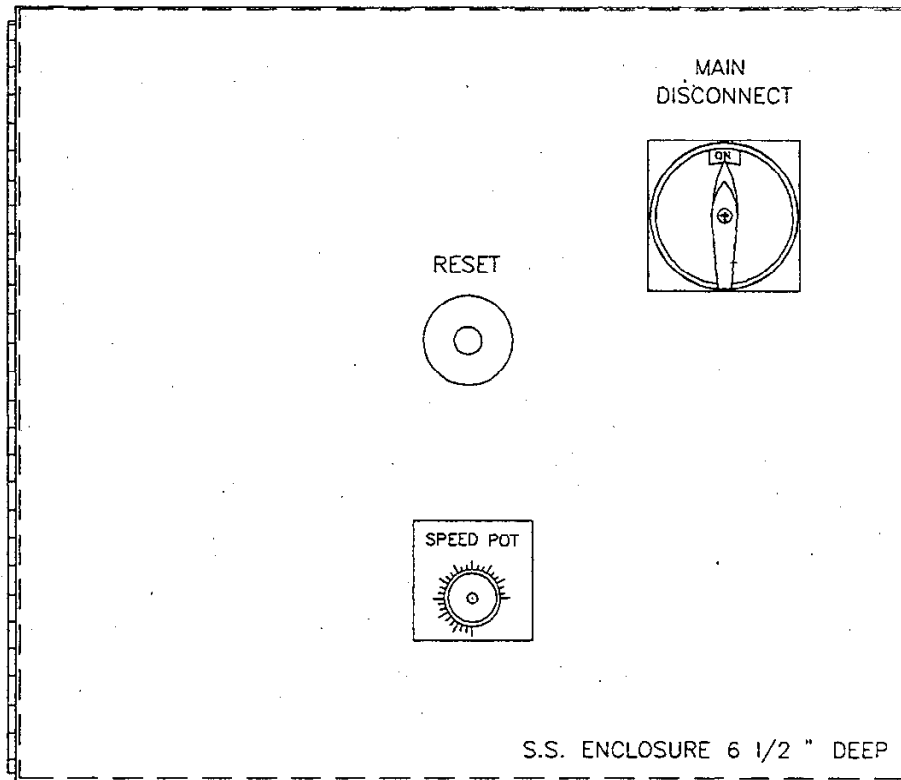

PANEL COVER

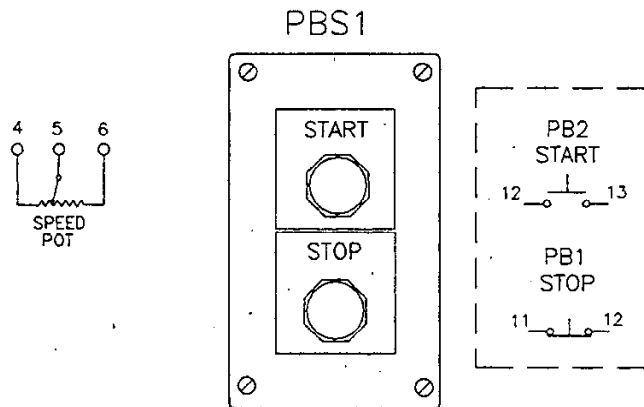

START/STOP P.B. STATION

(REFER TO CONVEYOR ASS.Y DWG.  
PLAN FOR EXACT LOCATION)

VETERANS HOME OF CALIFORNIA  
YOUNTVILLE, CALIFORNIA  
JOB NO. 97-101C

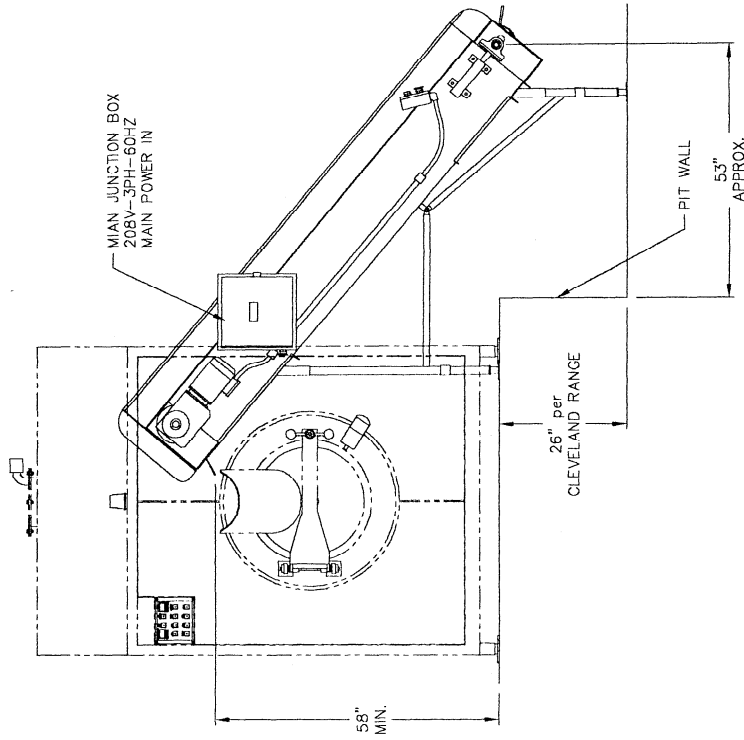
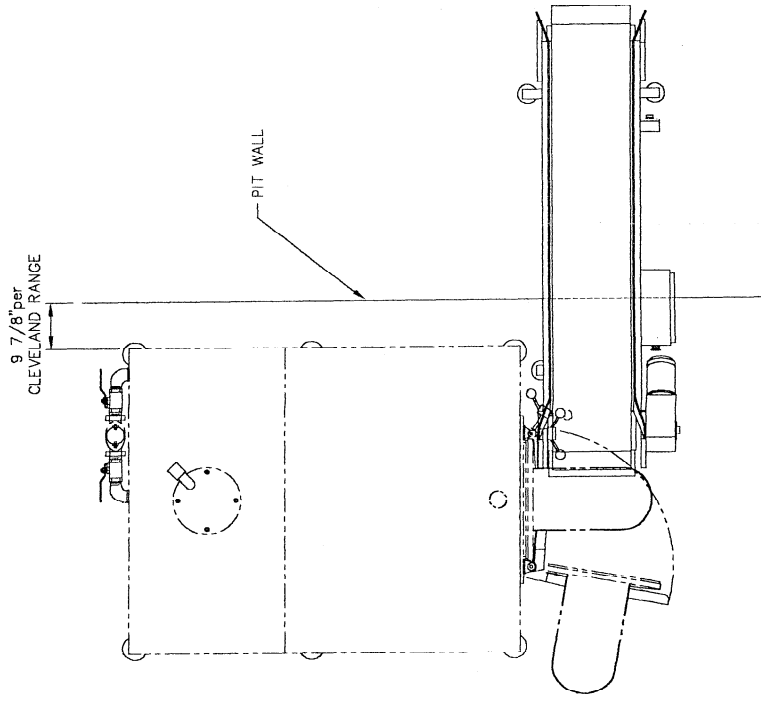

REV	DESCRIPTION	BY	DATE	<b>J.C.PARDO &amp; SONS INC.</b> 1250 REAMES RD. BALTO. MD. 21220 PHONE (410) 391-3600  FAX (410) 391-6042		DESIGNED BY: APPROVED BY:	DRAWN BY: JES DATE: 12/19/01 SCALE: NONE	CONVEYOR INSTALLATION AND UTILITY CONNS.	SHEET 9123	1 of 1
-----	-------------	----	------	--	--	------------------------------	--	---	---------------	--------

This drawing is an information only drawing. It is not intended to be used for construction. The contractor is responsible for verifying all dimensions and conditions on the job site. The contractor is responsible for obtaining all necessary permits and approvals. The contractor is responsible for ensuring that all work is done in accordance with all applicable codes and standards. The contractor is responsible for ensuring that all work is done in a safe and sound manner. The contractor is responsible for ensuring that all work is done in a timely and efficient manner. The contractor is responsible for ensuring that all work is done in a professional and courteous manner. The contractor is responsible for ensuring that all work is done in a high quality and reliable manner. The contractor is responsible for ensuring that all work is done in a cost-effective and efficient manner. The contractor is responsible for ensuring that all work is done in a safe and sound manner. The contractor is responsible for ensuring that all work is done in a timely and efficient manner. The contractor is responsible for ensuring that all work is done in a professional and courteous manner. The contractor is responsible for ensuring that all work is done in a high quality and reliable manner. The contractor is responsible for ensuring that all work is done in a cost-effective and efficient manner.

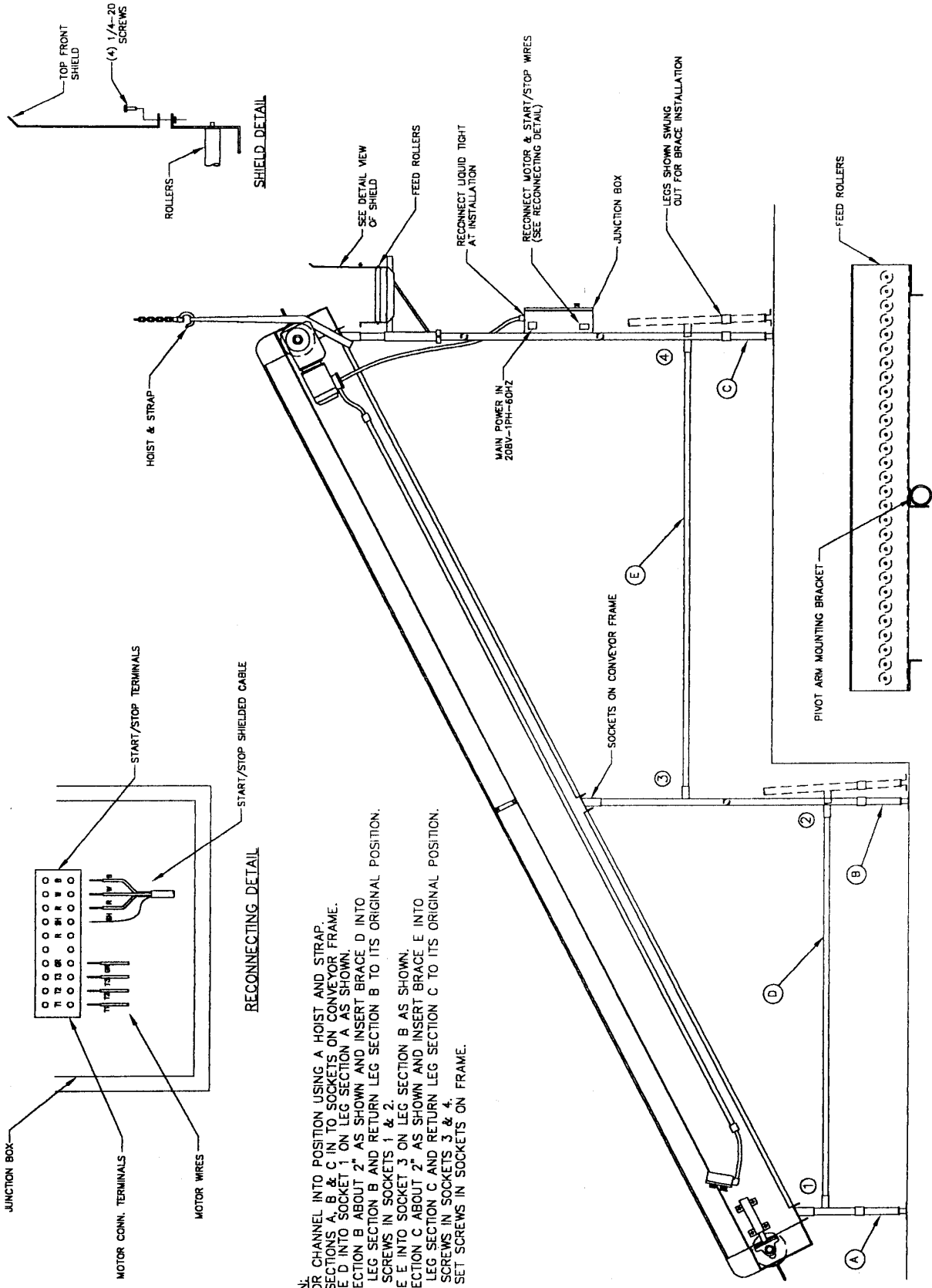

- LEG. INSTALLATION:**
1. LIFT CONVEYOR CHANNEL INTO POSITION USING A HOIST AND STRAP.
  2. INSERT LEG SECTIONS A, B & C INTO SOCKETS ON CONVEYOR FRAME.
  3. INSERT BRACE D INTO SOCKET 1 ON LEG SECTION A AS SHOWN.
  4. SWING LEG SECTION B ABOUT 2" AS SHOWN AND INSERT BRACE D INTO SOCKET 2 IN LEG SECTION B AND RETURN LEG SECTION B TO ITS ORIGINAL POSITION.
  5. TIGHTEN SET SCREWS IN SOCKETS 1 & 2.
  6. INSERT BRACE E INTO SOCKET 3 ON LEG SECTION B AS SHOWN.
  7. SWING LEG SECTION C ABOUT 2" AS SHOWN AND INSERT BRACE E INTO SOCKET 4 IN LEG SECTION C AND RETURN LEG SECTION C TO ITS ORIGINAL POSITION.
  8. TIGHTEN SET SCREWS IN SOCKETS 3 & 4.
  9. TIGHTEN ALL SET SCREWS IN SOCKETS ON FRAME.

FEED ROLLERS DETAIL

REV.	DESCRIPTION	BY	DATE	<b>J.C. PARDO &amp; SONS INC.</b> 1250 REAMES RD. BALTO MD. 21220 PHONE (410) 391-3800 FAX (410) 391-8043		DRAWING NUMBER <b>8930</b>
	REVISIONS			DRAWN BY: JES DATE: 8-24-99 SCALE: NONE	CHECKED BY: APPROVED BY:	SIZE: <b>C</b> SHEET: <b>1 of 1</b>
				<b>CVY-200/300 CONVEYOR INSTALLATION</b>		
<small>         This drawing is the property of J.C. Pardo &amp; Sons, Inc. and is not to be made public or used in any way without the written consent of J.C. Pardo &amp; Sons, Inc. All rights reserved.       </small>						

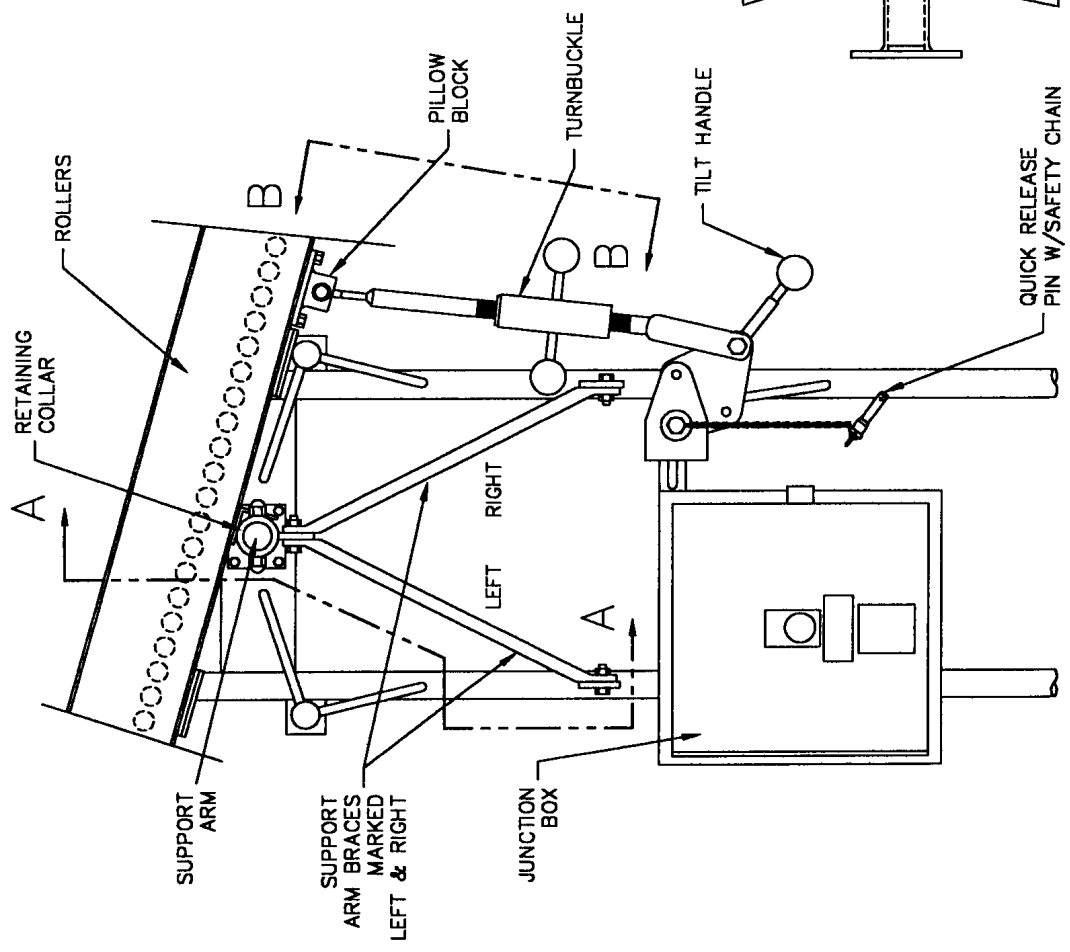
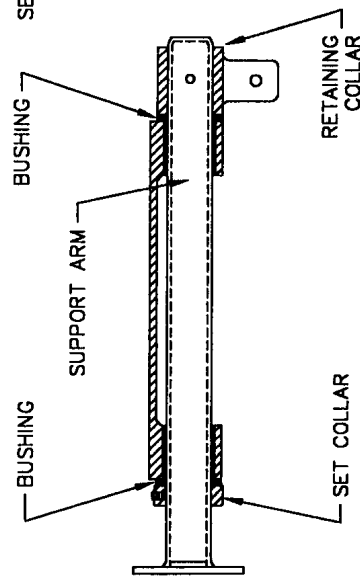
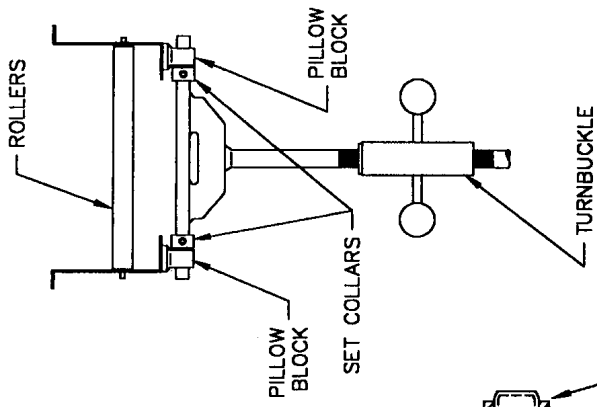
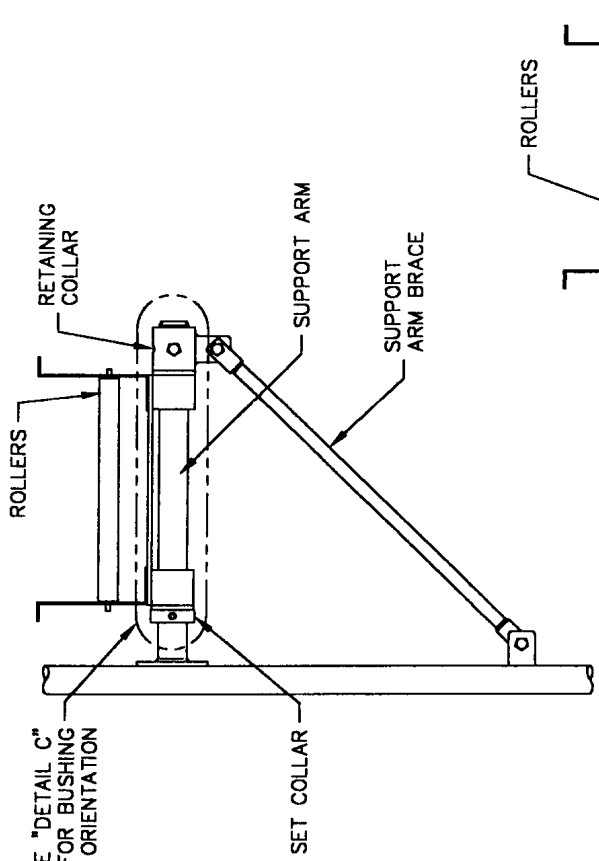

REV.	DESCRIPTION	BY	DATE	DESIGNED BY		CHECKED BY		DATE	SCALE	SHEET NO.	TOTAL SHEETS
				JAY S.	JAY S.	7-22-99	8918				
REVISIONS				<b>J.C. PARDO &amp; SONS INC.</b> 1260 REAMES RD. BALTO MD. 21220 PHONE (410) 861-8000 FAX (410) 861-9048							
				<b>FEED ROLLER TILTING MECHANISM ASSEMBLY</b> <small>THIS DRAWING IS THE PROPERTY OF J.C. PARDO &amp; SONS INC. IT IS TO BE USED ONLY FOR THE PROJECT AND QUANTITY SPECIFIED. IT IS NOT TO BE REPRODUCED OR TRANSMITTED IN ANY FORM OR BY ANY MEANS, ELECTRONIC OR MECHANICAL, INCLUDING PHOTOCOPYING, RECORDING, OR BY ANY INFORMATION STORAGE AND RETRIEVAL SYSTEM.</small>							

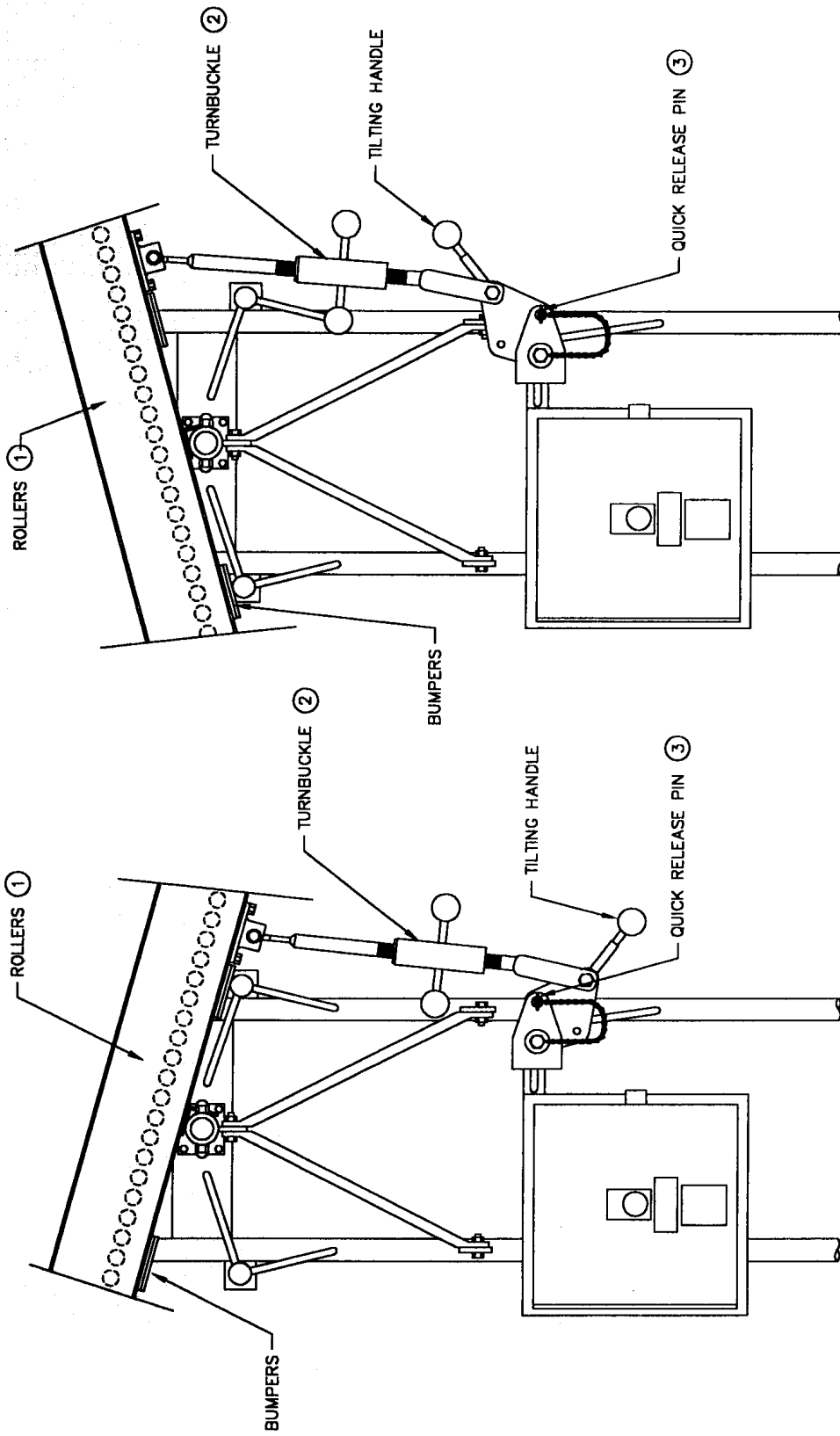

### POSITION A

FOR RIGHT SIDE CHILLER

### POSITION B

FOR LEFT SIDE CHILLER

TO TILT THE FEED ROLLERS ①, REMOVE THE TENSION ON THE ROLLERS USING THE TURNBUCKLE ②. REMOVE THE QUICK RELEASE PIN AND RAISE OR LOWER THE TILTING HANDLE AND REPLACE THE QUICK RELEASE PIN ③. ADJUST THE TURNBUCKLE TO PUT TENSION ON THE FEED ROLLERS SO THEY DO NOT BOUNCE AROUND DURING OPERATION. CAUTION: WHEN TILTING THE FEED ROLLERS TO POSITION A THE ROLLERS WILL WANT TO DROP. THIS WILL CAUSE DAMAGE TO THE ROLLER SECTION AND MAY INJURE SOMEONE STANDING NEAR THE END OF THE ROLLERS. ALWAYS MAINTAIN A GOOD HOLD ON THE TILTING HANDLE WHEN TILTING THE FEED ROLLERS.

REV.	DESCRIPTION	BY	DATE	<b>J.C.PARDO &amp; SONS INC.</b> 1250 REAMES RD. BALTO MD. 21220 PHONE (410) 981-8800 FAX (410) 981-9048		ORDER BY DATE IN JAY S. DATE 7-22-99 QUANTITY NONE	TILTING ROLLER OPERATION <small>THIS DRAWING IS THE PROPERTY OF J.C. PARDO &amp; SONS INC. IT IS TO BE USED ONLY FOR THE PURPOSES SPECIFIED HEREIN. IT IS NOT TO BE REPRODUCED OR TRANSMITTED IN ANY FORM OR BY ANY MEANS, ELECTRONIC OR MECHANICAL, INCLUDING PHOTOCOPYING, RECORDING, OR BY ANY INFORMATION STORAGE AND RETRIEVAL SYSTEM.</small>	DRAWING NUMBER <b>8919</b> SHEET
	REVISIONS							1 of 1

0011115

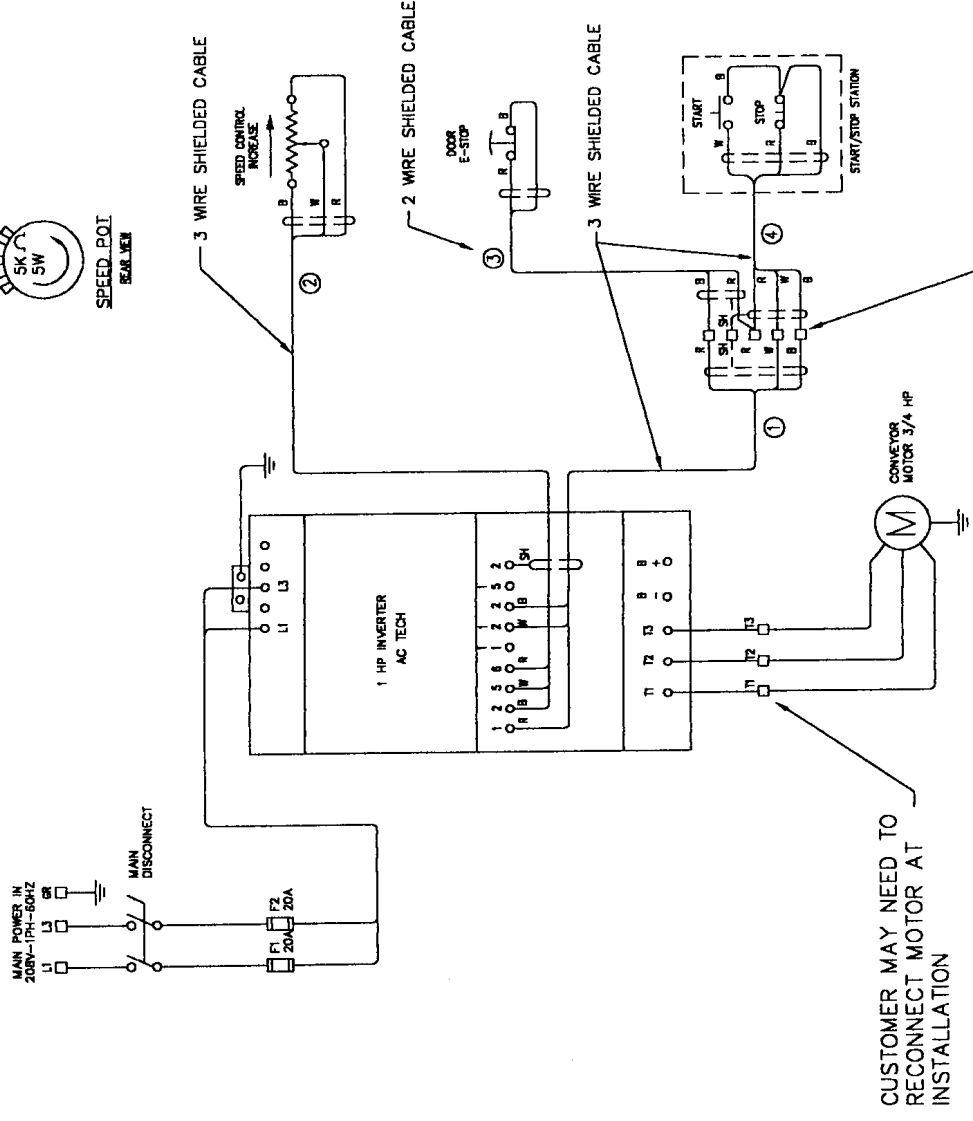
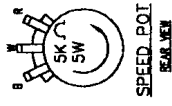
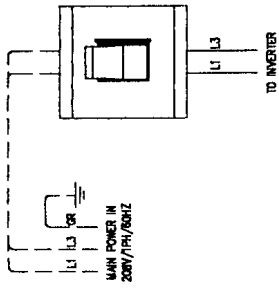

CUSTOMER MAY NEED TO RECONNECT START/STOP STATION AT INSTALLATION

CUSTOMER MAY NEED TO RECONNECT MOTOR AT INSTALLATION

FUSE NOTES:  
FUSES F1-F3 KTK-R RATED 600 VOLTS.

**J.C.PARDO & SONS INC.**  
1250 REAMES RD. BALTO MD. 21220  
PHONE (410) 381-3800 FAX (410) 381-9042

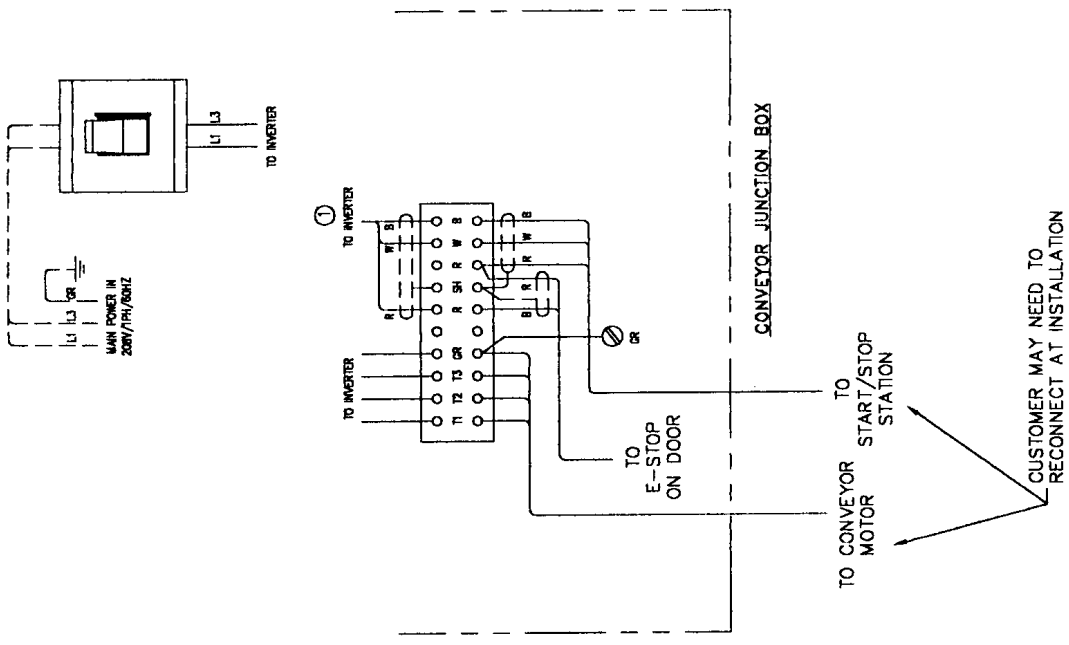

**ELECTRICAL SCHEMATIC CONVEYOR**  
**208V-1PH-60HZ**

REV.	DESCRIPTION	BY	DATE
	REVISIONS		

DESIGNED BY	DATE	SCALE
JES	2/7/02	NONE

DRIVER NUMBER	REV.
C	1 of 1

ES-0303
---------

This drawing and all information contained therein is the property of J.C.Pardo & Sons Inc. No part of this drawing may be reproduced or transmitted in any form or by any means, electronic or mechanical, including photocopying, recording, or by any information storage and retrieval system, without the prior written permission of J.C.Pardo & Sons.

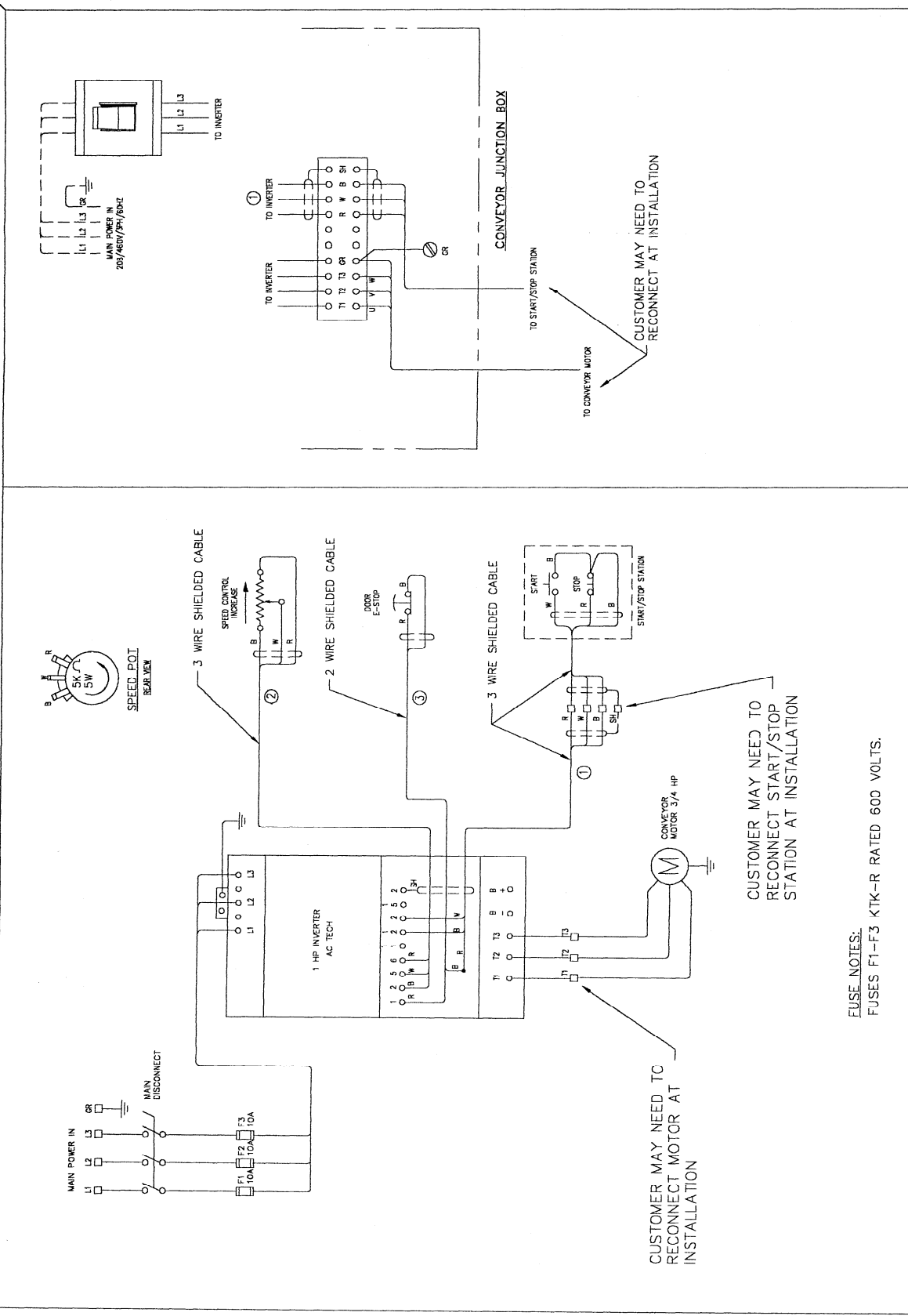

FUSE NOTES:  
FUSES F1-F3 KTK-R RATED 600 VOLTS.

REV. A	ADDED 208V & GEN. REV.	JES	12-01	DESCRIPTION	BY	DATE	REV. A	SIZE C	DRAWING NUMBER
REVISIONS							REV. A	SIZE C	ES-0236
<p><b>J.C. PARDO &amp; SONS INC.</b>          1350 REAMS RD.          BALTO. MD. 21220          PHONE (410) 381-8600          FAX (410) 381-8042</p>							<p><b>ELECTRICAL SCHEMATIC CONVEYOR</b>          208/450V-3PH-60HZ</p>		
<p><small>This drawing is the property of J.C. Pardo &amp; Sons Inc. It is to be used only for the project and location specified. No other use, reproduction, or distribution is permitted without the written consent of J.C. Pardo &amp; Sons Inc. The drawing is the property of J.C. Pardo &amp; Sons Inc. It is to be used only for the project and location specified. No other use, reproduction, or distribution is permitted without the written consent of J.C. Pardo &amp; Sons Inc.</small></p>									

NO.	PARAMETER NAME	RANGE OF ADJUSTMENT <i>Converter Program</i>	FACTORY DEFAULT (NOTE 1)	CUSTOMER SETTINGS
01	LINE VOLTAGE	HIGH (01), LOW (02)	HIGH (01)	02
02	CARRIER FREQUENCY	4kHz (01), 6 kHz (02), 8 kHz (03), 10 kHz (04)	6 kHz (02)	
03	START METHOD	NORMAL (01), START ON POWER UP (02), START WITH DC BRAKE (03), AUTO RESTART WITH DC BRAKE (04), FLYING RESTART 1 (05), FLYING RESTART 2 (06), FLYING RESTART 3 (07)	NORMAL (01)	01
04	STOP METHOD	COAST (01), COAST WITH DC BRAKE (02), FAMP (03), FAMP WITH DC BRAKE (04)	COAST (01)	03
05	STANDARD SPEED SOURCE	KEYPAD (01), PPRESET #1 (02), 0-10 VDC (03), 4-20 mA (04)	KEYPAD (01)	03
06	TE-14 OUTPUT	NONE (01), FUN (02), FAULT (03), INVERSE FAULT (04), FAULT LOCKOUT (05), AT SET SPEED (06), ABOVE PPRESET #3 (07), CURRENT LIMIT (08), AUTO SPEED (09), REVERSE (10)	NONE (01)	02
13	TE-15 OUTPUT		NONE (01)	
08	TE-30 OUTPUT	NONE (01), 0-10 VDC FREQ (02), 2-10 VDC FREQ (03), 0-10 VDC LOAD (04), 2-10 VDC LOAD (05)	NONE (01)	
09	TE-31 OUTPUT	NONE (01), 0-10 VDC LOAD (02), 2-10 VDC LOAD (03), DYNAMIC BRAKING (04)	NONE (01)	
10	TE-13A FUNCTION SELECT	NONE (01), 0-10 VDC (02), 4-20 mA (03), PRESET SPEED #1 (04), RUN REVERSE (05), START REVERSE (06), EXTERNAL FAULT (07), REMOTE KEYPAD (08), DS FAULT (09), AUXILIARY STOP (10), ACCEL/DECEL #2 (11)	NONE (01)	02
11	TE-13B FUNCTION SELECT	NONE (01), 0-10 VDC (02), 4-20 mA (03), PRESET SPEED #2 (04), DECREASE FREQ (05), JOG FORWARD (06), JOG REVERSE (07), AUXILIARY STOP (08)	NONE (01)	

NOTE 1: Factory defaults are shown for a 60 Hz base frequency. See Parameter 48 for 50 Hz base frequency.

**TO PROGRAM AC TECH INVERTER:**

1. PUSH MODE BUTTON 00 WILL APPEAR. W/ARROW KEY ENTER 22.5 PASSWORD.
2. PUSH MODE BUTTON TWO TIMES
3. PUSH ARROW KEY TO ENTER NEXT PARAMETER
4. PUSH MODE BUTTON ONCE
5. PUSH ARROW KEYS TO ENTER PARAMETER
6. REPEAT STEP 2 TO 5, FOR EACH SETTING
7. PUSH MODE BUTTON ONE TIME DASH LINES WILL DISPLAY. PROGRAM OK TO GO

PARAMETER MENU (CONTD)

NO.	PARAMETER NAME	RANGE OF ADJUSTMENT	FACTORY DEFAULT (NOTE 1)	
12	TB-13C FUNCTION SELECT	NONE (01), 0-10 VDC (02), 4-20 mA (03), PRESET SPEED #3 (04), INCREASE FREQ (05), EXTERNAL FAULT (06), REMOTE KEYPAD (07), DB FAULT (08), ACCEL/DECEL #2 (09)	NONE (01)	
13	TB-15 OUTPUT	(SEE PARAMETER 6 - TB-14 OUTPUT)	NONE (01)	02
14	CONTROL	TERMINAL STRIP ONLY (01), REMOTE KEYPAD ONLY (02), TERMINAL STRIP OR REMOTE KEYPAD (03)	TERMINAL STRIP ONLY (01)	
15	SERIAL LINK	DISABLE (01), 9600, 8, N, 2 WITH TIMER (02), 9600, 8, N, 2 WITHOUT TIMER (03), 9600, 8, E, 1 WITH TIMER (04), 9600, 8, E, 1 WITHOUT TIMER (05), 9600, 8, O, 1 WITH TIMER (06), 9600, 8, O, 1 WITHOUT TIMER (07)	9600, 8, N, 2 WITH TIMER (02)	
16	UNITS EDITING	TENTHS OF UNITS (01), WHOLE UNITS (02)	WHOLE UNITS (02)	
17	ROTATION	FORWARD ONLY (01), FORWARD AND REVERSE (02)	FORWARD ONLY (01)	
19	ACCELERATION TIME	0.1 - 3600.0 SEC	20.0 SEC	06
20	DECELERATION TIME	0.1 - 3600.0 SEC	20.0 SEC	01
21	DC BRAKE TIME	0.0 - 3600.0 SEC	0.0 SEC	
22	DC BRAKE VOLTAGE	0.0 - 30.0 %	0.0 %	
23	MINIMUM FREQUENCY	0.0 - MAXIMUM FREQUENCY	0.0 Hz	40
24	MAXIMUM FREQUENCY	MINIMUM FREQ - 240.0 Hz (NOTE 2)	60.0 Hz	60
25	CURRENT LIMIT	30 - 180 % (NOTE 3)	180%	
26	MOTOR OVERLOAD	30 - 100 %	100%	

NOTE 1: Factory defaults are shown for a 60 Hz base frequency. See Parameter 48 for 50 Hz base frequency.

NOTE 2: Maximum setting is 999.9 Hz on drives with High Output Frequency option. Consult the factory.

NOTE 3: If LINE VOLTAGE is set to LOW, maximum setting is 150%.

**PARAMETER MENU (CONTD)**

	<b>PARAMETER NAME</b>	<b>RANGE OF ADJUSTMENT</b>	<b>FACTORY DEFAULT (NOTE 1)</b>
	BASE FREQUENCY	25.0 - 500.0 Hz (NOTE 4)	60.0 Hz
	FIXED BOOST	0.0 - 30.0 %	1.0 %
	ACCEL BOOST	0.0 - 20.0 %	0.0 %
00	SLIP COMPENSATION	0.0 - 5.0 %	0.0 %
1-37	PRESET SPEEDS	0.0 - MAXIMUM FREQUENCY	0.0 Hz
38	SKIP BANDWIDTH	0.0 - 10.0 Hz	0.0 Hz
39	SPEED SCALING	0.0 - 6500.0	0.0
40	FREQUENCY SCALING	3.0 - 2000.0 Hz	60.0 Hz
41	LOAD SCALING	10 - 200 %	200 %
42	ACCEL / DECEL #2	0.1 - 3600.0 SEC	20.0 SEC
43	SERIAL ADDRESS	1 - 247	1
44	PASSWORD	000 - 999	225
47	CLEAR HISTORY	MAINTAIN (01), CLEAR (02)	MAINTAIN (01)
48	PROGRAM SELECTION	USER SETTINGS (01), OEM SETTINGS (02), RESET OEM (03), RESET 60 (04), RESET 50 (05)	USER SETTINGS (01)
50	FAULT HISTORY	(VIEW-ONLY)	(N/A)
51	SOFTWARE CODE	(VIEW-ONLY)	(N/A)
52	DC BUS VOLTAGE	(VIEW-ONLY)	(N/A)
53	MOTOR VOLTAGE	(VIEW-ONLY)	(N/A)
54	LOAD	(VIEW-ONLY)	(N/A)
55	0-10 VDC INPUT	(VIEW-ONLY)	(N/A)
56	4-20 mA INPUT	(VIEW-ONLY)	(N/A)
57	TB STRIP STATUS	(VIEW-ONLY)	(N/A)
58	KEYPAD STATUS	(VIEW-ONLY)	(N/A)
59	TB-30 OUTPUT	(VIEW-ONLY)	(N/A)
60	TB-31 OUTPUT	(VIEW-ONLY)	(N/A)

NOTE 1: Factory defaults are shown for a 60 Hz base frequency. See Parameter 48 for 50 Hz base frequency.

NOTE 4: Maximum setting is 1300.0 Hz (factory default is 999.9) on drives with High Output Frequency option. Consult the factory.

**BOOST SETTINGS DEPENDS ON LOADS: THIS UNIT HAS (2) BOOST SETTINGS. FIXED BOOST AND ACCEL BOOST. BOTH CAN BE ADJUSTED IF UNIT TRIPS OUT. MAKE ADJUSTMENT BY A FACTOR OF 1 UNTIL THE DRIVE WORKS CORRECTLY**

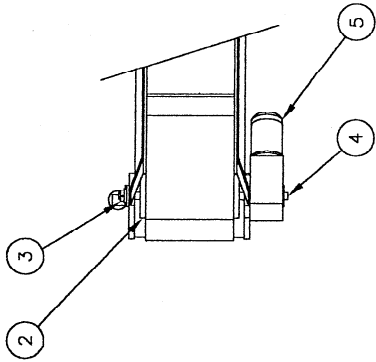

TOP VIEW

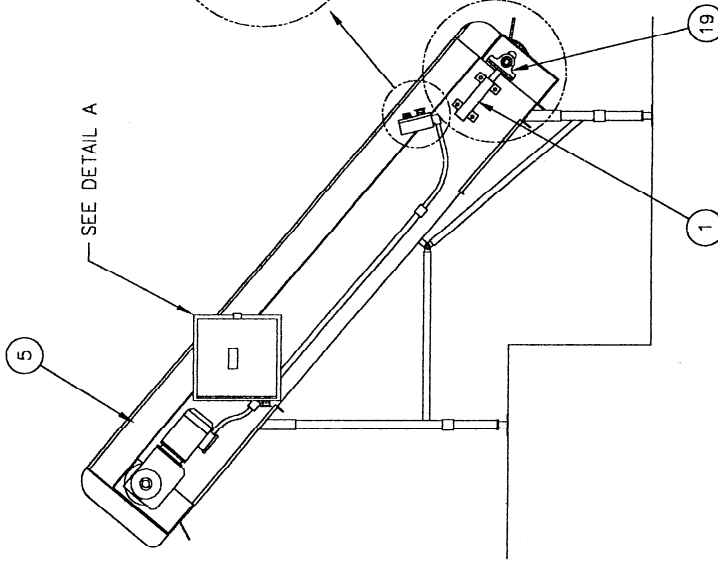

-SEE DETAIL A

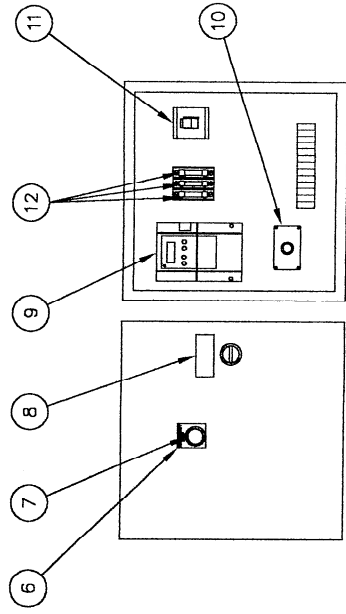

DETAIL A OUTSIDE

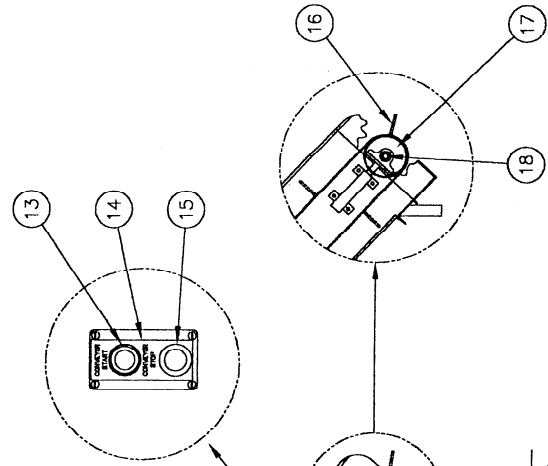

REV.	DESCRIPTION	BY	DATE	DESIGNED BY	DATE	APPROVED BY	DATE	REV.	REVISION NUMBER
	REVISIONS			JES	3/18/02	NONE		C	11651
<b>J.C. PARDO &amp; SONS INC.</b> 1260 REAMES RD. BALTO MD. 21220 PHONE (410) 391-8600 FAX (410) 391-9043								CVY-CASING CONVEYOR W/O ROLLERS REPLACEMENT PARTS <small>           This drawing is an interpretation developed through the Property            Rights in the design and must not be used for any other            purpose without the written consent of J.C. Pardo &amp; Sons, Inc.            directly or indirectly in any way.         </small>	
									1 of 2

REPLACEMENT PARTS		
ITEM	PART NO.	DESCRIPTION
1	MSS00-0000005	TELESCOPER
2	HWS00-0000006	LAGGING DRIVE PULLEY
3	BGC01-3800002	FLANGE FACE BEARING
4	1FS01-3800001	DRIVE SHAFT
5	DUH00-7500001	COMPLETE DRIVE UNIT 208V
-	DU900-7500001	REPLACEMENT MOTOR FOR ITEM #5
-	DU901-3800002	REPLACEMENT GEARBOX FOR ITEM #5
6	NPYELLOW00220	NAMEPLATE
7	2EP00-8800019	MUSHROOM STOP BUTTON
8	NPRED0000019	WARNING NAMEPLATE
9	ELHC1-0000003	1HP INVERTER 208V
10	2EP00-0000005	SPEED CONTROL UNIT
11	ELPSW-0000001	HIGH VOLTAGE DISCONNECT
12	ELV06-0000016	15 AMP FUSE
13	2EP01-25A0020	GREEN PUSH BUTTON
14	NPYELLOW00221	NAMEPLATE
15	2EP01-25A0014	RED MUSHROOM PUSH BUTTON
16	MSD16-0000012	CONVEYOR BELT
17	1WS00-0000007	IDLER PULLEY
18	1FS01-2500004	IDLER END SHAFT
19	EGC01-2500002	PILLOW BLOCK BEARING

REV. 1	DESCRIPTION	BY	DATE
	REVISIONS		
<b>J.C.PARDO &amp; SONS INC.</b> 1250 REAMES RD. BALTO MD. 21220 PHONE (410) 391-9600		DESIGNED BY APPROVED BY	DATE: 3/16/02 REAS: NONE
CVY- CASING CONVEYOR W/O ROLLERS REPLACEMENT PARTS		Dwg No: C Rev:	Drawing Number: 11651 Sheet: 2 of 2
<small>         This drawing is the property of J.C.Pardo &amp; Sons, Inc. and is not to be reproduced, copied, or transmitted in any form or by any means, electronic or mechanical, including photocopying, recording, or by any information storage and retrieval system, without the prior written permission of J.C.Pardo &amp; Sons, Inc.       </small>			

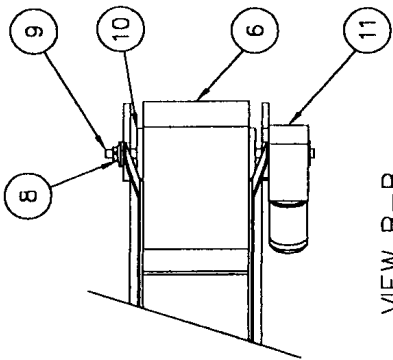

VIEW B-B

SEE DWG# 116ZZ FOR  
TILTING ARM PARTS

SEE DETAIL A

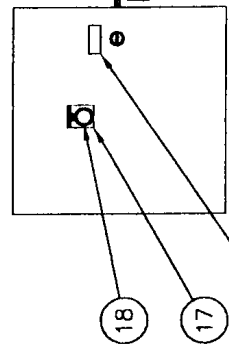
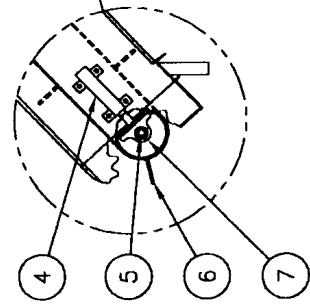
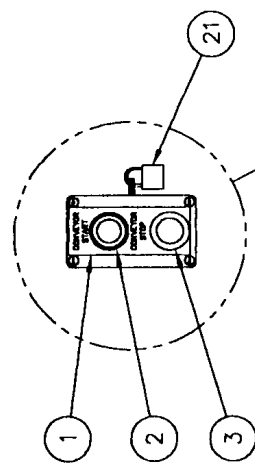

DETAIL A\_OUTSIDE

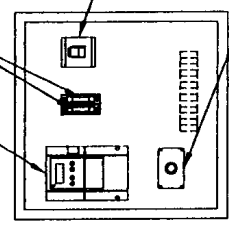

DETAIL A\_INSIDE

REV.:	DESCRIPTION	BY	DATE	<b>J.C.PARDO &amp; SONS INC.</b> 1250 REAMES RD. BALTO MD. 21220 PHONE (410) 981-8600 FAX (410) 981-8648		DRAWING NUMBER <b>11654</b>
				DESIGNED BY <b>JAY S.</b>	DATE <b>3/22/02</b>	SCALE <b>NONE</b>

DUAL TILT CONVEYOR (1 PH POWER IN)  
REPLACEMENT PARTS (MARCOPA ONLY)

This drawing is an illustration of a component. It is not intended to be used as a replacement part. It is the responsibility of the user to verify the part number and quantity of the part. The user should refer to the parts list for the correct part number and quantity.

REPLACEMENT PARTS	
ITEM	DESCRIPTION
1	NPYELLOW00221 FUNCTION TAG
2	2EP01-25A0020 GREEN PUSH BUTTON
3	2EP01-25A0014 RED MUSHROOM PUSH BUTTON
4	MSS00-0000005 TELESCOPE
5	1FS01-2500004 IDLER END SHAFT
6	MSD16-0000005 CONVEYOR BELT
7	BGC01-2500002 PILLOW BLOCK BEARING
8	BGC01-3800002 FLANGE FACE BEARING
9	1FS01-3800001 DRIVE SHAFT
10	HWS00-0000006 LAGGING DRIVE PULLEY
11	DUH00-7500001 COMPLETE DRIVE UNIT
-	DU900-7500001 REPLACEMENT MOTOR FOR ITEM #11
-	DU901-3800001 REPLACEMENT GEARBOX FOR ITEM #11
12	ELH01-0000001 INVERTER
13	ELV06-0000010 10 AMP FUZE
14	ELPSW-0000001 HIGH VOLTAGE DISCONNECT
15	2EP00-0000005 SPEED CONTROL UNIT
16	NPRED00000119 WARNING LABEL
17	NPYELLOW00220 FUNCTION TAG
18	2EP00-8800019 MUSHROOM STOP BUTTON
19	MSP01-1200001 ROLLERS
20	HWS00-0000007 IDLER PULLEY
21	HWLOCKS-00001 PADLOCK W/KEYS

DATE BY: JAY S.  
DATE: 3/22/02  
READ: NONE

ISSUED BY:  
APPROVED BY:

DUAL TILT CONVEYOR (1 PH POWER IN)  
REPLACEMENT PARTS (MARICOPA ONLY)

REV: C  
REV: 2 of 2

11654  
REV: C

1250 REALMS RD. BALTO MD. 21220  
PHONE (410) 381-8600 FAX (410) 381-8048

J.C.PARDO & SONS INC.

DESCRIPTION BY DATE  
REVISIONS

REVISIONS

REVISIONS

REVISIONS

REVISIONS

REVISIONS

REVISIONS

REVISIONS

REVISIONS

REVISIONS

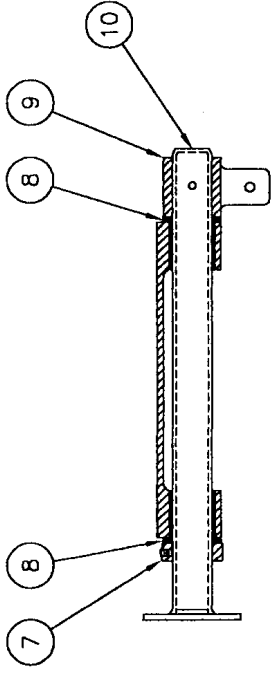
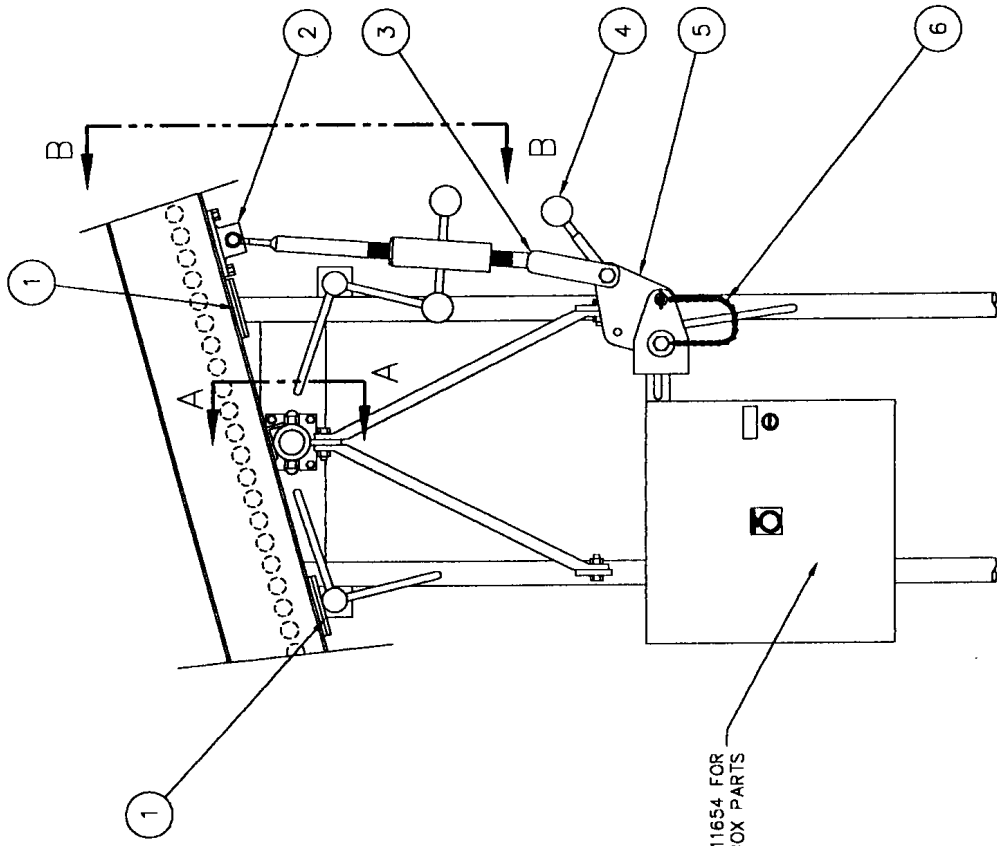

VIEW A-A

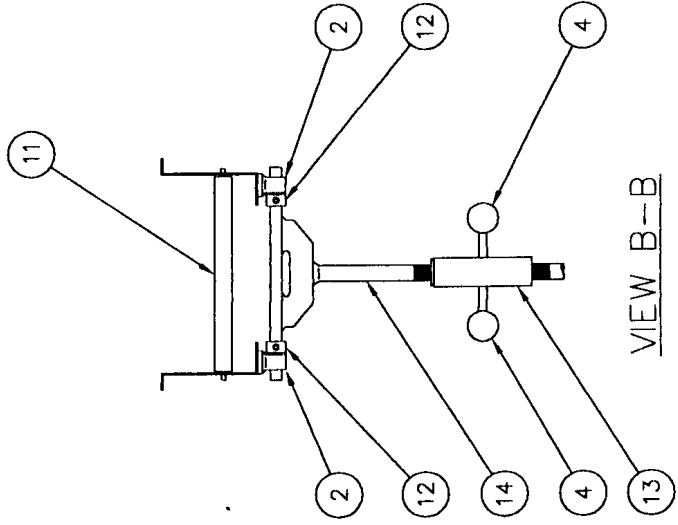

VIEW B-B

SEE DWG# 11654 FOR JUNCTION BOX PARTS

REV. DESCRIPTION		BY	DATE	REVISIONS	
<b>J.C.PARDO &amp; SONS INC.</b> 1250 REAMES RD. BALTO MD. 21220 PHONE (410) 381-3600 FAX (410) 381-0042				DESIGNED BY DATE 3/22/02 DRAWN BY JAY S.	CHECKED BY DATE NONE
DUAL TILT ROLLER WITH TURNBUCKLE REPLACEMENT PARTS (MARCOPA ONLY)				Dwg. No. 11655 C	Drawing Number 11655 SHEET 1 of 2

This drawing and all related information are the property of J.C. Pardo & Sons, Inc. and shall remain confidential. No part of this drawing may be reproduced or transmitted in any form or by any means, electronic or mechanical, including photocopying, recording, or by any information storage and retrieval system, without the prior written permission of J.C. Pardo & Sons, Inc.

REPLACEMENT PARTS		
ITEM	PART NO.	DESCRIPTION
1	MSD00-0000001	RUBBER PADS
2	1FS00-0000019	PILLOW BLOCK
-	BGZ00-7500015	REPLACEMENT BUSHING FOR ITEM #2
3	1FS01-0000008	LOWER TURNBUCKLE RODEND
4	MSP02-0000001	RED KNOB
5	1FS00-0000021	TILTING ARM
6	1HS00-000001	QUICK RELEASE PIN W/CHAIN
7	MSS01-6200001	SET COLLAR
8	1FA02-3800001	PIVOT ARM BUSHING
9	1FS02-0000018	SLEEVE
10	1FS01-2500005	PIVOT ARM
11	MSP01-1200001	ROLLERS
12	MSS00-7500005	SET COLLAR
13	1FS00-0000020	TURNBUCKLE BODY
14	1FS00-0000018	TOP TURNBUCKLE RODEND

REV. DESCRIPTION	BY	DATE	DATE BY JAY S.	DATE 3/22/02	SCALE NONE	QUANTITY	UNIT	PRICE	TOTAL
REVISIONS									
J.C.PARDO & SONS INC.			DUAL TILT ROLLER WITH TURNBUCKLE			C			
1250 REAMES RD.			REPLACEMENT PARTS (MARICOPA ONLY)			C			
PHONE (410) 361-3600			<small>           This drawing is the property of J.C.Pardo &amp; Sons. It is to be used for the manufacture of the product only and must not be made available to anyone else without the written consent of J.C.Pardo &amp; Sons.         </small>			11655			
BALTO MD. 21220						2 of 2			
FAX (410) 361-9042									

BILL OF MATERIAL

Project No. 97-101C

Bill of Material No.:

Project: VETERANS HOME OF CALIFORNIA

Date:

Item No.: F11

Equipment: CASING CONVEYOR

Page 1 of 1

Item Q'ty Part No. Description

1	1	CDP3320	1/4 HP BALDOR MOTOR T.E.F.C. 90 VOLT D.C.
2	1	75W THIN'N'TUFF	SPARKS BELT 14"X 26'w/ 2"CLEATS ON 18" CENTERS
3	1	NO. 7	SPARKS ST.STL. ALLIGATOR LACING
4	1	SD SERIES	CHANTLAND PULLEY TYPE D CROWNED 16" LONG 1" BORE NICKEL PLATED 6" DIA. ONE PIECE GUM ROUGHTOP LAGGING (AFTER PLATING)
5	1	SD SERIES	CHANTLAND PULLEY TYPE D CROWNED 16" LONG 1" BORE NICKEL PLATED 6" DIA.
6	1	SK-2	DRIVE SHAFT
7	1	SK-2	TAIL SHAFT
8	4		NICKEL PLATED 1" PILLOW BLOCK BEARINGS
9	1	HMQ1206	GROVE GEAR REDUCER 80:1 RATIO 22.5 R.P.M.
10	1	12178	GROVE HOLLOW TIE ROD KIT
11	1	12247	GROVE HOLLOW SHAFT BUSHING KIT FOR 1" SHAFT
12	2	"TELESCOPER"	250-6-SS-QR-BP-SF LOWMAN TAKE-UP
13			
14			
15			
16			
17			
18			
19			
20			
21			



## TROUBLE SHOOTING CHART

TROUBLE SYMPTONS:	CHECK POINTS:	CORRECTIVE ACTION:
Conveyor does not start ( Motors not running )	<ol style="list-style-type: none"> <li>1. Check disconnect switch on control panel cover.</li> <li>2. Check all fuses inside control panel.</li> <li>3. Check motor starter (ms1) inside panel.</li> <li>4. Check emergency kill switch, if one exists</li> <li>5. Check 208/120v transformer inside panel.</li> </ol>	<ol style="list-style-type: none"> <li>1. If switch is open, turn to close position.</li> <li>2. Replace any blown fuses.</li> <li>3. Replace starter if coil is open.</li> <li>4. Close emergency kill switch, if open. ( Pull out Red knob of switch )</li> <li>5. Replace if burned out or open.</li> </ol>
Conveyor does not start ( Motor is running )	<ol style="list-style-type: none"> <li>1. Check motor drive chain, &amp; sprocket.</li> <li>2. Check shear pin on motor if one exists.</li> <li>3. Check conveyor belt for breaks or slippage.</li> </ol>	<ol style="list-style-type: none"> <li>1. Repair broken link or tighten sprocket.</li> <li>2. Replace shear pin if broken.</li> <li>3. Repair belt if broken, tighten if loose.</li> </ol>
Conveyor stops running.	<ol style="list-style-type: none"> <li>1. Check motor overload.</li> <li>2. Check all fuses inside control panel.</li> <li>3. Check emergency kill switch if existing. Someone might have pushed in switch.</li> <li>4. Check 208/120v transformer inside panel.</li> </ol>	<ol style="list-style-type: none"> <li>1. Press Reset button on control panel cover. If motor still doesn't start, there can be a serious overload problem. Check load.</li> <li>2. Replace any blown fuses.</li> <li>3. Close emergency kill switch if open. (To do this , pull out Red knob of switch)</li> <li>4. Relace if burned out or open.</li> </ol>
Conveyor belt creeping off rollers	<ol style="list-style-type: none"> <li>1. Check Take up assembly located on sides of conveyor ( Bottom end )</li> </ol>	<ol style="list-style-type: none"> <li>1. Belt can be adjusted left or right by turning rods on either side of take up.</li> </ol>

## 4.2 TROUBLESHOOTING GUIDE      SCR CONTROLLER

SYMPTOM	PROBABLE CAUSE	CORRECTIVE ACTION
Control Blows Line Fuse F1	<ul style="list-style-type: none"> <li>• Shorted Power Module, Field Supply Diode (D19 or D20), or Suppressor (Z)</li> <li>• Controller or Motor Shorted to Ground</li> </ul>	<ul style="list-style-type: none"> <li>• Replace Faulty Component</li> <li>• Check for Short and Repair as Required</li> </ul>
Control will not START	<ul style="list-style-type: none"> <li>• Blown Fuse (F1)</li> <li>• Defective Power Module</li> <li>• Defective Component on Control Board</li> <li>• Jumper missing from TB2-7 to TB2-8 (speed control) or TB2-4 to TB2-5 (Torque Control)</li> </ul>	<ul style="list-style-type: none"> <li>• Replace Fuse</li> <li>• Replace Faulty Component</li> <li>• Replace Faulty Component</li> <li>• Replace Jumper on Terminal Strip</li> </ul>
Motor will not come up to speed	<ul style="list-style-type: none"> <li>• Max. speed adjust, R27 is set too low</li> <li>• Motor overloaded</li> <li>• Torque adjust, R29 is set too low</li> <li>• Current Programming Jumper J1 in wrong position</li> <li>• Defective Power Module</li> <li>• Defective Component on Control Board</li> </ul>	<ul style="list-style-type: none"> <li>• Re-adjust R27 for correct Top Speed</li> <li>• Check load and adjust as required</li> <li>• Re-adjust R29 for increased motor current</li> <li>• Re-locate Jumper position for correct current range</li> <li>• Replace Faulty Component</li> <li>• Replace Faulty Component</li> </ul>
Motor will not stop with Speed Adjust pot at zero speed	<ul style="list-style-type: none"> <li>• Min. Speed, R28, is set too high</li> <li>• Defective Speed Adjust pot</li> <li>• SW1 in Tach. Position</li> <li>• Tach generator polarity is incorrect</li> <li>• Defective Power Module</li> <li>• Defective Component on Control Board</li> </ul>	<ul style="list-style-type: none"> <li>• Re-adjust R28 for correct min. speed when reference is at the minimum value</li> <li>• Replace Faulty Component</li> <li>• Select Arm Position</li> <li>• Reverse tach generator leads</li> <li>• Replace Faulty Component</li> <li>• Replace Faulty Component</li> </ul>
Motor speed is unstable or Pulsates	<ul style="list-style-type: none"> <li>• IR Comp. Adjust Pot. R26, is set too high (Armature Feedback only)</li> <li>• Motor is being Overhauled</li> <li>• Defective Motor</li> <li>• Defective Component on Control Board</li> <li>• Defective or Intermittent Tach Generator</li> </ul>	<ul style="list-style-type: none"> <li>• Re-adjust R26 per 3.3.8</li> <li>• Check Load for Correct Operation</li> <li>• Repair or Replace Motor</li> <li>• Replace Faulty Component</li> <li>• Replace Tach Generator</li> </ul>
Motor will not Maintain Speed Under Load	<ul style="list-style-type: none"> <li>• IR Comp. Adjust Pot R26 is set Too Low (Armature Feedback only)</li> <li>• Torque set too low</li> <li>• Motor Over Loaded</li> <li>• Defective Component on Control Board</li> <li>• Defective Power Module</li> </ul>	<ul style="list-style-type: none"> <li>• Re-adjust R26 3.3.8</li> <li>• Adjust Torque Pot</li> <li>• Check Load for Correct Operation</li> <li>• Replace Faulty Component</li> <li>• Replace Faulty Component</li> </ul>