

Installation, Use and Care Instructions Convection Pro XVI

INSTALLATION

INSTALLATION SAFETY

WARNING

Installation of this equipment must be accomplished by qualified installation personnel, working to all applicable local and national codes. Improper installation of this product could cause injury or damage.

DO NOT store or use gasoline or other flammable vapors and liquids in the vicinity of this or any other appliance.

The flooring that will be directly under the boiler must also be made of a noncombustible material.

Cleveland Range equipment is designed and built to comply with applicable standards for manufacturers. Included among those certification agencies which have approved the safety of the equipment design and construction are: UL, A.G.A., NSF, ASME, CSA, CGA, and others.

Cleveland Range equipment is designed and certified for safe operation only when permanently installed in accordance with local and/or national codes. Many local codes exist and it is the responsibility of the owner and installer to comply with these codes.

In no event shall Cleveland Range assume any liability for consequential damage or injury resulting from installations which are not in strict compliance with our installation instructions. Specifically, Cleveland Range will not assume any liability for damage or injury resulting from improper installation of equipment, including, but not limited to, temporary or mobile installations.

INSTALLATION INSTRUCTIONS

1. These instructions must be retained by the owner/user for future reference. Gas-fired boilers are only to be installed in noncombustible areas that have provisions for adequate air supply. The term "boiler" will be used synonymously with "steam generator".
2. Position: For proper operation and drainage, the equipment must be level. It should be placed next to an open floor drain. **DO NOT POSITION THE UNIT DIRECTLY ABOVE THE FLOOR DRAIN.** Observe all clearance requirements to provide air supply for proper operation, as well as sufficient clearance for servicing. The surrounding area must be free and clear of combustibles. Dimensions and clearance specifications are shown on the specification sheet.
3. Install in accordance with local codes and/or the National Electric Code ANSI/NFPA No. 70-1987. Installation in Canada must be in accordance with the Canadian Electrical Code CSA Standard C22.1. Equipment that is con-

nected to electricity must be grounded by the installer. A wiring diagram is provided inside the base cabinet.

WARNING

INJURY TO PERSONNEL AND EQUIPMENT DAMAGE may result from an improper drain connection.

4. The drain line outlet discharges exhaust steam and hot condensate. Connect 1-1/2-inch IPS piping (or larger) to extend the drain line to a nearby open floor drain. Up to two elbows and six feet of 1-1/2-inch IPS (or larger) extension pipe should be connected to the drain termination. Drain piping extended six to twelve feet, or using three elbows, should be increased to 2-inch IPS. No more than two pieces of Cleveland Range equipment should be connected to one common drain line. The maximum length of extension from the drain termination should not exceed six feet and use no more than two elbows. The extension piping must have a gravity flow and vent freely to the air. This drain outlet must be free-vented to avoid the creation of back pressure in the steamer cooking compartments. To ensure a vented drain line, **DO NOT, UNDER ANY CIRCUMSTANCES, CONNECT THE DRAIN OUTLET DIRECTLY TO THE FLOOR DRAIN OR SEWER LINE.** Do not run the drain line discharge into PVC drain piping or any other drain piping material not capable of sustaining 180°F operation.

NOTE: Direct-steam connected pressure steamers do not require a cold water connection, and therefore steps 5 and 6 do not apply. Refer directly to step 7. A kettle fill faucet, if so equipped, requires a hot and/or cold water connection. The data contained in step 5 for cold water also applies to hot water.

5. Connect COLD water supply plumbing to the line strainer. (Never connect hot water to the boiler water fill line strainer.) Constant flow pressure must be maintained between 35 and 60 psi, and not experience a pressure drop below 35 psi when other appliances are used. If the water pressure exceeds 60 psi, a pressure reducing valve must be installed in the water supply plumbing to reduce the water pressure to less than 60 psi. Locations and pressure data are shown on the specification sheet. 1/4-inch IPS plumbing is sufficient for water supply lines up to 20 feet in length, but water supply lines longer than 20 feet should be at least 3/8-inch IPS. Flush water supply lines thoroughly before connecting them to the unit. Use water which is low in total dissolved solids content and low in gas content to prevent internal scaling, pitting and corrosion of the steam generator, and carry-over of minerals into the steam. Water which is fit to drink can still contain highly detrimental impurities.

NOTE: If equipped with a kettle and kettle water fill swing spout, 3/8-inch (10mm) hot and/or cold water connection(s) will be required at the swing spout valve.

6. Turn on the cold water supply to the unit. Ensure that the manual water valve, inside the base cabinet, is open.

Installation, Use and Care Instructions

Convection Pro XVI

7. Connect the primary fuel supply in accordance with the following instructions. Location and other data are shown on the specification sheet.

For Gas-Fired Steam Generators: Post in a prominent location, instructions to be followed in the event the user smells gas. This information shall be obtained by consulting the local gas supplier. Install a sediment trap (drip leg) in the gas supply line, then connect gas supply piping to the boiler gas valve piping. **GAS-FIRED EQUIPMENT IS DESIGNED FOR INSTALLATION ONLY IN NON-COMBUSTIBLE LOCATIONS. THIS INCLUDES THE FLOORING THAT WILL BE DIRECTLY UNDER THE EQUIPMENT.** Location, plumbing size, and pressure data are shown on the specification sheet. Boilers rated at less than 225,000 BTU require 3/4-inch IPS gas supply piping, and boilers rated at 225,000 BTU or more require 1-inch IPS gas supply piping. Natural gas pressure must be between 4" - 14" water column, and L.P. gas supply pressure must be between 12" - 14" water column. **NEVER EXCEED 14" WATER COLUMN (1/2 psi) GAS PRESSURE.** If the gas supply pressure exceeds 14" water column, a pressure regulating valve must be installed in the gas supply plumbing to reduce the gas pressure to less than 14" water column. Installation must be in accordance with local codes, or in the absence of local codes, with the National Fuel Gas Code, ANSI Z223.1-1984. Installation in Canada must be in accordance with installation codes for Gas Burning Appliances and Equipment B149.1 and B149.2 Use a gas pipe joint compound which is resistant to LP gas. Turn the gas valve control knob to ON (the word "on" on the knob will be opposite the index on the valve's body). Test all pipe joints for leaks with soap and water solution. Never obstruct the flow of combustion and ventilation air. Observe all clearance requirements to provide adequate air openings into the combustion chamber. The appliance and its individual shut-off valve must be disconnected from the gas supply piping system during any pressure testing of that system at test pressures in excess of 14" water column (1/2 psi or 3.45 kPa). The appliance must be isolated from the gas supply piping system at test pressures equal to or less than 14" water column (1/2 psi or 3.45 kPa). A permanent 115 volt electrical connection is required at the junction box. The junction box location is shown on the specification sheet. The unit must be electrically grounded by the installer.

For Electric-Powered Steam Generators: Connect electric power: location and data are shown on the specification sheet. Provide connection as required by the unit; either directly to the single contactor, or to the terminal block (when equipped with multiple contactors). Electric supply must match power requirements specified on the data plate inside the base cabinet. The copper wiring must be adequate to carry the required current at the rated voltage. A separate fused disconnect switch must be supplied and installed. The unit must be electrically grounded by the installer.

For Steam Coil Steam Generators: Connect steam supply piping to the input side of the steam coil. Location and pressure data are shown on the specification sheet. Incoming steam pressure must be regulated between 35 and 45 psi. A 3/4-inch strainer, equipped with a 20 mesh stainless steel screen, must be supplied and installed at the incoming steam connection point. Flush the steam line thoroughly before connecting it to the boiler. To ensure an adequate volume of steam, the branch steam supply line must be 3/4-inch IPS minimum. Connect the inverted bucket trap to the outlet end of the steam coil. Fill the trap with water before installing it. A permanent 115 volt electrical connection is required at the junction box. The junction box location is shown on the specification sheet. The unit must be electrically grounded by the installer.

For Direct-Steam Connected Steamers/Kettles: Connect steam supply piping to the input side of the line strainer. Location and pressure data are shown on the specification sheet. Flush the steam line thoroughly before connecting it to the steamer. To ensure an adequate volume of steam, the branch steam supply line must be 3/4-inch IPS minimum. (Direct-steam-connected kettles require 1/2-inch IPS pipe if the kettle total capacity is 20 gallons or less, and 3/4-inch IPS pipe if the total capacity exceeds 20 gallons.) A permanent 115 volt electrical connection is required at the junction box. The junction box location is shown on the specification sheet. The unit must be electrically grounded by the installer.

Installation Checks

Proper operation of the Cleveland Convection Pro XVI steamer is dependent upon proper installation. After the steamer has been installed, a few quick checks could save unnecessary service calls.

1. The unit must be level.
2. The Convection Pro XVI steamer requires a cold water connection for proper, efficient operation. **DO NOT USE HOT WATER.** The cold water must be connected to the line strainer, located at the front lower-right of the steamer base.
3. Check that the manual water supply valve is open.
4. Check all water supply lines and valves for leaks.
5. Check that the water supply pressure and water quality meet the requirements of installation paragraph 5.
6. On electric units, verify that the supply voltage meets the voltage requirements on the rating plate inside the base cabinet, and the voltage shown on the packing slip. Verify that the unit is protected with a separate fused disconnect, and is properly grounded in accordance with the National Electric Code.
7. On gas, steam coil, and direct-steam-connected units, verify that there is a 115 Volt connection at the handi-box located on the left side of the base at the bottom front.

Installation, Use and Care Instructions Convection Pro XVI

8. On steam coil units, the incoming steam pressure must be 35 to 50 psi. Less than 35 psi will not effectively operate the unit. Pressure in excess of 50 psi must be reduced (with a pressure reducing valve) to 35 to 50 psi.

WARNING
INJURY TO PERSONNEL AND EQUIPMENT DAMAGE
may result from an improper drain connection.

9. Check that the drain lines meet the installation requirements specified in installation paragraph 4.
10. After completing checks 1 through 9, and correcting any deficiencies, refer to the Start-up and Preheat instructions in the Operation section. Verify that the unit operates properly, and make checks 11 and 12.
11. Check to ensure that the water in the boiler sight gage glass automatically stays about 1/3 full when the boiler is started up and operated.
12. Check to ensure that the steam pressure gage registers 10 psi.

The steam pressure is factory-adjusted to provide the proper pressure. In some cases, however, the factory setting may shift due to shaking in transit, and resetting will be required after installation. Proper adjustments and maintenance procedures are detailed on separate data sheet entitled "Steam Pressure Adjustments." Adjustments should be made only by qualified service personnel. The factory pressure settings shown in the accompanying chart should never be exceeded.

Gage Pressure Reading with No Steam Flow* (Static Pressure)

Self-Contained Steam Generator, Gas or Electric

Operating Pressure Switch	10 psi
High Limit Safety Pressure Switch	15 psi

Self-Contained Steam Coil Generator

Operating Pressure Switch	10 psi
High Limit Safety Pressure Switch	15 psi
Steam Supply Pressure Range	35-45 psi

Direct-Connect (to House Steam Supply)

Steamer Pressure Reducing Valve	10 psi
Steam Supply Pressure Range	15-45 psi

*with or without kettle

OPERATION

Operation of the Cleveland Range Convection Pro XVI steamer is very easy. Each operator should read and understand the following procedures to effectively start, operate, and shut down the steamer each day. The owner(s) and operator(s) of this equipment should be aware that live steam can cause serious injuries, and pay particular attention to the WARNINGS in this text. These instructions are to be retained by the owner(s) and operator(s) for future reference.

Controls and Control Panels

There are two steam generator control arrangements and two steamer compartment control panels available for Cleveland Range Convection Pro XVI steamers. The steam generator controls are illustrated in Figure 1. The steamer compartment control panels are illustrated in Figures 2 and 3. Compare these figures with the equipment supplied, and identify which control and panel combinations apply.

Steam Generator Controls

The steam generator controls are located on the front face of the steamer base unit. The switches are to the left of the pressure gage, as illustrated in Figure 1. Most Cleveland Range Convection Pro XVI steamers have a steam generator built into the base unit which supplies steam to the cooking compartments. However, an external steam supply may also be used. Units with a built-in boiler have both the POWER rocker switch and the STEAM momentary switch next to the pressure gage. Units with an external steam supply have the POWER rocker switch only. They do not have the STEAM momentary switch.

Steamer Compartment Control Panels

Figure 2 illustrates the standard electronic controls: the Key Pad Control Panel. This panel has a rocker switch, a key pad, and a digital timer. Figure 3 illustrates the optional electro-mechanical controls: the Dial Timer Control Panel. This panel has a rocker switch and dial timer. Steamer functions are the same for both the standard and optional panel configurations. Operating details are slightly different especially when setting the automatic operating time. For clarity, two sets of instructions are provided for cooking operations.

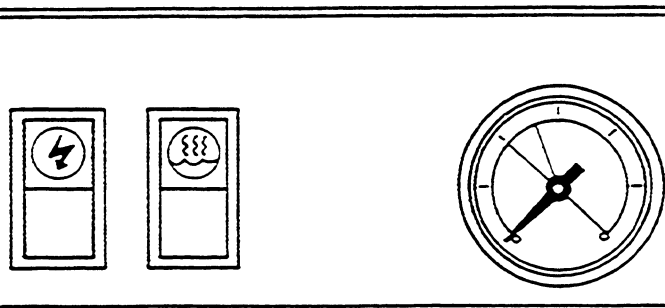

Figure 1. Steam Generator Controls

Installation, Use and Care Instructions Convection Pro XVI

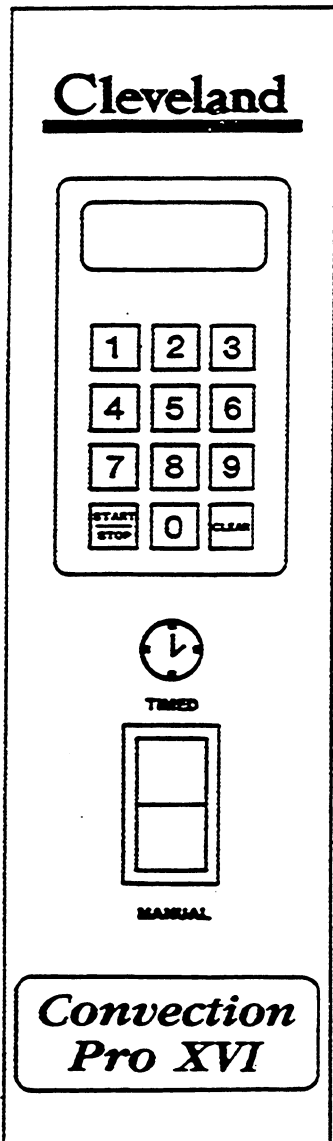

Figure 2. Key Pad Control Panel

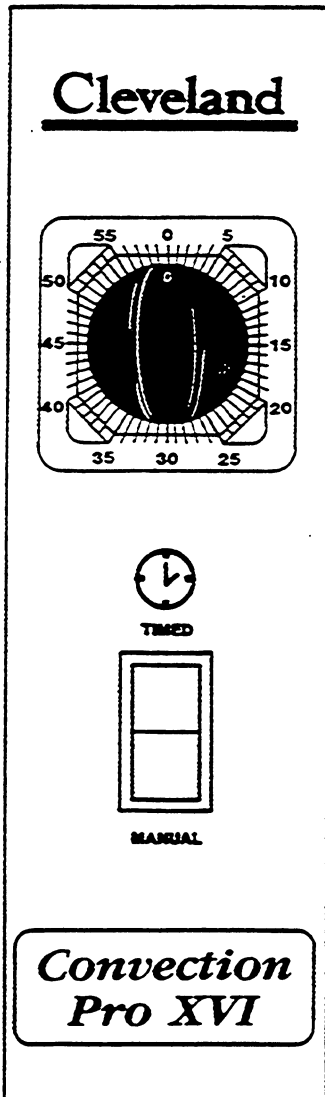

Figure 3. Dial Timer Control Panel

2. Start the steam supply. The steam supply is either an integral steam generator (boiler) built into the base unit, or an external steam supply.
 - For units without a built-in boiler, refer to the start-up procedures for the external steam supply and be sure it is running properly. As soon as the pressure gage on the Convection Pro XVI Steamer registers 10 psi, steamer preheating may begin. Skip the remainder of step 2, and begin step 3, preheat instructions.
 - For units with a built-in boiler, fill the boiler with water and start the steam generator as described in steps a. through d. below.
 - a. Press the ON end of the POWER on-off rocker switch located next to the steam pressure gage (Figure 1). The red indicator light in the POWER rocker switch turns on and the steam generator begins to fill with water. This takes about 5 minutes.
 - b. When the water level in the steam generator reaches a safe operating level, the amber light in the STEAM momentary switch turns on. Whenever the amber light is on, the heaters, steam supply, or burners are off, and no steam is being generated. The energy source (electric, gas, etc.) cannot be activated until the boiler contains sufficient water, indicated by the amber light.
 - c. Press the STEAM momentary switch to produce steam in the boiler. This activates the energy source (electric heaters, gas burners, or steam solenoid valve) and the amber light turns off.

The STEAM switch must be pressed to re-start the steamer after it is shut off for any reason (including a brief power interruption). No attempt should be made to operate the equipment during a power failure.

NOTE: For steamers with built-in gas-fired boilers: If the burners fail to ignite in four seconds, a safety circuit de-energizes the system. In this event, toggle the POWER rocker switch to the OFF position and back to the ON position. The amber light in the STEAM momentary switch lights. Wait five minutes, then press the STEAM momentary switch to start the burner ignition cycle once again.

- d. About 20 minutes after starting the boiler in step c, the steam pressure gage on the unit base should register 10 psi.
3. Preheat the Convection Pro XVI steamer cooking compartments. For accurate, efficient cooking times, the cooking compartments should be preheated during startup.
 - a. Close the compartment door by gently swinging it shut.
 - b. Refer to timer setting instructions under Automatic Operation for the appropriate control panel. Set the timer for each compartment to one minute, and start the cooking cycles. Steaming begins in each compartment.

Start-up and Preheat

WARNING

Do not attempt to start or operate the Convection Pro XVI steamer during a power failure. Critical safety circuits are not energized, and serious injury to personnel or damage to equipment may result.

1. Inspect the steamer. Check the cooking compartments to ensure that the steam tubes and drain screens are in place and secure. Check inside the steamer base cabinet to ensure that the manual drain valve is closed and the manual water supply valve is open.

Installation, Use and Care Instructions

Convection Pro XVI

NOTE: On Convection Pro XVI steamers equipped with the electronic key pad control panels, the timer does not begin counting down until the cooking compartment reaches operating temperature. This may take 2 or 3 minutes if the steamer has not been operating.

- c. Steaming continues for the set one minute. When the preheating is completed, the steam automatically shuts off and a 3-second alarm sounds. The Convection Pro XVI steamer is ready for cooking operations.

COOKING OPERATIONS

The control panels mounted on the cooking compartments regulate cooking operations. Although cooking operations are similar for all Convection Pro Steamers, regardless of control panel configuration, separate instructions are provided for each control panel type.

Cooking Operations for The Key Pad Control Panel

The electronic key pad control panel is illustrated in Figure 2.

The Cleveland Range Convection Pro XVI steamer has two cooking modes: Manual and Automatic. The Manual Mode provides continuous steaming and is turned on and off by the MANUAL/TIMED rocker switch. The Automatic Mode monitors cooking time and compartment temperature to provide accurate, efficient, uniform steam cooking.

NOTE: Whether using timed or manual cooking modes, optimum steam heat transfer, and therefore a higher quality food product, is achieved when shallow, perforated, uncovered pans are used.

WARNING

LIVE STEAM may cause severe burns. Use extreme caution when opening the steamer door. Turn face away from the steamer when first opening the door. Do not look into the cooking compartment until steam has cleared. **KEEP HANDS OUT OF THE COOKING COMPARTMENT TO PREVENT BURNS.**

Manual Cooking Operation - Key Pad Controls

Use manual mode for a continuous supply of steam for long periods, or if the required cooking time is unknown and frequent inspection is required.

1. Place the pan(s) of food into the cooking compartment.
2. To START the flow of steam, press the MANUAL end of the MANUAL/TIMED rocker switch, located below the timer. Steam immediately starts flowing into the cooking compartment.
3. If food inspection is required during steaming, refer to the LIVE STEAM WARNING above. Use extreme caution when opening the steamer door during steaming operations.

4. Although the timer can not turn the steam off in manual mode, it can be used as a conventional cooking timer. Refer to the timer setting instructions under Automatic Operation and set the timer. The timer will count down the set period and sound the buzzer, but IT WILL NOT TURN OFF THE STEAM AFTER THE ALARM SOUNDS.
5. To STOP the flow of steam, press the TIMED end of the MANUAL/TIMED rocker switch. Steam stops flowing into the cooking compartment.

Automatic Cooking Operation - Key Pad Controls

Each Convection Pro XVI steamer cooking compartment is equipped with an independent electronic digital timer, which has a maximum setting of 99 minutes and 99 seconds. Each timer is connected to a temperature sensing device in the cooking compartment. THE SENSOR CIRCUIT ALLOWS THE TIMER TO COUNT DOWN ONLY WHEN THE COOKING COMPARTMENT IS AT THE PROPER COOKING TEMPERATURE. This assures uniformity in the cooking times as the timer automatically compensates for food product defrosting and/or heat-up time.

1. Place the pan(s) of food into the cooking compartment.
2. Clear and reset the timer. The timer can be set only when the COOKING TIME display is clear. Press the CLEAR key on the number pad to zero the timer.
3. Set the desired cooking time. The cooking time display contains four digits. The left two digits are minutes, and the right two digits are seconds. The display 12:34 is set for 12 minutes and 34 seconds.
 - a. To set the cooking time, change the required cooking time to minutes and seconds, press the number keys for the minutes, and then press the number keys for the seconds. If the cooking time is 99 seconds or less, only press the number keys for seconds.
 - b. Example 1. To set the timer for 1 hour and 15 minutes: Change 1 hour (60 min) and 15 minutes to 75 minutes. Press the following number keys in sequence: 7 5 0 0. The display will read 75:00 when properly set for 1 hour and 15 minutes.
 - c. Example 2. To clear the time numbers set in example 1, press the CLEAR key on the number pad. The display returns to 00:00.
 - d. Example 3. To set the timer for 1.5 minutes: Change the time to 1 minute and 30 second. Press the following number keys in sequence: 1 3 0. The display will read 01:30, when set for 1.5 minutes.
All seconds method: Change the 1.5 minutes to 90 seconds and press 9 0. The display will read 00:90, when set for 1.5 minutes.
4. Press the START/STOP key to start the timer. When the START/STOP key is pressed, steam enters the cooking compartment.

Installation, Use and Care Instructions

Convection Pro XVI

- a. THE TIMER WILL BEGIN TO COUNT DOWN ONLY AFTER THE COOKING COMPARTMENT REACHES PROPER COOKING TEMPERATURE. The timer automatically delays to compensate for defrosting and/or food product heat-up time.
- b. For example, a timer setting of 10 minutes may in fact take 11 or 12 minutes for the timer to count down and the alarm to sound. This is normal. Heating the compartment and food to cooking temperature uses the additional time.
- c. To stop or reset the timer, press and hold the START/STOP key. The cooking time display returns to the last time setting.
 - To restart the same time, press the START/STOP key.
 - To set a new time press the CLEAR key, and set the new time.
5. When the timer counts down to zero, an alarm sounds continuously. Press the START/STOP key to silence the alarm. The cooking time display returns to the last time setting. Either run this same setting again or clear and reset the timer.
6. Example 4. To cook two 14 minutes cycles: Press the CLEAR key to clear the timer. Press the following number keys in sequence: 1 4 0 0. The display shows 14:00. Press the START/STOP key to start the timer. When the display counts down to zero, the alarm sounds. Press the START/STOP key, and the display returns to 14:00. Press the START/STOP key to start the second 14 minute cycle.

Cooking Operations for The Dial Timer Control Panel

The dial timer control panel is illustrated in Figure 3.

The Cleveland Convection Pro XVI steamer has two cooking modes: Manual and Automatic. The Manual Mode provides continuous steaming and is turned on and off by the MANUAL/TIMED rocker switch. The Automatic Mode monitors cooking time to provide accurate, efficient, steam cooking.

NOTE: Whether using timed or manual cooking modes, optimum steam heat transfer, and therefore a higher quality food product, is achieved when shallow, perforated, uncovered pans are used.

WARNING

LIVE STEAM may cause severe burns. Use extreme caution when opening the steamer door. Turn face away from the steamer when first opening the door. Do not look into the cooking compartment until steam has cleared. **KEEP HANDS OUT OF THE COOKING COMPARTMENT TO PREVENT BURNS.**

Manual Cooking Operation - Dial Timer Controls

Use manual mode for a continuous supply of steam for long periods, or if the required cooking time is unknown and frequent inspection is required.

1. Place the pan(s) of food into the cooking compartment.
2. To START the flow of steam, press the MANUAL end of the MANUAL/TIMED rocker switch, located below the timer. Steam immediately starts flowing into the cooking compartment.
3. If food inspection is required during steaming, refer to the LIVE STEAM WARNING above. Use extreme caution when opening the steamer door during steaming operations.
4. Although the timer cannot turn the steam off in manual mode, it can be used as a conventional cooking timer. Refer to the timer setting instructions under Automatic Operation and set the timer. The timer will count down the set period and sound the buzzer, but IT WILL NOT TURN OFF THE STEAM AFTER THE ALARM SOUNDS.
5. To STOP the flow of steam, press the TIMED end of the MANUAL/TIMED rocker switch. Steam stops flowing into the cooking compartment.

Automatic Cooking Operation Dial Timer Controls

Each Convection Pro XVI steamer cooking compartment is equipped with an independent dial timer. This timer controls the cooking compartment steaming cycle. Use automatic mode when an exact cooking time is required. Steam cooking begins when the timer is set, and automatically stops when the timer counts down to zero.

1. Check that the MANUAL/TIMED rocker switch is in the TIMED position. If it is not, press the TIMED end of the MANUAL/TIMED rocker switch.
2. Place the pan(s) of food into the cooking compartment.
3. Set the desired cooking time. Turn the dial until it points to the desired cooking time. When the dial timer is set, steam enters the cooking compartment.
4. When the timer counts down to zero, an alarm sounds for three seconds, and steam flow into the cooking compartment stops.

Boiler Shutdown

The red-lighted power switch must be shut off for 3 minutes a minimum of once every 8 hours to automatically drain highly mineralized water from the boiler, which reduces the formation of scale. See step 1 in CARE AND CLEANING instructions, which follow.

Installation, Use and Care Instructions

Convection Pro XVI

CARE AND CLEANING

The Cleveland Convection Pro XVI steamer must be cleaned regularly to maintain its fast, efficient cooking performance, and to ensure its continued safe, reliable operation.

1. The boiler must be drained (blowdown) after a maximum of 8 hours of use. If the boiler feedwater contains more than 60 parts per million of total dissolved solids, the boiler must have a blowdown more often, the frequency depending upon the mineral content of the feedwater. Blowdown means the boiler must be drained under pressure.

THE BOILER BLOWDOWN IS PERFORMED BY SIMPLY SHUTTING OFF THE STEAMER'S RED-LIGHTED POWER SWITCH WHILE THE BOILER IS AT NORMAL 10 PSI OPERATING PRESSURE. WHEN THE BOTTOM OF THE POWER ROCKER SWITCH IS PRESSED, ITS RED LIGHT GOES OUT, AND THE DRAIN VALVE AUTOMATICALLY OPENS, DRAINING THE BOILER. AN AUTOMATICALLY-TIMED DRAIN WATER CONDENSER WILL FLUSH THE DRAIN FOR 3 MINUTES, THEN SHUT OFF. AFTER 3 MINUTES THE STEAMER IS READY TO BE RESTARTED.

When steam is produced, the water in the boiler is being distilled. During this process, the minerals that come into the boiler with the water, remain in the boiler as the water boils away as steam. When allowed to accumulate, the water becomes highly mineralized, which results in erratic operation, lime build-up, corrosion, and premature electric heater failures. In some cases, complete boiler replacement becomes necessary, which is extremely expensive. By draining the boiler under pressure, most sediment present will be flushed down the drain.

2. The steamer is equipped with a drain in the back of the cooking compartment. No compartment should be operated without the drain screen in place. This screen prevents large food particles from entering and possibly plugging the drain line. Any restriction of the drain line may cause a slight build-up of back pressure in the compartment, resulting in steam leaks around the door gasket. It also may adversely affect the convection action of the steam in the compartment, which is critical to optimum performance. Pouring USDA approved drain cleaner through the compartment drains once a week will help to ensure an open drain. A manual (hand crank) drain auger, or "snake", may be safely used to clear obstructions in the compartment drains. Do not use a power auger, as damage to the plastic drain system will result.

With the steamer off, open the cooking compartment doors and allow the steamer to cool before cleaning the cooking compartments and their components.

3. At the end of each day's operation, wash the pan slides, steam tubes, door gaskets, and compartment interiors with mild detergent and warm water, either by hand or in a dishwasher. Rinse thoroughly with clear water. Rinse water should drain freely through the compartment drain

openings. If it does not, the drain must be cleaned before using the steamer.

4. Once a week, remove the steam tubes and clean the orifices. First, remove the pan slides by lifting upward and toward the center of the compartment. Pressing backward on the steam tube will allow its front eyelet to clear the compartment stud. The tube is then angled toward the center of the compartment just enough to clear the stud and be pulled forward, out of its socket. The orifices can be cleaned easily with a paper clip. Then, thoroughly wash and rinse all steam tubes. This can be done in a dishwasher. Lubricate each tube's tapered end with cooking oil before replacing in the steamers compartments. Be sure all four steam tubes are securely in place before activating the compartment. The tubes are interchangeable and may be placed in any spot in either compartment.
5. To prolong door gasket life, always leave compartment door ajar when not in use.
6. Exterior Care: Allow steamer to cool before washing. Use the same cleaners and cleaning procedures as for other kitchen surfaces of stainless steel and aluminum. Mild soapy water, with a clear water rinse, is recommended. Do not allow water to run into electrical controls. Always turn off equipment power before using water to wash equipment. Do not hose down the steamer.

WARNING

Do not store or use gasoline or other flammable vapors and liquids in the vicinity of this or any other appliance.

MAINTENANCE

Periodically, a qualified serviceman should be summoned for routine preventive maintenance.

1. The blowdown procedure will not completely remove the mineral deposits that adhere to the top of the boiler. A chemical descaling should be done by a boiler treatment specialist. This should be done once a year in average water conditions, but in poor water areas it may be needed two or three times a year.
2. Periodic boiler inspection should be made by a qualified serviceman.
3. Once every three months, the cold water line strainer should be cleaned.

Cleveland Range supports a comprehensive network of Maintenance and Repair Centers (regional parts and service distributors) throughout the United States and Canada. Please contact your nearest distributor for the name of an authorized service agency in your area, or for replacement parts and information regarding the proper maintenance and repair of Cleveland Range equipment. In order to maintain the various agency safety certifications, only factory-supplied replacement parts should be used. The use of other than factory-supplied replacement parts will void the warranty.

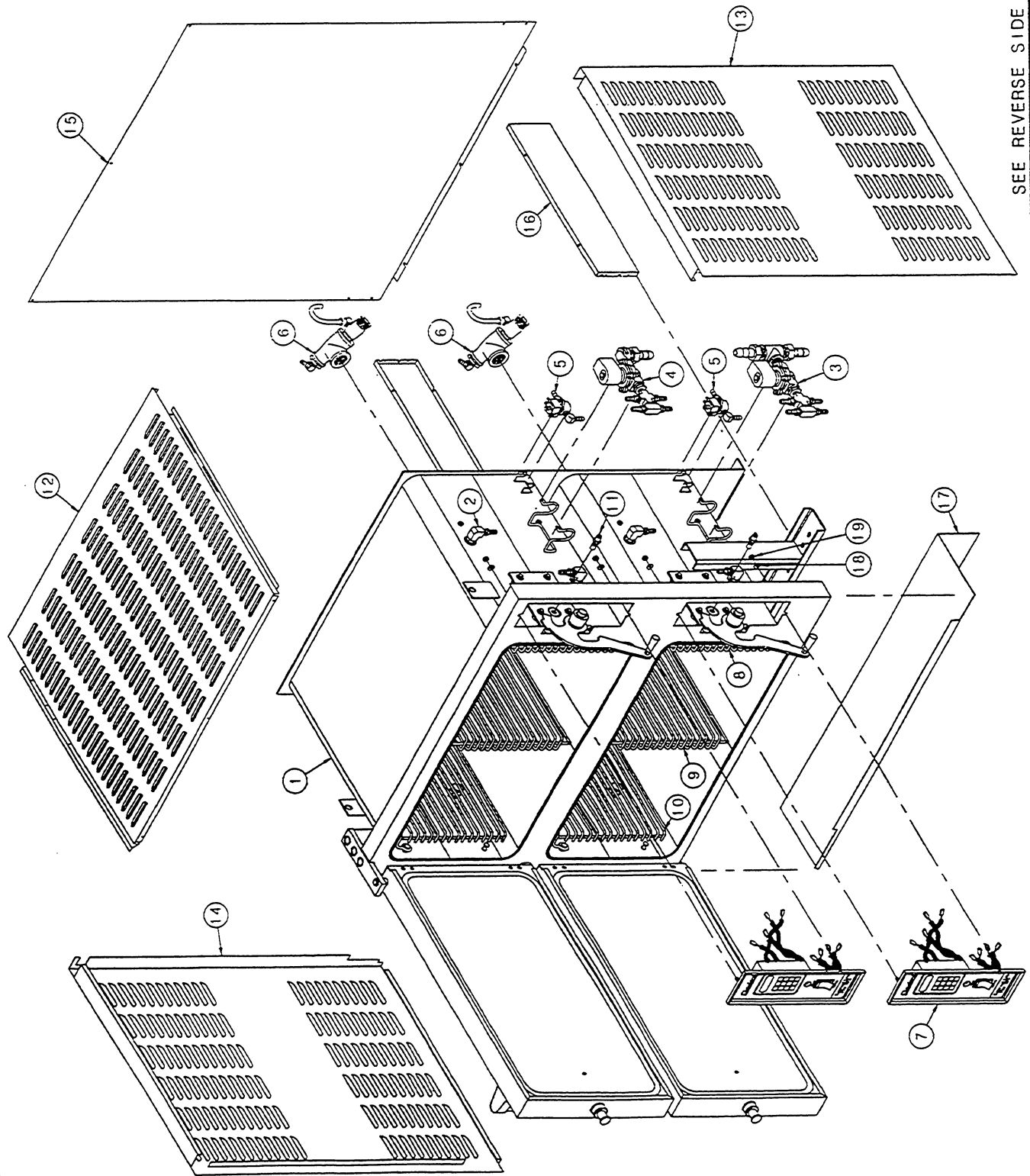

SEE REVERSE SIDE FOR PARTS LIST

Cleveland Convection Pro

Sheet 1

Parts List Below Is For Drawing On Previous Page

Item	Part Number	Description
1	See Sheet 2	Upper Assembly, Intermediate, Convection Pro
2	106203	Spray Nozzle Assembly
3	See Sheet 7	Steam Inlet Assembly, Lower Compartment
4	See Sheet 7	Steam Inlet Assembly, Upper Compartment
5	104381	Fitting, Hose, 1/4 MPT x 1/4 H, Straight
	22241	Valve, Solenoid, 1/4
	105786	Fitting, Hose, 1/4 MPT x 1/4 H, 90°
6	See Sheet 8	Drain Assembly, Compartment, Back
7	See Sheet 5	Panel Assembly, Electronic
	See Sheet 6	Panel Assembly, Mechanical
8	102420	Rack, Assembly, Right Side, PCL
9	102003	Rack, Assembly, Center Wire, PCL
10	102421	Rack, Assembly, Left Side, PCL
11	19972	Thermal Switch
12	100697	Panel, Top, Weldment, PCL
13	100132	Panel, Right Side, Sheeting, PCL
14	100131	Panel, Left Side, Sheeting, PCL
15	66721	Panel, Rear Cover, PCL
16	101737	Panel, Pedestal, Side, Weldment
17	1044741	Pedestal Weldment
18	23116	Washer, Flat, 1/4 x 5/8 x .065
19	14665	Nut, Hex, Elastic Lock, 1/4-20



Cleveland Range, Inc.
1333 East 179th St.
Cleveland, OH 44110
Ph: (216) 481-4900 Fax: (216) 481-3782

92/03/28

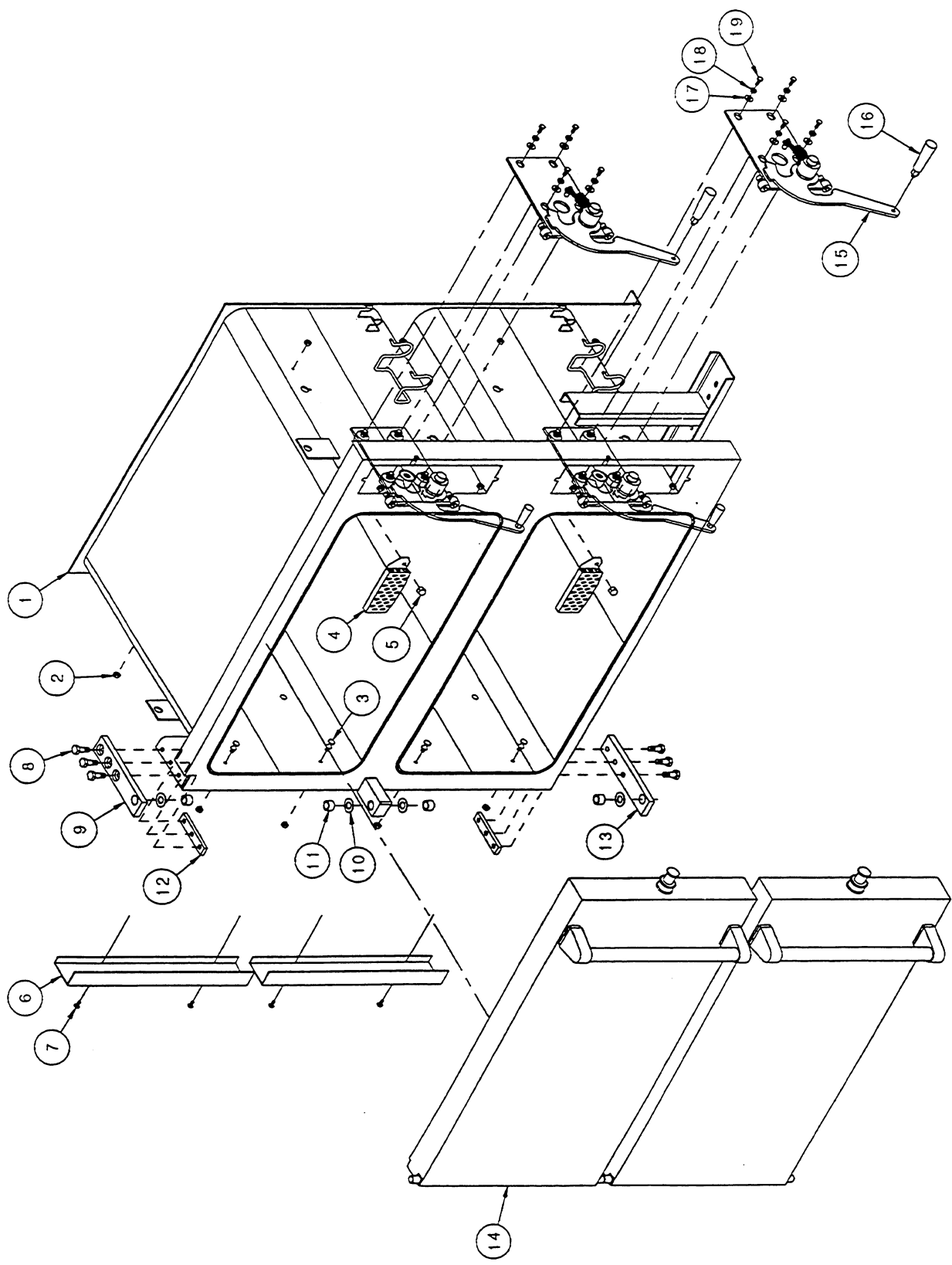

SEE REVERSE SIDE FOR PARTS LIST

CONVECTION PRO 02

Cleveland Convection Pro

Parts List Below is For Drawing On Previous Page

Item	Part Number	Description
1	105836	Cavity, Weld Assembly, Convection Pro
2	14618	Nut, Hex, 1/4-20, S/S
3	101305	Pin, Rack
4	69298	Screen, Compartment Drain
5	146771	Nut, Acorn, 1/4-20
6	53124	Channel, Door End
7	101231	Screw, Truss Head, 10-24 x 1/2, S/S
8	191241	Screw, Hex Head, 3/8-16 x 1.00
9	101936	Bar, Hinge Top
10	100539	Washer, Door Hinge
11	02093	Bearing, .568 ID x .753 OD
12	100004	Bar, Nut, Three 3/8-16 Holes
13	101935	Bar, Hinge Bottom
14	See Sheet 3	Door Assembly, Convection Pro
15	See Sheet 4	Door Assembly, Convection Pro
16	106236	Handle Assembly, PCL/PCS Steamer
17	23120	Washer, Flat, 3/8 x 7/8 x 1/16
18	23108	Washer, Lock, Medium Pattern, 5/16, S/S
19	13129	Screw, Hex, 3/8-16 x 7/8, Alloy Steel

Cleveland Range, Inc.
 1333 East 179th St.
 Cleveland, OH 44110
 Ph: (216) 481-4900 Fax: (216) 481-3782



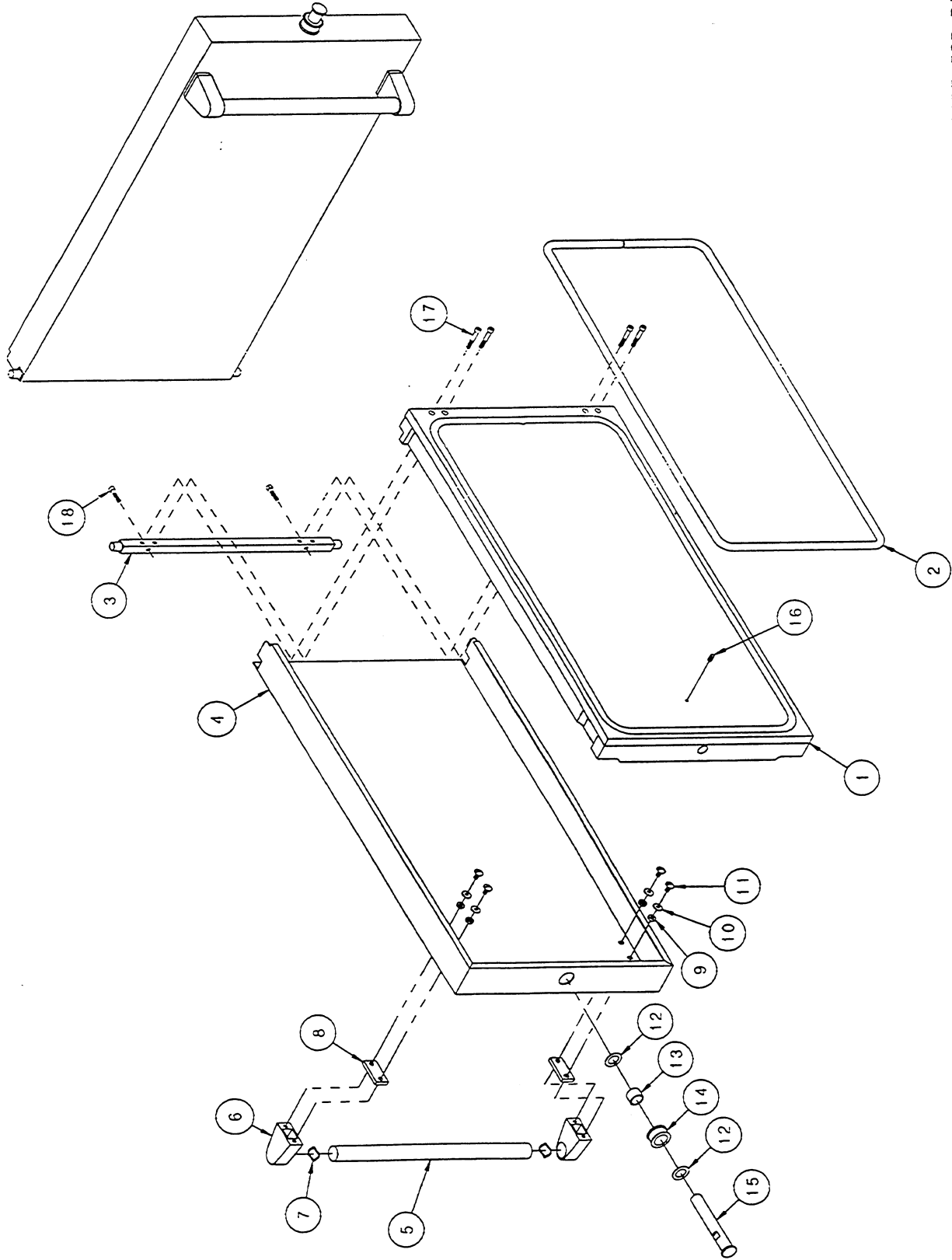

SEE REVERSE SIDE FOR PARTS LIST

CONVECTION PRO 03

Cleveland Convection Pro

Parts List Below Is For Drawing On Previous Page

Item	Part Number	Description
1	105825	Door, Weldment, Convection Pro
2	104292	Gasket, Door, Convection Pro
3	52061	Bar, Hinge, Pivot
4	54230	Cover, Door, Convection Pro
5	100759	Bar, Door, Handle
6	1010441	Bracket, Door Handle
7	100990	Spring, Wave
8	101048	Pad, Insulator, Plastic
9	23105	Washer, Lock, 1/4, Katlink, S/S
10	23116	Washer, Flat, 1/4 x 5/8 x .065, S/S
11	19176	Screw, Truss Head, Slotted, 1/4-20 x 1/2
12	23098	Washer, Flat, 3/4 x 1.187 x .05, S/S
13	02096	Bearing, .753 ID, Porous Bronze
14	68084	Roller, Door Latch
15	52531	Pin, Roller
16	19136	Screw, Set, Cup Point, 1/4-20 x 1/2, S/S
17	19123	Screw, Socket Head, 1/4-28 x 1 1/2, S/S
18	100557	Screw, Socket Head, 1/4-28 x 1". S/S



Cleveland Range, Inc.
 1333 East 179th St.
 Cleveland, OH 44110
 Ph: (216) 481-4900 Fax: (216) 481-3782

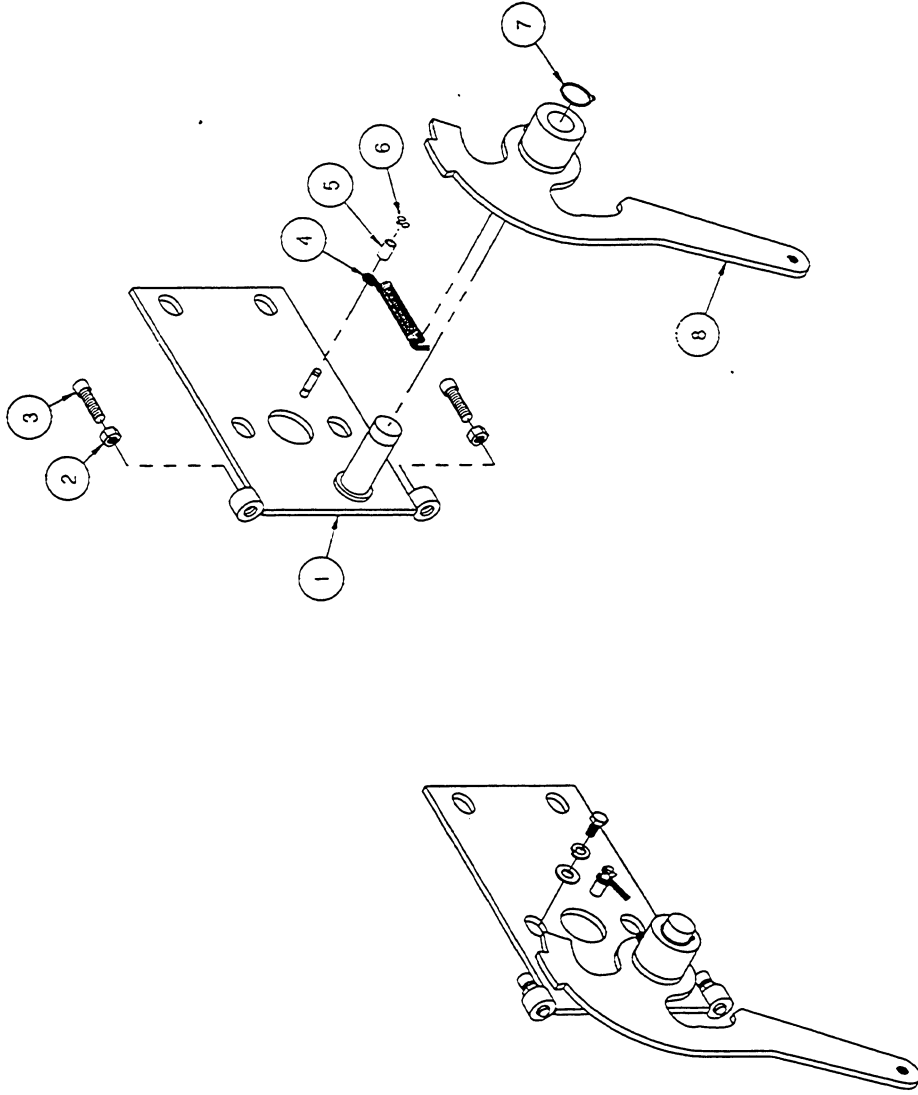

SEE REVERSE SIDE FOR PARTS LIST

CONVECTION PRO 04

Parts List Below Is For Drawing On Previous Page

Item	Part Number	Description
1	105917	Plate, Latch Mount, Weldment
2	14675	Nut, 3/8-16, S/S
3	100605	Screw, Socket Head, Cap, 3/8-16 x 1 1/4
4	100710	Spring, Latch
5	101408	Tubing, Latch Bumper
6	18307	Pin, Retainer
7	1044871	Handle Assembly
8	18306	Ring, Retaining

Cleveland Range, Inc.
1333 East 179th St.
Cleveland, OH 44110
Ph: (216) 481-4900 Fax: (216) 481-3782



CLEAN PANEL BEFORE
APPLYING OVERLAY

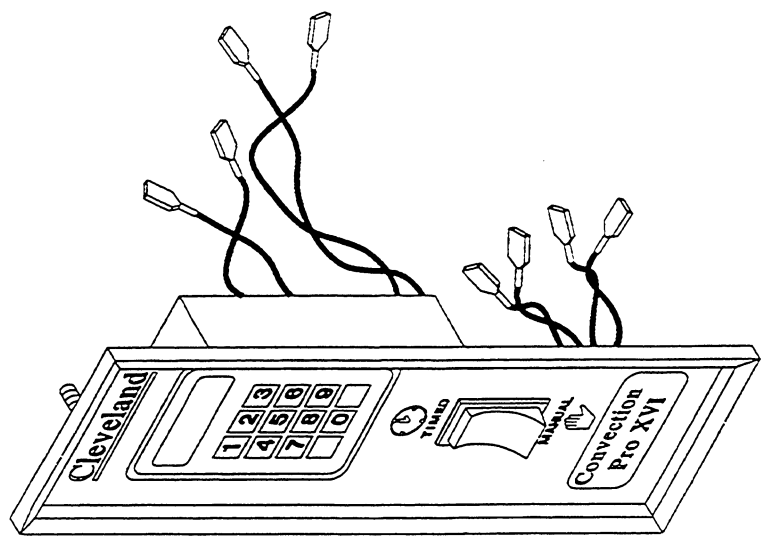
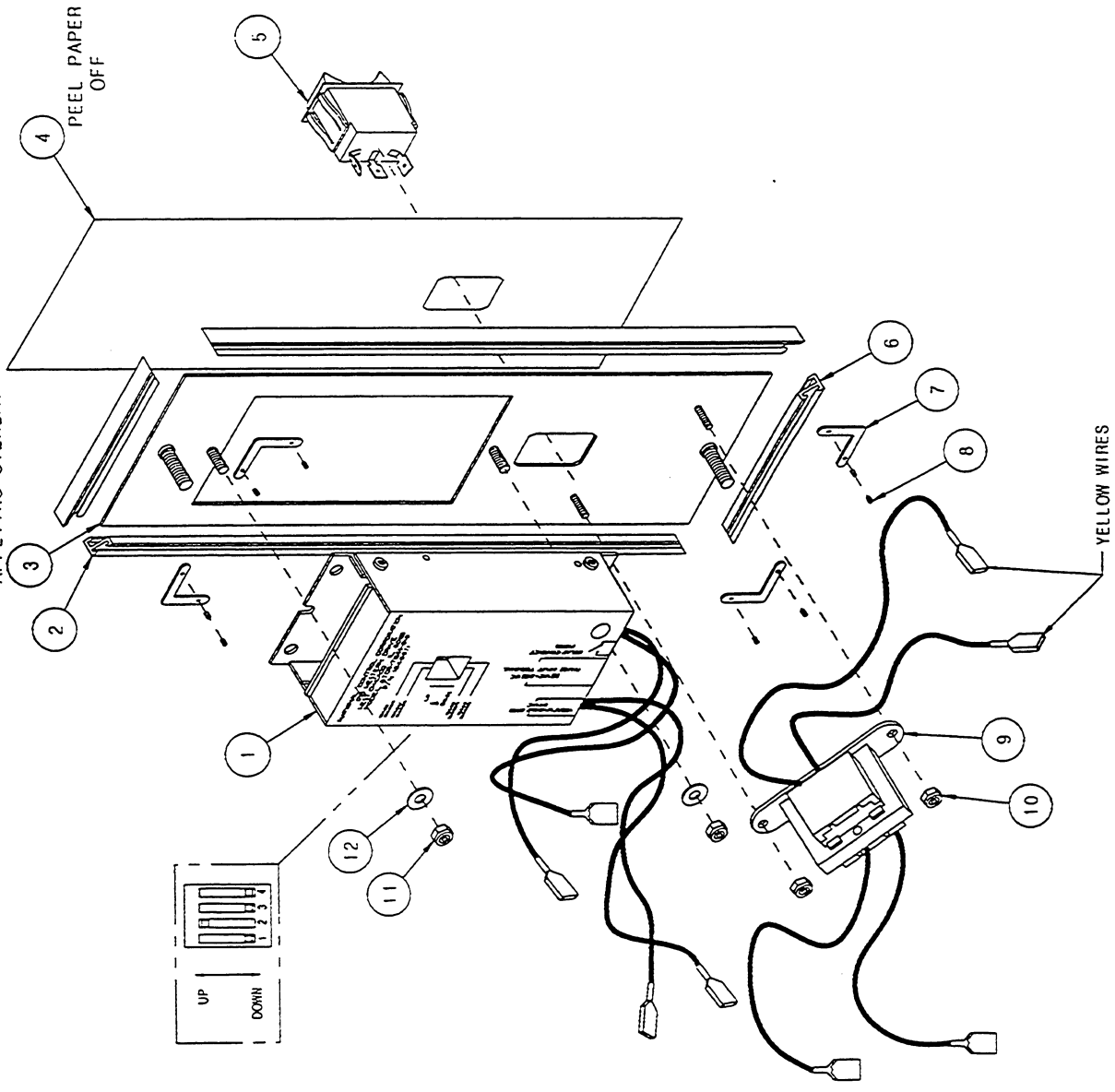

SEE REVERSE SIDE FOR PARTS LIST

Cleveland Convection Pro

Sheet 5

Parts List Below Is For Drawing On Previous Page

Item	Part Number	Description
1	104389	Timer, Assembly - NCC
2	56237	Bar, Instrument Panel Frame, Side
3	103981	Panel, Weldment, Convection Pro, Electronic
4	106599	Label, Control Panel, Convection Pro
5	104224	Switch, Rocker, SPDT, Matte Finish
6	56235	Bar, Instrument Panel Frame, Top/Bottom
7	53264	Clip, Instrument Panel Frame, PCL
8	19151	Screw, Set, Cup Point, 3-48 x .125, S/S
9	104390	Transformer Assembly
10	104223	Nut, Hex, 6-32, Elastic Lock
11	14692	Nut, Hex, 10-24, Elastic Lock
12	101655	Washer, Flat, #10, S/S



Cleveland Range, Inc.
1333 East 179th St.
Cleveland, OH 44110
Ph: (216) 481-4900 Fax: (216) 481-3782

92/03/28

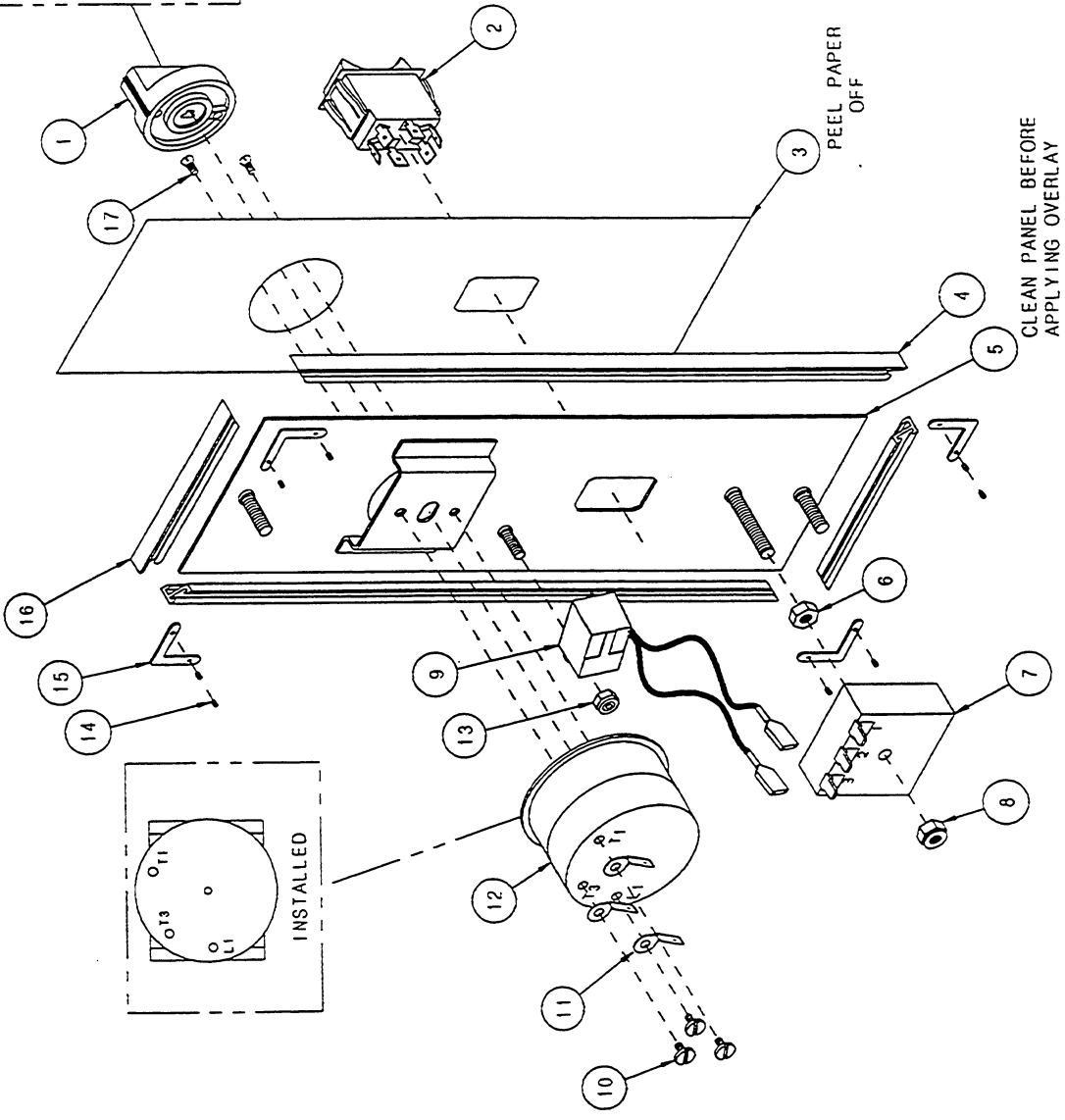
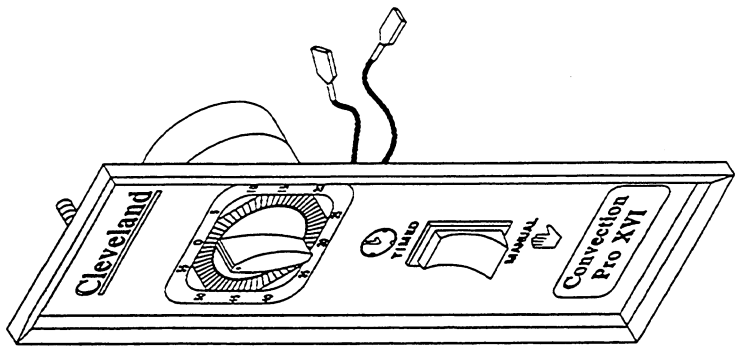
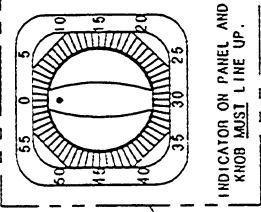

SEE REVERSE SIDE FOR PARTS LIST

Cleveland Convection Pro

Sheet 6

Parts List Below Is For Drawing On Previous Page

Item	Part Number	Description
1	11307	Knob, Timer
2	19992	Switch, Rocker, Compartment Bypass
3	105822	Label, Control Panel, Convection Pro
4	56237	Bar, Instrument Panel Frame, Side
5	103974	Panel, Weldment, Convection Pro, Mechanical
6	14618	Nut, Hex, 1/4-20, S/S
7	20477	Timer, Solid State, 3 Second Delay
8	101873	Nut, 1/4-20, Elastic Lock
9	41350	Buzzer Assembly with Terminals Included With Item 10
10		
11	20323	Terminal, #10 Ring, .25 Male Tab
12	20476	Timer, 60 Minute, Mechanical Switching
13	14692	Nut, 10-24, Elastic Lock, Steel Plated
14	19151	Screw, Set, Cup Point, 3-48 x .125, S/S
15	53264	Clip, Instrument Panel Frame, PCL
16	56235	Bar, Instrument Panel Frame, Top/Bottom
17	19201	Screw, Pan Head, Slotted, 5-40 x .250, S/S



Cleveland Range, Inc.
1333 East 179th St.
Cleveland, OH 44110
Ph: (216) 481-4900 Fax: (216) 481-3782

92/03/28

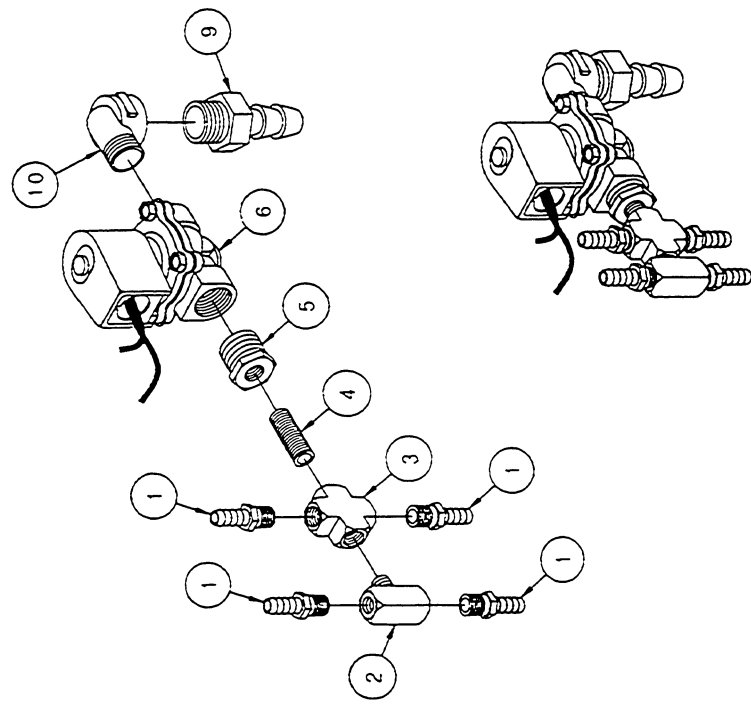
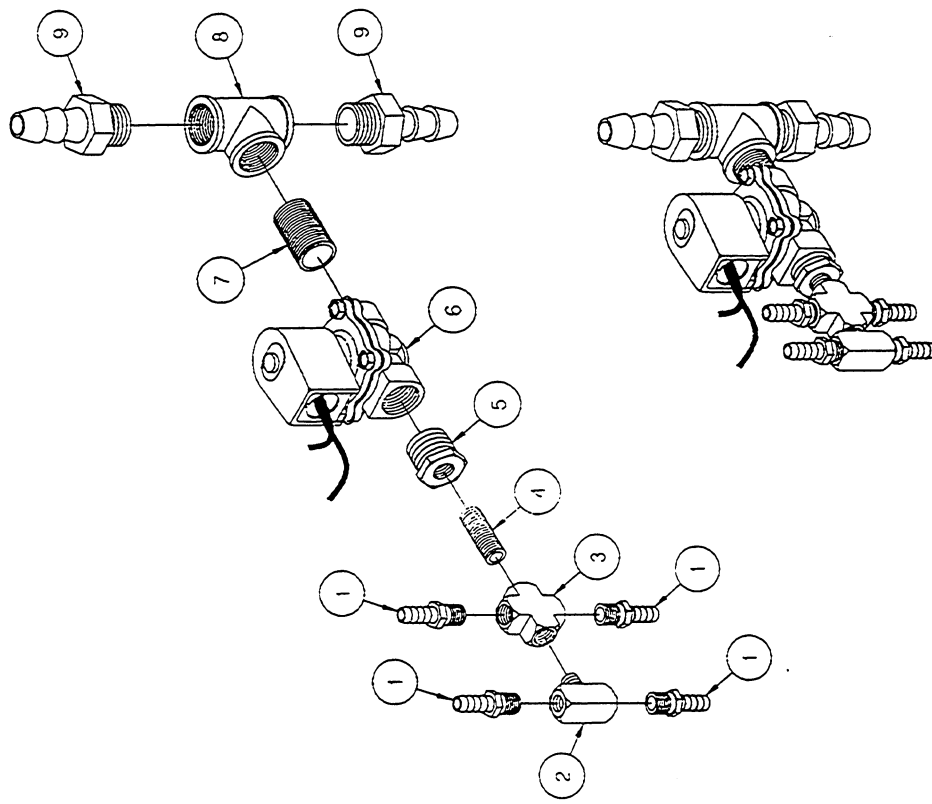

SEE REVERSE SIDE FOR PARTS LIST

CONVECTION PRO 07

Cleveland Convection Pro

Parts List Below Is For Drawing On Previous Page

Item	Part Number	Description
1	105277	Fitting, Hose Barb, 3/8 H x 1/4 NPT
2	20245	Tee, Male Branch, 1/4, Brass
3	03729	Cross, 4-Way, 1/4, Brass
4	14304	Nipple, 1/4 x Close, Brass
5	02563	Bushing, Hex, 3/4 x 1/4, Brass
6	22193	Valve, Solenoid, 3/4 x 3/4, 120V, 60Hz
7	14342	Nipple, 3/4 x Close, Brass
8	20206	Tee, 3/4 x 3/4 x 3/4, Brass
9	06240	Fitting, Hose Barb, 3/4 H x 3/4 MPT
10	05231	Elbow, Street, 3/4 x 90°, Brass



Cleveland Range, Inc.
 1333 East 179th St.
 Cleveland, OH 44110
 Ph: (216) 481-4900 Fax: (216) 481-3782

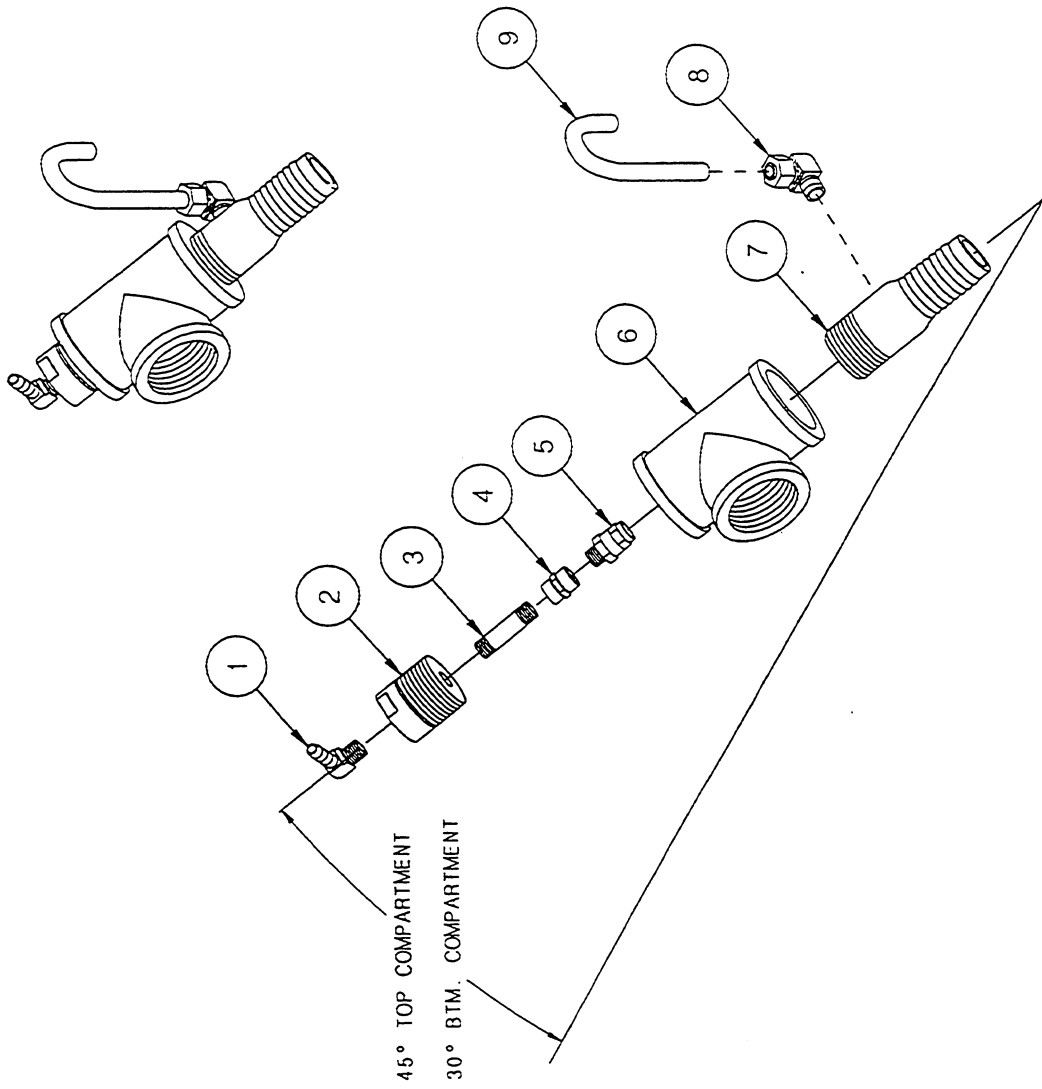

SEE REVERSE SIDE FOR PARTS LIST

CONVECTION PRO 08

Parts List Below Is For Drawing On Previous Page

Item	Part Number	Description
1	105786	Fitting, Hose, 1/4 H x 1/4 MPT x 90°
2	06230	Fitting, Compartment Drain
3	14297	Nipple, 1/8 x 1½, S/S
4	14555	Nozzle, Spray, 1/8, Full Jet
5	104838	Coupling, Full, 1/8, Brass
6	105783	Tee, 1" x 1" x 1¼, Black
7	565191	Fitting, Hose, 1" with 1/8 Hole
8	06233	Fitting, Comp, 3/8 T x 1/8 MPT, 90°
9	70732	Tube, Air Vent, 3/8, Copper



Cleveland Range, Inc.
1333 East 179th St.
Cleveland, OH 44110
Ph: (216) 481-4900 Fax: (216) 481-3782

250 BTU (5 BURNERS) AND 300 BTU (6 BURNERS)

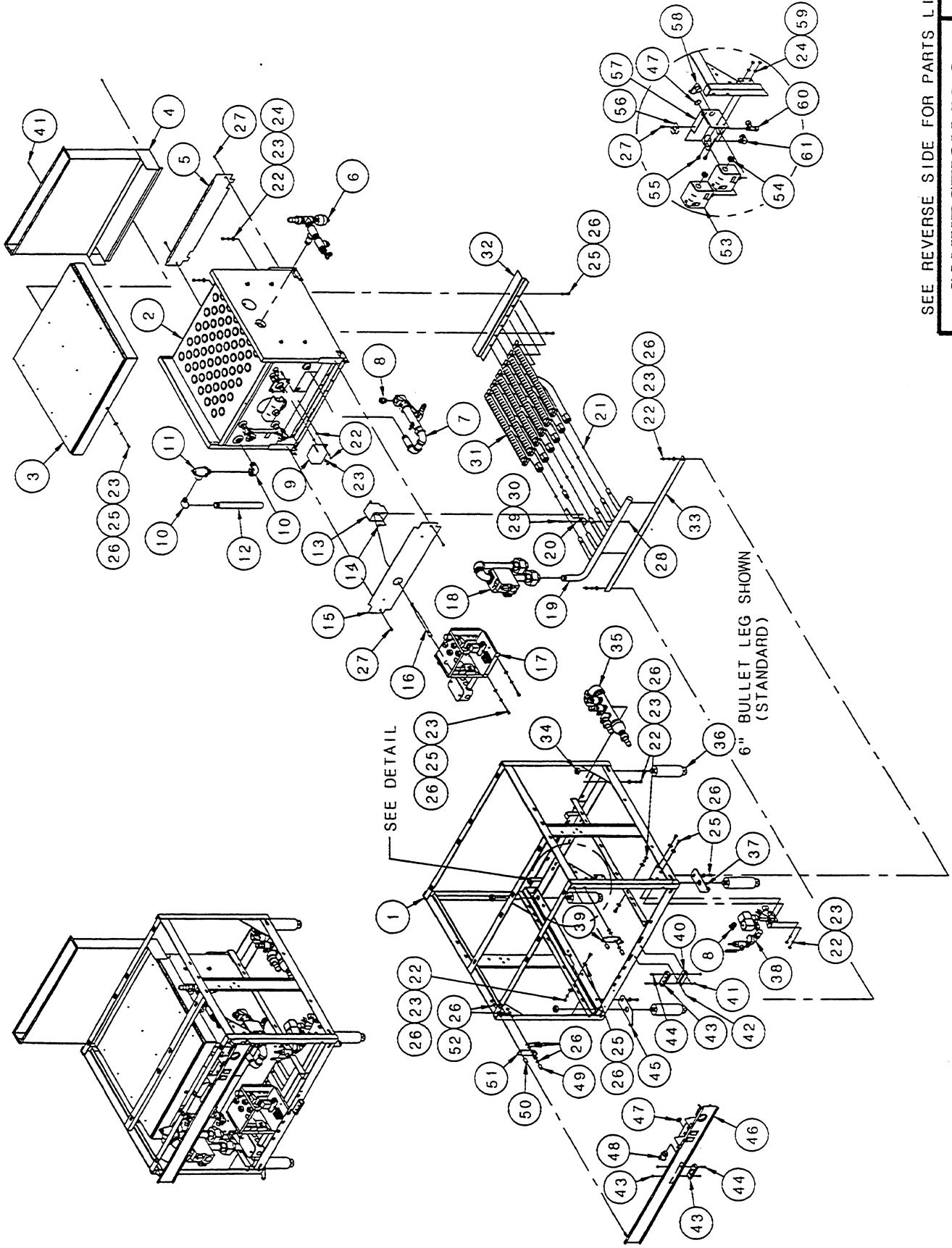

SEE REVERSE SIDE FOR PARTS LIST

Cleveland Convection Pro

Parts List Below Is For Drawing On Previous Page

Item	Part Number	Description
1	41120	Base, Weldment, 900mm, S/S
	411201	Base, Weldment, 900mm, A.C.S.
2	See Sheet 10	Gas Generator Assembly, with Reference Parts
3	1009811	Collector Assembly, Top Flue, Large Gas
4	1011301	Flue Riser Assembly, Internal
5	52192	Baffle, Rear, 250/300 KBTU
6	See Sheet 11	Steam Outlet Assembly
7	See Sheet 12	Blowdown Assembly, PCL, Gas
8	105243	Connector, Greenfield, 3/8, Straight
9	52305	Box, Probe Cover, 2 Probes, A.C.S.
10	05259	Elbow, Street, 3/4, 90°, Black
11	22131	Valve, Safety, 3/4, 15 PSI, Bronze
12	14487	Nipple, T.O.E., 3/4 x 9, Black
13	44096	Box, Igniter Assembly
14	19287	Screw, Pan Head, 10-24 x .5, S/S
15	40842	Baffle, Front, 300 KBTU R/B
16	44169	Cable, Ignition Assembly
17	See Sheet 13	Box, Electric, Assembly for 2 Probe Gas
18	See Sheet 14	Valve Assembly, Natural Gas, 250/300 KBTU
	See Sheet 14	Valve Assembly, Liquid Propane, Large Gas
19	40922	Manifold Assembly, Reverse Bend, 300 KBTU
20	52602	Bracket, Alignment Manifold
21	15453	Orifice, Natural Gas, #29 Drill
	15450	Orifice, Liquid Propane, #45 Drill
22	14618	Nut, Hex, 1/4-20, S/S
23	23105	Washer, Lock, 1/4, Katlink Style
24	23137	Washer, Lock, 1/4, Internal Tooth, S/S



Cleveland Range, Inc.
 1333 East 179th St.
 Cleveland, OH 44110
 Ph: (216) 481-4900 Fax: (216) 481-3782

25	19288	Screw, Hex Head, 1/4-20 x 3/4, S/S
26	23116	Washer, Flat, 1/4 x 5/8 x .065
27	19148	Screw, Hex Washer Head, 10 x .5
28	19294	Screw, Round Head, 10-24 x .75 Long
29	23113	Washer, Split Lock, 10, Zinc Plated
30	14659	Nut, Hex, 10-24, S/SPS
31	02497	Burner Assembly, Gas
32	44157	Bracket, Support, Rear, 300, KBTU
33	63184	Bracket, Manifold, 900mm Base, S/S
	1009351	Bracket, Manifold, 900mm Base, Aluminized Steel
34	14668	Nut, Hex, Jam, 3/4-10, Zinc Plated
35	See Sheet 15	Drain Assembly
36	06156	Leg, Bullet, 6"
37	1020663	Hinge, Lower Right
38	See Sheet 16	Water Feed Assembly, Reverse Bend Generator
39	412192	Bracket Assembly, Top Hinge, R.S.
40	53274	Clip, Magnetic Catch, S/S
41	14674	Nut, Hex, 6-32, Zinc Plated
42	18358	Rivet, 1/8 Diameter, Flush Break, S/S
43	03100	Catch, Magnetic
44	19206	Screw, Round Head, 6-32 x 1", Zinc Plated
45	1020662	Hinge, Lower Left
46	See Sheet 17	Console Assembly, 900mm, 2 Switch
47	19329	Plug, Snap-In, 1/2" for 7/8" Hole
48	105246	Connector, Greenfield, 1/2, Straight
49	195552	Spacer
50	19555	Spacer
51	412182	Bracket Assembly, Top Hinge, S/S



Cleveland Range, Inc.
1333 East 179th St.
Cleveland, OH 44110

Ph: (216) 481-4900 Fax: (216) 481-3782

Cleveland Convection Pro

52	14665	Nut, Hex, Lock, 1/4-20, S/S
53	19947	Switch Pressure Control
54	02599	Bushing, Insulating, 3/8 x 1/2, Heyco
55	19218	Screw, Hex Head, 1/4-20 x .375, S/S
56	52499	Bracket, Pressure Switch Retainer
57	526241	Bracket, Pressure Switch, Gas/Electric
58	105247	Connector, 1/2 x 90°, Snapfit
59	14688	Nut, Hex, Jam, 1/4-20, S/S
60	100883	Fitting, Comp Tee, 3/8 x 1/4 NPT x 3/8
61	06196	Fitting, Comp, 3/8 x 1/4 MPT, 90°

Also Required For Liquid Propane

52615	Baffle, Side
52614	Baffle, Front Burner, Gas, Liquid Propane Only



Cleveland Range, Inc.
 1333 East 179th St.
 Cleveland, OH 44110
 Ph: (216) 481-4900 Fax: (216) 481-3782

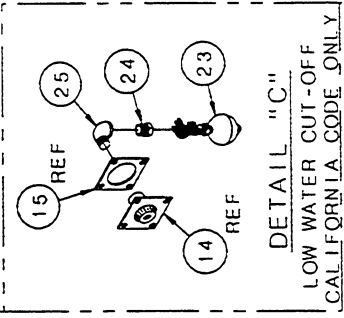
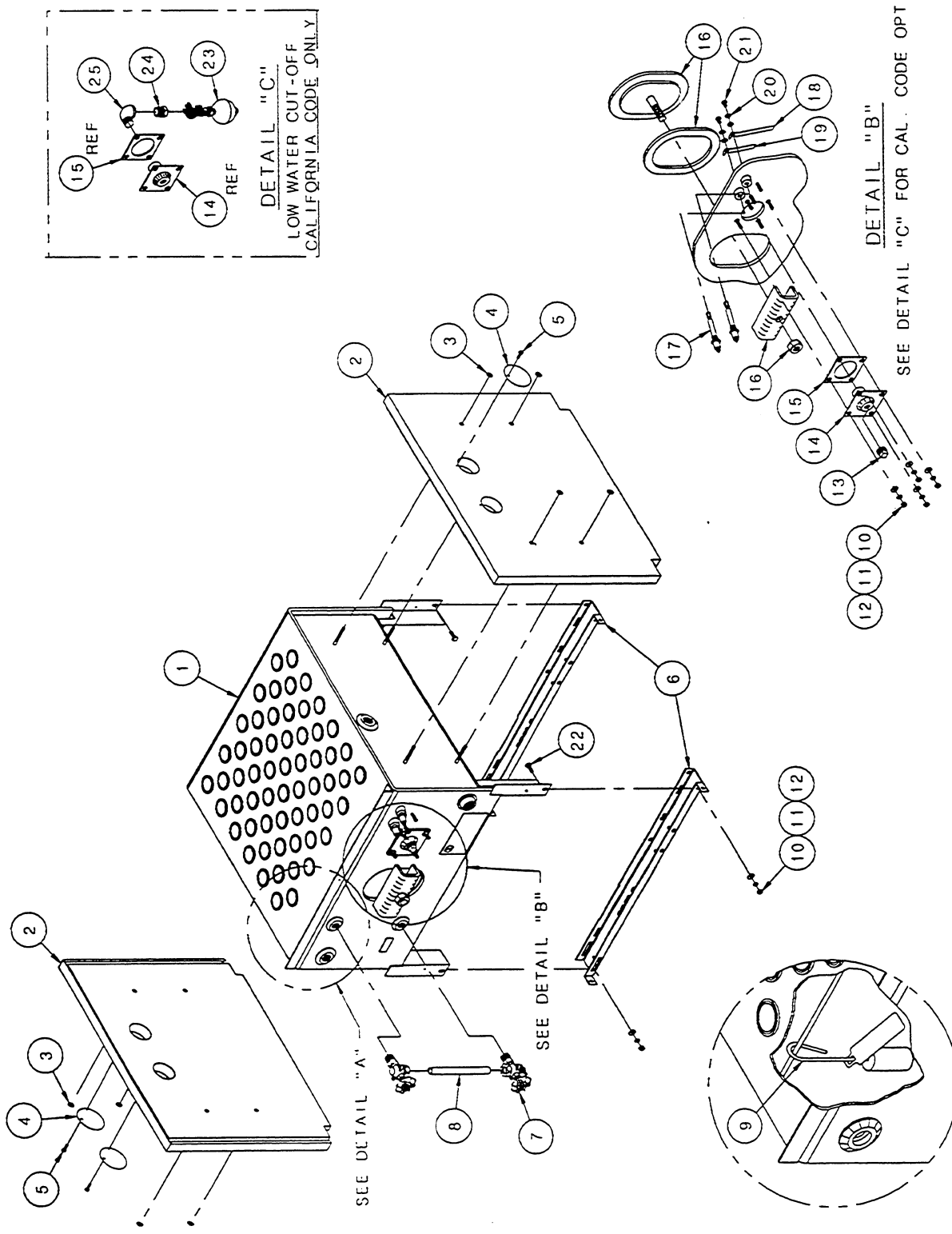

DETAIL "B"

SEE DETAIL "C" FOR CAL. CODE OPTION

DETAIL "A"

SEE REVERSE SIDE FOR PARTS LIST

Parts List Below Is For Drawing On Previous Page

Item	Part Number	Description
1	407431	Generator Assembly, Gas - Weldment
2	100980	Panel, Insulation Assembly, Rt/Lt, Natural Gas
	1009802	Panel, Insulation Assembly, Rt/Lt, Liquid Propane
3	14263	Fastener, Pushnut, 1/4 Stud Diameter
4	105539	Disk, Hole Cover, Side Insulation Panel
5	19148	Screw, Hex Washer Head, 10 x 1/2
6	69967	Support, Generator Mounting Channel, 900/1050mm
7	07176	Gauge, Fittings, Water, 1/2
8	07302	Gauge, Water, 5/8 x 6, Glass
9	43895	Anode Assembly, Corrosion Prevention
10	14618	Nut, Hex, 1/4-20, S/S
11	23105	Washer, Split Lock, 1/4, S/S
12	23116	Washer, Flat, 1/4, S/S
13	16602	Plug, Square, 1/2 Pipe, Black
14	41943	Plate, Mounting
15	07128	Gasket, Heater
16	40421	Hand Hole Plate and Bar Assembly
17	06671	Probe, Warrick, 4.313 Long
18	62453	Extension, Water Probe, 1/2 x 4.625
19	62452	Extension, Water Probe, 1/2 x 3.125
20	23151	Washer, Internal Tooth Lock, 1/4
21	19218	Screw, Hex Head, 1/4-20 x 3/8, S/S
22	19288	Screw, Hex Head, 1/4-20 x 3/4, S/S
23	19995	Switch, Low Water Cutoff, California Code
24	02623	Bushing, Hex, 1/4 x 1/4, Brass (California Code Only)
25	05253	Elbow, Street, 1/2, 90°, Brass (California Code Only)



Cleveland Range, Inc.
1333 East 179th St.
Cleveland, OH 44110
Ph: (216) 481-4900 Fax: (216) 481-3782

92/03/28

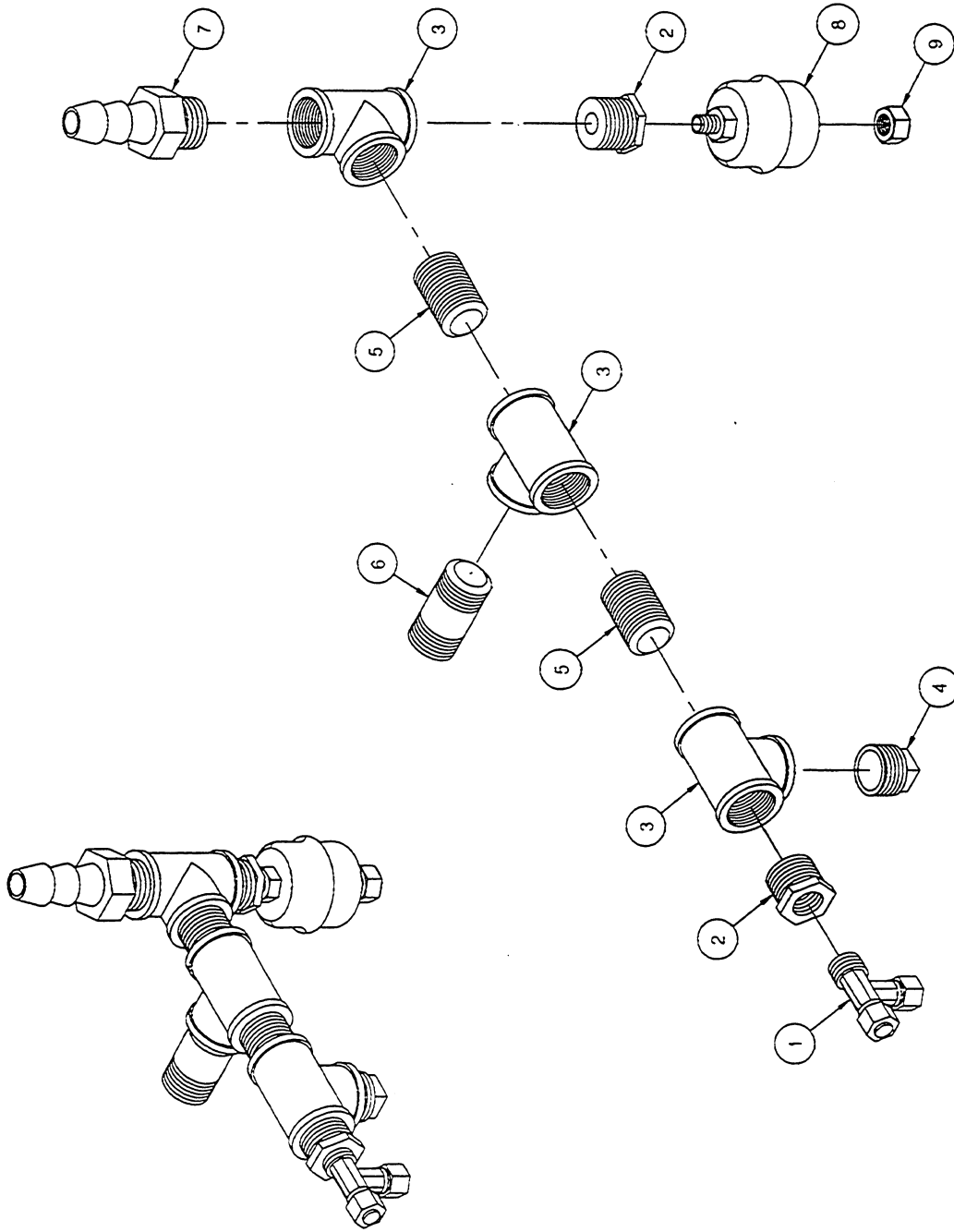

SEE REVERSE SIDE FOR PARTS LIST

Parts List Below Is For Drawing On Previous Page

Item	Part Number	Description
1	100883	Fitting, Comp, Tee, 3/8 T x 3/8 MPT x 3/8 T
2	02563	Bushing, Reducing, 3/4 x 1/4, Brass
3	20206	Tee, 3/4, Brass
4	16607	Plug, Square Head, 3/4, Brass
5	14342	Nipple, 3/4 x Close, Brass
6	14431	Nipple, 3/4 x 2, Brass
7	06240	Fitting, Hose Barb, 3/4 H x 3/4 MPT, Brass
8	101207	Trap, Thermostatic, 1/4 x 1/4
9	14661	Nut, Compression, 1/4 T, Brass



Cleveland Range, Inc.
1333 East 179th St.
Cleveland, OH 44110
Ph: (216) 481-4900 Fax: (216) 481-3782

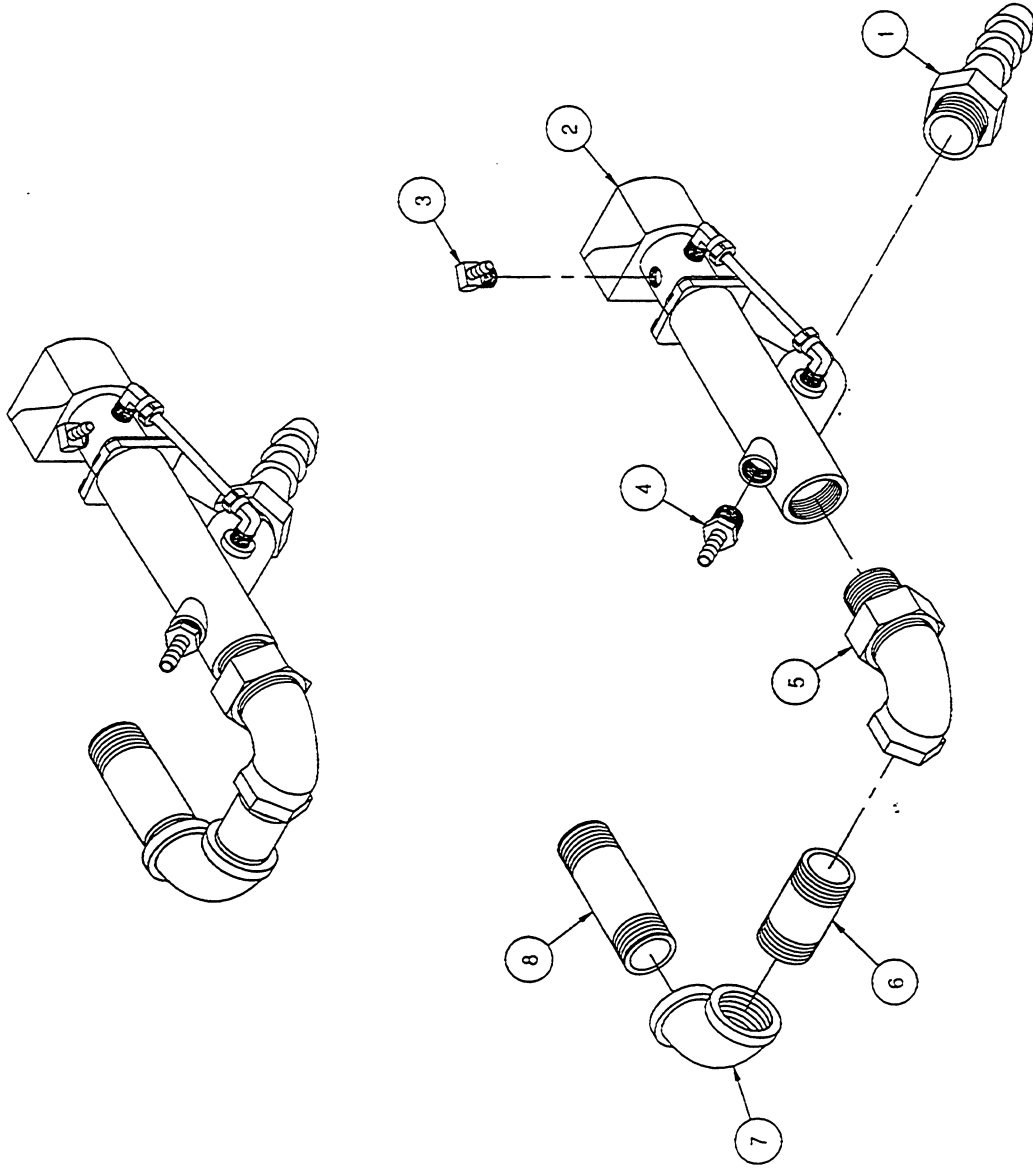

SEE REVERSE SIDE FOR PARTS LIST

CONVECTION PRO 12

Parts List Below Is For Drawing On Previous Page

Item	Part Number	Description
1	06240	Fitting, Hose Barb, 3/4 H x 3/4 MPT
2	22244	Valve, Solenoid, 1/2, 15 PSI
3	105787	Fitting, Hose Barb, 1/4 H x 1/8 NPT, 90°
4	104381	Fitting, Hose Barb, 1/4 H x 1/4 NPT
5	05263	Elbow, Radiator, 3/4 x 90°
6	14431	Nipple, 3/4 x 2, Brass
7	05260	Elbow, 3/4 x 3/4, 90°
8	14495	Nipple, 3/4 NPT x 3, S/S



Cleveland Range, Inc.
1333 East 179th St.
Cleveland, OH 44110
Ph: (216) 481-4900 Fax: (216) 481-3782

92/03/28

★ IF LOW WATER CUTOFF IS USED,
ITEM 24 IS REPLACED WITH AN ITEM 26.

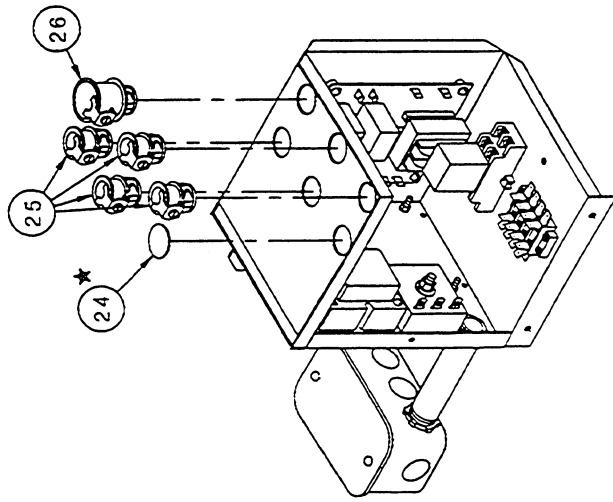

ASSEMBLED VIEW ROTATED 90°
W/ GREENFIELD CONNECTORS

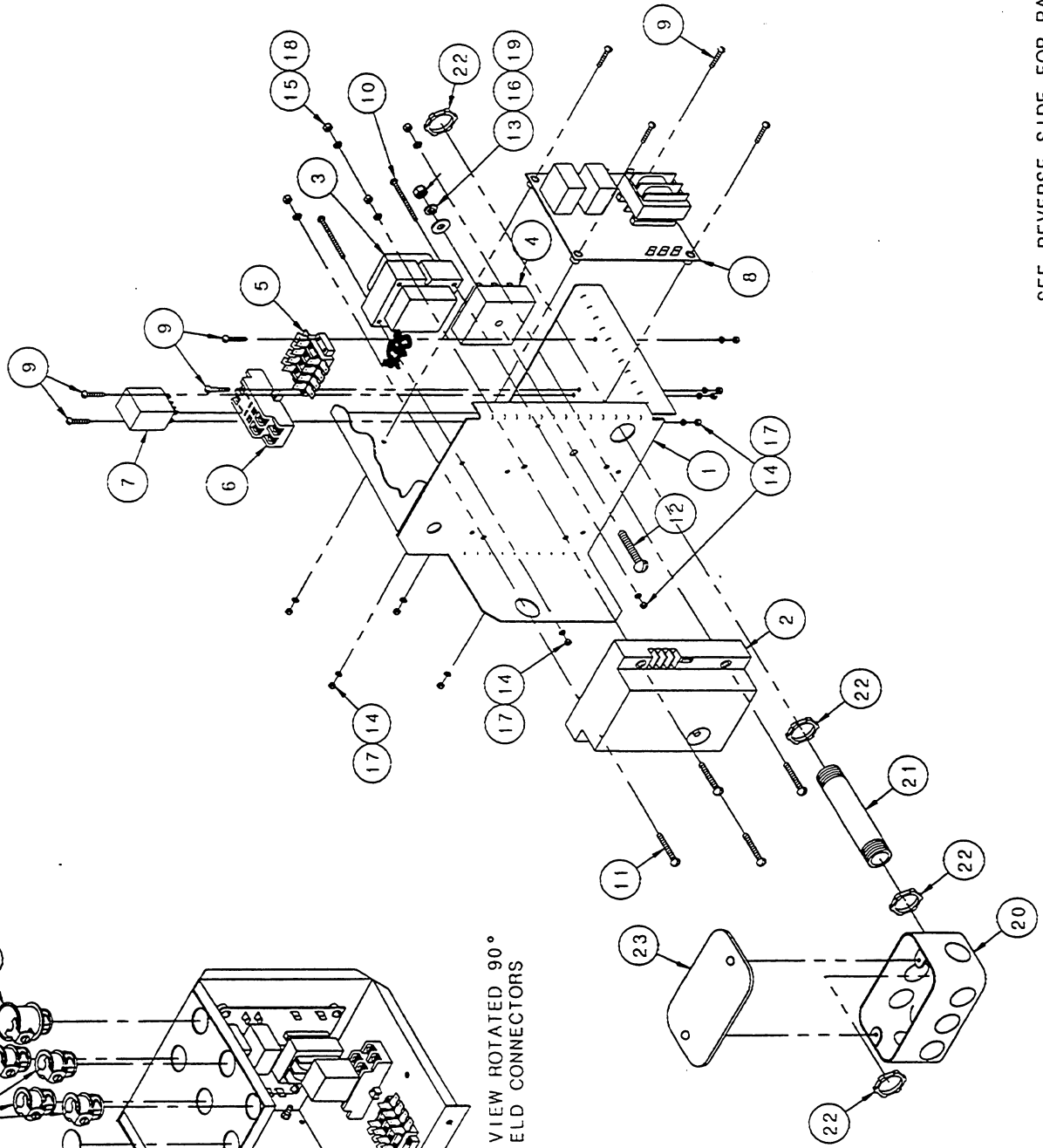

SEE REVERSE SIDE FOR PARTS LIST

Parts List Below Is For Drawing On Previous Page

Item	Part Number	Description
1	44139	Box, Weldment, Electric for Gas, 2 Probe
2	03546	Control Module, Direct Spark Ignition
3	20258	Transformer - Spark Ignition Supply
4	20478	Timer, Solid State Interval, 3 Minute
5	44164	Terminal Block Assembly - 4 Pole, Gas Units
6	03525	Socket, Relay
7	03524	Relay, 120 V, 50/60 Hz, AC, DPDT
8	23198	Control, Water Level
9	19163	Screw, Round Head, Slotted, 6-32 x .75
10	19149	Screw, Round Head, Slotted, 6-32 x 1.75
11	19150	Screw, Round Head, Slotted, 6-32 x 1.25
12	19265	Screw, Round Head, 1/4-20 x 1.5, S/S
13	23116	Washer, Flat, 1/4 ID x .065 Thick
14	23111	Washer, Internal Tooth Lock, #6
15	101337	Washer, Internal Tooth Lock, #8
16	23105	Washer, Split Lock, 1/4, S/S
17	14674	Nut, Hex, 6-32, Zinc Plated
18	14598	Nut, Hex, 8-32, Zinc Plated
19	14618	Nut, Hex, 1/4-20, S/S, Full Finish
20	02361	Box, Handi-Box, Electrical
21	14334	Nipple, 1/2 x 4, Black
22	14614	Nut, Lock, 1/2, Electrical
23	02368	Cover, Handi-Box
24	19329	Plug, Snap-In, 1/2" for 7/8" Hole
25	105243	Connector, Greenfield, 3/8, Snapitite
26	105246	Connector, Greenfield, 1/2, Snapitite



Cleveland Range, Inc.
 1333 East 179th St.
 Cleveland, OH 44110
 Ph: (216) 481-4900 Fax: (216) 481-3782

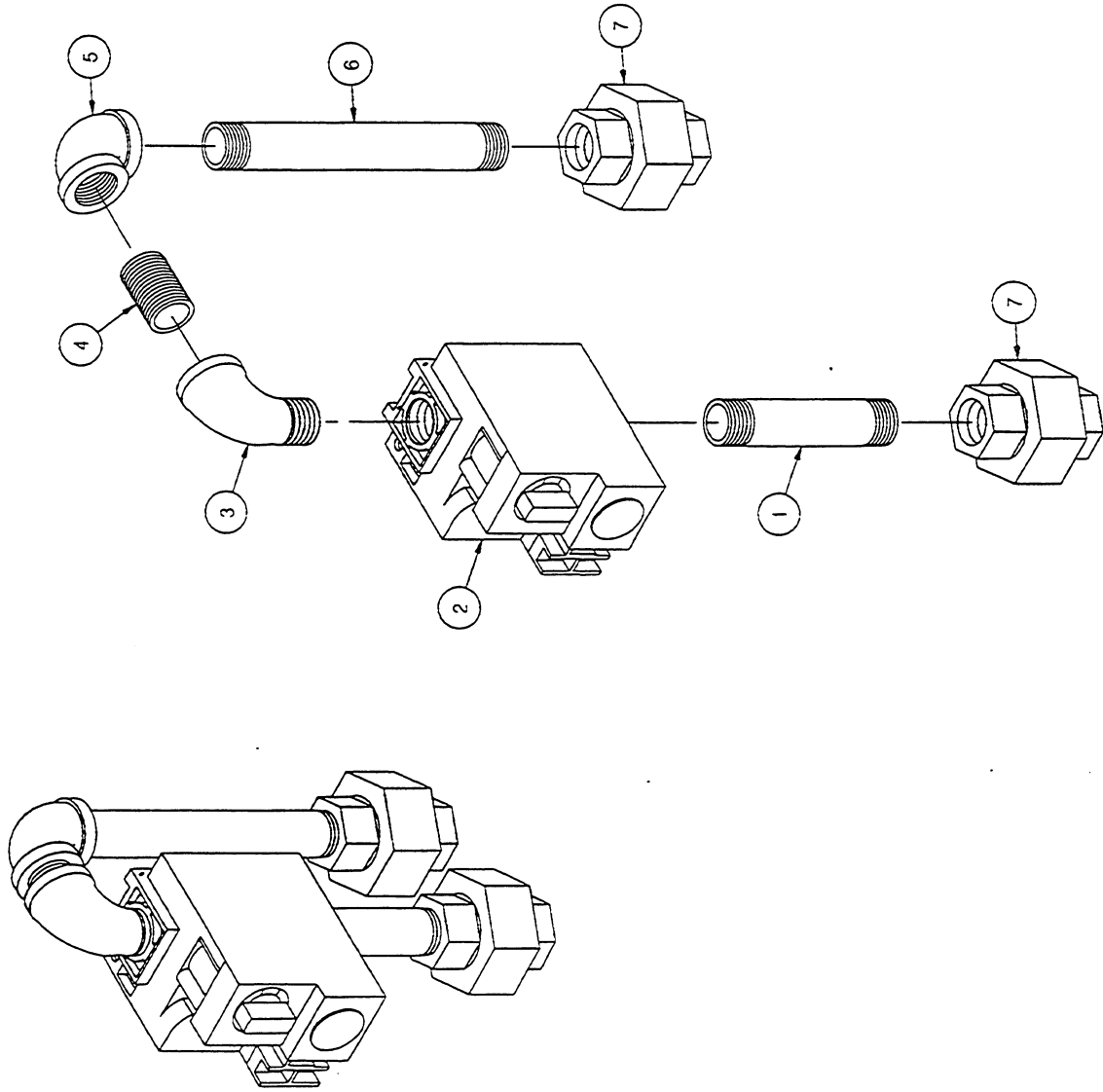

SEE REVERSE SIDE FOR PARTS LIST

Cleveland Convection Pro

Parts List Below Is For Drawing On Previous Page

Item	Part Number	Description
1	14347	Nipple, 3/4 x 3, Black
2	22230	Valve, Gas Control, Natural Gas
	22231	Valve, Gas Control, Liquid Propane
3	05259	Elbow, Street, 3/4, 90°, Black
4	14343	Nipple, 3/4 x Close, Black
5	05258	Elbow, 3/4, 90°, Black
6	14362	Nipple, 3/4 x 7.5, Black
7	21305	Union, 3/4, Black



Cleveland Range, Inc.
1333 East 179th St.
Cleveland, OH 44110
Ph: (216) 481-4900 Fax: (216) 481-3782

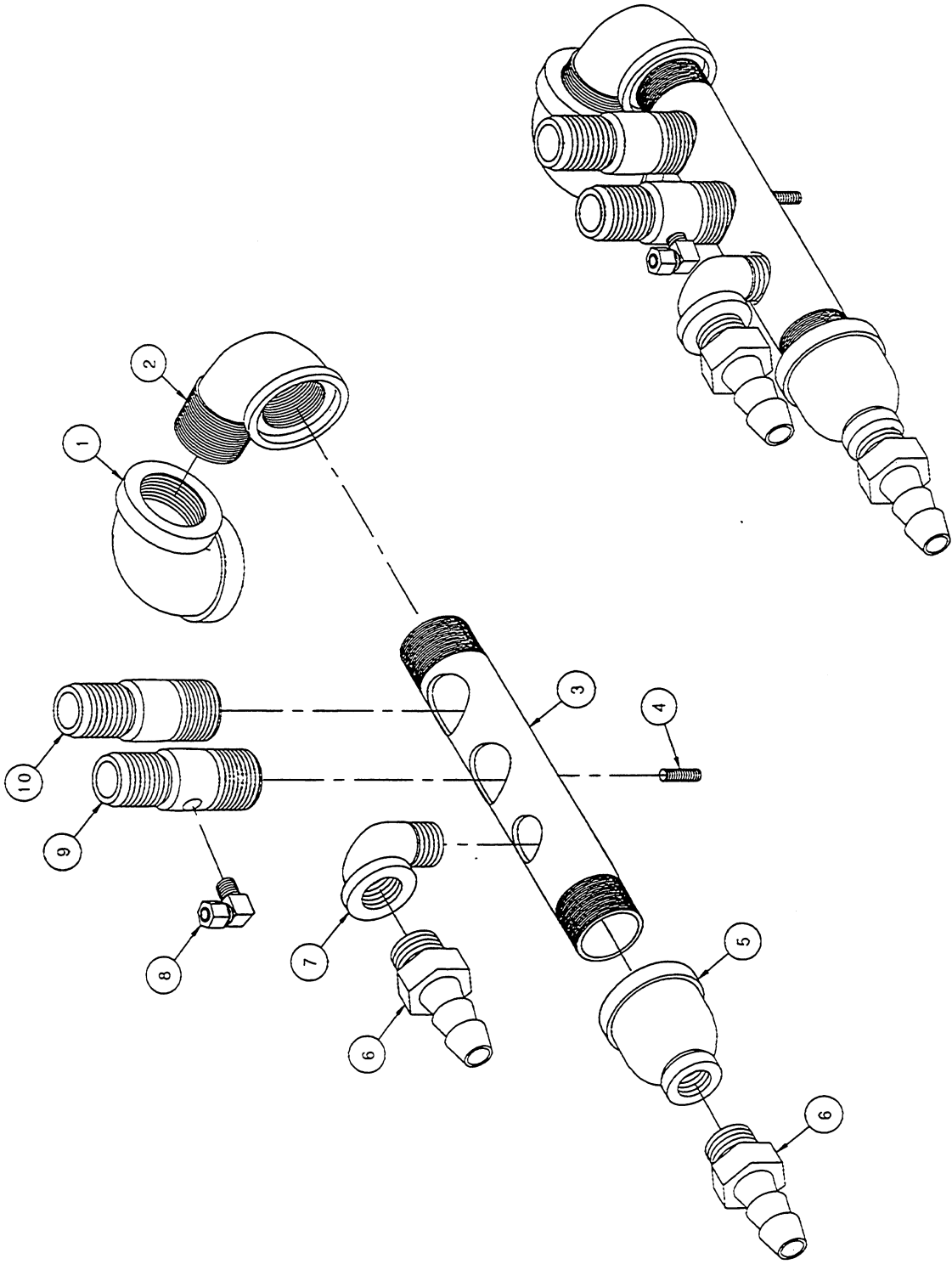

SEE REVERSE SIDE FOR PARTS LIST

Parts List Below Is For Drawing On Previous Page

Item	Part Number	Description
1	05238	Elbow, 1½ NPT x 90°, Black
2	05292	Elbow, Street, 1½ NPT x 90°, Black
3	13252	Manifold, Drain, 1½ NPT, Black
4	19917	Stud, Weld, 1/4-20 x .875, S/S
5	03616	Coupling, Reducing, 1½ x 3/4, Black
6	06240	Fitting, Hose Barb, 3/4 H x 3/4 MPT
7	05259	Elbow, Street, 3/4 x 90°, Black
8	06192	Fitting, Comp, 1/4 T x 1/8 MPT, 90°
9	565191	Fitting, Hose Barb, Drain Manifold with 1/8 Hole
10	14481	Fitting, Hose Barb, 1" H x 1" MPT



Cleveland Range, Inc.
1333 East 179th St.
Cleveland, OH 44110
Ph: (216) 481-4900 Fax: (216) 481-3782

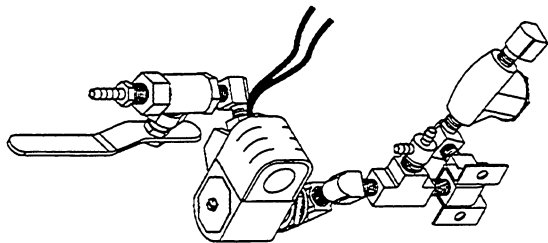
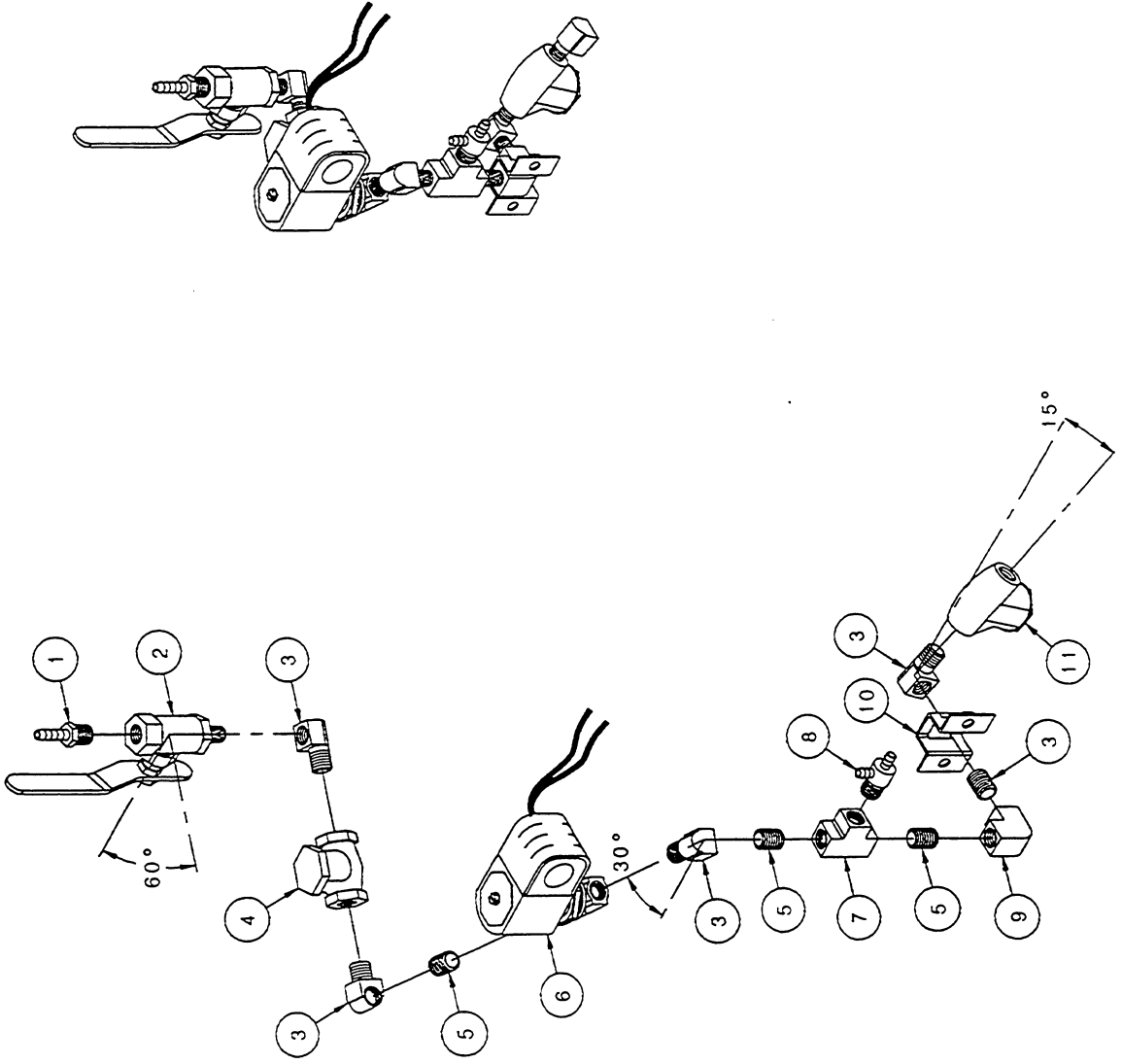

SEE REVERSE SIDE FOR PARTS LIST

Parts List Below Is For Drawing On Previous Page

Item	Part Number	Description
1	104381	Fitting, Hose, 1/4 H x 1/4 NPT
2	03276	Valve Ball, 1/4 NPT
3	05235	Elbow, Street, 1/4, 90°, Brass
4	22102	Valve, Check, 1/4 NPT
5	14304	Nipple, 1/4 x Close, Brass
6	22223	Valve, Solenoid, 1/4 NPT (GP200)
7	20199	Tee, 1/4, Brass
8	106588	Tee, Hose Barb, 1/4, Brass
9	05236	Elbow, 1/4, 90°, Brass
10	100064	Clamp, Mounting
11	19870	Strainer, "V", 1/4, Brass



Cleveland Range, Inc.
1333 East 179th St.
Cleveland, OH 44110
Ph: (216) 481-4900 Fax: (216) 481-3782

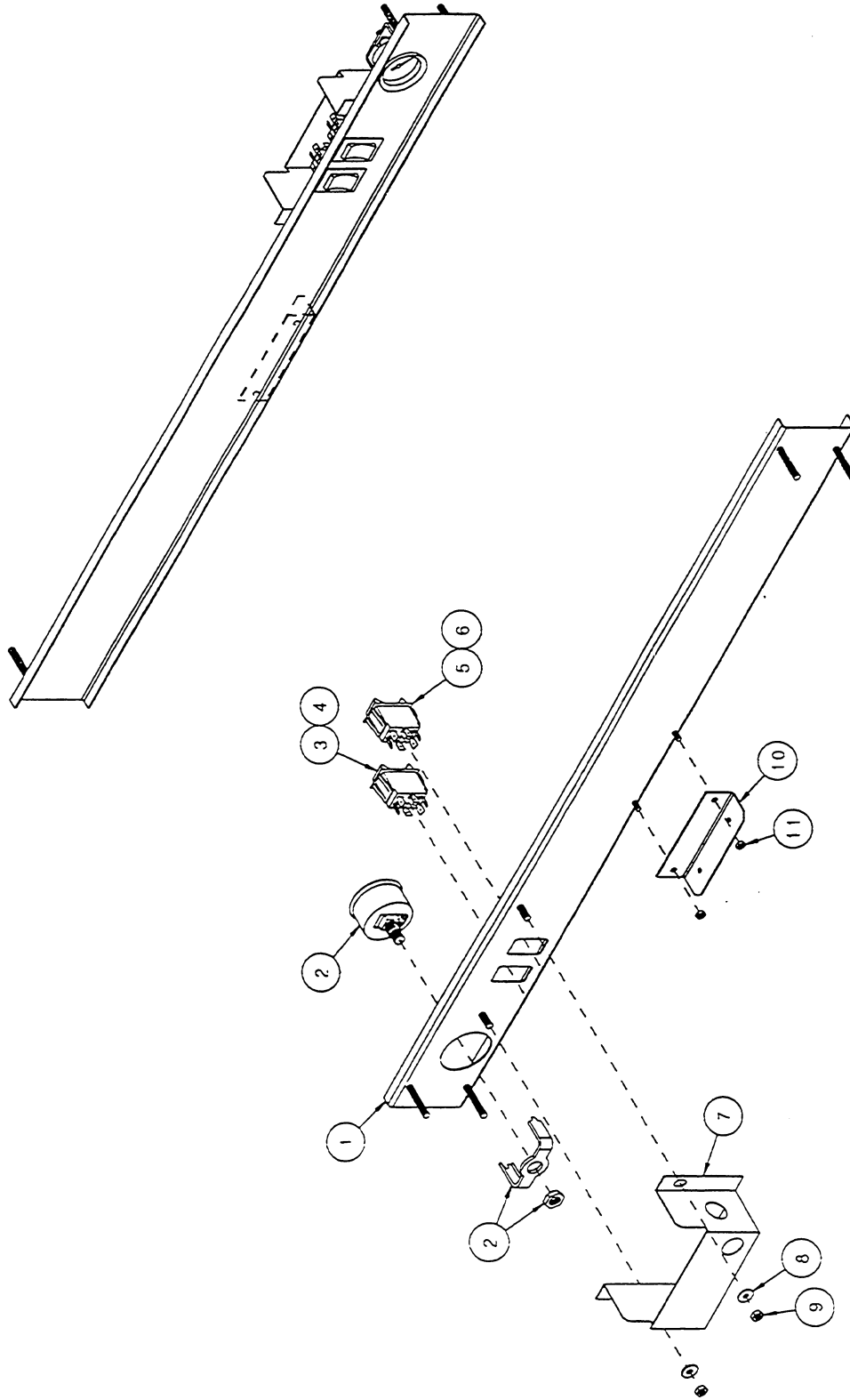

SEE REVERSE SIDE FOR PARTS LIST

Parts List Below is For Drawing On Previous Page

Item	Part Number	Description
1	1041544	Console, Stud Assembly, 900mm, 2 Switch
2	07168	Gauge, Pressure, Back Mount, 10 PSI
3	19994	Switch, Rocker, SPST, 15 Amp
4	15019	Label, Power, Console Switch
5	19993	Switch, Rocker, DPDT, On-Off, 6 Amp
6	15018	Label, Power, Console Switch
7	105516	Box, Switch Protection
8	23116	Washer, Flat, 1/4 ID x 5/8 OD x .065
9	14665	Nut, Hex, Elastic Lock, 1/4-20, S/S
10	102535	Bracket, Magnet Mount
11	14692	Nut, Hex, Elastic Lock, 10-24, Zinc Plated



Cleveland Range, Inc.
1333 East 179th St.
Cleveland, OH 44110
Ph: (216) 481-4900 Fax: (216) 481-3782

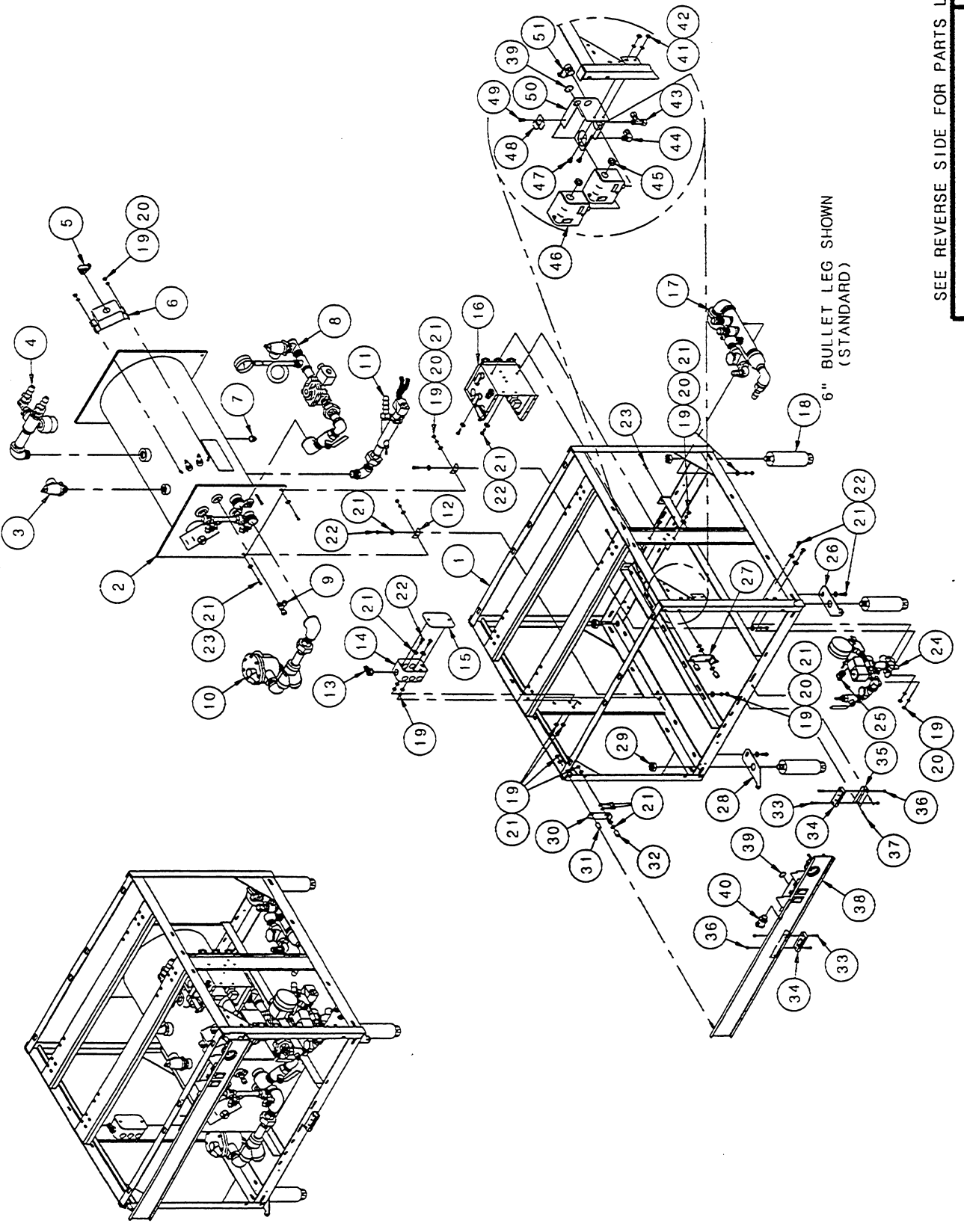

6" BULLET LEG SHOWN
(STANDARD)

SEE REVERSE SIDE FOR PARTS LIST

CONVECTION PRO 18

Parts List Below Is For Drawing On Previous Page

Item	Part Number	Description
1	101692	Base, Weldment, 900mm, S/S
	1016921	Base, Weldment, 900mm, A.C.S.
2	See Sheet 19	Generator Assembly, Large Steam Coil With Reference Parts
3	22131	Valve, Safety, 3/4, 15 PSI, Bronze
4	See Sheet 20	Piping Assembly, Steam Outlet, PCL
5	105245	Connector, Greenfield, 3/8, 90°
6	101112	Box, Probe Cover, Large Steam Coil
7	16602	Plug, Square Head, Cored, 1/2 NPT, Black
8	See Sheet 21	Inlet, Steam Assembly, PCL Steam Coil
9	050073	Fitting, Comp, Tee, 3/8, Brass
10	See Sheet 22	Piping, Steam Outlet, PCL Steam Coil
11	See Sheet 23	Blowdown Assembly, Auto, PCL Steam Coil
12	101893	Bracket, Generator, Mounting, Large Steam Coil
13	105244	Connector, Greenfield, 3/8, 45°
14	02361	Box, Handi-Box, Electrical
15	02368	Cover, Handi-Box
16	See Sheet 24	Box, Electric, Steam Coil with Components
17	See Sheet 25	Drain Manifold Assembly
18	06156	Leg, Bullet, 6"
19	14618	Nut, Hex, 1/4-20, S/S
20	23105	Washer, Lock, 1/4, Katlink Style
21	23116	Washer, Flat, 1/4 x 5/8 x .065
22	19288	Screw, Hex Head, 1/4-20 x 3/4
23	19292	Screw, Round Head, Slotted, 1/4-20 x 1"
24	See Sheet 26	Water Feed Assembly, Reverse Bend Generator, 3/8
25	105243	Connector, Greenfield, 3/8, Straight
26	1020663	Hinge, Lower Right



Cleveland Range, Inc.
 1333 East 179th St.
 Cleveland, OH 44110
 Ph: (216) 481-4900 Fax: (216) 481-3782

Cleveland Convection Pro **Sheet 18 continued**

27	528621	Hinge, Upper Right
28	1020662	Hinge, Lower Left
29	14668	Nut, Hex, Jam, 3/4-10, Zinc Plated
30	528611	Hinge, Upper Left
31	19555	Spacer
32	195552	Spacer
33	19206	Screw, Round Head, 6-32 x 1", Zinc Plated
34	03100	Catch, Latch
35	53274	Clip, Magnet Catch, S/S
36	14674	Nut, Hex, 6-32, Zinc Plated
37	18358	Rivet, 1/8 DIA, Flush Break, S/S
38	See Sheet 17	Console Assembly, 900mm, 2 Catch
39	19329	Plug, Snap-In, 1/2" for 7/8" Hole
40	105246	Connector, Greenfield, 1/2, Straight
41	14688	Nut, Hex, Jam, 1/4-20, S/S
42	23137	Washer, Lock, Internal Tooth, 1/4, S/S
43	100883	Fitting, Comp, Tee, 3/8 x 1/4 Npt x 3/8
44	06196	Fitting, Comp, 3/8 x 1/4 Mpt, 90°
45	02599	Bushing, Insulating, 3/8 x 1/2, Heyco
46	19947	Switch, Pressure Control
47	19218	Screw, Hex Head, 1/4-20 x .375, S/S
48	52499	Bracket, Pressure, Switch Retainer
49	19148	Screw, Hex Washer Head, Slotted
50	526241	Bracket, Pressure Switch, Gas/Electric
51	105247	Connector, 1/2, 90°, Snaptite

Cleveland Range, Inc.
 1333 East 179th St.
 Cleveland, OH 44110
 Ph: (216) 481-4900 Fax: (216) 481-3782



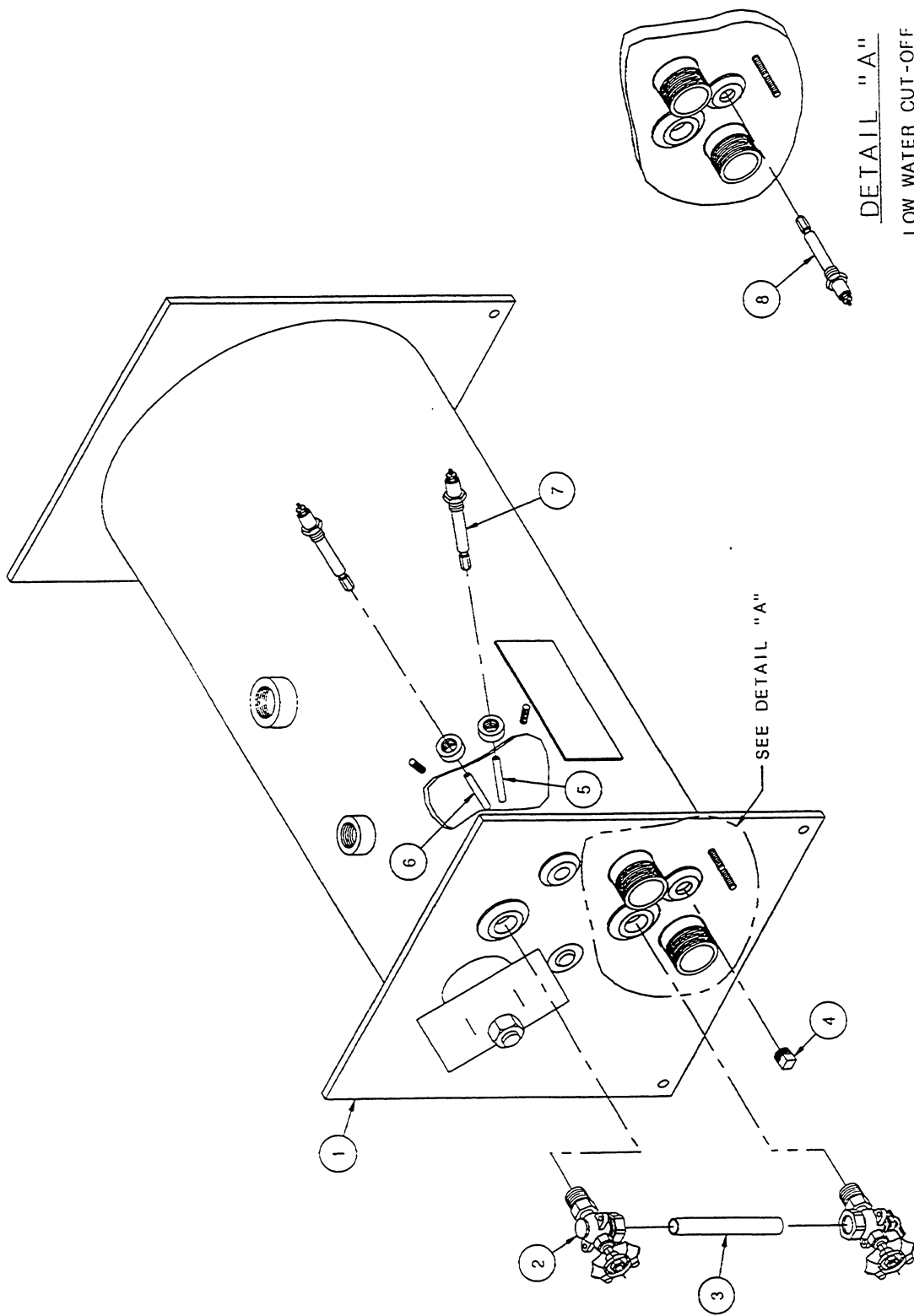

DETAIL "A"

LOW WATER CUT-OFF
CALIFORNIA CODE ONLY

SEE DETAIL "A"

SEE REVERSE SIDE FOR PARTS LIST

Cleveland Convection Pro

Parts List Below Is For Drawing On Previous Page

Item	Part Number	Description
1	101927	Generator Assembly, 2 Probe, Large Steam Coil
2	07176	Gauge Fittings, Water, 1/2
3	101900	Gauge, Water, 5/8 x 4.625, Glass
4	16601	Plug, Square Head, 3/8 NPT, Black
5	101912	Extension, Probe, Low Water, PCL
6	101913	Extension, Probe, High Water, PCL
7	16671	Probe, Warrick, 4.313 Long



Cleveland Range, Inc.
1333 East 179th St.
Cleveland, OH 44110
Ph: (216) 481-4900 Fax: (216) 481-3782

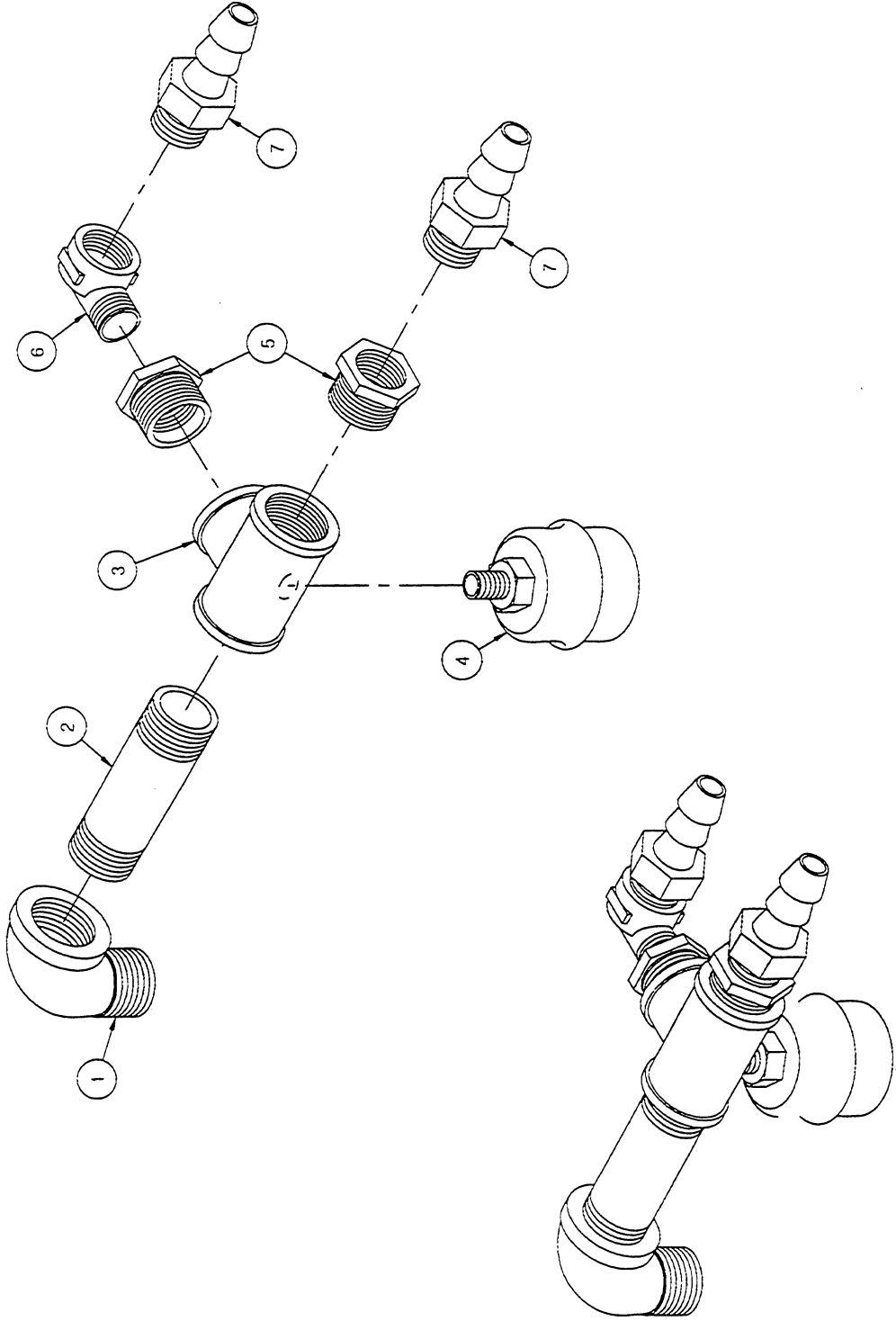

Parts List Below Is For Drawing On Previous Page

Item	Part Number	Description
1	101708	Elbow, Street, 1", 90°, Brass
2	14494	Nipple, 1" x 4, Brass
3	70413	Tee, 1", Brass - Modified (PCL Steam Coil)
4	101207	Trap, Thermostatic, 1/4 NPT
5	02570	Bushing, Hex, 1" x 3/4, Brass
6	05231	Elbow, Street, 3/4, 90°, Brass
7	06240	Fitting, Hose Barb, 3/4 H x 3/4 NPT



Cleveland Range, Inc.
1333 East 179th St.
Cleveland, OH 44110
Ph: (216) 481-4900 Fax: (216) 481-3782

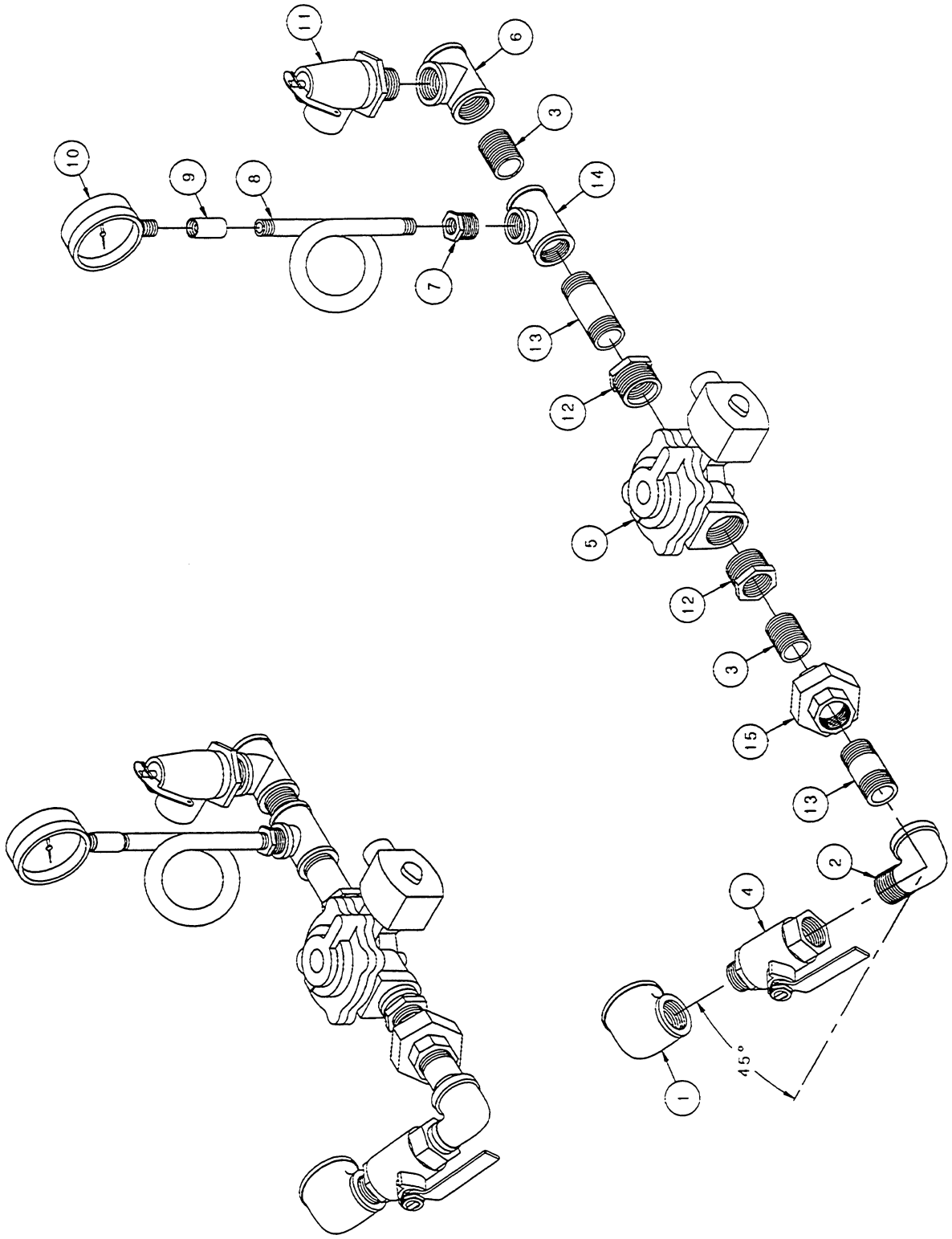

SEE REVERSE SIDE FOR PARTS LIST

Cleveland Convection Pro

Parts List Below Is For Drawing On Previous Page

Item	Part Number	Description
1	05270	Elbow, Street, 1/4 x 3/4, 90°, Black
2	05259	Elbow, Street, 3/4, 90°, Black
3	14343	Nipple, 3/4 x Close, Black
4	03277	Valve, Ball, 3/4, Brass
5	101699	Valve, Steam Solenoid, 1" NPT
6	20205	Tee, 3/4, Black
7	02557	Bushing, 1/2 x 1/4, Black
8	16820	Pipe, Pigtail, 1/4
9	03665	Coupling, Full, 1/4, S/S
10	07169	Gauge, 0-100 PSI, 1/4 NPT
11	100075	Valve, Boiler Safety, 50 PSI
12	02598	Bushing, Hex, 1" x 3/4, Black
13	14344	Nipple, 3/4 x 2, Black
14	20209	Tee, 3/4 x 3/4 x 1/2, Black
15	21305	Union, Pipe, 3/4, Black, No Warwicks



Cleveland Range, Inc.
 1333 East 179th St.
 Cleveland, OH 44110
 Ph: (216) 481-4900 Fax: (216) 481-3782

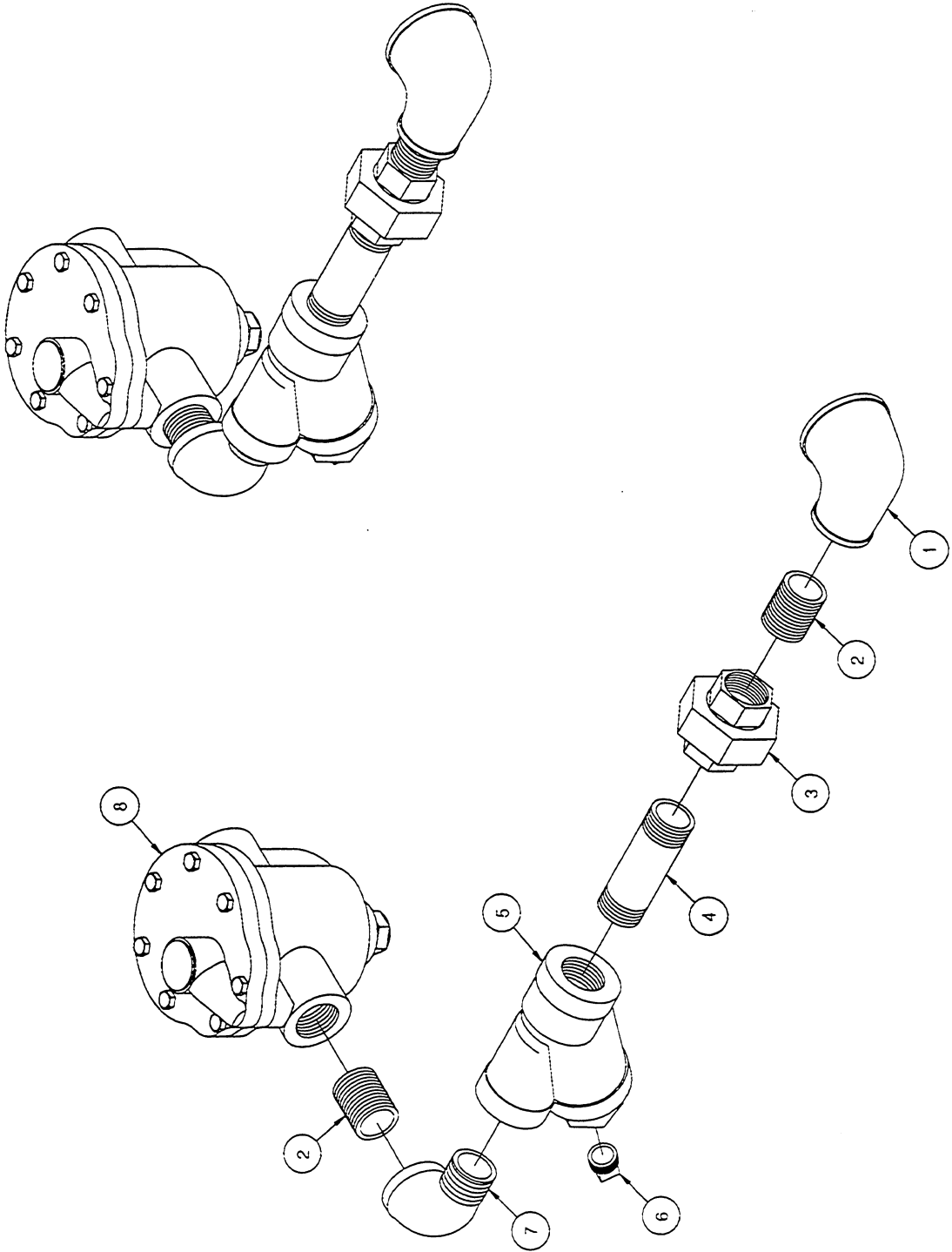

SEE REVERSE SIDE FOR PARTS LIST

Parts List Below Is For Drawing On Previous Page

Item	Part Number	Description
1	05270	Elbow, 1/4 x 3/4, 90°, Black
2	14343	Nipple, 3/4 x Close, Black
3	21305	Union, 3/4, Black
4	14347	Nipple, 3/4 x 3, Black
5	19872	Strainer, "Y", 3/4
6	16602	Plug, Square Head, 1/2, Cored
7	05259	Elbow, Street, 3/4, 90°, Black
8	20555	Trap, Bucket, 60#, 3/4, 80#



Cleveland Range, Inc.
1333 East 179th St.
Cleveland, OH 44110
Ph: (216) 481-4900 Fax: (216) 481-3782

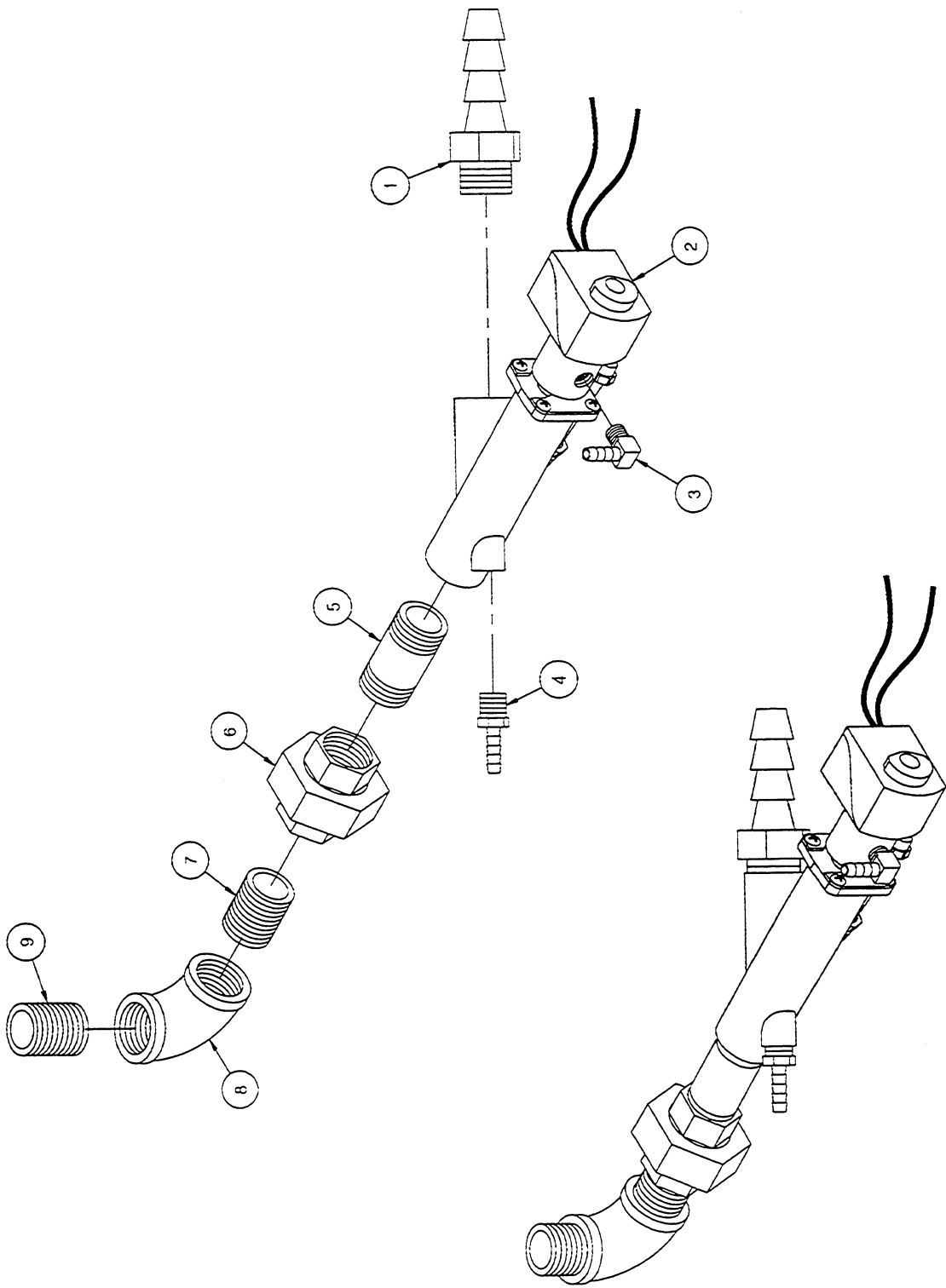

SEE REVERSE SIDE FOR PARTS LIST

Parts List Below Is For Drawing On Previous Page

Item	Part Number	Description
1	06240	Fitting, Hose Barb, 3/4 H x 3/4 MPT
2	22244	Valve, Solenoid, 3/4
3	105787	Fitting, Hose Barb, 1/4 H x 1/8 MPT, 90°
4	104381	Fitting, Hose Barb, 1/4 H x 1/4 MPT
5	14431	Nipple, 3/4 x 2, Brass
6	21304	Union, 3/4, Red Brass
7	14342	Nipple, 3/4 x Close, Red Brass
8	05260	Elbow, 3/4, 90°, Brass
9	14490	Nipple, 3/4 x Close, S/S



Cleveland Range, Inc.
1333 East 179th St.
Cleveland, OH 44110
Ph: (216) 481-4900 Fax: (216) 481-3782

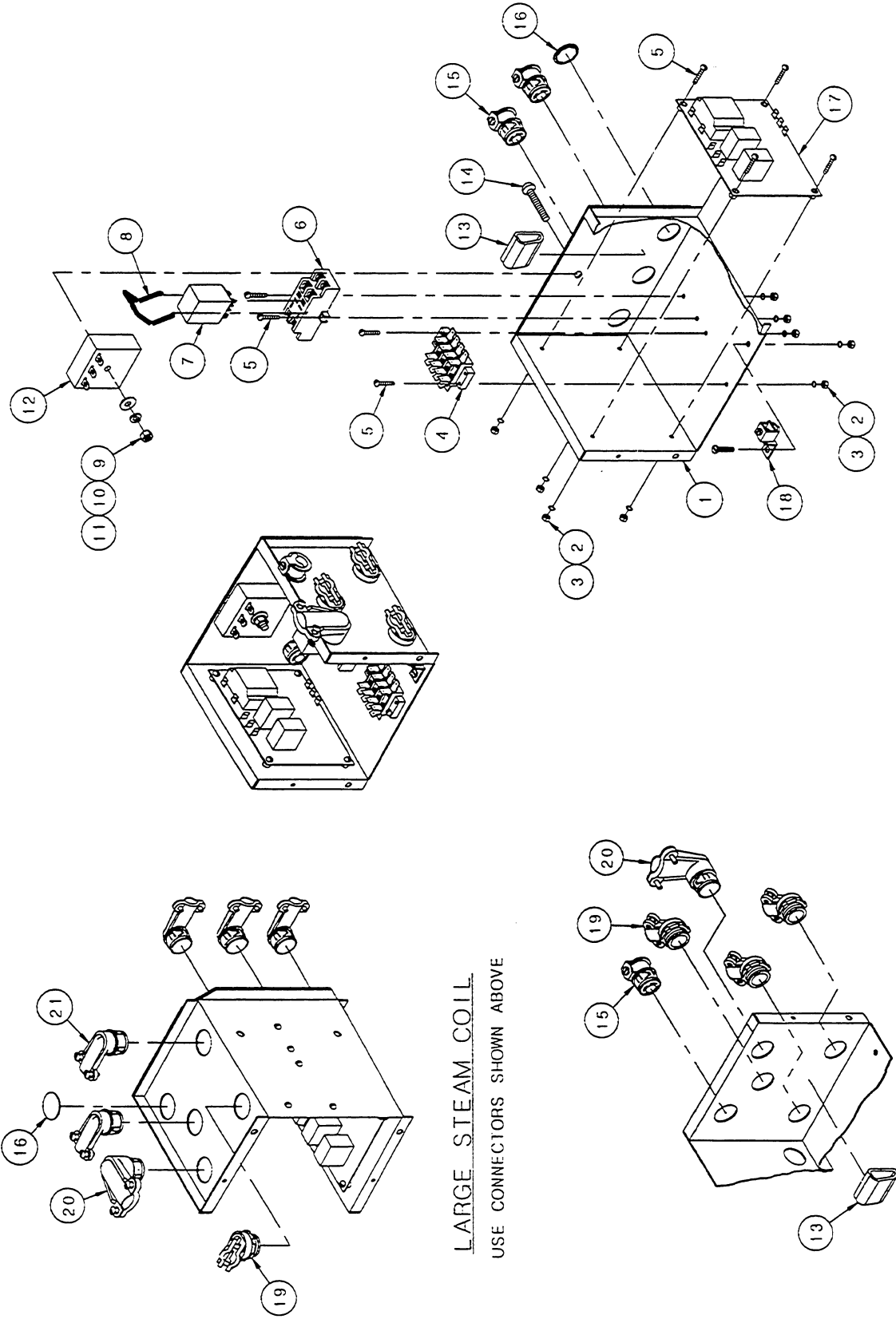

LARGE STEAM COIL

USE CONNECTORS SHOWN ABOVE

INTERIOR RIGHT SIDE VIEW OF ELECTRICAL BOX. ROTATED 90°

SEE REVERSE SIDE FOR PARTS LIST

Cleveland Convection Pro

Parts List Below Is For Drawing On Previous Page

Item	Part Number	Description
1	40939	Box, Weldment, Electrical, Steam Coil Generator
2	14674	Nut, Hex, 6-32, Zinc Plated
3	23111	Washer, Lock, Internal Tooth, #6, Zinc Plated
4	44164	Terminal Block Assembly - 4 Pole
5	19163	Screw, Round Head, Slotted, 6-32 x .75, Zinc Plated
6	03525	Socket, Relay
7	03524	Relay, 120V, 50/60 Hz, AC, DPDT
8	105044	Clip, Wire, Relay
9	14618	Nut, Hex, 1/4-20, S/S, Full Finish
10	23105	Washer, Lock, Medium Pattern, 1/4, Katlink Style, S/S
11	23116	Washer, Flat, 1/4 ID x 5/8 OD x .065
12	20478	Timer, Solid State Interval, 3 Minute
13	23432	Clip, Mounting, Wire/Cable, 1.25 x 1.50
14	19265	Screw, Round Head, 1/4-20 x 1 1/2, S/S
15	105243	Connector, Greenfield, 3/8, Straight
16	19329	Plug, Snap-In, 1/2" for 7/8" Hole
17	23198	Control, Water Level
18	12330	Lug, Solderless Ground for 10-14 Gauge Wire
19	105244	Connector, Greenfield, 3/8 x 45°
20	105247	Connector, Greenfield, 1/2 x 90°
21	105245	Connector, Greenfield, 3/8 x 90°



Cleveland Range, Inc.
 1333 East 179th St.
 Cleveland, OH 44110
 Ph: (216) 481-4900 Fax: (216) 481-3782

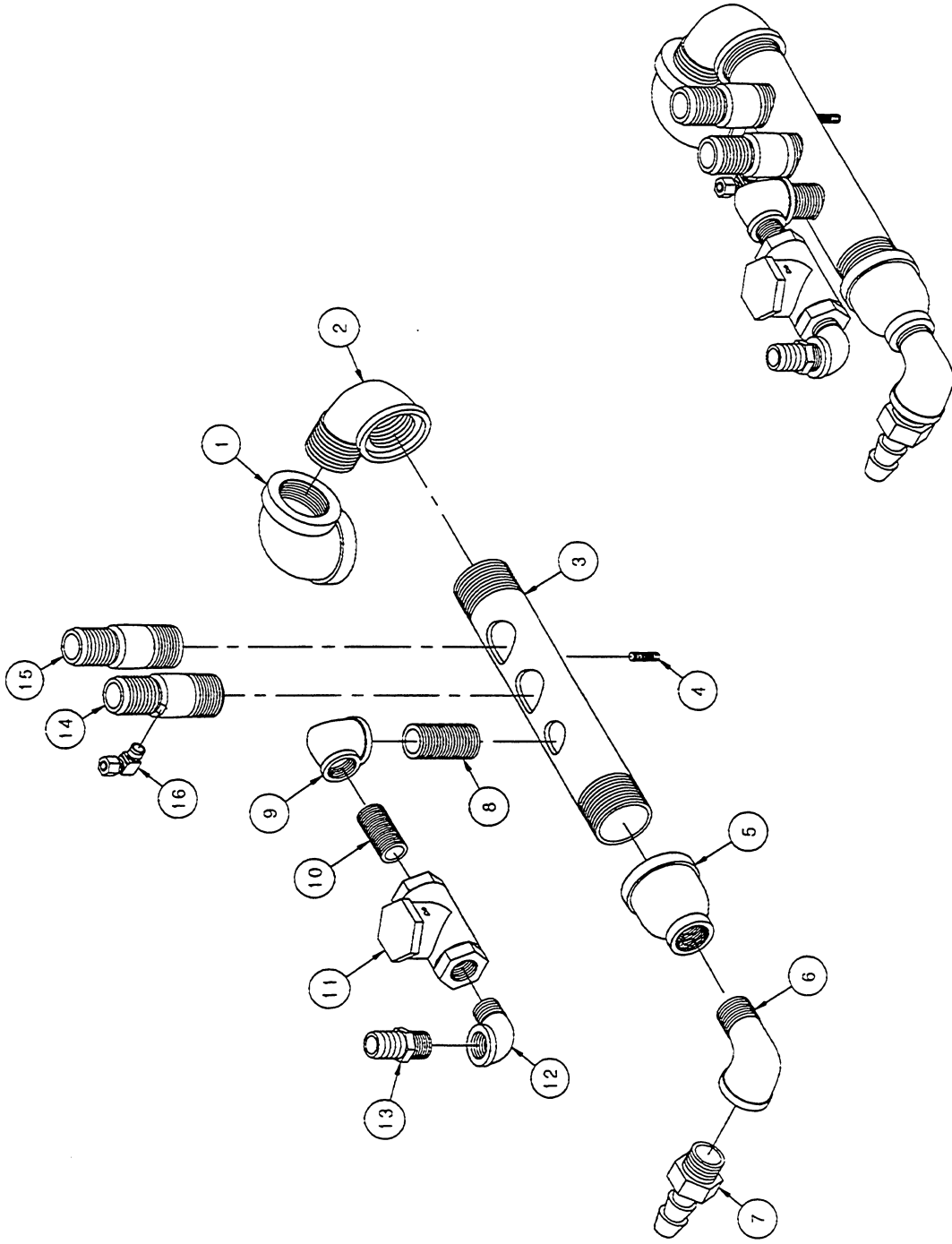

SEE REVERSE SIDE FOR PARTS LIST

Cleveland Convection Pro

Sheet 25

Parts List Below Is For Drawing On Previous Page

Item	Part Number	Description
1	05238	Elbow, 1½ NPT, 90°, Black
2	05292	Elbow, Street, 1½, 90°, Black
3	13252	Manifold, Drain, 1½, Black
4	19917	Stud, Weld, 1/4-20 x 7/8, S/S
5	03616	Coupling, Reducer, 1½ x 3/4, Black
6	05259	Elbow, Street, 3/4, 90°, Black
7	06240	Fitting, Hose Barb, 3/4 H x 3/4 MPT
8	14343	Nipple, 3/4 x Close, Black
9	05271	Elbow, 3/4 x 1/2, 90°, Black
10	14323	Nipple, 1/2 x Close, Black
11	22149	Valve, Swing Check, 1/2, Brass
12	05252	Elbow, Street, 1/2, 90°, Black
13	06241	Fitting, Hose Barb, 3/4 H x 1/2 MPT
14	565191	Fitting, Hose Barb, Drain Manifold with 1/8 Hole
15	14481	Fitting, Hose Barb, 1" H x 1" MPT
16	06192	Fitting, Comp, 1/4 T x 1/8 MPT, 90°



Cleveland Range, Inc.
1333 East 179th St.
Cleveland, OH 44110
Ph: (216) 481-4900 Fax: (216) 481-3782

92/03/28

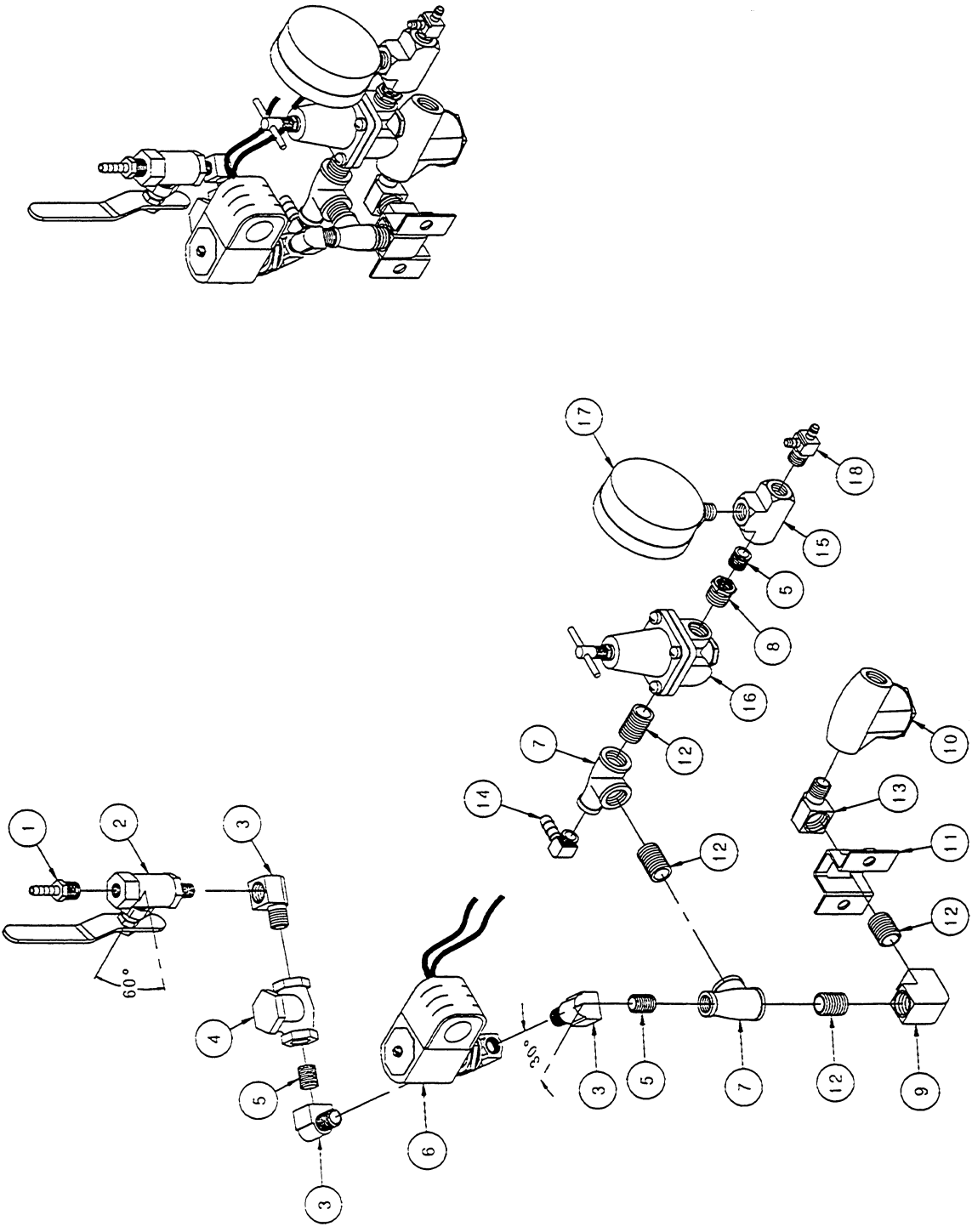

SEE REVERSE SIDE FOR PARTS LIST

Parts List Below Is For Drawing On Previous Page

Item	Part Number	Description
1	104381	Fitting, Hose Barb, 1/4 H x 1/4 NPT
2	03276	Valve, Ball, 1/4 NPT
3	05235	Elbow, Street, 1/4, 90°
4	22102	Valve, Swing Check, 1/4 NPT
5	14304	Nipple, 1/4 x Close, Brass
6	22223	Valve, Solenoid, 1/4 NPT
7	100527	Tee, 3/8 x 1/4 x 3/8, Brass
8	02594	Bushing, 3/8 x 1/4, Brass
9	05244	Elbow, 3/8, 90°, Brass
10	100339	Strainer, "V", 3/8 NPT
11	100303	Clamp, Mounting
12	14427	Nipple, 3/8 x Close, Brass
13	05280	Elbow, Street, 3/8, 90°, Brass
14	105786	Fitting, Hose, 1/4 H x 1/4 MPT, 90°, Brass
15	20199	Tee, 1/4, Brass
16	22239	Valve, Pressure Reducing, Water, 3/8
17	07169	Gauge, Bottom Mount, 0-100 PSI
18	106588	Tee, Hose Barb, 1/4



Cleveland Range, Inc.
1333 East 179th St.
Cleveland, OH 44110
Ph: (216) 481-4900 Fax: (216) 481-3782

ELECTRIC STEAM GENERATOR (BOILER) ASSEMBLY - 2 PROBE TYPE

18 KW, 27 KW, 36 KW, & 48 KW (2, 3, & 4 HEATER ELEMENTS)

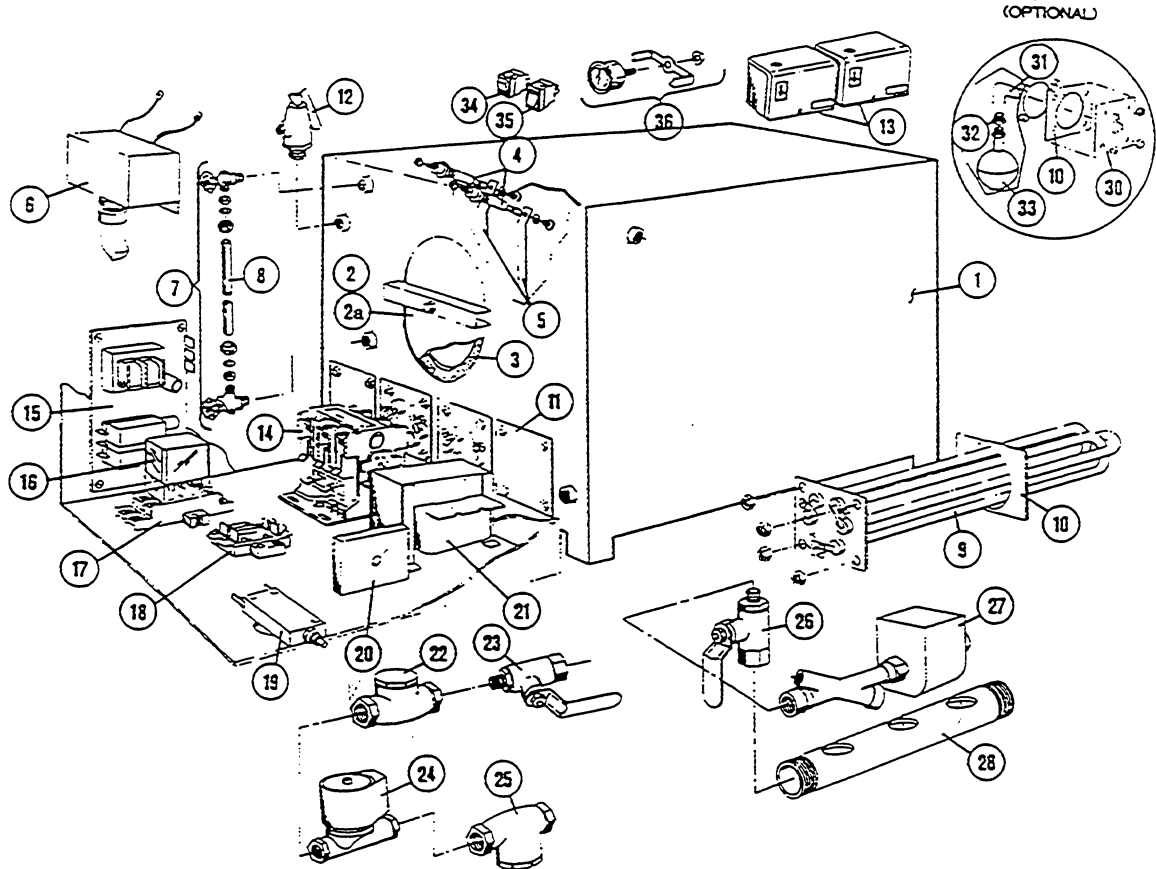

REFERENCE NUMBER	PART NUMBER	DESCRIPTION	REFERENCE NUMBER	PART NUMBER	DESCRIPTION
1	43894	Electric Boiler Shell only, with legs, hand hole plate assembly, mounting studs for 3" square-flanged heater elements		08216	Heater, 12 KW, 440/480 volt, 1 phase
	44149	Electric Boiler Shell (43894) above, also including sight gauge, two probes and extensions with cover box.	10	08217	Heater, 12 KW, 600 volt, 1 phase
2	40421	Hand Hole Plate Assembly including bar, nut, and gasket.	11	07128	Heater Gasket
2a	43748	Hand Hole Plate only	12	16546	3" Block-Off Plate
3	07106	Hand Hole Gasket, 4" x 6" oval	13	22131	15 psi Safety Valve
4	40462	Probe	14	22130	8 psi Safety Valve
5	101466	Probe Extension Set (set of two)	15	19947	Pressure Switch
6	52305	Probe Cover Box	16	03509	Contactor, 50 amp
7	40445	Water Gauge Set with Glass	17	03506	Contactor, 75 amp
	07108	Fibre Washer (2 required)	18	23198	Control Board, water level and LWCO
	23132	Gauge Glass Washer (2 required)	19	03524	Relay
8	07302	Gauge Glass Only, 6" long	20	03525	Relay Socket
9	08235	Heater, 9 KW, 208 volt, 3 phase	21	44168	Terminal Block, 2 pole
	08236	Heater, 9 KW, 220/240 volt, 3 phase	22	03202	Circuit Breaker, 1 amp
	08237	Heater, 9 KW, 440/480 volt, 3 phase	23	20478	Interval Timer, 3 minute
	08234	Heater, 9 KW, 600 volt, 3 phase	24	20535	Transformer, 150 VA
	08241	Heater, 9 KW, 208 volt, 1 phase	25	22102	Check Valve, 1/4"
	08242	Heater, 9 KW, 220/240 volt, 1 phase	26	03276	1/4" Ball Valve, water supply shut-off
	08243	Heater, 9 KW, 440/480 volt, 1 phase	27	22223	Solenoid Valve, water feed
	08244	Heater, 9 KW, 600 volt, 1 phase	28	19870	Line Strainer, 1/4"
	08165	Heater, 12 KW, 208/220 volt, 3 phase	29	03277	1/4" Ball Valve, manual drain
	08166	Heater, 12 KW, 230/240 volt, 3 phase	30	22221	Solenoid Valve, boiler drain
	08167	Heater, 12 KW, 440/480 volt, 3 phase	31	13252	Drain Manifold
	08163	Heater, 12 KW, 600 volt, 3 phase	32	45006	Low Water Cut-Off Assembly (California only)
	08214	Heater, 12 KW, 208/220 volt, 1 phase	33	41943	LWCO Mounting Plate (California only)
	08215	Heater, 12 KW, 230/240 volt, 1 phase	34	05253	Brass Street Elbow (California only)
			35	02623	Reducing Bushing, 1/2" - 1/4" (California only)
			36	19995	Float Switch, LWCO (California only)
				19993	DPDT Power switch
				19994	SPST Momentary contact reset switch
				07167	Pressure gauge, 0-30 psi, 1 1/2"

Manufacturer reserves right of design improvement or modification, as warranted.

HEATER AND CONTACTOR WIRING SCHEMATICS FOR SOLID STATE ELECTRIC STEAM GENERATORS

<p>18KW-208V, 220V & 240V-1 PHASE</p> <p>2-HEW HEATERS</p>	<p>36KW-440V, 480V-3 PHASE</p> <p>3-HEW HEATERS</p>																																																
<p>18KW-440V, 480V-1 PHASE</p> <p>2-HEW HEATERS</p>	<p>48KW-208V, 220V, 240V-3 PHASE</p> <p>4-HEW HEATERS</p>																																																
<p>18KW-208V, 220V, 240V, 440V, 480V-3 PHASE</p> <p>2-HEW HEATERS</p>	<p>48KW-208V-3 PHASE</p> <p>4-HEW HEATERS</p>																																																
<p>27KW-208V, 240V-3 PHASE</p> <p>3-HEW HEATERS</p>	<p>48KW-440V, 480V-3 PHASE</p> <p>4-HEW HEATERS</p>																																																
<p>27KW-220V, 440V, 480V-3 PHASE</p> <p>3-HEW HEATERS</p>	<p>36KW-208V, 220V, 240V-3 PHASE</p> <p>3-HEW HEATERS</p>																																																
<p>ELECTRIC POWER</p> <table border="1" style="margin-left: auto; margin-right: auto;"> <thead> <tr> <th rowspan="2">KW</th> <th colspan="5">3 PHASE</th> <th>1 PHASE</th> </tr> <tr> <th>16</th> <th>27</th> <th>36</th> <th>48</th> <th>18</th> </tr> </thead> <tbody> <tr> <td>208V</td> <td>80</td> <td>78</td> <td>100</td> <td>118</td> <td>87</td> </tr> <tr> <td>220V</td> <td>40</td> <td>60</td> <td>80</td> <td>124</td> <td>88</td> </tr> <tr> <td>230V</td> <td>—</td> <td>—</td> <td>—</td> <td>110</td> <td>—</td> </tr> <tr> <td>240V</td> <td>44</td> <td>66</td> <td>87</td> <td>114</td> <td>78</td> </tr> <tr> <td>440V</td> <td>20</td> <td>30</td> <td>40</td> <td>63</td> <td>36</td> </tr> <tr> <td>480V</td> <td>22</td> <td>33</td> <td>44</td> <td>66</td> <td>36</td> </tr> </tbody> </table> <p>FOR POWER SUPPLY CONNECTIONS USE COPPER WIRE ONLY, SUITABLE FOR AT LEAST 75°C.</p>		KW	3 PHASE					1 PHASE	16	27	36	48	18	208V	80	78	100	118	87	220V	40	60	80	124	88	230V	—	—	—	110	—	240V	44	66	87	114	78	440V	20	30	40	63	36	480V	22	33	44	66	36
KW	3 PHASE					1 PHASE																																											
	16	27	36	48	18																																												
208V	80	78	100	118	87																																												
220V	40	60	80	124	88																																												
230V	—	—	—	110	—																																												
240V	44	66	87	114	78																																												
440V	20	30	40	63	36																																												
480V	22	33	44	66	36																																												

Manufacturer reserves right of design improvement or modification, as warranted.

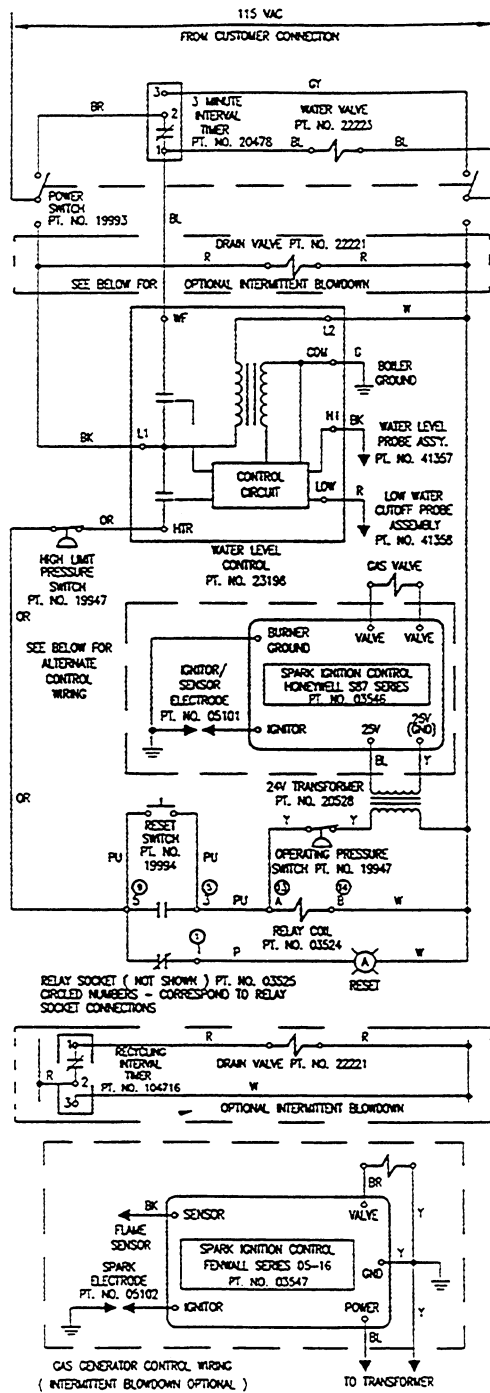

Gas Models

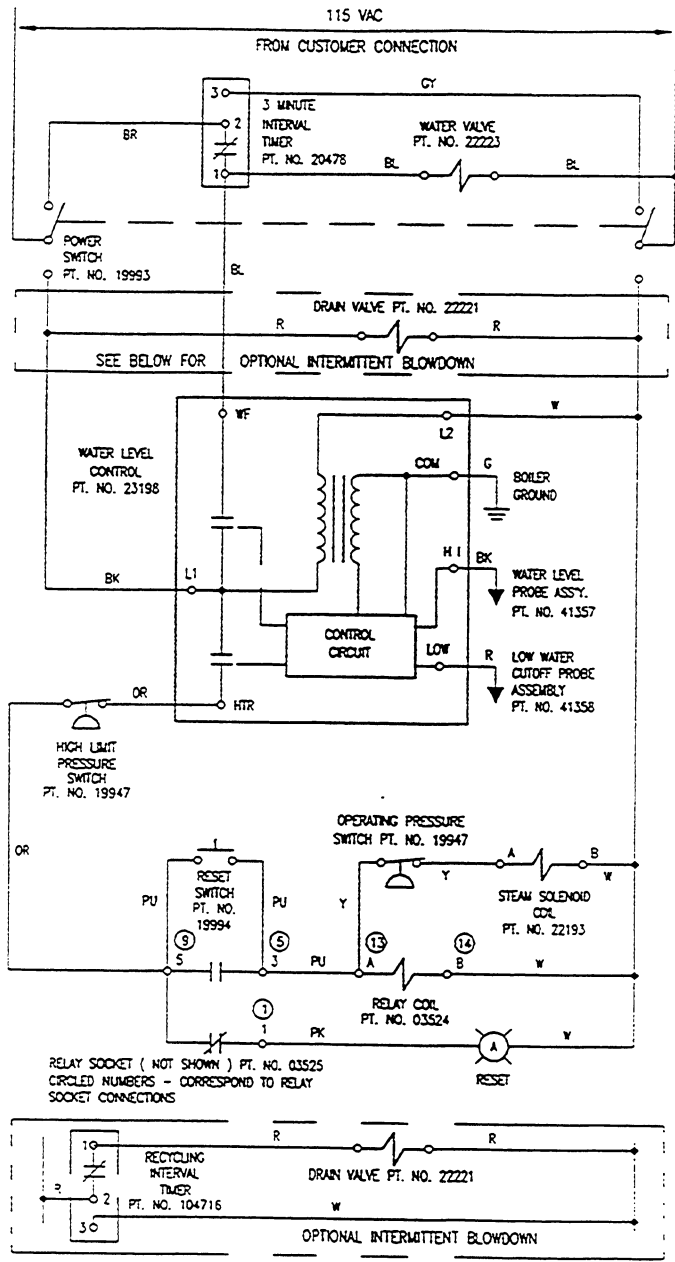

STEAM COIL GENERATOR CONTROL WIRING
(INTERMITTENT BLOWDOWN OPTIONAL)

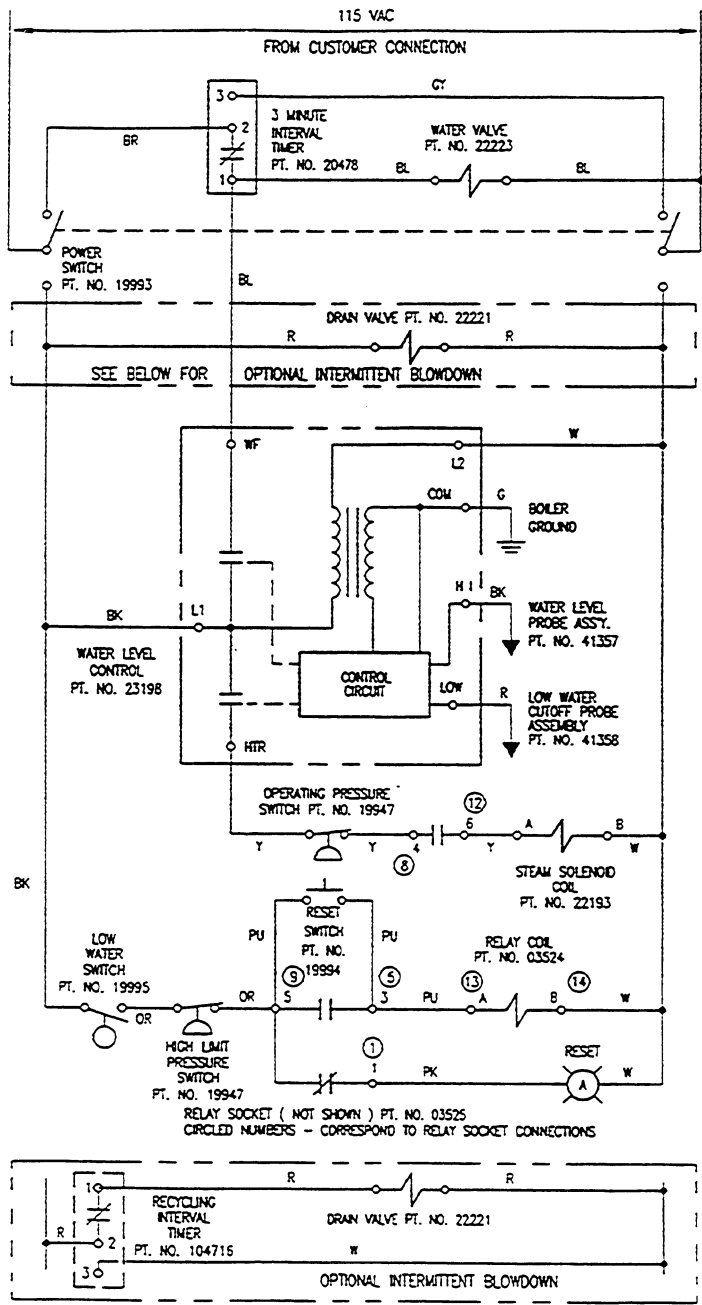

STEAM COIL GENERATOR CONTROL WIRING
SECONDARY LOW WATER CUTOFF
(INTERMITTENT BLOWDOWN OPTIONAL)

Steam Coil Models with Secondary Low Water Cutoff

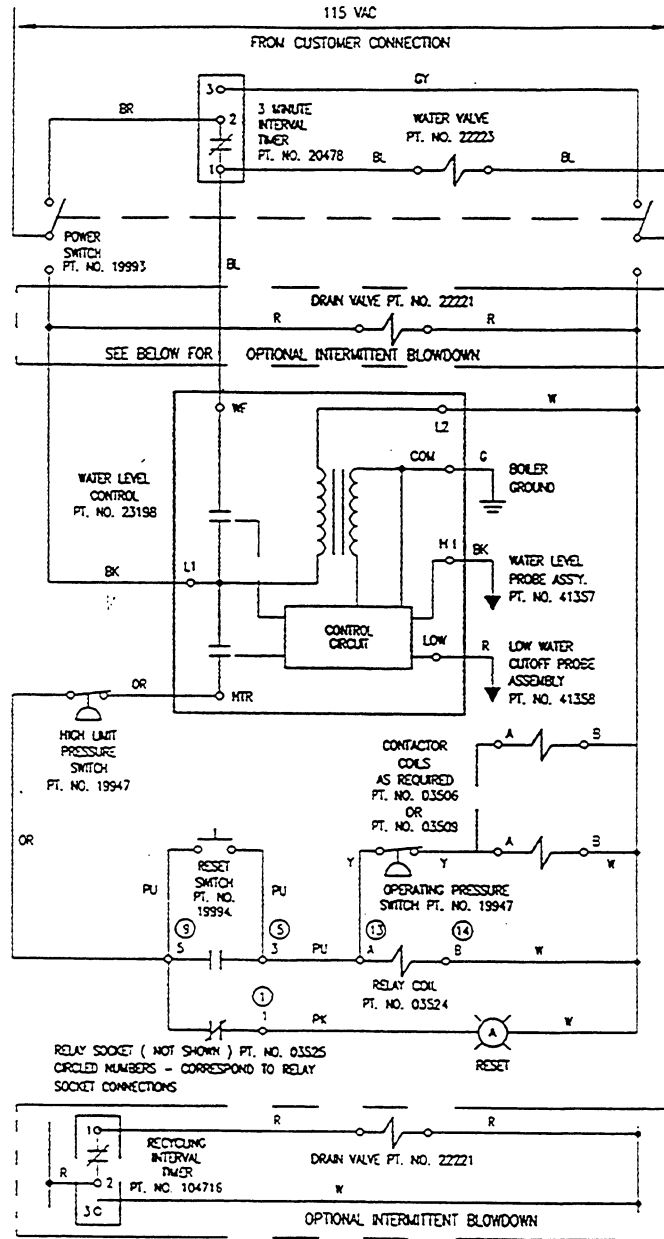

ELECTRIC GENERATOR CONTROL WIRING
(INTERMITTENT BLOWDOWN OPTIONAL)

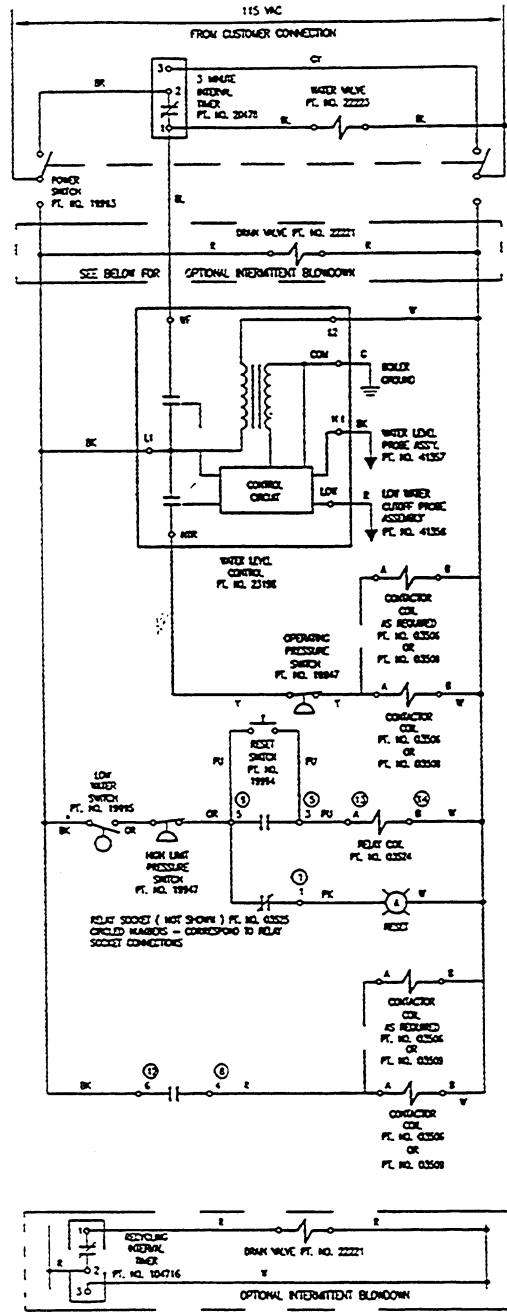

ELECTRIC GENERATOR CONTROL WIRING
 CALIFORNIA CODE
 (INTERMITTENT BLOWDOWN OPTIONAL)

Electric Models with Secondary Low Water Cutoff Built to California Code

PRE-INSTRUCTIONS FOR THE LIQUID
DESCALING OF BOILER BASE UNITS

PART NUMBER 106174

Enclosed is our latest instructions for the newest liquid chemical descaler. Please note: **THIS CHEMICAL IS DESIGNED TO BE USED WITHOUT ANY HEAT APPLIED.** This chemical can now be used for the two and three probe boiler base units. Because the chemical is used without heat, there are some changes in the instructions. They are as follows:

1. The bottle of our latest liquid descaler has a flip up spout in it like a shampoo or liquid soap bottle.
2. The design of the bottle and the fact we can not pour the liquid into the generator through the hand hole plate means you need to build a special tool. We recommend you use about 24 inches of 1/4" O.D. flexible tubing attached to a funnel. Remove the needle valve in the upper sight gauge valve and insert this tube into the generator about 2" inches. Pull the funnel and tubing out front of and above the top of the generator. Pour the liquid into the funnel.
3. On the right side of the two probe generator is a steam trap. The bottom connection must be removed and capped so the liquid does not flow through it.
4. Depending on the style of drain valve and if the unit has a TDS timer, there are different wiring procedures.
5. The lower compartment steam solenoid valve must be open during the filling of the generator to allow any air in the top of the generator to escape.
6. Upon completion of the descale, check the top of the generator to make sure the chemical has cleaned it.

If there are any questions or problems concerning these procedures, please let us know right away at 1-800-338-2204.

DESCALE PROCEDURE FOR
TWO & THREE PROBE GENERATOR BASE STEAMERS

STEP BY STEP PROCEDURE

IMPORTANT WARNING: BEFORE REMOVING THE HAND HOLE PLATE TO DESCAL ANY STEAM GENERATOR, MAKE SURE THERE IS NO WATER OR PRESSURE BUILT UP IN THE GENERATOR. CHECK THE OUTER SURFACE OF THE GENERATOR TO MAKE SURE IT IS COLD. TURN THE YELLOW HANDLE ON THE MANUAL FILL VALVE 90 DEGREES TO THE BODY TO PREVENT ANY WATER FROM ENTERING THE UNIT. THIS LIQUID DESCALER IS DESIGNED TO BE USED WITH NO HEAT APPLIED TO THE GENERATOR.

STEP #1

Before opening the hand hole plate in the generator make sure the red power switch is in the off position. Open the electric circuit box in front of the generator and look for two black square solid state timers mounted on the side. If there are two solid state timers in the box, this unit has a TDS blowdown. The timer mounted on top is a one second timer.

1. IF THE UNIT HAS AN ASCO DRAIN SOLENOID VALVE, remove the white wire from the terminal marked number 3 on the TDS timer to prevent the purge from coming on.
2. IF THE UNIT HAS A PARKER DRAIN SOLENOID VALVE, remove the red/white wire from the terminal marked number 2 on the TDS timer and attach it to L2 on the terminal block.

To open the hand hole plate, loosen and remove the nut and bar across the generator opening. Place the end of a two by four on the hand hole plate. Rap the end of the wood with a hammer in various places until the plate and gasket fall inside the generator.

Remove any scale build-up that can be taken out by hand or with a small vacuum cleaner. IF THE GENERATOR HAS PREVIOUSLY BEEN REPLACED WITH A NICKEL PLATED ONE, DO NOT SCRAPE OR SCRATCH THE SURFACE. Assess the scale build-up above the water level on the tubes and the top to determine the number of descalings that will be needed.

Use 2 quarts of liquid cleaner regardless of the size of the boiler. If there is a heavy build-up of scale (1/4" or more) on the upper tubes (above the water level) and across the top of the generator, it will have to be descaled twice.

After removing the scale and determining the number of descalings needed, replace the hand hole plate with the old gasket still on the plate.

Because the chemical is designed to work with no heat applied, the steam trap on the right side of the new two probe boiler must be closed. Remove the bottom fitting and cap the outlet side.

STEP #2

Remove the needle valve from the top of the sight gauge located on the front of the generator. This will be the port of entry for the liquid descaling agent. **REMEMBER TO MOVE THE YELLOW HANDLE ON THE WATER FILL VALVE TO ALIGN WITH THE VALVE BODY.** Before applying the descaler, turn on the power switch to close the drain valve. This will also energize the fill valve.

STEP #3

Using the special funnel and tubing you assembled, squeeze the liquid into the generator through the port the needle valve was removed from.

STEP #4

After the descaling agent has been introduced into the generator, replace the needle valve.

1. Place the lower compartment timer switch in the manual position. As the generator is filling with water, this will allow any air in the top to escape.
2. To completely fill the generator with water, bypass the water level probe:
 - a. Remove the black wire at the terminal marked HI on the water level control board that connects to the water level probe.
 - b. When the water begins to enter the lower cooking compartment, **CAREFULLY** replace the black wire on the water level control. This will turn the water off.
3. Turn the lower compartment switch back to the timed setting.

STEP #5

DO NOT PRESS THE AMBER STEAM SWITCH. THIS CHEMICAL WORKS BEST WHEN HEAT IS NOT APPLIED.

STEP #6

Wait one hour to allow for descaling of the generator. Drain the generator by turning off the red POWER switch. The drain and fresh water solenoid valves will open for three minutes allowing the generator to flush out. After draining, fill the generator with fresh water and repeat the flush process by turning off the power switch.

STEP #7

After the generator has been rinsed out, remove the hand hole plate and gasket as explained in STEP #1. Observe the edges and surfaces of the hand hole and the plate for excessive wear and corrosion. Replace the used hand hole plate gasket with a new one and install new corrosion resistors.

For the corrosion resistors to work properly, the hanger must be firmly connected to the support rod. Make sure no scale or debris is between the support and the hanger. It must be a metal to metal connection. There are some two probe generators with no support rods. Lay the corrosion resistors on the floor of the generator. If the generator is an electric and there are no support rods do not leave the resistors in it. They may come to rest against the elements and ground them out.

Do not use a gasket sealing material on the hand hole plate gasket. When tightening the nut on the bar, make sure that at least 1/16" of gasket material is showing on the hand hole plate around the inside of the hand hole.

Reinstall the wire removed from the purge timer in the electric box.

STEP #8

Bring the steamer up to pressure by pressing the red power switch to fill the generator and then the amber switch when the light comes on. After twenty (20) minutes the generator should have steam in it. Check for steam leaks around the hand hole. If any leaks are found repeat the process for replacing the gasket.

WATER LEVEL CONTROL SYSTEM

TROUBLESHOOTING AND REPAIR

General Description of Operation:

The Cleveland Range water level control, P/N 23198, is designed to maintain operating water level in Cleveland Range steam generators and to ensure that the heat source is only operated when the generator water level is above a specified minimum level. The sensing technique for the control relies on the fact that tap water is conductive to electricity; if two metal electrodes are immersed in a bath of water, electric current can flow between the electrodes using the water as a conductor. Water is not a good conductor, like copper, but is conductive enough to be measured using appropriate electronic circuitry.

The Cleveland Range control is a two probe system having two metallic probes (LOW and HI) for sensing water in the generator; a COM terminal is placed on the tank. The LOW probe is placed so that it will come in contact with the water when the water level is just above the desired water level, enough to protect the heat source. If the water is of sufficient level and the LOW probe is in the water, a small electrical current provided by the level control electronics will flow between the probe and COM; this flow will be sensed by the electronics which in turn will activate the "HEAT" relay to apply AC power to the HEAT terminal on the control circuit board.

Similarly, the HI probe is located at the desired water level fill (above the LOW probe level) so that when the water level has reached the desired fill level electrical current will flow between the HI probe and COM. The action of this probe is reversed from the previous situation so that when water reaches the HI probe, the WATER fill relay is deactivated so that AC power to the WF is turned off. When the water level drops below the HI probe, the WF terminal will be re-energized after a five second delay. The time delay is to prevent bubbling or turbulence in the generator from chattering to WATER fill relay or the water valve solenoid.

The control runs on 120 vac and is transformer isolated so that the probes and the electronics are run at low voltage and are not common to the AC power line.

Note that in many Cleveland Range generators both sensing probes are inserted from the front top of the unit down into the generator. In this case, the LOW probe will be the longest and the HI probe will be the shortest.

A) SYMPTOMS OF WATER LEVEL CONTROL RELATED PROBLEMS:

- 1) Boiler overfills or floods
- 2) Boiler dry fires (system underfills or doesn't fill)
- 3) Boiler doesn't fill at all
- 4) Water fill solenoid chatter
- 5) Heater contactor chatter
- 6) Fills but cuts out on LOW WATER before filling again
- 7) Overfills but does not heat
- 8) Fills but does not heat

B) POSSIBLE CAUSES:

- 1) Inoperative water level control circuit board (P/N 23198)
- 2) Incorrect or damaged wiring to probes
- 3) Incorrect or damaged wiring from water level board to loads
- 4) Damaged probes
- 5) Probes shorted together
- 6) Scale build-up on probes

C) FAULT ISOLATION PROCEDURE:

Equipment Required: Volt/Ohmmeter (VOM) or Multimeter

<u>STEP</u>	<u>TEST</u>	<u>RESULT</u>	<u>REMEDY</u>
1.	Is power applied to the control circuit board? Measure L1-L2 at the board to be 120 VAC \pm 15V.	Yes	Go to Step #2
		No	Correct external supply problem
2.	Remove two AC power wires from control board and connect ohmmeter to control board power terminals. Is resistance between 100-1000 ohms?	Yes	Reconnect power and go to Step #3
		No	Replace control board P/N 23198 (inoperative transformer)
3.	Visually inspect probe wiring for damaged or broken wires or loose or missing terminals at either end. Is wiring visually OK?	Yes	Go to Step #4
		No	Replace wiring as required

<u>STEP</u>	<u>TEST</u>	<u>RESULT</u>	<u>REMEDY</u>
4.	Are the following connections made correctly?	Yes	Go to Step #5
	A) COM input on board to boiler ground	No	Correct probe wiring as required (see Figure 1)
	B) LO input on board to long length "LO" probe		
	C) HI input on board to short "HI" probe		
5.	Temporarily disconnect the wire from the HTR terminal so that the heat source will not operate. Is the heat source off?	Yes	Go to Step #6
		No	Check heat source and wiring in cooker
6.	With HTR still disconnected, disconnect the LOW wire at the LOW terminal of the control board. Measure the AC line voltage between the HTR and L2 terminals on the control board. Is the voltage 0 vac? NOTE: Digital meters may read a few volts due to their high input impedance; this should be considered as 0 vac.	Yes	Go to Step #7
		No	Replace water level control P/N 23198
7.	Short the LOW and COM terminals on the control board. Does the AC line voltage between the HTR and L2 terminals now read 120 vac (line voltage)?	Yes	Reconnect HTR & LOW wires and go to Step #8
		No	Replace water level control P/N 23198
8.	Disconnect the wires from the HI and COM terminals on the control board and short the HI & COM terminals together. Measure the AC line voltage between the WF and L2 terminals. Is the voltage 0 vac?	Yes	Go to Step #9
		No	Replace water level control P/N 23198

<u>STEP</u>	<u>TEST</u>	<u>RESULT</u>	<u>REMEDY</u>
9.	Remove the short from the HI and COM terminals on the control board. Does the AC line voltage between WF and L2 stay at 0 vac for about five seconds, then jump to 120 vac?	Yes	Reconnect HI & COM wires and go to Step #10
		No	Replace water level control P/N 23198
10.	Drain all water form the generator. Disconnect the wires from the LO, HI, & COM terminals at the control board. Connect an Ohmmeter across the LO and COM wires leading to the generator. Does the Ohmmeter read greater than 100,000 ohms?	Yes	Go to Step #12
		No	Go to Step #11
11.	Disconnect the LO wire at the water sensing probe on the generator. Does the Ohmmeter connected in the previous step now read greater than 100,000 ohms?	Yes	Go to Step #12
		No	Replace probe wiring
12.	Reconnect the ohmmeter across each end of the disconnected LO wire. Does the ohmmeter read less than 10 ohms?	Yes	Go to Step #13
		No	Replace wire
13.	Connect an ohmmeter across the HI and COM wires leading to the generator. Does the ohmmeter read greater than 100,000 ohms?	Yes	Go to Step #15
		No	Go to Step #14
14.	Disconnect the HI wire at the water sensing probe on the generator. Does the ohmmeter connected in the previous step now read greater than 100,000 ohms?	Yes	Replace probe wiring
		No	Go to Step #16
15.	Reconnect the ohmmeter across each end of the disconnected HI wire. Does the ohmmeter read less than 10 ohms?	Yes	Go to Step #16
		No	Replace probe wiring

<u>STEP</u>	<u>TEST</u>	<u>RESULT</u>	<u>REMEDY</u>
16.	Reconnect one lead of the ohmmeter to the COM wire at the control board and connect the other ohmmeter lead to generator ground. Does the ohmmeter read less than 10 ohms?	Yes	Reconnect HI, LOW & COM wires at control board only. Go to Step #17.
		No	Replace probe wiring
17.	Reconnect the ohmmeter across the LOW terminal at the sensing probe & generator ground. Does the ohmmeter read greater than 100,000 ohms?	Yes	Go to Step #18
		No	Replace probe assembly
18.	Reconnect the ohmmeter across the HI terminal at the sensing probe & generator ground. Does the ohmmeter read greater than 100,000 ohms?	Yes	Go to Step #19
		No	Replace probe assembly
19.	Remove probe and check for scale buildup on or across probes. Replace probe assembly as required.		

TG/drl
02898

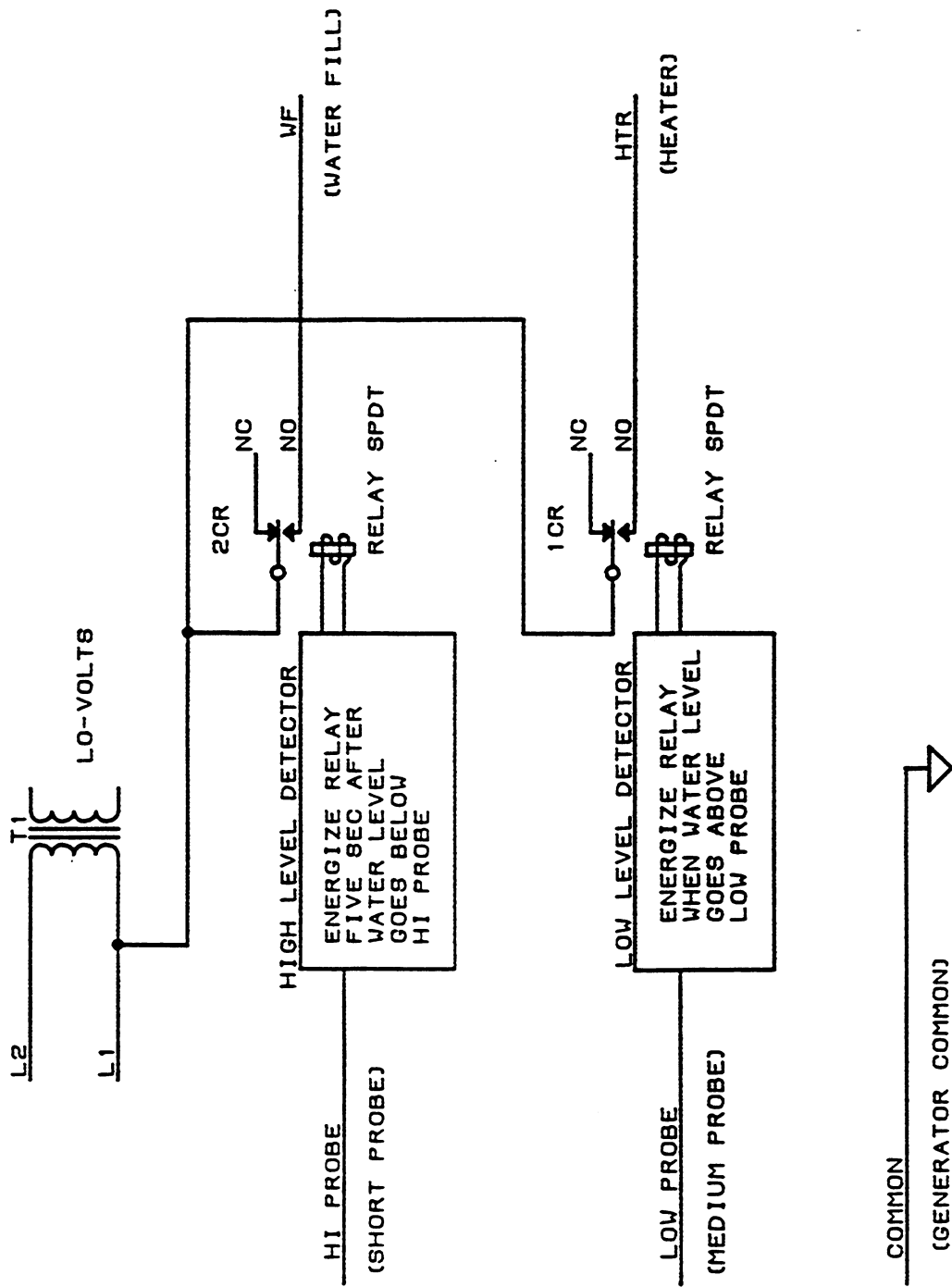

FIGURE 1 TWO-PROBE & COMMON WATER LEVEL CONTROL

