

CONDENSING UNITS FOR HBC75 COOK TANK & HBCC75 COOK CHILL TANK

Project _____
 Item _____
 Quantity _____
 FCSI Section 11400 _____
 Approved _____
 Date _____

Model

- LCH0080MACD
(Air Cooled Condensing Unit)

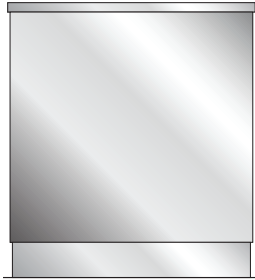

Standard Features

- 8 Hp Air Cooled Compressor
- 87,220 btu/hr at 95° Ambient and +25° FSST
- Designed for efficient operation with R-404A refrigerant
- Liquid line dryer
- Suction line accumulator with heat exchanger
- Crankcase pressure regulating valve
- Suction line filter
- Crankcase Heater
- Suction & Discharge line vibration eliminators
- oil separator
- 67 lb liquid receiver
- 3/60/460V
- Integrated Controls
 - Fixed high and adjustable low pressure controls
 - Sentronic oil failure switch
 - Sight glass
 - Head pressure control
 - Fan cycling

Short Form Specifications

Shall be model LCH0080MACD, 8 Hp Air Cooled Condensing Unit. Rated capacity of 87,220 btu/hr at 95° Ambient and +25° FSST.

Options & Accessories

- 3/60/208-230V Electrical

Model

- LRU1008
(Water Cooled Condensing Unit)

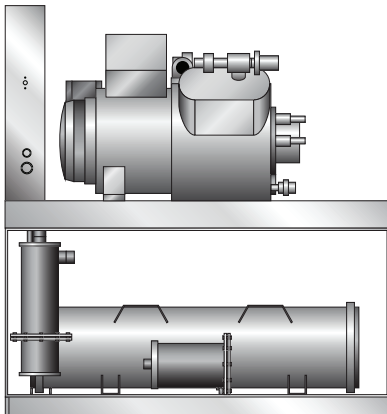

Standard Features

- 8 Hp Water Cooled Compressor
- 97,000 btu/hr at +25° F SST and 85° F EWT (33.3 gpm req'd)
- Designed for efficient operation with R-404A refrigerant
- Liquid line filter/dryer
- Suction line accumulator with heat exchanger
- Crankcase pressure regulating valve
- Water regulating valve
- Suction line filter
- Crankcase Heater
- Suction & Discharge line vibration eliminators
- Coalescent oil separator
- 84 lb liquid receiver
- 3/60/460V
- Integrated Controls
 - Adjustable high and low pressure controls
 - Sentronic oil failure switch
 - Sight glass
 - Head pressure control

Short Form Specifications

Shall be model LRU1008, 8 Hp Water Cooled Condensing Unit. Rated capacity of 97,000 btu/hr at +25° F SST and 85° F EWT

Options & Accessories

- 3/60/208-230V Electrical

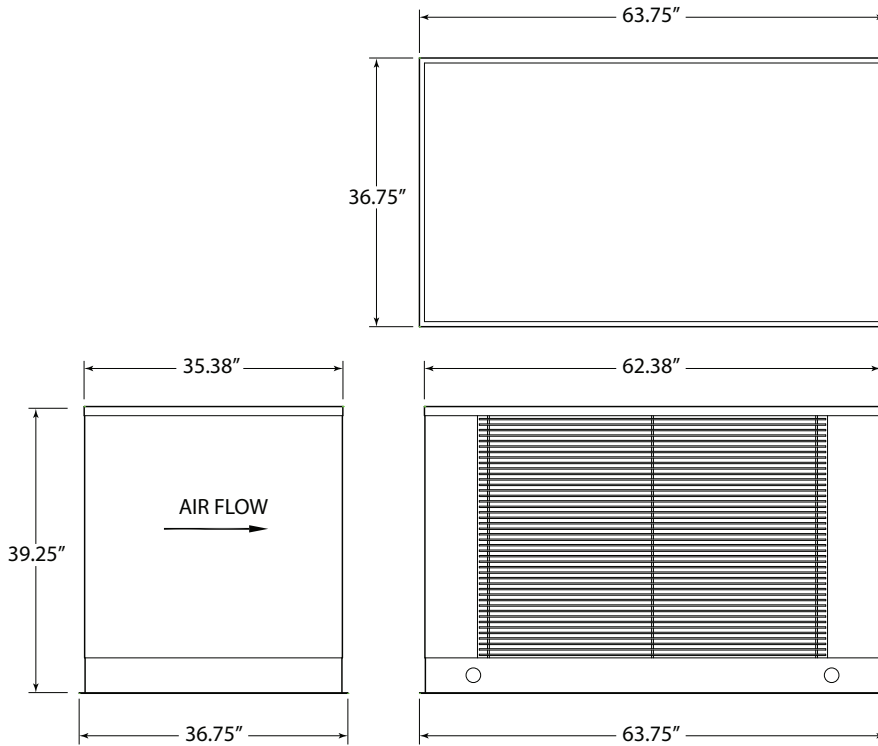

MINIMUM CLEARANCE	
FRONT	36"
REAR	36"

**AIR COOLED
CONDENSING UNIT**

MODEL: LCH0080MACD
 WEIGHT: 1,020 LBS
 DIMENSIONS: 64" L X 37" W X 40" H
 CAPACITY: 87,220 BTU/HR
 @ 25°F SST @ 95°F AMBIENT

ELECTRICAL REQUIREMENTS
 (BASED ON MFG. RECOMMENDED)
 3/60/460V 27 MCA
 3/60/460V 40 MOP
 OR
 3/60/208-230V 52 MCA
 3/60/208-230V 80 MOP

Crate Size: 69"L x 42"W x 50"H
 Crate Weight: 1,350 lbs
 Rate of Class: 85

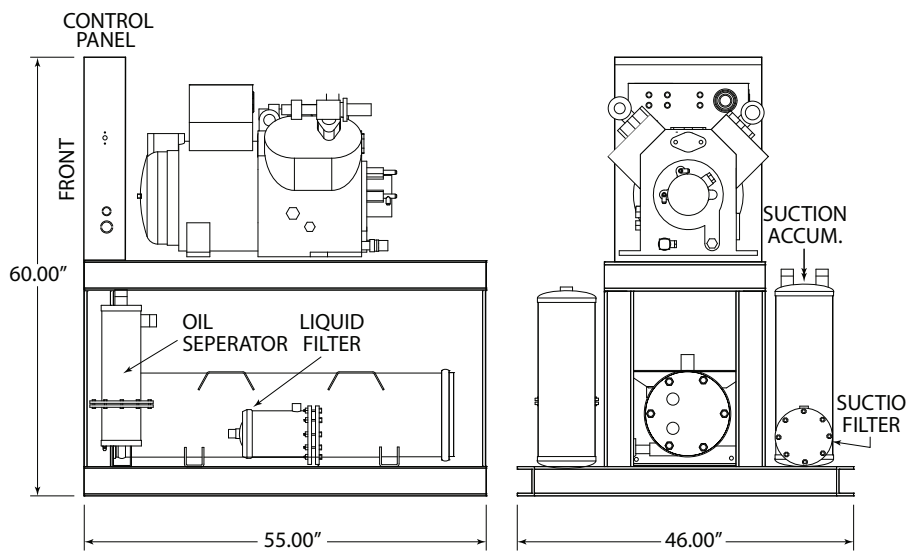

MINIMUM CLEARANCE	
FRONT	36"
ALL OTHER SIDES	24"

**WATER COOLED
CONDENSING UNIT**

MODEL: LRU1008
 WEIGHT: 1,150 LBS
 DIMENSIONS: 55"L X 46"W X 60"H

COOLING WATER: 33 GPM @ 85°F E
 97,000 BTU/HR @ +25°F SST

ELECTRICAL REQUIREMENTS
 (BASED ON MFG. RECOMMENDED)
 3/60/460V 23 MCA
 3/60/460V 40 MOP
 OR
 3/60/208-230V 46 MCA
 3/60/208-230V 80 MOP

Crate Size: 61"L x 52"W x 70"H
 Crate Weight: 1,450 lbs
 Rate of Class: 85

Cleveland Range reserves right of design improvement or modification, as warranted.

(NOT TO SCALE)