

CONDENSING UNITS FOR HBC100 COOK TANK & HBCC100 COOK CHILL TANK

Project _____
 Item _____
 Quantity _____
 FCSI Section 11400 _____
 Approved _____
 Date _____

Model

- LCV0150MACD
(Air Cooled Condensing Unit)

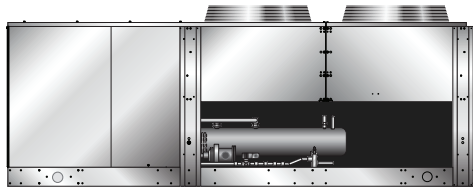

Standard Features

- 15 Hp Air Cooled Compressor
- 141,400 btu/hr at 95° Ambient and +25° FSST
- Designed for efficient operation with R-404A refrigerant
- Liquid line dryer
- Suction line accumulator with heat exchanger
- Crankcase pressure regulating valve
- Suction line filter
- Crankcase Heater
- Suction & Discharge line vibration eliminators
- oil separator
- 123 lb liquid receiver
- 3/60/460V
- Integrated Controls
 - Fixed high and adjustable low pressure controls
 - Sentronic oil failure switch
 - Sight glass
 - Head pressure control
 - Fan cycling

Short Form Specifications

Shall be model LCV0150MACD, 15 Hp Air Cooled Condensing Unit. Rated capacity of 141,400 btu/hr at 95° Ambient and +25° FSST.

Options & Accessories

- 3/60/208-230V Electrical

Model

- LRU1015
(Water Cooled Condensing Unit)

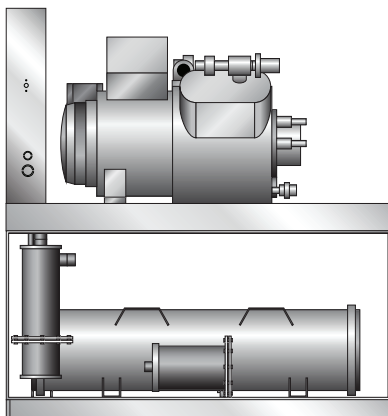

Standard Features

- 15 Hp Water Cooled Compressor
- 158,000 btu/hr at +25° F SST and 85° F EWT (56.7 gpm req'd)
- Designed for efficient operation with R-404A refrigerant
- Liquid line filter/dryer
- Suction line accumulator with heat exchanger
- Crankcase pressure regulating valve
- Water regulating valve
- Suction line filter
- Crankcase Heater
- Suction & Discharge line vibration eliminators
- Coalescent oil separator
- 123 lb liquid receiver
- 3/60/460V
- Integrated Controls
 - Adjustable high and low pressure controls
 - Sentronic oil failure switch
 - Sight glass
 - Head pressure control

Short Form Specifications

Shall be model LRU1050, 15 Hp Water Cooled Condensing Unit. Rated capacity of 158,000 btu/hr at +25° F SST and 85° F EWT

Options & Accessories

- 3/60/208-230V Electrical

MINIMUM CLEARANCE	
FRONT	36"
REAR	36"

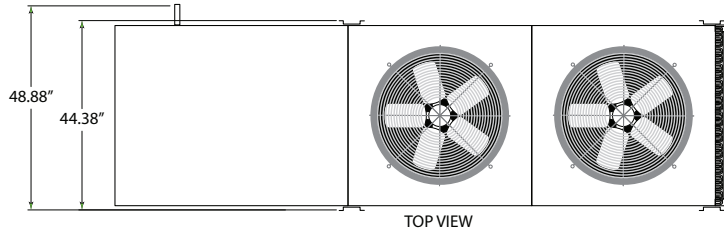

**AIR COOLED
CONDENSING UNIT**

MODEL: LCV0150MACD
 WEIGHT: 1,580 LBS
 DIMENSIONS: 144" L X 45" W X 56" H
 CAPACITY: 141,400 BTU/HR
 @ 25°F SST @ 95°F AMBIENT

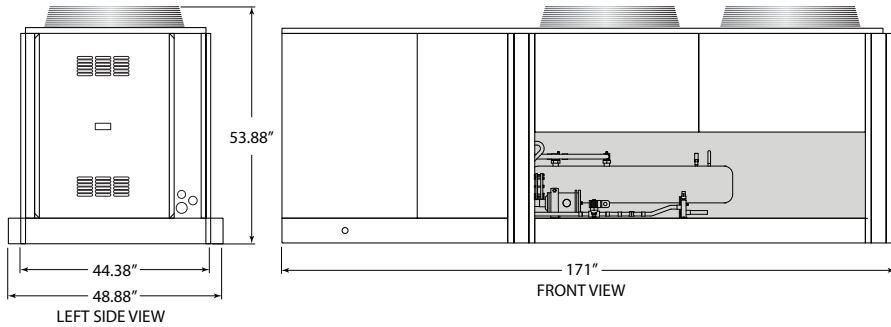

ELECTRICAL REQUIREMENTS
 (BASED ON MFG. RECOMMENDED)
 3/60/460V 37 MCA
 3/60/460V 60 MOP
 OR
 3/60/208-230V 77 MCA
 3/60/208-230V 125 MOP

Crate Size: 69"L x 42"W x 50"H
 Crate Weight: 2,000 lbs
 Rate of Class: 85

MINIMUM CLEARANCE	
FRONT	36"
ALL OTHER SIDES	24"

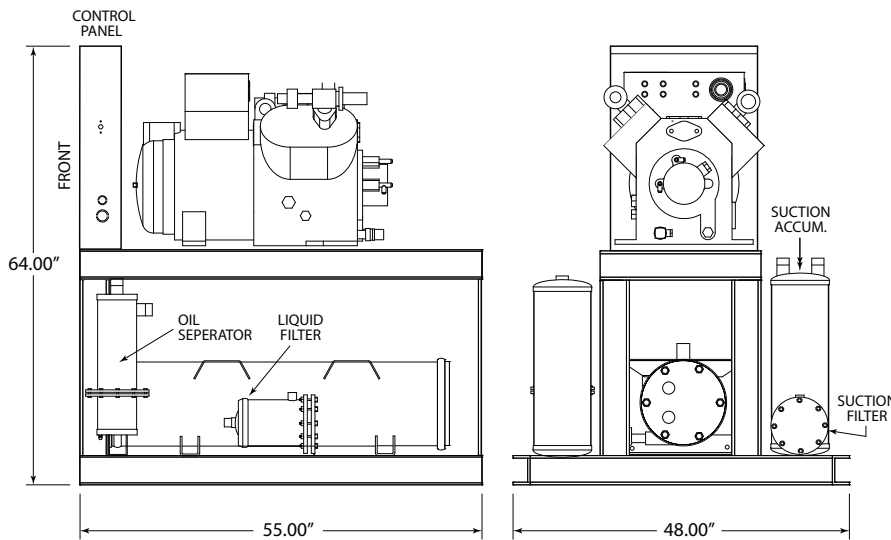

**WATER COOLED
CONDENSING UNIT**

MODEL: LRU1015
 WEIGHT: 1,200 LBS
 DIMENSIONS: 55" L X 48" W X 64" H

COOLING WATER: 56.7 GPM @ 85°F EWT
 158,000 BTU/HR @ +25°F SST

ELECTRICAL REQUIREMENTS
 (BASED ON MFG. RECOMMENDED)
 3/60/460V 34 MCA
 3/60/460V 55 MOP
 OR
 3/60/208-230V 67 MCA
 3/60/208-230V 110 MOP

Crate Size: 61" L x 54" W x 74" H
 Crate Weight: 1,825 lbs
 Rate of Class: 85

Cleveland Range reserves right of design improvement or modification, as warranted.

(NOT TO SCALE)