



AIR COOLED CONDENSING UNITS

Cleveland Standard Features

- Air cooled condensing unit for outdoor installation
- For operation with R-22, 404A or R507 refrigerant (please specify)
- Liquid line filter with replaceable core and sight glass
- High efficiency Copeland discus compressor
- Galvalume weather housing with raised base compressor
- Thermally protected
- Permanently lubricated condenser fan motor(s)
- Access panels for easy servicing of internal components
- Electrical controls are mounted in control box with hinged door
- Receivers include service valves
- Suction and discharge vibration eliminators
- 180 lbs. head pressure valve
- Crankcase heater for cold temperature operation
- Suction filter with replaceable core
- Suction accumulator
- Oil separator
- Low ambient kit
- Anti short cycle timer
- Liquid line solenoid valve (shipped loose)
- Dry contacts for compressor alarm

Options & Accessories

- Water Cooled Condensing Units
- Larger models available upon request
- Extended four (4) year compressor warranty (domestic only)
- Ice Water Control Panel for location in production area
- Ice Builders

- MODELS:** BLH7.5H2 BLH25H2 JLD50H2*
 BLH10H2 BLH30H2 JLD60H2*
 BLH15H2 BLH35H2
 BLH20H2 BLH40H2



**These units have two (2) compressors and are not supplied with fused disconnects*

ITEM NUMBER _____

JOB NAME / NUMBER _____



Short Form Specifications

Shall be CLEVELAND, Model BLH or JLD - _____ - H2, Outdoor, _____ HP, AIR COOLED CONDENSING UNIT for Ice Builder. Weather housing with raised Base Compressor; Receiver with Discharge and Suction Line Vibration eliminators; Pressure Control; Drier/Sight Glass Kit; Liquid Line Solenoid Valve; replaceable Core Suction Line Filter, Suction Line Accumulator; Oil Separator and Oil Failure Safety Control; Head Pressure Control Valve; Control Panel with hinged door housing Low Ambient Kit, Compressor Contactor, and Control Circuit Fusing.

MINIMUM CLEARANCE	
FRONT	24" MIN
SIDE	24" MIN
REAR	24" MIN

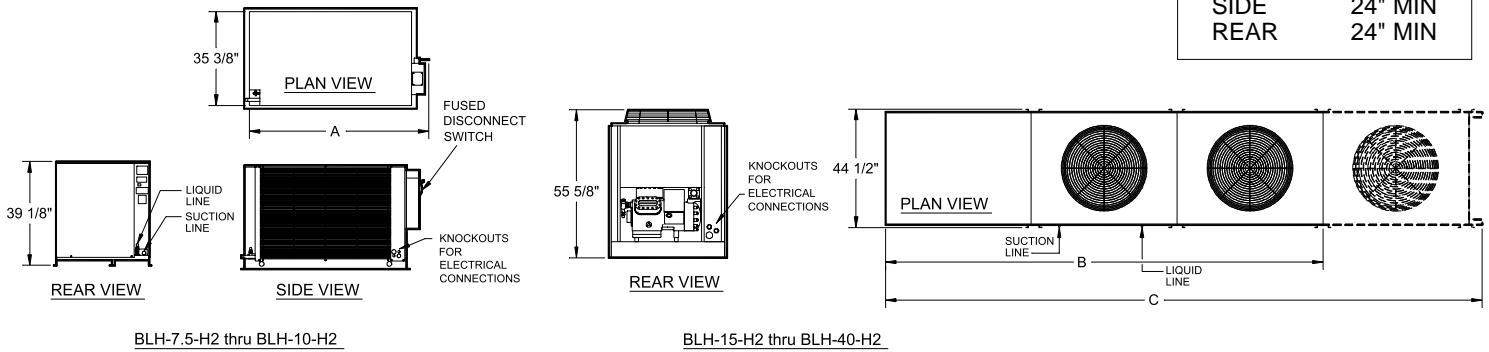

BLH-7.5-H2 thru BLH-10-H2

BLH-15-H2 thru BLH-40-H2

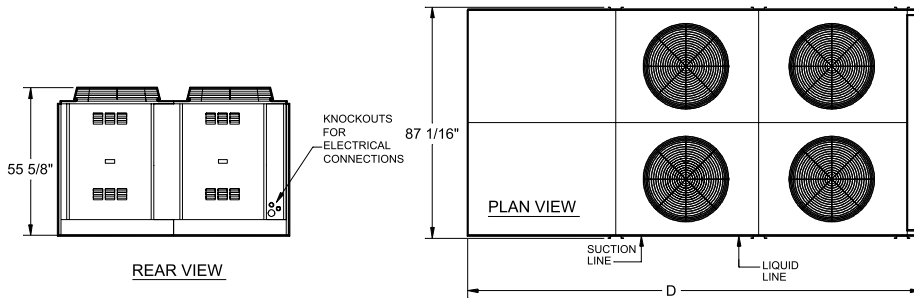

JDL-50-H2 thru JDL-60-H2

DIMENSIONS

MODEL	ICE BUILDER				SHIPPING WEIGHTS	
	MODEL	A	B	C	D	LBS / KG
BLH-7.5-H2	IBC-50	67 3/4"	-	-	-	1350 / 614
BLH-10-H2	IBC-75	67 3/4"	-	-	-	1650 / 750
BLH-15-H2	IBC-100	-	144"	-	-	1900 / 864
BLH-20-H2	IBC-125	-	144"	-	-	1980 / 900
BLH-25-H2	IBC-150	-	170 3/4"	-	-	2170 / 987
BLH-30-H2	IBC-175	-	170 3/4"	-	-	2260 / 1028
BLH-35-H2	IBC-200	-	-	225 3/4"	-	2760 / 1255
BLH-40-H2	IBC-250	-	-	225 3/4"	-	2860 / 1300
JLD-50-H2	IBC-300	-	-	-	171"	4060 / 1846
JLD-60-H2	IBC-350	-	-	-	171"	4520 / 2055

UTILITY CONNECTIONS

MODEL	RECEIVER CAPACITY	LIQUID LINE	SUCTION LINE
	LBS		
BLH-7.5-H2	162	1/2"	1 1/8"
BLH-10-H2	227	7/8"	1 3/8"
BLH-15-H2	275	7/8"	1 5/8"
BLH-20-H2	444	7/8"	1 5/8"
BLH-25-H2	444	1 1/8"	2 1/8"
BLH-30-H2	444	1 1/8"	2 1/8"
BLH-35-H2	672	1 1/8"	2 1/8"
BLH-40-H2	672	1 1/8"	2 1/8"
JLD-50-H2	(2) 444	1 1/8"	2 1/8"
JLD-60-H2	(2) 444	1 1/8"	2 1/8"

ELECTRICAL 208/3PH

COMPRESSOR RATED LOAD AMPS	CONDENSER FAN MOTOR QTY	TOTAL AMP LOAD
28.3	2	38.1
39.1	2	54.3
59.9	2	82.5
66	2	90.5
82.8	2	116.8
94	2	131.5
107	3	154.8
142	3	198.5
*82.2	4	201.0
*94	4	239.5

*PER SIDES

REFRIGERANT NOT SUPPLIED BY CLEVELAND RANGE.
AIR COOLED CONDENSING UNITS ARE FOR OUTDOOR INSTALLATION.



WATER COOLED CONDENSING UNITS

- MODELS:** WS05H2 WS15H2 WS30H2
 WS07H2 WS20H2 WS35H2*
 WS10H2 WS25H2 WS40H2*

**These units are not supplied with fused disconnects*



Cleveland Standard Features

- Water cooled condensing unit for indoor installation
- For operation with R-22, 404A or 507 refrigerant (please specify)
- Liquid line filter with replaceable core and sight glass
- High efficiency Copeland discus compressor
- Spring isolation of compressor
- Shell and tube, cleanable, water cooled condenser with pressure relief valve
- Water regulating valve
- Pre-wired control panel with compressor contactor and control circuit fuse
- Liquid receivers with inlet and outlet valves and pressure relief
- Suction and discharge vibration eliminators
- Crankcase heater for cold temperature operation
- Suction filter with replaceable core
- Suction accumulator
- Oil separator
- Low ambient kit
- Anti short cycle timer
- Liquid solenoid valve (shipped loose)
- Dry contacts for compressor alarm

Options & Accessories

- Air Cooled Condensing Units
- Larger models available upon request
- Extended four (4) year compressor warranty (domestic only)
- Ice Water Control Panel for location in production area
- Ice Builders

ITEM NUMBER _____

JOB NAME / NUMBER _____

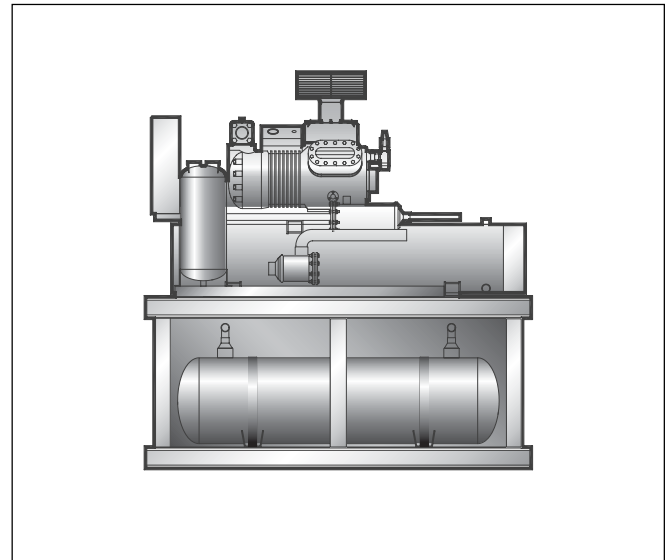

Short Form Specifications

Shall be CLEVELAND Model WS ____ H2, Indoor, ____ HP, WATER COOLED CONDENSING UNIT for Ice Builder. Compressor; Receiver with Discharge and Suction Line Vibration Eliminators; Pressure Control; Drier/Sight Glass Kit; Liquid Line Solenoid Valve; replaceable Core Suction Line Filter, Suction Line Accumulator; Oil Separator and Oil Failure Safety Control; Head Pressure Control Valve; Control Panel with hinged door housing Low Ambient Kit, Compressor Contactor and Control Circuit Fusing; Water Cooled Condenser is cleanable.

MINIMUM CLEARANCE	
FRONT	24"
SIDES	24"
REAR	24"

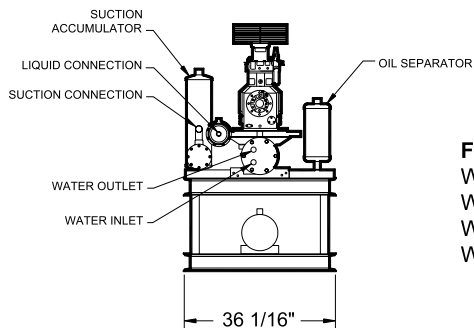
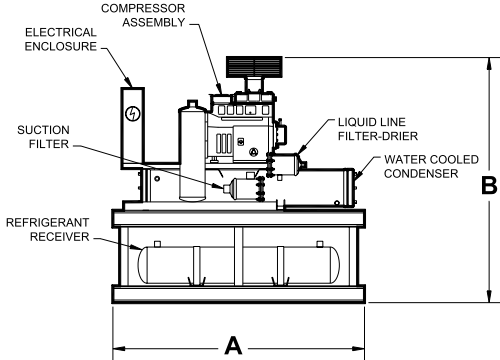

FOR MODELS:
 WS-05-H2
 WS-07-H2
 WS-10-H2
 WS-15-H2

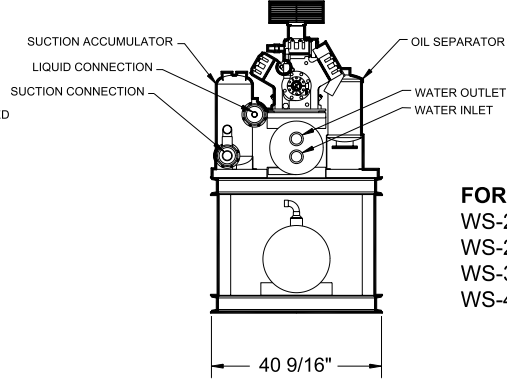
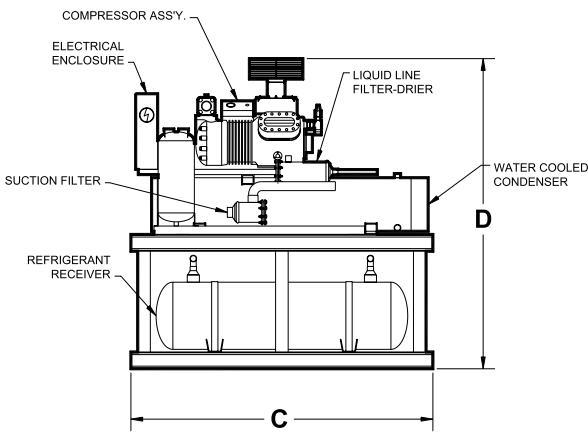

FOR MODELS:
 WS-20-H2
 WS-25-H2
 WS-35-H2
 WS-40-H2

DIMENSIONS

MODEL		A	B	C	D	SHIPPING WEIGHTS
						LBS / KG
WS-05-H2	IBC-25	36"	60 7/8"	-	-	780 \ 355
WS-07-H2	IBC-50	52"	61 3/8"	-	-	780 \ 355
WS-10-H2	IBC-75	60"	58 3/8"	-	-	870 \ 386
WS-15-H2	IBC-100	60"	60 3/8"	-	-	1088 \ 495
WS-20-H2	IBC-125	-	-	75"	69 5/8"	1163 \ 529
WS-25-H2	IBC-150	-	-	72"	71 1/8"	1178 \ 536
WS-30-H2	IBC-175	-	-	72"	70 5/8"	1200 \ 546
WS-35-H2	IBC-200	-	-	72"	73 7/8"	1600 \ 728
WS-40-H2	IBC-250	-	-	72"	76 7/8"	1380 \ 628

UTILITY CONNECTIONS

MODEL	RECEIVER CAPACITY	LIQUID	COLD SUCTION	COMPRESSOR WATER
WS-05-H2	72 lbs	5/8"	1 3/8"	1 1/4"
WS-07-H2	137 lbs	5/8"	1 3/8"	1 1/4"
WS-10-H2	187 lbs	7/8"	1 3/8"	1 1/4"
WS-15-H2	239 lbs	7/8"	1 5/8"	1 1/2"
WS-20-H2	336 lbs	7/8"	1 5/8"	2"
WS-25-H2	385 lbs	1 1/8"	2 1/8"	2 1/2"
WS-30-H2	425 lbs	1 1/8"	2 1/8"	2 1/2"
WS-35-H2	557 lbs	1 1/8"	2 1/8"	2 1/2"
WS-40-H2	602 lbs	1 1/8"	2 1/8"	3"

ELECTRICAL 208/3PH

UNIT	RLA	MOPD
	31.6	60
	31.6	60
	43.6	80
	59.6	110
	66	125
	82.2	150
	94	175
	107	200
	142	250

**REFRIGERANT NOT SUPPLIED BY CLEVELAND RANGE.
 AIR COOLED CONDENSING UNITS ARE FOR OUTDOOR INSTALLATION.**

RLA – RATED LOAD AMPS
 MOPD – MAX OVERCIRCUIT PROTECTION DEVICE

HEATCRAFT®

Refrigeration Products

Refrigeration System Installation

H-IM-64C

August 1996

Part No. 25001201

Replaces H-IM-64B (12/95)

Installation and Maintenance Guide

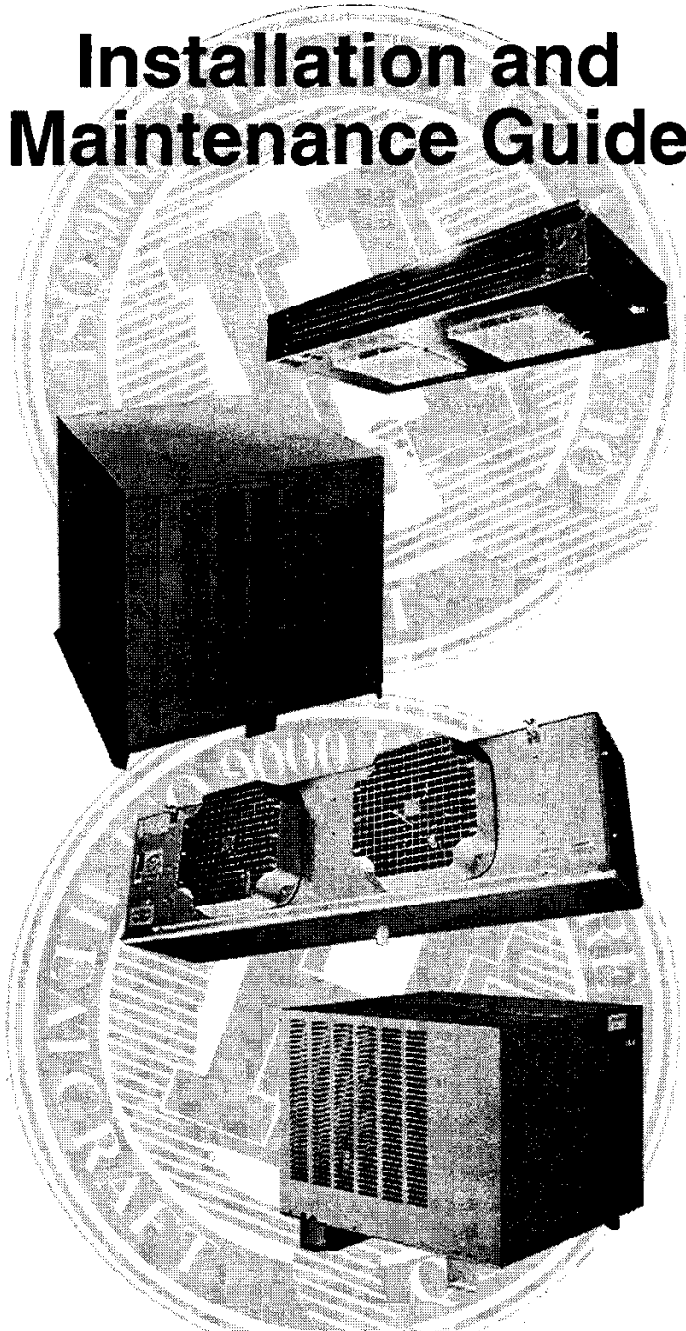

HEATCRAFT INC.

REFRIGERATION PRODUCTS DIVISION

2175 West Park Place Blvd., Stone Mountain, GA 30087

(770) 939-4450 • FAX: (770) 908-5480

Table of Contents

General Safety Information	
Inspection	
Warranty Statement	2
Space and Location Requirements	3
Condensate Drain Lines	
Expansion Valve Selection Charts	4-5
Expansion Valves & Distributor Nozzles	6-7
Unit Coolers	
Rigging & Mounting	
Placement	8-9
Spring Mounts	
Copeland Demand Cooling for L2 Models	
Demand Cooling System Design	10-11
Line Sizing	
Pressure Loss of Liquid Refrigerants in Liquid Line Risers	
Equivalent Feet of Pipe Due to Valve and Fitting Friction	11
Weight of Refrigerants in Copper Lines During Operation	12
Recommended Remote Condenser Line Sizes	13
Recommended Line Sizes for R-134a	14-15
Recommended Line Sizes for R-22	16-17
Recommended Line Sizes for R-502	18-19
Recommended Line Sizes for R-404A and R507	20-21
Refrigerant Piping	22
Suction Lines	
Liquid Lines	23
Evacuation and Leak Detecting	24
Refrigerant Charging Instructions	
Field Wiring	
Check-Out and Start-Up	25
Operational Check-Out	
System Balancing - Compressor Superheat	
Phase Loss Monitor	26
Evaporator Superheat	
Defrost	
Defrost Thermostat	27
Sequence of Operation	
Head Pressure Control	28
Valve Piping Arrangements	
Ambient Fan Cycle Control	29
Suction Filters, Driers, Sight Glasses	
Recommended Low Pressure Control Settings	
Thermostat Settings	30
Refrigerant Oils	
Polyol Ester Lubricants	31
System Troubleshooting Chart	32
Maintenance	
Evaporator Troubleshooting Chart	33
Typical Wiring Diagrams	34-38
Notes	39
Service Record	40

General Safety Information

1. Installation and maintenance to be performed only by qualified personnel who are familiar with this type of equipment.
2. Make sure that all field wiring conforms to the requirements of the equipment and all applicable national and local codes.
3. Avoid contact with sharp edges and coil surfaces. They are a potential injury hazard.
4. Make sure all power sources are disconnected before any service work is done on units.

Inspection

Responsibility should be assigned to a dependable individual at the job site to receive material. Each shipment should be carefully checked against the bill of lading. The shipping receipt should not be signed until all items listed on the bill of lading have been accounted for. Check carefully for concealed damage. Any shortage or damages should be reported to the delivering

carrier. Damaged material becomes the delivering carrier's responsibility, and should not be returned to the manufacturer unless prior approval is given to do so. When uncrating, care should be taken to prevent damage. Heavy equipment should be left on its shipping base until it has been moved to the final location.

Warranty Statement

Heatcraft warrants to its direct purchasers that products, except Service Parts, manufactured by Heatcraft shall be of a merchantable quality, free of defects in material or workmanship, under normal use and service for a period of one (1) year from date of original installation, or eighteen (18) months from date of shipment by Heatcraft, whichever first occurs. Service Parts, for product out of original warranty, should be so warranted for a period of ninety (90) days from date of installation, or twelve (12) months from date of shipment whichever may first occur. Any product covered by this order found to Heatcraft's satisfaction to be defective upon examination at Heatcraft's factory will, at Heatcraft's option, be repaired or replaced and returned to Buyer via lowest common carrier, or Heatcraft may at its option grant Buyer a credit for the purchase price of the defective article. Upon return of a defective product to Heatcraft's plant, freight prepaid, by Buyer, correction of such defect by repair or replacement, and return freight via lowest common carrier, shall constitute full performance by Heatcraft of its obligations hereunder.

Hermetic compressors furnished by Heatcraft are subject to the standard warranty terms set forth above, except that motor compressor replacements or exchanges shall be made through the nearest authorized wholesaler of the motor compressor manufacturer (not at Heatcraft's factory) and no freight shall be allowed for transportation of the motor compressor to and from the wholesaler. The replacement motor compressor shall be identical to the model of the motor compressor being replaced. Additional charges which may be incurred throughout the substitution of other than identical replacements are not covered by this warranty.

The foregoing is in lieu of all other warranties, express or implied, notwithstanding the provisions of the uniform commercial code, the Magnuson-Moss Warranty-Federal Trade Commission Improvement Act, or any other statutory or common law, federal or state.

Heatcraft makes no warranty expressed or implied, of fitness for any particular purpose, or of any other nature whatsoever, with respect to products manufactured or sold by Heatcraft hereunder, except as specifically set forth above and on the face hereof. It is expressly understood and agreed that Heatcraft shall not be liable to buyer, or any customer of Buyer, for direct or indirect, special, incidental, consequential or penal damages, or for any expenses incurred by reason of the use or misuse by Buyer or third parties of said products. To the extent said products may be considered "Consumer Products," as defined in Section 101 of the Magnuson-Moss warranty-Federal Trade Commission Improvement Act, Heatcraft makes no warranty of any kind,

express or implied, to "Consumers," except as specifically set forth above and on the face hereof.

This equipment is designed to operate properly and produce the rated capacity when installed in accordance with good refrigeration practice.

The following conditions should be adhered to when installing this unit to maintain the manufacturers warranty:

- (a) System piping must be in accordance with good refrigeration practices.
- (b) **Inert gas must be charged into the piping during brazing.**
- (c) The power supply to the unit must meet the following conditions:
 - A. Three phase voltages must be +/- 10% of nameplate ratings. Single phase must be within +10% or -5% of nameplate ratings.
 - B. Phase imbalance cannot exceed 2%.
- (d) All control and safety switch circuits must be properly connected according to the wiring diagram.
- (e) The factory installed wiring must not be changed without written factory approval.

Four-Year Extended Warranty

The Equipment Dealer may purchase for the Owner at the time of the original invoice of the equipment a Four-Year Limited Replacement Compressor Warranty. This entitles the owner to be reimbursed for the cost of a replacement compressor, less salvage credit, during the second through fifth year of the life of the compressor.

The warranty program functions similarly to the standard warranty offered. When a compressor failure occurs and the unit is exchanged "over the counter" at the authorized wholesaler outlet a salvage credit is issued along with the invoice for the new compressor. Return copies of both the credit and invoice to the Equipment Dealer along with the model and serial number of the condensing unit. The Equipment Dealer will process this claim with the Manufacturer and subsequently reimburse the Owner for the cost of the new compressor.

This warranty covers the actual compressor only and does not extend to any labor, trip charges, crane rental, taxes or additional parts, refrigerant or processing/handling charges required to make the unit operational.

Space and Location Requirements

The most important consideration which must be taken into account when deciding upon the location of air-cooled equipment is the provision for a supply of ambient air to the condenser, and removal of heated air from the condensing unit or remote condenser area. Where this essential requirement is not adhered to, it will result in higher head pressures, which cause poor operation and potential failure of equipment. Units must not be located in the vicinity of steam, hot air or fume exhausts. Corrosive atmospheres require custom designed condensers.

Another consideration which must be taken is that the unit should be mounted away from noise sensitive spaces and must have adequate support to avoid vibration and noise transmission into the building. Units should be mounted over corridors, utility areas, rest rooms and other auxiliary areas where high levels of sound are not an important factor. Sound and structural consultants should be retained for recommendations.

Figure 1. Space and Location Requirements for Condensing Units and Remote Condensers

Walls or Obstructions

The unit should be located so that air may circulate freely and not be recirculated. For proper air flow and access all sides of the unit should be a minimum of "W" away from any wall or obstruction. It is preferred that this distance be increased whenever possible. Care should be taken to see that ample room is left for maintenance work through access doors and panels. Overhead obstructions are not permitted. When the unit is in an area where it is enclosed by three walls the unit must be installed as indicated for units in a pit.

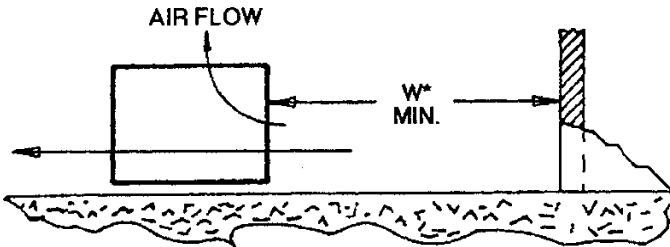

Multiple Units

For units placed side by side, the minimum distance between units is the width of the largest unit. If units are placed end to end, the minimum distance between units is 4 feet.

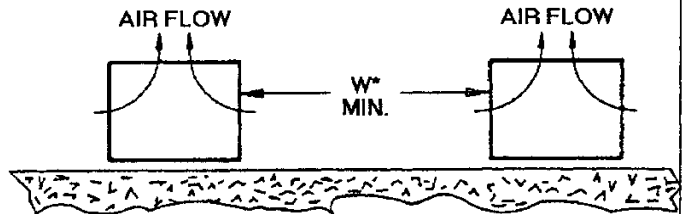

Units in Pits

The top of the unit should be level with the top of the pit, and side distance increased to "2W".

If the top of the unit is not level with the top of pit, discharge cones or stacks must be used to raise discharge air to the top of the pit. This is a minimum requirement.

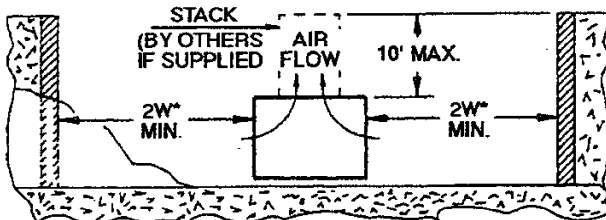

Decorative Fences

Fences must have 50% free area, with 1 foot undercut, a "W" minimum clearance, and must not exceed the top of unit. If these requirements are not met, unit must be installed as indicated for "Units in pits".

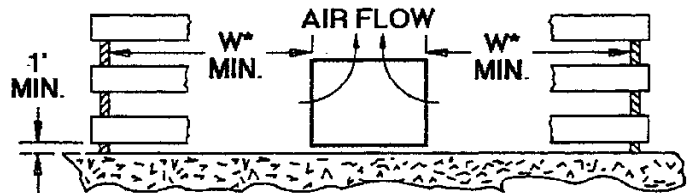

Walls or Obstructions for Horizontal Air Flow

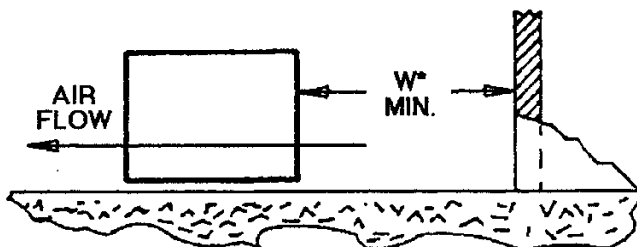

Multiple Units with Horizontal Air Flow

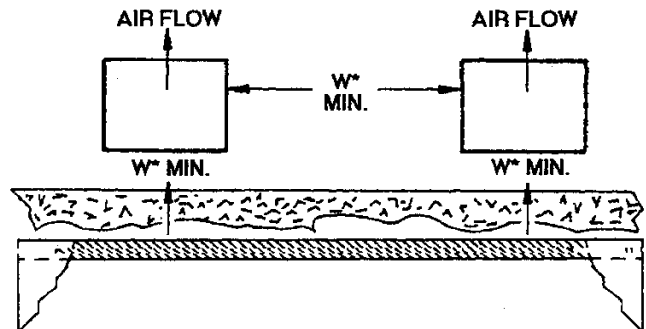

* "W" = Total width of the condensing unit or condenser.

Condensate Drain Lines

Either copper or steel drain lines should be used and properly protected from freezing. In running drain lines, provide a minimum 4 inches per foot pitch for proper drainage. All plumbing connections should be made in accordance with local plumbing codes. All condensate drain lines must be trapped, and run to an open drain. They must never be connected directly to the sewer system. Traps in the drain line must be located in a warm ambient. We recommend a trap on all evaporators. Traps located outside, or extensive outside runs of drain line must be wrapped with a drain line heater. The heater should be connected so that it is continuously on. It is recommended that the drain line be insulated to prevent heat loss. A heat input of 20 watts per lineal foot of drain line for 0°F (-18°C) room applications and 30 watts per lineal foot for -20°F (-29°C) rooms is satisfactory.

Inspect drain pan periodically to insure free drainage of condensate. If drain pan contains standing water, check for proper installation. The drain pan should be cleaned regularly with warm soapy water.

WARNING: All power must be disconnected before cleaning. Drain pan also serves as cover of hazardous moving parts. Operation of unit without drain pan constitutes a hazard.

Figure 2. Condensate Drain Lines

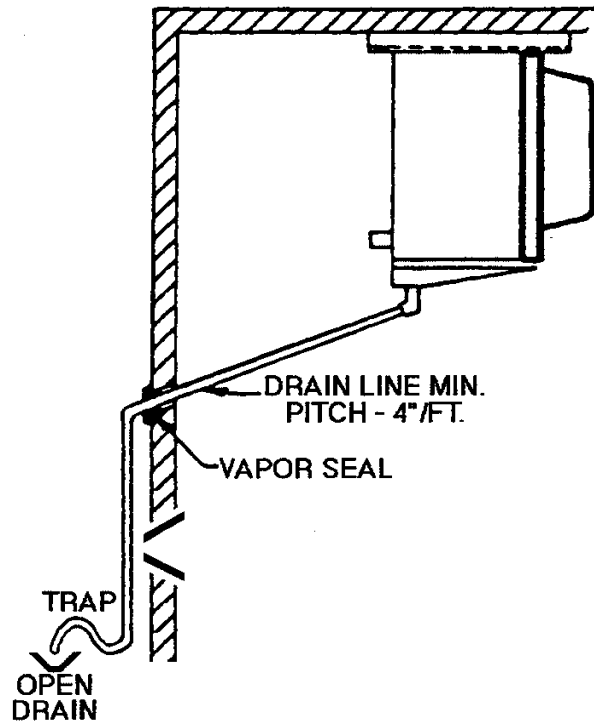

Table 1. Expansion Valve Selection For 100# Head Pressure Valve

BTUH at about 10° T.D.	R-502/R-507/R404A		R-502/R-507/R404A		R-22		R-22	
	-20°F/-29°C Evap.		+25°F/-4°C Evap.		-20°F/-29°C Evap.		+25°F/-4°C Evap.	
	Sporlan	ALCO	Sporlan	ALCO	Sporlan	ALCO	Sporlan	ALCO
3,000-5,000	FRE 1/2 ZP	HFESC 1/2 RWZ	FRE 1/2 C	HFESC 1/2 RW	FVE 1/2 Z	HFESC 1/2 HWZ	FVE 1/2 C	HFESC 1/2 HW
5,500-7,000	FRE 1/2 ZP	HFESC 1/2 RWZ	FRE 1 C	HFESC 1 RW	FVE 1 ZP	HFESC 1 HWZ	FVE 1 C	HFESC 1 HW
7,500-8,000	FRE 1 ZP	HFESC 1 RWZ	FRE 1 C	HFESC 1 RW	FVE 1 ZP	HFESC 1 HWZ	FVE 1 C	HFESC 1 HW
8,500-10,000	FRE 1 ZP	HFESC 1 RWZ	FRE 1 1/2 C	HFESC 1 1/2 RW	FVE 1 1/2 ZP	HFESC 1 1/2 HWZ	FVE 1 C	HFESC 1 HW
10,500-11,000	FRE 1 ZP	HFESC 1 RWZ	FRE 1 1/2 C	HFESC 1 1/2 RW	FVE 1 1/2 ZP	HFESC 1 1/2 HWZ	FVE 1 1/2 C	HFESC 1 1/2 HW
11,500-13,000	FRE 1 1/2 ZP	HFESC 1 1/2 RWZ	FRE 1 1/2 C	HFESC 1 1/2 RW	FVE 1 1/2 ZP	HFESC 1 1/2 HWZ	FVE 1 1/2 C	HFESC 1 1/2 HW
13,500-15,000	FRE 1 1/2 ZP	HFESC 1 1/2 RWZ	FRE 2 C	HFESC 2 RW	FVE 2 ZP	HFESC 2 HWZ	FVE 1 1/2 C	HFESC 1 1/2 HW
15,500-17,000	FRE 2 ZP	HFESC 2 RWZ	FRE 2 C	HFESC 2 RW	FVE 2 ZP	HFESC 2 HWZ	FVE 2 C	HFESC 2 HW
17,500-20,000	FRE 2 ZP	HFESC 2 RWZ	SRE 3 C	HFESC 3 RW	FVE 3 ZP	HFESC 3 HWZ	FVE 2 C	HFESC 2 HW
20,500-24,000	SRE 3 ZP	HFESC 2 RWZ	SRE 3 C	HFESC 3 RW	SVE 3 ZP	TCLE 3 HWZ	SVE 3 C	HFESC 3 HW
24,500-28,000	SRE 3 ZP	HFESC 3 RWZ	SRE 4 C	HFESC 3 RW	SVE 4 ZP	TCLE 5 HWZ	SVE 3 C	HFESC 3 HW
28,500-34,000	SRE 4 ZP	HFESC 3 RWZ	SRE 4 C	TCLE 4 1/2 RW	SVE 5 ZP	TCLE 7 1/2 HWZ	SVE 4 C	TCLE 3 HW
34,500-40,000	ORE 6 ZP	TCLE 4 1/2 RWZ	ORE 6 C	TCLE 4 1/2 RW	SVE 8 ZP	TCLE 7 1/2 HWZ	SVE 4 C	TCLE 5 HW
40,500-50,000	ORE 8 ZP	TCLE 4 1/2 RWZ	ORE 8 C	TCLE 7 RW	SVE 10 ZP	TCLE 10 HWZ	SVE 5 C	TCLE 7 1/2 HW
50,500-60,000	ORE 9 ZP	TCLE 7 1/2 RWZ	ORE 9 C	TCLE 8 RW	SVE 10 ZP	TCLE 10 HWZ	SVE 8 C	TCLE 7 1/2 HW
60,500-70,000	ORE 9 ZP	TCLE 7 1/2 RWZ	ORE 9 C	TCLE 8 RW	OVE 15 ZP	TCLE 10 HWZ	SVE 8 C	TCLE 7 1/2 HW
70,500-80,000	ORE 12 ZP	TCLE 8 RWZ	ORE 12 C	TCLE 8 RW	OVE 15 ZP	TCLE 10 HWZ	OVE 10 C	TCLE 10 HW
80,500-90,000	ORE 12 ZP	TCLE 8 RWZ	ORE 12 C	TJRE 12 RW	OVE 15 ZP	TCLE 10 HWZ	OVE 10 C	TCLE 10 HW
90,500-100,000	ORE 12 ZP	TCLE 8 RWZ	ORE 12 C	TJRE 12 RW	OVE 15 ZP	TCLE 10 HWZ	OVE 15 C	TCLE 12 HW
100,500-110,000	ORE 21 ZP	TJRE 12 RWZ	ORE 21 C	TJRE 16 RW	OVE 20 ZP	TJRE 14 HWZ	OVE 15 C	TCLE 12 HW
110,500-120,000	ORE 21 ZP	TJRE 12 RWZ	ORE 21 C	TJRE 16 RW	OVE 20 ZP	TJRE 18 HWZ	OVE 15 C	TJRE 14 HW
120,500-130,000	ORE 21 ZP	TJRE 12 RWZ	ORE 21 C	TJRE 16 RW	OVE 20 ZP	TJRE 18 HWZ	OVE 15 C	TJRE 14 HW

Table 2. Expansion Valve Selection 180# Head Pressure Valve

BTUH at about 10° T.D.	R-502/R-507/R404A		R-502/R-507/R404A		R-22		R-22	
	-20°F/-29°C Evap.		+25°F/-4°C Evap.		-20°F/-29°C Evap.		+25°F/-4°C Evap.	
	Sporlan	ALCO	Sporlan	ALCO	Sporlan	ALCO	Sporlan	ALCO
3,000-5,000	FRE 1/2 ZP	HFESC 1/2 RWZ	FRE 1/2 C	HFESC 1/2 RW	FVE 1/2 ZP	HFESC 1/2 HWZ	FVE 1/2 C	HFESC 1/2 HW
5,500-7,000	FRE 1/2 ZP	HFESC 1/2 RWZ	FRE 1 C	HFESC 1 RW	FVE 1 ZP	HFESC 1 HWZ	FVE 1/2 C	HFESC 1 HW
7,500-8,000	FRE 1 ZP	HFESC 1 RWZ	FRE 1 C	HFESC 1 RW	FVE 1 ZP	HFESC 1 HWZ	FVE 1 C	HFESC 1 HW
8,500-10,000	FRE 1 ZP	HFESC 1 RWZ	FRE 1 C	HFESC 1 RW	FVE 1 1/2 ZP	HFESC 1 1/2 HWZ	FVE 1 C	HFESC 1 HW
10,500-11,000	FRE 1 ZP	HFESC 1 RWZ	FRE 1 1/2 C	HFESC 1 1/2 RW	FVE 1 1/2 ZP	HFESC 1 1/2 HWZ	FVE 1 C	HFESC 1 HW
11,500-13,000	FRE 1 1/2 ZP	HFESC 1 1/2 RWZ	FRE 1 1/2 C	HFESC 1 1/2 RW	FVE 1 1/2 ZP	HFESC 2 HWZ	FVE 1 C	HFESC 1 1/2 HW
13,500-15,000	FRE 2 ZP	HFESC 2 RWZ	FRE 1 1/2 C	HFESC 1 1/2 RW	FVE 2 ZP	HFESC 2 HWZ	FVE 1 1/2 C	HFESC 1 1/2 HW
15,500-17,000	FRE 2 ZP	HFESC 2 RWZ	FRE 2 C	HFESC 2 RW	FVE 2 ZP	HFESC 3 HWZ	FVE 1 1/2 C	HFESC 1 1/2 HW
17,500-20,000	FRE 2 ZP	HFESC 2 RWZ	FRE 2 C	HFESC 2 RW	FVE 3 ZP	HFESC 3 HWZ	FVE 1 1/2 C	HFESC 2 HW
20,500-24,000	SRE 3 ZP	TCLE 3 RWZ	SRE 3 C	TCLE 3 RW	SVE 3 ZP	TCLE 3 HWZ	SVE 2 C	TCLE 2 HW
24,500-28,000	SRE 4 ZP	TCLE 3 RWZ	SRE 3 C	TCLE 3 RW	SVE 4 ZP	TCLE 3 HWZ	SVE 3 C	TCLE 3 HW
28,500-34,000	SRE 4 ZP	TCLE 3 RWZ	SRE 4 C	TCLE 3 RW	SVE 4 ZP	TCLE 5 HWZ	SVE 3 C	TCLE 3 HW
34,500-40,000	SRE 6 ZP	TCLE 4 1/2 RWZ	SRE 6 C	TCLE 4 1/2 RW	SVE 5 ZP	TCLE 5 HWZ	SVE 3 C	TCLE 3 HW
40,500-50,000	ORE 9 ZP	TCLE 4 1/2 RWZ	SRE 6 C	TCLE 4 1/2 RW	SVE 8 ZP	TCLE 7 1/2 HWZ	SVE 4 C	TCLE 5 HW
50,500-60,000	ORE 9 ZP	TCLE 7 RWZ	ORE 9 C	TCLE 7 RW	SVE 10 ZP	TCLE 7 1/2 HWZ	SVE 5 C	TCLE 5 HW
60,500-70,000	ORE 9 ZP	TCLE 7 RWZ	ORE 9 C	TCLE 8 RW	OVE 15 ZP	TCLE 10 HWZ	SVE 5 C	TCLE 7 1/2 HW
70,500-80,000	ORE 12 ZP	TCLE 8 RWZ	ORE 12 C	TCLE 8 RW	OVE 15 ZP	TCLE 10 HWZ	SVE 8 C	TCLE 7 1/2 HW
80,500-90,000	ORE 12 ZP	TCLE 8 RWZ	ORE 12 C	TCLE 8 RW	OVE 15 ZP	TCLE 10 HWZ	SVE 8 C	TCLE 7 1/2 HW
90,500-100,000	ORE 12 ZP	TCLE 8 RWZ	ORE 12 C	TJRE 12 RW	OVE 15 ZP	TCLE 10 HWZ	OVE 10 C	TCLE 10 HW
100,500-120,000	ORE 12 ZP	TJRE 12 RWZ	ORE 12 C	TJRE 12 RW	OVE 20 ZP	TJRE 14 HWZ	OVE 10 C	TCLE 10 HW
120,500-130,000	ORE 21 ZP	TJRE 12 RWZ	ORE 12 C	TJRE 12 RW	OVE 20 ZP	TJRE 14 HWZ	OVE 15 C	TCLE 12 HW

Figure 3. Bulb and Contact Location

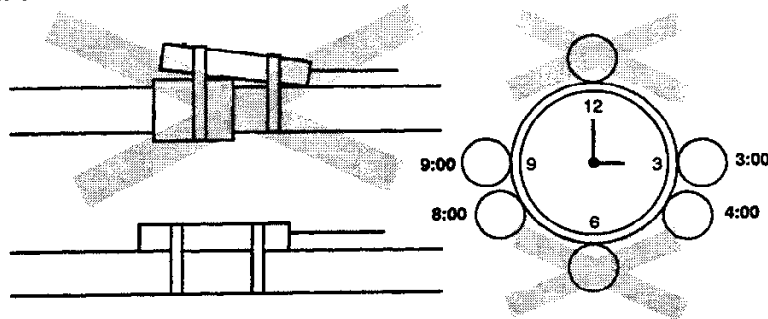
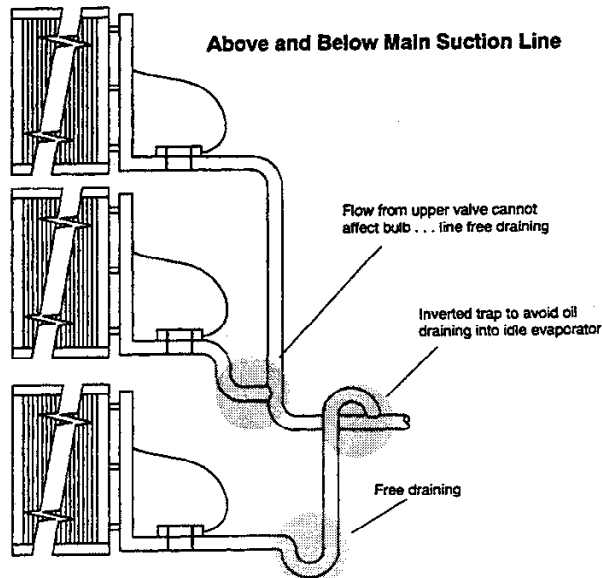

Figure 4. Multiple Evaporators



Distributor Nozzles

Nozzles supplied with unit coolers are selected for numerous refrigerants at cataloged operating conditions and 80°F liquid entering the expansion valve. If mechanical or another method of subcooling is used, the nozzle and expansion valve selection should be checked. For conditions outside those cataloged, use the charts to select a proper nozzle. Nozzle capacity should be

within 110% to 180% of unit operating condition for optimum coil performance. Nozzles are available from Sporlan Wholesalers or from Heatcraft Refrigeration Products. A small nozzle can be drilled larger using the I.D. column. The hole must be accurately centered in the nozzle. A lathe is preferred for accurate drilling.

Expansion Valves and Distributor Nozzles

Before installing the expansion valve on the distributor of the evaporator, the proper distributor nozzle must be installed. Two nozzles are normally shipped with each evaporator for different refrigerants. Select the nozzle for the refrigerant that will be used. The size of the nozzles shipped with each evaporator is based on ordinary conditions, usually 80°F liquid temperatures and a maximum of 15°F evaporator TD's. If a mechanical subcooler is to be used in your system, consult the factory or a representative for distributor nozzle sizing. This is very important as the nominal capacity of the nozzle increases as the liquid refrigerant temperature is lowered. If the correct size nozzle is not installed, poor refrigerant distribution may occur and poor evaporator operation may be experienced.

For peak performance, it is important to select an expansion valve with the correct capacity and selective charge. Thermostatic expansion valves may be mounted in any position, but they should be installed as close to the evaporator as possible. For best performance, the outlet of the expansion valve should be installed directly to the distributor body. If this

is not possible, the distance between the valve outlet and distributor should not exceed 24 inches and not contain any ells or bends or refrigerant distribution problems may occur. The tube connecting the valve outlet and distributor can be sized smaller to maintain refrigerant velocities and better distribution. Elbows located between the expansion valve and distributor will hinder proper distribution and therefore, are not recommended. Some accessories may, however, necessitate the use of elbows.

Locate the expansion valve bulb on a horizontal length of suction line as close to the suction header as possible. The bulb should be clamped tightly on the suction line and insulated with a waterproof type of insulation. The bulb should never be placed on a coupling or other obstruction so as to not make 100 % contact with the suction line. The bulb should never be placed in a trap or downstream of a trap in a suction line. Locating the bulb on the bottom of a suction line is not recommended. The bulb should be installed at the 3, 4 or 8, 9 o'clock position on the suction line. See Figure 3 on page 5.

Selecting Distributor Nozzle at the Jobsite

You must know 4 things:

1. Refrigerant
2. Evaporating Temperature
3. Tons or BTUH
4. Highest Liquid Temperature

EXAMPLE: Select a nozzle for R22, 20°F suction; 67,000 BTUH, 100°F liquid entering TXV.

$$\frac{67,000}{12,000} = 5.58 \text{ Tons}$$

From Table 3 on page 7 select Size 5 rated at 4.80 tons. We prefer selecting at 100% + of nominal rating. We therefore selected the smaller size nozzle.

$$\frac{5.58}{4.80} = 116\% \text{ of Nominal Rating - okay.}$$

EXAMPLE: Select a nozzle for R404A, -20°F suction; 9,400 BTUH, 60°F liquid entering TXV.

$$\frac{9,400}{12,000} = .78 \text{ Tons} \quad [1.98 \text{ Factor for } 60^\circ\text{F Liquid}]$$

$$\frac{0.78}{1.98} = .39 \text{ Corrected Tons}$$

From Table 3 on page 7 select Size 1 rated at 0.35 tons.

$$\frac{0.39}{0.35} = 111\% \text{ of Nominal Rating - okay.}$$

Typical selections would be between 110% and 180%.

Worksheet:

Given Values

Refrigerant _____

Suction Temperature _____ °F

BTUH _____

Liquid Temperature _____ °F

Calculations: _____ BTUH ÷ 12,000 = _____ Tons

Liquid Correction Factor:

_____ °F liquid = _____ Factor

_____ Tons ÷ _____ Factor = _____ Corrected Tons

Nozzle Selections (Table 3)

_____ Tons ÷ _____ Nozzle Capacity = _____ %

(If within 110% to 180%, it is acceptable)

Table 3. Distributor Nozzle Capacities in Tons of Refrigeration

Nozzle Orifice		Refrigerant & Evaporating Temperature °F											
		R22					R507, R502, HP80, R404A				R134a, R12, MP39		
No.	I.D.	40°	20°	0°	-20°	-40°	20°	0°	-20°	-40°	40°	20°	0°
1/4	0.052	0.33	0.26	0.21	0.18	0.15	0.17	0.13	0.11	0.09	0.18	0.14	0.11
1/3	0.060	0.44	0.34	0.28	0.23	0.20	0.23	0.17	0.14	0.12	0.24	0.18	0.14
1/2	0.070	0.61	0.48	0.37	0.28	0.25	0.31	0.22	0.17	0.13	0.35	0.28	0.22
3/4	0.086	0.91	0.74	0.60	0.48	0.35	0.46	0.38	0.29	0.19	0.53	0.44	0.34
1	0.099	1.20	0.96	0.78	0.62	0.50	0.67	0.49	0.35	0.26	0.71	0.56	0.47
1.5	0.120	1.80	1.50	1.20	0.90	0.75	0.93	0.71	0.52	0.39	1.00	0.80	0.69
2	0.140	2.40	2.00	1.60	1.20	1.00	1.30	0.98	0.75	0.58	1.40	1.10	0.95
2.5	0.157	3.00	2.40	1.90	1.50	1.20	1.60	1.20	0.93	0.71	1.80	1.40	1.15
3	0.172	3.60	3.00	2.30	1.80	1.50	2.00	1.40	1.10	0.84	2.20	1.70	1.40
4	0.199	4.90	4.00	3.10	2.50	2.00	2.60	2.00	1.50	1.20	2.80	2.20	1.80
5	0.221	6.10	4.80	3.90	3.00	2.50	3.20	2.40	1.80	1.40	3.60	2.80	2.20
6	0.242	7.20	5.60	4.60	3.60	2.90	3.80	2.80	2.20	1.70	4.30	3.40	2.70
8	0.265	9.50	7.40	6.00	4.60	3.70	5.20	3.80	3.00	2.30	5.70	4.40	3.40
10	0.281	11.40	9.10	7.30	5.20	4.30	6.20	4.40	3.50	2.60	7.10	5.60	4.30
12	0.312	14.10	10.90	8.70	6.60	5.50	7.70	5.40	4.10	3.20	8.50	6.70	5.20
14	0.348	17.50	13.50	10.60	8.10	6.50	9.30	7.10	5.20	4.50	10.60	8.00	6.40
17	0.368	19.80	14.70	12.00	9.00	7.50	11.00	7.60	6.40	5.20	12.10	9.20	7.30
20	0.404	23.60	18.30	14.30	10.90	9.00	13.00	9.30	7.50	5.80	14.20	10.80	8.60
25	0.453	29.60	23.50	18.00	13.80	11.00	16.50	12.00	9.30	7.70	—	—	—
30	0.484	34.20	27.00	20.20	15.70	13.00	18.50	13.50	10.50	9.50	—	—	—

NOTE: Based on 100°F liquid entering expansion valve.
(1 Ton = 12,000 BTUH)

Table 4. Liquid Temperature Correction Factor

Liquid Temperature °F	30°	40°	50°	60°	70°	80°	90°	100°	110°	120°
Correction Factor	3.32	2.85	2.40	1.98	1.63	1.44	1.14	1.00	0.85	0.72

NOTE: Tons X Correction Factor = Nozzle Capacity

Nozzle Capacity (Tons) X 12,000 = BTUH Rating

Table 5. Pressure Drop vs. Nozzle Loading.

Nozzle PSI Drop	Group	Actual Load at a Percent of Above Rating									
		80%	90%	100%	110%	120%	130%	140%	150%	160%	170%
	*M	10	12	15	18	20	22	24	27	29	31
	*H	16	20	25	30	35	38	40	43	46	49

* M Group = R12, MP39, R134a.

* H Group = R22, R404A, R502, R507, HP80.

Unit Coolers

Recommended Unit Cooler Placement

Some general rules for evaporator placement which must be followed are:

1. The air pattern must cover the entire room.
2. **NEVER** locate evaporators over doors.
3. Location of aisles, racks, etc. must be known.

4. Location relative to compressors for minimum pipe runs.
5. Location of condensate drains for minimum run.

The size and shape of the storage will generally determine the type and number of evaporators to be used and their location. The following are some typical examples:

Minimum Unit Clearances

Figure 5 Intermediate and Large Unit Coolers

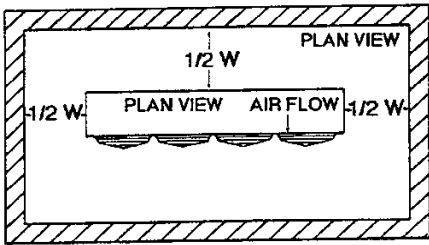

W = Total width of evaporator coil surface.

One evaporator

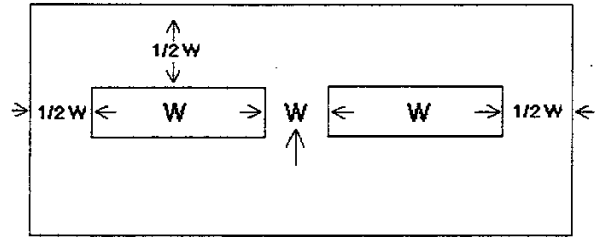

Two evaporators

Figure 6 Low Profile Unit Coolers

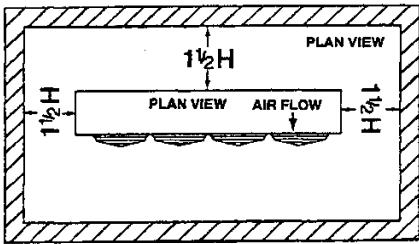

H = Total height evaporator coil surface.

One evaporator

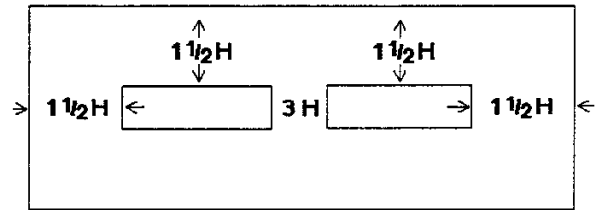

Two evaporators

Figure 7 Center Mount Unit Coolers

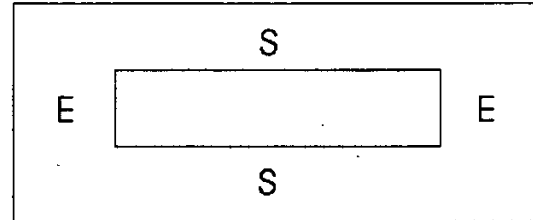
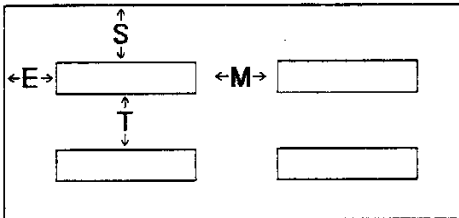

Recommended Maximum - Minimum Dimensions for Center Mount Unit Cooler Installations.

E		S		M		T	
Max.	Min.	Max.	Min.	Max.	Min.	Max.	Min.
25'	2'	20'	3'	40'	3'	40'	6'

NOTE: Leave space equal to unit height between bottom of unit and product. Do not stack product in front of fans.

Unit Cooler Mounting

Most evaporators can be mounted with rod hangers, lag screws, or bolts. Use $5/16"$ bolt and washers or rod for up to 250 pounds, $3/8"$ for up to 500 pounds and $5/8"$ for over 500 pounds. Care should be taken to mount the units level so that condensate drains properly. Adequate support must be provided to hold the weight of the unit.

When using rod hangers, allow adequate space between the top of the unit and the ceiling for cleaning. To comply with NSF

Standard 7, the area above the unit cooler must be sealed or exposed in such a way to facilitate hand cleaning without the use of tools. When lagging or bolting the unit flush to the ceiling, seal the joint between the top and the ceiling with an NSF listed sealant and ends of open hanger channels must be sealed to prevent accumulation of foreign matter.

When locating unit coolers in a cooler or freezer, refer to Figures 5 through 8 for guidelines.

Figure 8. Large Coolers and Freezers Placement.

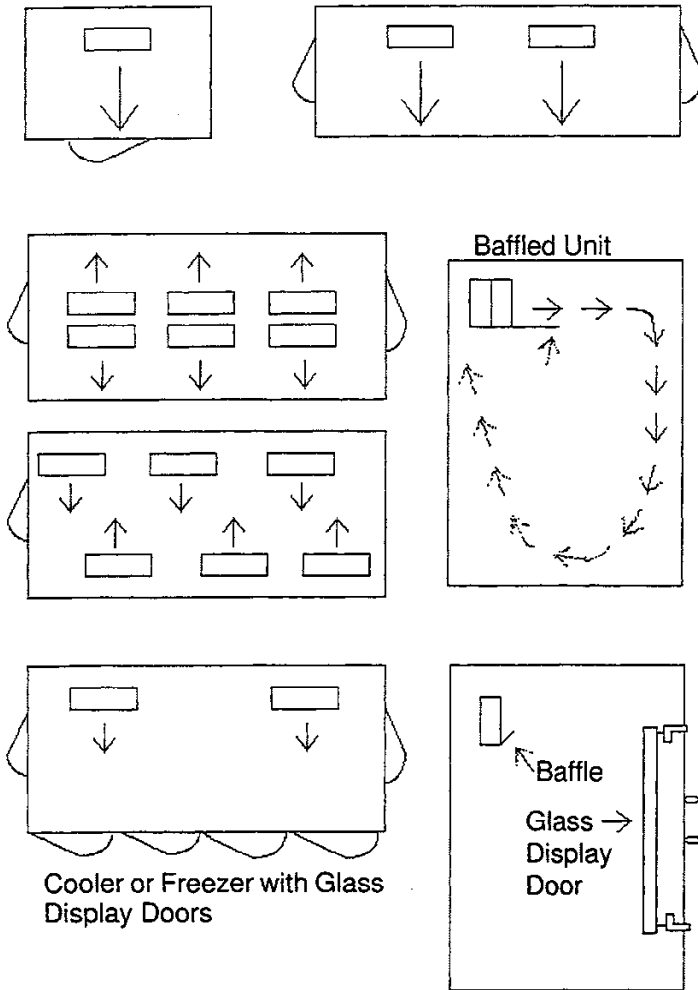

Where one wall evaporator mounting is satisfactory.

Cooler or Freezers where one wall will not accommodate all required evaporators or where air throw distance must be considered.

NOTE: Always avoid placement of Unit Coolers directly above doors and door openings where low temperature is being maintained and wherever possible for medium temperature.

Allow sufficient space between rear of Unit Cooler and wall to permit free return of air. Refer to Figures 5 through 7 for proper space.

NOTE: Always trap drain lines individually to prevent vapor migration.

Traps on low temperature units must be outside of refrigerated enclosures. Traps subject to freezing temperatures must be wrapped with heat tape and insulated.

Elevation view of glass display door cooler or freezer. Be sure air discharge blows above, not directly at doors. Provide baffle if door extends above blower level.

Condensing Unit Rigging and Mounting

Rigging holes are provided on all units. Caution should be exercised when moving these units. To prevent damage to the unit housing during rigging, cables or chains used must be held apart by spacer bars. The mounting platform or base should be level and located so as to permit free access of supply air.

Ground Mounting

Concrete slab raised six inches above ground level provides a suitable base. Raising the base above ground level provides some protection from ground water and wind blown matter. Before tightening mounting bolts, recheck level of unit. The unit should in all cases be located with a clear space in all directions that is at a minimum, equal to the height of the unit above the mounting surface. A condensing unit mounted in a corner formed by two walls, may result in discharge air recirculation with resulting loss of capacity.

Roof Mounting

Due to the weight of the units, a structural analysis by a qualified engineer may be required before mounting. Roof mounted units should be installed level on steel channels or an I-beam frame capable of supporting the weight of the unit. Vibration absorbing pads or springs should be installed between the condensing unit legs or frame and the roof mounting assembly.

Access

Provide adequate space at the compressor end of the unit for servicing. Provide adequate space on the connection side to permit service of components.

Spring Mounted Compressor

Compressors are secured rigidly to make sure there is no transit damage. Before operating the unit, it is necessary to follow these steps:

- a. Remove the upper nuts and washers.
- b. Discard the shipping spacers.
- c. Install the neoprene spacers. (Spacers located in the electrical panel or tied to compressor.)
- d. Replace the upper mounting nuts and washers.
- e. Allow 1/16 inch space between the mounting nut/washer and the neoprene spacer. See Figures 9 and 11 on page 10.

Rigid Mounted Compressor

Some products use rigid mounted compressors. Check the compressor mounting bolts to insure they have not vibrated loose during shipment. See Figure 10 on page 10.

Figure 9. Spring Mount

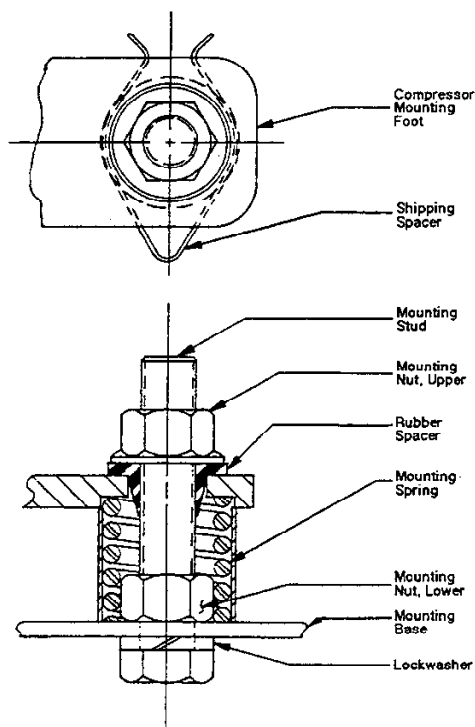

Figure 10. Solid Mount for Mobile or Deep Sump Application.

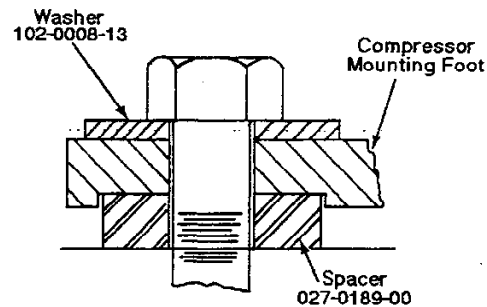
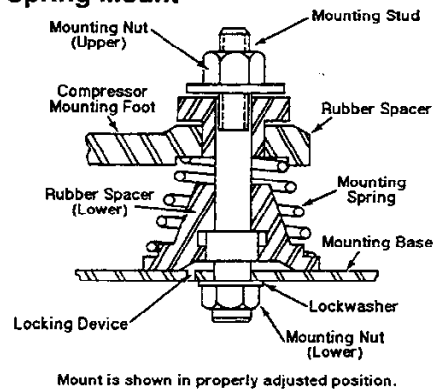

Figure 11. Spring Mount



Copeland Demand Cooling for L2 Models

R-22, when used in a properly designed and controlled refrigeration system, is a realistic low temperature refrigerant alternative to R-502, which must be phased out due to its high ozone depletion potential. However, experience has shown R-22 can present problems as a low temperature refrigerant because under some conditions the internal compressor discharge temperature exceeds the safe temperature limit for long term stability of refrigeration oil. For this reason suction to liquid heat exchangers are not recommended unless they are necessary to prevent another potential problem.

The Copeland Demand Cooling System

Copeland's demand cooling system uses modern electronics to provide a reliable, cost-effective solution to this problem. It is required for all single stage R-22 applications with saturated suction temperatures below -10°F.

The Demand Cooling module uses the signal of a discharge head temperature sensor to monitor discharge gas temperature. If a critical temperature is reached, the module energizes a long life injection valve which meters a controlled amount of saturated refrigerant into the compressor suction cavity to cool the suction gas. Refer to Figure 13.

This process controls the discharge temperature to a safe level. If, for some reason, the discharge temperature rises above a preset maximum level, the Demand Cooling module will turn the compressor off (requiring a manual reset) and actuate its alarm contact. To minimize the amount of refrigerant which must be injected, the suction gas cooling process is performed after the gas has passed around and through the motor.

Operating Range

Demand Cooling is designed to protect the compressor from high discharge temperatures over the evaporating and condensing temperature ranges shown in Figure 12 at a maximum return gas temperature of 65°F.

Demand Cooling System Design

When Demand Cooling operates, it "diverts" refrigeration capacity in the form of injected saturated refrigerant from the evaporator to the compressor. The effect of this diversion on evaporator capacity is minimal because the diverted capacity is used to cool the gas entering the compressor. As the gas is cooled, it naturally becomes more dense, increasing the mass flow through the compressor, which partly compensates for the capacity diverted from the evaporator.

1. **Compressor Return Gas Temperature:** Suction lines should be well insulated to reduce suction line heat gain. Return gas superheat should be as low as possible consistent with safe compressor operation. Minimum 20°F superheat at the compressor is required.
2. **Condensing Temperatures:** It is important when using R-22 as a low temperature refrigerant that condensing temperatures be minimized to reduce compression ratios and compressor discharge temperature.
3. **Suction Pressure:** Evaporator design and system control settings should provide the maximum suction pressure consistent with the application in order to have as low a compression ratio as possible.

In most cases, with floating head systems where condensing temperatures are low during most of the year, Demand Cooling will operate primarily as a compressor protection control much as the oil failure control protects the compressor during periods of low oil pressure. Demand Cooling will be allowed to operate only during those periods when condensing temperatures and return gas temperatures are high or in periods where a system failure (such as an iced evaporator, an expansion valve which does not control superheat, blocked condenser, or a failed condenser fan) raises condensing temperatures or return gas temperatures to abnormally high levels or lowers suction pressure to abnormally low levels.

Figure 12. Demand Cooling Injection

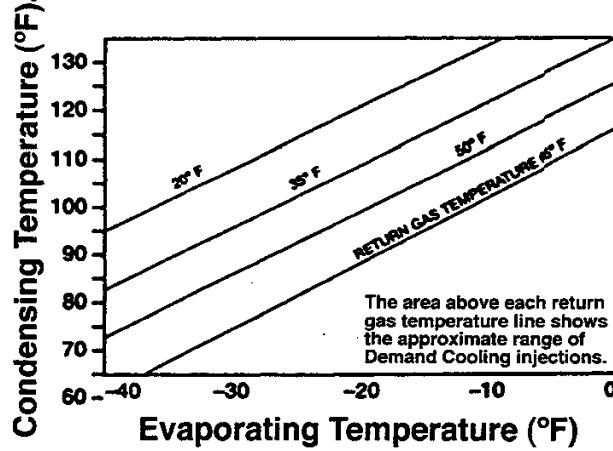
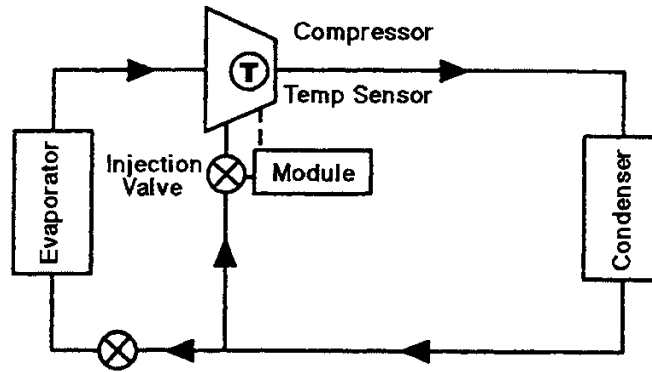

Figure 13. Single Stage Internal Refrigerant Injection



Line Sizing

The following Tables 10A through 13B on pages 14 through 21 indicate liquid lines and suction lines for all condensing units for R22, R502, R404A, R134a, R12 and R507.

When determining the refrigerant line length, be sure to add an allowance for fittings. See Table 7 below. Total equivalent length of refrigerant lines is the sum of the actual linear footage and the allowance for fittings.

Table 6. Pressure Loss of Liquid Refrigerants in Liquid Line Risers (Expressed in Pressure Drop, PSIG, and Subcooling Loss, °F).

Refrigerant	Liquid Line Rise in Feet																	
	10'		15'		20'		25'		30'		40'		50'		75'		100'	
	PSIG	'F	PSIG	'F	PSIG	'F	PSIG	'F	PSIG	'F	PSIG	'F	PSIG	'F	PSIG	'F	PSIG	'F
R12	5.4	2.8	8.1	4.2	10.7	5.4	13.4	6.9	16.1	8.3	21.5	11.3	26.9	14.3	40.3	22.4	53.7	31.0
R22	4.8	1.6	7.3	2.3	9.7	3.1	12.1	3.8	14.5	4.7	19.4	6.2	24.2	8.0	36.3	12.1	48.4	16.5
R502	4.9	1.5	7.3	2.2	9.7	3.0	12.1	3.7	14.6	4.5	19.5	6.0	24.3	7.6	36.4	11.5	48.6	14.8
R134a	4.9	2.0	7.4	2.9	9.8	4.1	12.3	5.2	14.7	6.3	19.7	8.8	24.6	11.0	36.8	17.0	49.1	23.7
R507, R404A	4.1	1.1	6.1	1.6	8.2	2.1	10.2	2.7	12.2	3.3	16.3	4.1	20.4	5.6	30.6	8.3	40.8	11.8

Based on 110°F liquid temperature at bottom of riser.

Table 7. Equivalent Feet of Pipe Due to Valve and Fitting Friction

Copper Tuber, O.D., Type "L"	1/2	5/8	7/8	1 1/8	1 3/8	1 5/8	2 1/8	2 5/8	3 1/8	3 5/8	4 1/8	5 1/8	6 1/8
Globe Valve (Open)	14	16	22	28	36	42	57	69	83	99	118	138	168
Angle Valve (Open)	7	9	12	15	18	21	28	34	42	49	57	70	83
90° Turn Through Tee	3	4	5	6	8	9	12	14	17	20	22	28	34
Tee (Straight Through) or Sweep Below	.75	1	1.5	2	2.5	3	3.5	4	5	6	7	9	11
90° Elbow or Reducing Tee (Straight Through)	1	2	2	3	4	4	5	7	8	10	12	14	16

Table 8. Weight of Refrigerants in Copper Lines During Operation (Pounds per 100 lineal feet of type "L" tubing).

Line Size O.D. in Inches	Refrigerant	Liquid Line	Hot Gas Line	Suction Line at Suction Temperature				
				-40°F	-20°F	0°F	+20°F	+40°F
3/8	12, 134a	4.0	.15	.01	.01	.02	.04	.06
	22	3.9	.22	.02	.03	.04	.06	.08
	R507, 502, 404A	3.4	.31	.03	.04	.06	.09	.13
1/2	12, 134a	7.4	.30	.01	.03	.04	.07	.11
	22	7.4	.41	.03	.05	.07	.11	.15
	R507, 502, 404A	6.4	.58	.04	.07	.13	.16	.24
5/8	12, 134a	11.9	.47	.02	.05	.07	.12	.17
	22	11.8	.65	.05	.08	.12	.17	.25
	R507, 502, 404A	10.3	.93	.07	.11	.17	.25	.35
7/8	12,134a	24.7	.99	.05	.10	.15	.24	.36
	22	24.4	1.35	.10	.16	.24	.36	.51
	R507, 502, 404A	21.2	1.92	.15	.23	.37	.51	.72
1 1/8	12,134a	42.2	1.70	.08	.17	.26	.41	.60
	22	41.6	2.30	.17	.28	.42	.61	.87
	R507, 502, 404A	36.1	3.27	.26	.39	.63	.86	1.24
1 3/8	12,134a	64.2	2.57	.14	.26	.40	.61	1.91
	22	63.5	3.50	.27	.42	.64	.93	1.33
	R507, 502, 404A	55.0	4.98	.40	.58	.95	1.32	1.87
1 5/8	12,134a	90.9	3.65	.20	.37	.57	.87	1.30
	22	90.0	4.96	.37	.59	.90	1.33	1.88
	R507, 502, 404A	78.0	7.07	.56	.82	1.35	1.86	2.64
2 1/8	12,134a	158	6.34	.34	.64	.98	1.51	2.24
	22	156	8.61	.65	1.03	1.57	2.30	3.26
	R507, 502, 404A	134	12.25	.98	1.43	2.35	3.23	4.58
2 5/8	12,134a	244	9.78	.52	.99	1.51	2.32	3.47
	22	241	13.70	1.01	1.59	2.42	3.54	5.03
	R507, 502, 404A	209	18.92	1.51	2.21	3.62	5.00	7.07
3 1/8	12, 134a	348	13.97	.75	1.41	2.16	3.31	4.96
	22	344	18.95	1.44	2.28	3.45	5.05	7.18
	R507, 502, 404A	298	27.05	2.16	3.15	5.17	7.14	9.95
3 5/8	12, 134a	471	18.90	.99	1.91	2.92	4.48	6.69
	22	465	25.60	1.94	3.08	4.67	6.83	9.74
	R507, 502, 404A	403	36.50	2.92	4.25	6.97	19.65	13.67
4 1/8	12,134a	612	24.56	1.29	2.49	3.81	5.84	8.75
	22	605	33.40	2.53	4.01	6.08	8.90	12.70
	R507, 502, 404A	526	47.57	3.80	5.55	9.09	12.58	17.80

Table 9. Recommended Remote Condenser Line Sizes

Net Evaporator Capacity	Total Equiv. Length	R-12 & R-134a		R-22		R-502		R507 & R-404A	
		Discharge Line (O.D.)	Liquid Line Cond. to Receiver (O.D.)	Discharge Line (O.D.)	Liquid Line Cond. to Receiver (O.D.)	Discharge Line (O.D.)	Liquid Line Cond. to Receiver (O.D.)	Discharge Line (O.D.)	Liquid Line Cond. to Receiver (O.D.)
3,000	50	3/8	3/8	3/8	3/8	3/8	3/8	3/8	3/8
	100	1/2	3/8	3/8	3/8	3/8	3/8	3/8	3/8
6,000	50	1/2	3/8	3/8	3/8	3/8	3/8	1/2	3/8
	100	1/2	3/8	1/2	3/8	1/2	3/8	1/2	3/8
9,000	50	5/8	3/8	1/2	3/8	1/2	3/8	1/2	3/8
	100	5/8	3/8	1/2	3/8	1/2	3/8	5/8	3/8
12,000	50	5/8	1/2	1/2	3/8	1/2	3/8	1/2	3/8
	100	7/8	1/2	5/8	3/8	5/8	3/8	5/8	3/8
18,000	50	7/8	1/2	1/2	3/8	5/8	1/2	5/8	1/2
	100	7/8	1/2	5/8	3/8	5/8	1/2	5/8	1/2
24,000	50	7/8	5/8	5/8	1/2	5/8	5/8	7/8	5/8
	100	7/8	5/8	5/8	1/2	7/8	5/8	7/8	5/8
36,000	50	7/8	5/8	7/8	5/8	7/8	5/8	7/8	5/8
	100	1 1/8	5/8	7/8	5/8	7/8	5/8	7/8	5/8
48,000	50	1 1/8	7/8	7/8	5/8	7/8	7/8	7/8	7/8
	100	1 1/8	7/8	7/8	5/8	7/8	7/8	1 1/8	7/8
60,000	50	1 1/8	7/8	7/8	7/8	1 1/8	7/8	7/8	7/8
	100	1 3/8	7/8	7/8	7/8	1 1/8	7/8	1 1/8	7/8
72,000	50	1 1/8	7/8	7/8	7/8	1 1/8	7/8	1 1/8	7/8
	100	1 3/8	7/8	1 1/8	7/8	1 1/8	7/8	1 1/8	7/8
90,000	50	1 3/8	7/8	7/8	7/8	1 1/8	1 1/8	1 1/8	1 1/8
	100	1 3/8	7/8	1 1/8	7/8	1 1/8	1 1/8	1 3/8	1 1/8
120,000	50	1 3/8	1 1/8	1 1/8	1 1/8	1 1/8	1 3/8	1 1/8	1 1/8
	100	1 5/8	1 1/8	1 1/8	1 1/8	1 3/8	1 3/8	1 3/8	1 1/8
180,000	50	1 5/8	1 3/8	1 3/8	1 3/8	1 3/8	1 3/8	1 3/8	1 3/8
	100	2 1/8	1 3/8	1 3/8	1 3/8	1 5/8	1 3/8	1 5/8	1 3/8
240,000	50	1 5/8	1 5/8	1 5/8	1 3/8	1 5/8	1 5/8	1 5/8	1 5/8
	100	2 1/8	1 5/8	1 5/8	1 3/8	1 5/8	1 5/8	1 5/8	1 5/8
300,000	50	2 1/8	1 5/8	1 5/8	1 5/8	1 5/8	1 5/8	1 5/8	2 1/8
	100	2 1/8	1 5/8	1 5/8	1 5/8	2 1/8	1 5/8	2 1/8	2 1/8
360,000	50	2 1/8	1 5/8	1 5/8	1 5/8	1 5/8	2 1/8	2 1/8	2 1/8
	100	2 5/8	1 5/8	2 1/8	1 5/8	2 1/8	2 1/8	2 1/8	2 1/8
480,000	50	2 1/8	2 1/8	2 1/8	2 1/8	2 1/8	2 1/8	2 1/8	2 1/8
	100	2 5/8	2 1/8	2 1/8	2 1/8	2 1/8	2 1/8	2 1/8	2 1/8
600,000	50	2 5/8	2 1/8	2 1/8	2 1/8	2 1/8	2 5/8	2 1/8	2 1/8
	100	3 1/8	2 1/8	2 1/8	2 1/8	2 5/8	2 5/8	2 5/8	2 1/8
720,000	50	2 5/8	2 5/8	2 1/8	2 5/8	2 1/8	3 1/8	2 1/8	2 5/8
	100	3 1/8	2 5/8	2 5/8	2 5/8	2 5/8	3 1/8	2 5/8	2 5/8
840,000	50	2 5/8	2 5/8	2 1/8	2 5/8	2 5/8	3 1/8	2 5/8	3 1/8
	100	3 1/8	2 5/8	2 5/8	2 5/8	2 5/8	3 1/8	2 5/8	3 1/8
960,000	50	3 1/8	3 1/8	2 5/8	3 1/8	2 5/8	3 1/8	2 5/8	3 1/8
	100	3 1/8	3 1/8	2 5/8	3 1/8	2 5/8	3 1/8	3 1/8	3 1/8
1,080,000	50	3 1/8	3 1/8	2 5/8	3 1/8	2 5/8	3 5/8	2 5/8	3 1/8
	100	3 5/8	3 1/8	2 5/8	3 1/8	3 1/8	3 5/8	3 1/8	3 1/8
1,200,000	50	3 1/8	3 5/8	2 5/8	3 1/8	2 5/8	3 5/8	2 5/8	3 5/8
	100	3 5/8	3 5/8	3 1/8	3 1/8	3 1/8	3 5/8	3 1/8	3 5/8
1,440,000	50	3 1/8	3 5/8	2 5/8	3 5/8	3 1/8	4 1/8	3 1/8	3 5/8
	100	3 5/8	3 5/8	3 1/8	3 5/8	3 1/8	4 1/8	3 5/8	3 5/8
1,680,000	50	3 5/8	4 1/8	2 5/8	3 5/8	3 1/8	4 1/8	3 1/8	4 1/8
	100	4 1/8	4 1/8	3 1/8	3 5/8	3 5/8	4 1/8	3 5/8	4 1/8

Table 10A. Recommended Line Sizes for R-134a *†#

SYSTEM CAPACITY BTU/H	SUCTION LINE SIZE																	
	SUCTION TEMPERATURE																	
	+40°F						+30°F						+20°F					
	Equivalent Lengths						Equivalent Lengths						Equivalent Lengths					
25'	50'	75'	100'	150'	200'	25'	50'	75'	100'	150'	200'	25'	50'	75'	100'	150'	200'	
1,000	3/8	3/8	3/8	3/8	3/8	1/2	3/8	3/8	3/8	3/8	1/2	1/2	3/8	1/2	1/2	1/2	1/2	5/8
3,000	3/8	1/2	1/2	1/2	5/8	5/8	1/2	1/2	1/2	5/8	5/8	5/8	1/2	5/8	5/8	7/8	7/8	7/8
4,000	1/2	1/2	5/8	5/8	5/8	5/8	1/2	1/2	5/8	5/8	5/8	7/8	5/8	5/8	7/8	7/8	7/8	7/8
6,000	1/2	5/8	5/8	5/8	7/8	7/8	1/2	5/8	5/8	7/8	7/8	7/8	5/8	5/8	7/8	7/8	7/8	7/8
9,000	5/8	5/8	7/8	7/8	7/8	7/8	5/8	7/8	7/8	7/8	7/8	7/8	5/8	7/8	7/8	7/8	7/8	1 1/8
12,000	5/8	7/8	7/8	7/8	7/8	7/8	7/8	7/8	7/8	1 1/8	1 1/8	1 1/8	7/8	7/8	7/8	1 1/8	1 1/8	1 1/8
15,000	7/8	7/8	7/8	7/8	1 1/8	1 1/8	7/8	7/8	7/8	1 1/8	1 1/8	1 1/8	7/8	7/8	7/8	1 1/8	1 1/8	1 1/8
18,000	7/8	7/8	7/8	7/8	1 1/8	1 1/8	7/8	7/8	1 1/8	1 1/8	1 1/8	1 1/8	7/8	7/8	1 1/8	1 1/8	1 1/8	1 3/8
24,000	7/8	7/8	1 1/8	1 1/8	1 1/8	1 1/8	7/8	1 1/8	1 1/8	1 1/8	1 3/8	1 3/8	7/8	1 1/8	1 1/8	1 1/8	1 3/8	1 3/8
30,000	7/8	1 1/8	1 1/8	1 1/8	1 3/8	1 3/8	7/8	1 1/8	1 1/8	1 3/8	1 3/8	1 3/8	1 1/8	1 1/8	1 1/8	1 3/8	1 3/8	1 3/8
36,000	7/8	1 1/8	1 1/8	1 1/8	1 3/8	1 3/8	1 1/8	1 1/8	1 3/8	1 3/8	1 3/8	1 5/8	1 1/8	1 1/8	1 3/8	1 3/8	1 5/8	1 5/8
42,000	1 1/8	1 1/8	1 1/8	1 3/8	1 3/8	1 3/8	1 1/8	1 1/8	1 3/8	1 3/8	1 5/8	1 5/8	1 1/8	1 3/8	1 3/8	1 3/8	1 5/8	1 5/8
48,000	1 1/8	1 1/8	1 3/8	1 3/8	1 3/8	1 5/8	1 1/8	1 3/8	1 3/8	1 3/8	1 5/8	1 5/8	1 1/8	1 3/8	1 5/8	1 5/8	1 5/8	1 5/8
54,000	1 1/8	1 1/8	1 3/8	1 3/8	1 5/8	1 5/8	1 1/8	1 3/8	1 3/8	1 5/8	1 5/8	1 5/8	1 1/8	1 3/8	1 5/8	1 5/8	1 5/8	2 1/8
60,000	1 1/8	1 3/8	1 3/8	1 3/8	1 5/8	1 5/8	1 1/8	1 3/8	1 3/8	1 5/8	1 5/8	2 1/8	1 3/8	1 3/8	1 5/8	1 5/8	2 1/8	2 1/8
66,000	1 1/8	1 3/8	1 3/8	1 5/8	1 5/8	1 5/8	1 3/8	1 3/8	1 5/8	1 5/8	2 1/8	2 1/8	1 3/8	1 5/8	1 5/8	1 5/8	2 1/8	2 1/8
72,000	1 1/8	1 3/8	1 5/8	1 5/8	1 5/8	2 1/8	1 3/8	1 3/8	1 5/8	1 5/8	2 1/8	2 1/8	1 3/8	1 5/8	2 1/8	2 1/8	2 1/8	2 1/8
78,000	1 1/8	1 3/8	1 5/8	1 5/8	1 5/8	2 1/8	1 3/8	1 5/8	1 5/8	1 5/8	2 1/8	2 1/8	1 3/8	1 5/8	2 1/8	2 1/8	2 1/8	2 1/8
84,000	1 3/8	1 3/8	1 5/8	1 5/8	2 1/8	2 1/8	1 3/8	1 5/8	1 5/8	2 1/8	2 1/8	2 1/8	1 3/8	1 5/8	2 1/8	2 1/8	2 1/8	2 1/8
90,000	1 3/8	1 3/8	1 5/8	1 5/8	2 1/8	2 1/8	1 3/8	1 5/8	1 5/8	2 1/8	2 1/8	2 1/8	1 3/8	1 5/8	2 1/8	2 1/8	2 1/8	2 1/8
120,000	1 3/8	1 5/8	2 1/8	2 1/8	2 1/8	2 1/8	1 5/8	1 5/8	2 1/8	2 1/8	2 1/8	2 5/8	1 5/8	2 1/8	2 1/8	2 1/8	2 5/8	2 5/8
150,000	1 5/8	2 1/8	2 1/8	2 1/8	2 1/8	2 5/8	1 5/8	2 1/8	2 1/8	2 1/8	2 5/8	2 5/8	2 1/8	2 1/8	2 5/8	2 5/8	2 5/8	2 5/8
180,000	1 5/8	2 1/8	2 1/8	2 1/8	2 5/8	2 5/8	1 5/8	2 1/8	2 1/8	2 5/8	2 5/8	2 5/8	2 1/8	2 1/8	2 5/8	2 5/8	2 5/8	3 1/8
210,000	1 5/8	2 1/8	2 1/8	2 1/8	2 5/8	2 5/8	2 1/8	2 1/8	2 5/8	2 5/8	2 5/8	3 1/8	2 1/8	2 1/8	2 5/8	2 5/8	3 1/8	3 1/8
240,000	2 1/8	2 1/8	2 1/8	2 5/8	2 5/8	2 5/8	2 1/8	2 1/8	2 5/8	2 5/8	2 5/8	3 1/8	2 1/8	2 5/8	2 5/8	2 5/8	3 1/8	3 1/8
300,000	2 1/8	2 1/8	2 5/8	2 5/8	2 5/8	3 1/8	2 1/8	2 5/8	2 5/8	2 5/8	3 1/8	3 1/8	2 1/8	2 5/8	3 1/8	3 1/8	3 1/8	3 5/8
360,000	2 1/8	2 5/8	2 5/8	2 5/8	3 1/8	3 1/8	2 1/8	2 5/8	2 5/8	3 1/8	3 1/8	3 5/8	2 5/8	3 1/8	3 5/8	3 5/8	4 1/8	4 1/8
480,000	2 5/8	2 5/8	3 1/8	3 1/8	3 1/8	3 5/8	2 5/8	3 1/8	3 1/8	3 1/8	3 5/8	3 5/8	3 1/8	3 5/8	3 5/8	4 1/8	5 1/8	5 1/8
600,000	2 5/8	3 1/8	3 1/8	3 1/8	3 5/8	3 5/8	2 5/8	3 1/8	3 1/8	3 5/8	3 5/8	4 1/8	3 1/8	3 5/8	4 1/8	4 1/8	5 1/8	5 1/8

* Sizes that are highlighted indicate maximum suction line sizes that should be used for risers. Riser size should not exceed horizontal size. Properly placed suction traps must also be used for adequate oil return.

All sizes shown are for O.D. Type L copper tubing.

† Recommended line sizes for R-12 also.

Suction line sizes selected at pressure drop equivalent to 2°F. Reduce estimate of system capacity accordingly.

NOTE: Consult factory for R-134a, R-12 operation at winter conditions below 0° ambient.

Heated and insulated receiver required below 0° ambient.

If system load drops below 40% of design, consideration to installing double suction risers should be made.

Table 10B. Recommended Line Sizes for R-134a (continued) *†#

SUCTION LINE SIZE												LIQUID LINE SIZE						SYSTEM CAPACITY BTU/H
SUCTION TEMPERATURE												Receiver to						
+10°F						0°F						Expansion Valve						
Equivalent Lengths						Equivalent Lengths						Equivalent Lengths						
25'	50'	75'	100'	150'	200'	25'	50'	75'	100'	150'	200'	25'	50'	75'	100'	150'	200'	
3/8	1/2	1/2	1/2	1/2	5/8	3/8	1/2	1/2	1/2	1/2	5/8	3/8	3/8	3/8	3/8	3/8	3/8	1,000
1/2	5/8	5/8	7/8	7/8	7/8	1/2	5/8	5/8	7/8	7/8	7/8	3/8	3/8	3/8	3/8	3/8	3/8	3,000
5/8	5/8	7/8	7/8	7/8	7/8	5/8	5/8	7/8	7/8	7/8	7/8	3/8	3/8	3/8	3/8	3/8	3/8	4,000
5/8	7/8	7/8	7/8	1 1/8	1 1/8	5/8	7/8	7/8	7/8	7/8	1 1/8	3/8	3/8	3/8	3/8	3/8	3/8	6,000
7/8	7/8	7/8	1 1/8	1 1/8	1 1/8	7/8	7/8	7/8	1 1/8	1 1/8	1 1/8	3/8	3/8	3/8	3/8	3/8	1/2	9,000
7/8	7/8	1 1/8	1 1/8	1 1/8	1 3/8	7/8	1 1/8	1 1/8	1 1/8	1 1/8	1 3/8	3/8	3/8	3/8	3/8	1/2	1/2	12,000
7/8	1 1/8	1 1/8	1 1/8	1 3/8	1 3/8	7/8	1 1/8	1 1/8	1 1/8	1 3/8	1 3/8	3/8	3/8	3/8	1/2	1/2	1/2	15,000
1 1/8	1 1/8	1 1/8	1 3/8	1 3/8	1 3/8	1 1/8	1 1/8	1 1/8	1 3/8	1 3/8	1 3/8	3/8	3/8	1/2	1/2	1/2	1/2	18,000
1 1/8	1 1/8	1 3/8	1 3/8	1 3/8	1 5/8	1 1/8	1 1/8	1 3/8	1 3/8	1 5/8	1 5/8	3/8	1/2	1/2	1/2	1/2	5/8	24,000
1 1/8	1 3/8	1 3/8	1 3/8	1 5/8	1 5/8	1 1/8	1 3/8	1 3/8	1 5/8	1 5/8	1 5/8	1/2	1/2	1/2	1/2	5/8	5/8	30,000
1 3/8	1 3/8	1 3/8	1 5/8	1 5/8	2 1/8	1 3/8	1 3/8	1 5/8	1 5/8	1 5/8	2 1/8	1/2	1/2	1/2	5/8	5/8	5/8	36,000
1 3/8	1 5/8	1 5/8	2 1/8	2 1/8	2 1/8	1 3/8	1 3/8	1 5/8	1 5/8	2 1/8	2 1/8	1/2	1/2	5/8	5/8	5/8	5/8	42,000
1 3/8	1 5/8	1 5/8	2 1/8	2 1/8	2 1/8	1 3/8	1 5/8	1 5/8	2 1/8	2 1/8	2 1/8	1/2	5/8	5/8	5/8	5/8	7/8	48,000
1 3/8	1 5/8	2 1/8	2 1/8	2 1/8	2 1/8	1 3/8	1 5/8	1 5/8	2 1/8	2 1/8	2 1/8	1/2	5/8	5/8	5/8	7/8	7/8	54,000
1 5/8	1 5/8	2 1/8	2 1/8	2 1/8	2 1/8	1 3/8	2 1/8	2 1/8	2 1/8	2 1/8	2 1/8	5/8	5/8	5/8	5/8	7/8	7/8	60,000
1 5/8	2 1/8	2 1/8	2 1/8	2 1/8	2 5/8	1 5/8	2 1/8	2 1/8	2 1/8	2 1/8	2 1/8	5/8	5/8	5/8	7/8	7/8	7/8	66,000
1 5/8	2 1/8	2 1/8	2 1/8	2 5/8	2 5/8	1 5/8	2 1/8	2 1/8	2 1/8	2 1/8	2 5/8	5/8	5/8	7/8	7/8	7/8	7/8	72,000
1 5/8	2 1/8	2 1/8	2 1/8	2 5/8	2 5/8	1 5/8	2 1/8	2 1/8	2 1/8	2 5/8	2 5/8	5/8	5/8	7/8	7/8	7/8	7/8	78,000
1 5/8	2 1/8	2 1/8	2 1/8	2 5/8	2 5/8	1 5/8	2 1/8	2 1/8	2 1/8	2 5/8	2 5/8	5/8	7/8	7/8	7/8	7/8	7/8	84,000
1 5/8	2 1/8	2 1/8	2 5/8	2 5/8	2 5/8	1 5/8	2 1/8	2 1/8	2 1/8	2 5/8	2 5/8	5/8	7/8	7/8	7/8	7/8	7/8	90,000
2 1/8	2 1/8	2 5/8	2 5/8	2 5/8	3 1/8	2 1/8	2 1/8	2 5/8	2 5/8	2 5/8	3 1/8	7/8	7/8	7/8	7/8	7/8	1 1/8	120,000
2 1/8	2 5/8	2 5/8	2 5/8	3 1/8	3 1/8	2 1/8	2 5/8	2 5/8	2 5/8	3 1/8	3 1/8	7/8	7/8	7/8	7/8	1 1/8	1 1/8	150,000
2 1/8	2 5/8	2 5/8	3 1/8	3 1/8	3 1/8	2 1/8	2 5/8	2 5/8	3 1/8	3 1/8	3 1/8	7/8	7/8	7/8	1 1/8	1 1/8	1 1/8	180,000
2 5/8	2 5/8	3 1/8	3 1/8	3 5/8	3 5/8	2 5/8	2 5/8	2 5/8	3 1/8	3 1/8	3 5/8	7/8	7/8	1 1/8	1 1/8	1 1/8	1 1/8	210,000
2 5/8	2 5/8	3 1/8	3 1/8	3 5/8	3 5/8	2 5/8	2 5/8	3 1/8	3 1/8	3 5/8	3 5/8	7/8	1 1/8	1 1/8	1 1/8	1 1/8	1 3/8	240,000
2 5/8	3 1/8	3 1/8	3 5/8	3 5/8	4 1/8	2 5/8	3 1/8	3 1/8	3 5/8	3 5/8	4 1/8	1 1/8	1 1/8	1 1/8	1 1/8	1 3/8	1 3/8	300,000
2 5/8	3 1/8	3 5/8	3 5/8	4 1/8	4 1/8	2 5/8	3 1/8	3 5/8	3 5/8	4 1/8	4 1/8	1 1/8	1 1/8	1 1/8	1 3/8	1 3/8	1 5/8	360,000
3 1/8	3 5/8	3 5/8	4 1/8	5 1/8	5 1/8	3 1/8	3 5/8	3 5/8	4 1/8	5 1/8	5 1/8	1 1/8	1 1/8	1 3/8	1 3/8	1 5/8	1 5/8	480,000
3 1/8	3 5/8	4 1/8	5 1/8	5 1/8	5 1/8	3 1/8	3 5/8	4 1/8	4 1/8	5 1/8	5 1/8	1 3/8	1 3/8	1 3/8	1 5/8	1 5/8	1 5/8	600,000

* Sizes that are highlighted indicate maximum suction line sizes that should be used for risers. Riser size should not exceed horizontal size. Properly placed suction traps must also be used for adequate oil return. All sizes shown are for O.D. Type L copper tubing.

† Recommended line sizes for R-12 also.

Suction line sizes selected at pressure drop equivalent to 2°F. Reduce estimate of system capacity accordingly.

NOTE: Consult factory for R-134a, R-12 operation at winter conditions below 0° ambient.

Heated and insulated receiver required below 0° ambient.

If system load drops below 40% of design, consideration to installing double suction risers should be made.

Table 11A. Recommended Line Sizes for R-22 *#

SYSTEM CAPACITY BTU/H	SUCTION LINE SIZE																				
	SUCTION TEMPERATURE																				
	+40°F						+20°F						+10°F						0°F		
	Equivalent Lengths						Equivalent Lengths						Equivalent Lengths						Equivalent		
25'	50'	75'	100'	150'	200'	25'	50'	75'	100'	150'	200'	25'	50'	75'	100'	150'	200'	25'	50'	75'	
1,000	3/8	3/8	3/8	3/8	3/8	3/8	3/8	3/8	3/8	3/8	3/8	3/8	3/8	3/8	3/8	3/8	1/2	3/8	3/8	3/8	
3,000	3/8	3/8	3/8	1/2	1/2	1/2	3/8	1/2	1/2	1/2	5/8	5/8	3/8	1/2	1/2	1/2	5/8	5/8	1/2	1/2	1/2
4,000	3/8	3/8	1/2	1/2	1/2	1/2	3/8	1/2	1/2	1/2	5/8	5/8	1/2	1/2	1/2	5/8	5/8	5/8	1/2	1/2	5/8
6,000	1/2	1/2	1/2	5/8	5/8	5/8	1/2	1/2	5/8	5/8	5/8	1/2	5/8	5/8	5/8	7/8	7/8	5/8	5/8	5/8	5/8
9,000	1/2	5/8	5/8	5/8	7/8	7/8	1/2	5/8	5/8	5/8	7/8	7/8	5/8	5/8	7/8	7/8	7/8	7/8	5/8	7/8	7/8
12,000	5/8	5/8	5/8	7/8	7/8	7/8	5/8	5/8	7/8	7/8	7/8	7/8	5/8	7/8	7/8	7/8	7/8	7/8	5/8	7/8	7/8
15,000	5/8	5/8	7/8	7/8	7/8	7/8	5/8	7/8	7/8	7/8	7/8	7/8	7/8	7/8	7/8	7/8	1 1/8	1 1/8	7/8	7/8	7/8
18,000	5/8	7/8	7/8	7/8	7/8	1 1/8	5/8	7/8	7/8	7/8	7/8	1 1/8	7/8	7/8	7/8	7/8	1 1/8	1 1/8	7/8	7/8	1 1/8
24,000	5/8	7/8	7/8	7/8	1 1/8	1 1/8	7/8	7/8	7/8	7/8	1 1/8	1 1/8	7/8	7/8	1 1/8	1 1/8	1 1/8	1 1/8	7/8	1 1/8	1 1/8
30,000	7/8	7/8	7/8	1 1/8	1 1/8	1 1/8	7/8	7/8	7/8	1 1/8	1 1/8	1 1/8	7/8	1 1/8	1 1/8	1 1/8	1 1/8	1 1/8	1 1/8	1 1/8	1 1/8
36,000	7/8	1 1/8	1 1/8	1 1/8	1 1/8	1 3/8	7/8	1 1/8	1 1/8	1 1/8	1 1/8	1 3/8	7/8	1 1/8	1 1/8	1 1/8	1 3/8	1 3/8	1 1/8	1 1/8	1 1/8
42,000	7/8	1 1/8	1 1/8	1 1/8	1 1/8	1 3/8	7/8	1 1/8	1 1/8	1 1/8	1 3/8	1 3/8	1 1/8	1 1/8	1 1/8	1 3/8	1 3/8	1 3/8	1 1/8	1 1/8	1 3/8
48,000	7/8	1 1/8	1 1/8	1 1/8	1 1/8	1 3/8	7/8	1 1/8	1 1/8	1 1/8	1 3/8	1 3/8	1 1/8	1 1/8	1 3/8	1 3/8	1 3/8	1 3/8	1 1/8	1 3/8	1 3/8
54,000	7/8	1 1/8	1 1/8	1 1/8	1 3/8	1 3/8	1 1/8	1 1/8	1 1/8	1 3/8	1 3/8	1 3/8	1 1/8	1 3/8	1 3/8	1 3/8	1 5/8	1 5/8	1 1/8	1 3/8	1 3/8
60,000	7/8	1 1/8	1 1/8	1 1/8	1 3/8	1 3/8	1 1/8	1 1/8	1 1/8	1 3/8	1 3/8	1 5/8	1 1/8	1 3/8	1 3/8	1 3/8	1 5/8	1 5/8	1 1/8	1 3/8	1 3/8
66,000	7/8	1 1/8	1 1/8	1 3/8	1 3/8	1 3/8	1 1/8	1 1/8	1 3/8	1 3/8	1 3/8	1 5/8	1 1/8	1 3/8	1 3/8	1 3/8	1 5/8	1 5/8	1 1/8	1 3/8	1 5/8
72,000	1 1/8	1 1/8	1 1/8	1 3/8	1 3/8	1 3/8	1 1/8	1 3/8	1 3/8	1 3/8	1 5/8	1 5/8	1 1/8	1 3/8	1 3/8	1 5/8	1 5/8	1 5/8	1 3/8	1 3/8	1 5/8
78,000	1 1/8	1 1/8	1 3/8	1 3/8	1 3/8	1 5/8	1 1/8	1 3/8	1 3/8	1 3/8	1 5/8	1 5/8	1 1/8	1 3/8	1 5/8	1 5/8	1 5/8	2 1/8	1 3/8	1 3/8	1 5/8
84,000	1 1/8	1 1/8	1 3/8	1 3/8	1 3/8	1 5/8	1 1/8	1 3/8	1 3/8	1 3/8	1 5/8	1 5/8	1 3/8	1 3/8	1 5/8	1 5/8	1 5/8	2 1/8	1 3/8	1 5/8	1 5/8
90,000	1 1/8	1 3/8	1 3/8	1 3/8	1 5/8	1 5/8	1 1/8	1 3/8	1 3/8	1 5/8	1 5/8	2 1/8	1 3/8	1 3/8	1 5/8	1 5/8	2 1/8	2 1/8	1 3/8	1 5/8	1 5/8
120,000	1 1/8	1 3/8	1 3/8	1 5/8	1 5/8	2 1/8	1 3/8	1 3/8	1 5/8	1 5/8	2 1/8	2 1/8	1 3/8	1 5/8	1 5/8	2 1/8	2 1/8	2 1/8	1 5/8	1 5/8	2 1/8
150,000	1 3/8	1 3/8	1 5/8	1 5/8	2 1/8	2 1/8	1 3/8	1 5/8	1 5/8	2 1/8	2 1/8	2 1/8	2 1/8	1 5/8	1 5/8	2 1/8	2 1/8	2 1/8	1 5/8	2 1/8	2 1/8
180,000	1 3/8	1 5/8	1 5/8	2 1/8	2 1/8	2 1/8	1 3/8	1 5/8	2 1/8	2 1/8	2 1/8	2 1/8	1 5/8	2 1/8	2 1/8	2 1/8	2 5/8	2 5/8	1 5/8	2 1/8	2 1/8
210,000	1 3/8	1 5/8	1 5/8	2 1/8	2 1/8	2 1/8	1 5/8	2 1/8	2 1/8	2 1/8	2 1/8	2 5/8	1 5/8	2 1/8	2 1/8	2 1/8	2 5/8	2 5/8	2 1/8	2 1/8	2 1/8
240,000	1 5/8	1 5/8	2 1/8	2 1/8	2 1/8	2 5/8	1 5/8	2 1/8	2 1/8	2 1/8	2 5/8	2 5/8	2 1/8	2 1/8	2 1/8	2 5/8	2 5/8	2 1/8	2 1/8	2 1/8	2 5/8
300,000	1 5/8	2 1/8	2 1/8	2 1/8	2 5/8	2 5/8	2 1/8	2 1/8	2 1/8	2 5/8	2 5/8	2 5/8	2 1/8	2 1/8	2 5/8	2 5/8	2 5/8	2 5/8	2 1/8	2 5/8	2 5/8
360,000	2 1/8	2 1/8	2 1/8	2 5/8	2 5/8	2 5/8	2 1/8	2 1/8	2 5/8	2 5/8	2 5/8	2 5/8	2 1/8	2 5/8	2 5/8	2 5/8	3 1/8	3 1/8	2 1/8	2 5/8	2 5/8
480,000	2 1/8	2 1/8	2 5/8	2 5/8	2 5/8	3 1/8	2 1/8	2 5/8	2 5/8	2 5/8	3 1/8	3 1/8	2 1/8	2 5/8	2 5/8	3 1/8	3 1/8	3 5/8	2 5/8	2 5/8	3 1/8
600,000	2 1/8	2 5/8	2 5/8	2 5/8	3 1/8	3 1/8	2 1/8	2 5/8	3 1/8	3 1/8	3 5/8	3 5/8	2 5/8	2 5/8	3 1/8	3 1/8	3 5/8	3 5/8	2 5/8	3 1/8	3 1/8

* Sizes that are highlighted indicate maximum suction line sizes that should be used for risers. Riser size should not exceed horizontal size. Properly placed suction traps must also be used for adequate oil return.
 All sizes shown are for O.D. Type L copper tubing.
 # Suction line sizes selected at pressure drop equivalent to 2°F. reduce estimate of system capacity accordingly.
 If system load drops below 40% of design, consideration to installing double suction risers should be made.

Table 11B. Recommended Line Sizes for R-22 (continued) *#

SUCTION LINE SIZE															LIQUID LINE SIZE						SYSTEM CAPACITY BTU/H					
SUCTION TEMPERATURE															Receiver to											
0°F			-10°F						-20°F						Expansion Valve											
Lengths			Equivalent Lengths						Equivalent Lengths						Equivalent Lengths											
100'	150'	200'	25'	50'	75'	100'	150'	200'	25'	50'	75'	100'	150'	200'	25'	50'	75'	100'	150'	200'	25'	50'	75'	100'	150'	200'
3/8	1/2	1/2	3/8	3/8	3/8	3/8	1/2	1/2	3/8	3/8	3/8	1/2	1/2	1/2	3/8	3/8	3/8	3/8	3/8	3/8	3/8	3/8	3/8	3/8	3/8	1,000
5/8	5/8	5/8	1/2	1/2	1/2	5/8	5/8	5/8	1/2	1/2	5/8	5/8	5/8	7/8	3/8	3/8	3/8	3/8	3/8	3/8	3/8	3/8	3/8	3/8	3/8	3,000
5/8	5/8	7/8	1/2	1/2	5/8	5/8	5/8	7/8	1/2	5/8	5/8	5/8	7/8	7/8	3/8	3/8	3/8	3/8	3/8	3/8	3/8	3/8	3/8	3/8	3/8	4,000
5/8	7/8	7/8	1/2	5/8	5/8	7/8	7/8	7/8	5/8	5/8	7/8	7/8	7/8	7/8	3/8	3/8	3/8	3/8	3/8	3/8	3/8	3/8	3/8	3/8	3/8	6,000
7/8	7/8	7/8	5/8	7/8	7/8	7/8	7/8	7/8	5/8	7/8	7/8	7/8	7/8	1 1/8	3/8	3/8	3/8	3/8	3/8	3/8	3/8	3/8	3/8	3/8	3/8	9,000
7/8	7/8	1 1/8	7/8	7/8	7/8	7/8	1 1/8	1 1/8	7/8	7/8	7/8	1 1/8	1 1/8	1 1/8	3/8	3/8	3/8	3/8	3/8	3/8	3/8	3/8	3/8	3/8	3/8	12,000
7/8	1 1/8	1 1/8	7/8	7/8	7/8	1 1/8	1 1/8	1 1/8	7/8	7/8	1 1/8	1 1/8	1 1/8	1 1/8	3/8	3/8	3/8	3/8	3/8	3/8	3/8	3/8	1/2	1/2	1/2	15,000
1 1/8	1 1/8	1 1/8	7/8	7/8	1 1/8	1 1/8	1 1/8	1 1/8	7/8	1 1/8	1 1/8	1 1/8	1 1/8	1 3/8	3/8	3/8	3/8	3/8	3/8	3/8	1/2	1/2	1/2	1/2	1/2	18,000
1 1/8	1 1/8	1 3/8	7/8	1 1/8	1 1/8	1 1/8	1 3/8	1 3/8	7/8	1 1/8	1 1/8	1 3/8	1 3/8	1 3/8	3/8	3/8	1/2	1/2	1/2	1/2	1/2	1/2	1/2	1/2	1/2	24,000
1 1/8	1 3/8	1 3/8	7/8	1 1/8	1 1/8	1 3/8	1 3/8	1 3/8	1 1/8	1 1/8	1 3/8	1 3/8	1 3/8	1 5/8	3/8	3/8	1/2	1/2	1/2	1/2	1/2	1/2	1/2	1/2	1/2	30,000
1 3/8	1 3/8	1 3/8	1 1/8	1 1/8	1 3/8	1 3/8	1 3/8	1 3/8	1 1/8	1 3/8	1 3/8	1 3/8	1 3/8	1 5/8	3/8	1/2	1/2	1/2	1/2	1/2	1/2	1/2	1/2	1/2	1/2	36,000
1 3/8	1 3/8	1 5/8	1 1/8	1 1/8	1 3/8	1 3/8	1 5/8	1 5/8	1 1/8	1 3/8	1 3/8	1 5/8	1 5/8	1 5/8	3/8	1/2	1/2	1/2	1/2	1/2	1/2	1/2	5/8	5/8	5/8	42,000
1 3/8	1 5/8	1 5/8	1 1/8	1 3/8	1 3/8	1 3/8	1 5/8	1 5/8	1 1/8	1 3/8	1 3/8	1 5/8	1 5/8	2 1/8	1/2	1/2	1/2	1/2	1/2	1/2	1/2	5/8	5/8	5/8	5/8	48,000
1 3/8	1 5/8	1 5/8	1 1/8	1 3/8	1 3/8	1 5/8	1 5/8	1 5/8	1 3/8	1 3/8	1 5/8	1 5/8	2 1/8	2 1/8	1/2	1/2	1/2	1/2	1/2	5/8	5/8	5/8	5/8	5/8	5/8	54,000
1 5/8	1 5/8	2 1/8	1 1/8	1 3/8	1 3/8	1 5/8	1 5/8	2 1/8	1 3/8	1 3/8	1 5/8	1 5/8	2 1/8	2 1/8	1/2	1/2	1/2	1/2	1/2	5/8	5/8	5/8	5/8	5/8	5/8	60,000
1 5/8	1 5/8	2 1/8	1 3/8	1 3/8	1 5/8	1 5/8	1 5/8	2 1/8	1 3/8	1 5/8	1 5/8	1 5/8	2 1/8	2 1/8	1/2	1/2	5/8	5/8	5/8	5/8	5/8	5/8	5/8	5/8	5/8	66,000
1 5/8	2 1/8	2 1/8	1 3/8	1 3/8	1 5/8	1 5/8	2 1/8	2 1/8	1 3/8	1 5/8	1 5/8	2 1/8	2 1/8	2 1/8	1/2	1/2	5/8	5/8	5/8	5/8	5/8	5/8	5/8	5/8	5/8	72,000
1 5/8	2 1/8	2 1/8	1 3/8	1 5/8	1 5/8	1 5/8	2 1/8	2 1/8	1 3/8	1 5/8	1 5/8	2 1/8	2 1/8	2 1/8	1/2	1/2	5/8	5/8	5/8	5/8	5/8	5/8	7/8	7/8	7/8	78,000
1 5/8	2 1/8	2 1/8	1 3/8	1 5/8	1 5/8	2 1/8	2 1/8	2 1/8	1 3/8	1 5/8	2 1/8	2 1/8	2 1/8	2 1/8	1/2	5/8	5/8	5/8	5/8	5/8	5/8	5/8	7/8	7/8	7/8	84,000
2 1/8	2 1/8	2 1/8	1 3/8	1 5/8	1 5/8	2 1/8	2 1/8	2 1/8	1 3/8	1 5/8	2 1/8	2 1/8	2 1/8	2 1/8	1/2	5/8	5/8	5/8	5/8	5/8	7/8	7/8	7/8	7/8	7/8	90,000
2 1/8	2 1/8	2 1/8	1 5/8	1 5/8	2 1/8	2 1/8	2 1/8	2 5/8	1 5/8	2 1/8	2 1/8	2 1/8	2 5/8	2 5/8	5/8	5/8	5/8	7/8	7/8	7/8	7/8	7/8	7/8	7/8	7/8	120,000
2 1/8	2 5/8	2 5/8	1 5/8	2 1/8	2 1/8	2 1/8	2 5/8	2 5/8	2 1/8	2 1/8	2 1/8	2 5/8	2 5/8	2 5/8	5/8	7/8	7/8	7/8	7/8	7/8	7/8	7/8	7/8	7/8	7/8	150,000
2 1/8	2 5/8	2 5/8	1 5/8	2 1/8	2 1/8	2 5/8	2 5/8	2 5/8	2 1/8	2 1/8	2 5/8	2 5/8	2 5/8	3 1/8	5/8	7/8	7/8	7/8	7/8	7/8	7/8	7/8	1 1/8	1 1/8	1 1/8	180,000
2 5/8	2 5/8	2 5/8	2 1/8	2 1/8	2 5/8	2 5/8	2 5/8	2 5/8	2 1/8	2 5/8	2 5/8	2 5/8	2 5/8	3 1/8	7/8	7/8	7/8	7/8	7/8	7/8	7/8	7/8	1 1/8	1 1/8	1 1/8	210,000
2 5/8	2 5/8	3 1/8	2 1/8	2 1/8	2 5/8	2 5/8	2 5/8	3 1/8	2 1/8	2 5/8	2 5/8	2 5/8	3 1/8	3 1/8	7/8	7/8	7/8	7/8	7/8	7/8	1 1/8	1 1/8	1 1/8	1 1/8	1 1/8	240,000
2 5/8	3 1/8	3 1/8	2 1/8	2 5/8	2 5/8	2 5/8	3 1/8	3 1/8	2 1/8	2 5/8	3 1/8	3 1/8	3 1/8	3 5/8	7/8	7/8	1 1/8	1 1/8	1 1/8	1 1/8	1 1/8	1 1/8	1 1/8	1 1/8	1 1/8	300,000
3 1/8	3 1/8	3 1/8	2 1/8	2 5/8	2 5/8	3 1/8	3 1/8	3 5/8	2 5/8	2 5/8	3 1/8	3 1/8	3 5/8	3 5/8	7/8	7/8	1 1/8	1 1/8	1 1/8	1 1/8	1 1/8	1 1/8	1 1/8	1 1/8	1 1/8	360,000
3 1/8	3 5/8	3 5/8	2 5/8	3 1/8	3 1/8	3 1/8	3 5/8	3 5/8	2 5/8	3 1/8	3 5/8	3 5/8	3 5/8	4 1/8	1 1/8	1 1/8	1 1/8	1 1/8	1 1/8	1 3/8	1 3/8	1 3/8	1 3/8	1 3/8	1 3/8	480,000
3 5/8	3 5/8	4 1/8	2 5/8	3 1/8	3 1/8	3 5/8	3 5/8	4 1/8	3 1/8	3 1/8	3 5/8	3 5/8	4 1/8	4 1/8	1 1/8	1 1/8	1 1/8	1 3/8	1 3/8	1 3/8	1 3/8	1 3/8	1 3/8	1 3/8	1 3/8	600,000

* Sizes that are highlighted indicate maximum suction line sizes that should be used for risers. Riser size should not exceed horizontal size. Properly placed suction traps must also be used for adequate oil return.
 All sizes shown are for O.D. Type L copper tubing.
 # Suction line sizes selected at pressure drop equivalent to 2°F. reduce estimate of system capacity accordingly.
 If system load drops below 40% of design, consideration to installing double suction risers should be made.

Table 12A. Recommended Line Sizes for R-502 *#

SYSTEM CAPACITY BTU/H	SUCTION LINE SIZE																				
	SUCTION TEMPERATURE																				
	+20°F						+10°F						-10°F						-20°F		
	Equivalent Lengths						Equivalent Lengths						Equivalent Lengths						Equivalent		
25'	50'	75'	100'	150'	200'	25'	50'	75'	100'	150'	200'	25'	50'	75'	100'	150'	200'	25'	50'	75'	
1,000	3/8	3/8	3/8	3/8	3/8	3/8	3/8	3/8	3/8	3/8	1/2	3/8	3/8	3/8	1/2	1/2	1/2	3/8	3/8	1/2	
3,000	3/8	1/2	1/2	1/2	5/8	1/2	1/2	5/8	5/8	5/8	5/8	1/2	1/2	5/8	5/8	7/8	7/8	1/2	5/8	5/8	
4,000	1/2	1/2	5/8	5/8	5/8	1/2	1/2	5/8	5/8	5/8	7/8	1/2	5/8	5/8	7/8	7/8	7/8	5/8	7/8	7/8	
6,000	1/2	5/8	5/8	7/8	7/8	1/2	5/8	5/8	7/8	7/8	7/8	5/8	7/8	7/8	7/8	7/8	7/8	7/8	7/8	7/8	
9,000	5/8	5/8	7/8	7/8	7/8	5/8	7/8	7/8	7/8	7/8	7/8	7/8	7/8	7/8	7/8	7/8	1 1/8	7/8	7/8	7/8	
12,000	5/8	7/8	7/8	7/8	7/8	5/8	7/8	7/8	7/8	7/8	1 1/8	7/8	7/8	7/8	1 1/8	1 1/8	1 1/8	7/8	1 1/8	1 1/8	
15,000	5/8	7/8	7/8	7/8	1 1/8	7/8	7/8	7/8	7/8	1 1/8	1 1/8	7/8	7/8	1 1/8	1 1/8	1 1/8	1 1/8	1 1/8	1 1/8	1 1/8	
18,000	7/8	7/8	7/8	7/8	1 1/8	1 1/8	7/8	7/8	7/8	1 1/8	1 1/8	7/8	7/8	1 1/8	1 1/8	1 1/8	1 3/8	1 1/8	1 1/8	1 1/8	
24,000	7/8	7/8	1 1/8	1 1/8	1 1/8	7/8	1 1/8	1 1/8	1 1/8	1 1/8	1 3/8	7/8	1 1/8	1 1/8	1 1/8	1 3/8	1 3/8	1 1/8	1 3/8	1 3/8	
30,000	7/8	1 1/8	1 1/8	1 1/8	1 3/8	7/8	1 1/8	1 1/8	1 1/8	1 3/8	1 3/8	1 1/8	1 1/8	1 3/8	1 3/8	1 3/8	1 5/8	1 1/8	1 3/8	1 5/8	
36,000	7/8	1 1/8	1 1/8	1 1/8	1 3/8	1 1/8	1 1/8	1 1/8	1 3/8	1 3/8	1 3/8	1 1/8	1 3/8	1 3/8	1 3/8	1 5/8	1 5/8	1 3/8	1 5/8	1 5/8	
42,000	1 1/8	1 1/8	1 1/8	1 3/8	1 3/8	1 1/8	1 1/8	1 3/8	1 3/8	1 3/8	1 5/8	1 1/8	1 3/8	1 3/8	1 5/8	1 5/8	1 5/8	1 3/8	1 3/8	1 5/8	
48,000	1 1/8	1 1/8	1 3/8	1 3/8	1 5/8	1 1/8	1 1/8	1 3/8	1 3/8	1 5/8	1 5/8	1 1/8	1 3/8	1 5/8	1 5/8	1 5/8	2 1/8	1 3/8	1 5/8	1 5/8	
54,000	1 1/8	1 1/8	1 3/8	1 3/8	1 5/8	1 1/8	1 3/8	1 3/8	1 3/8	1 5/8	1 5/8	1 3/8	1 3/8	1 5/8	1 5/8	2 1/8	2 1/8	1 3/8	1 5/8	1 5/8	
60,000	1 1/8	1 1/8	1 3/8	1 3/8	1 5/8	1 1/8	1 3/8	1 3/8	1 5/8	1 5/8	1 5/8	1 3/8	1 3/8	1 5/8	1 5/8	2 1/8	2 1/8	1 5/8	1 5/8	1 5/8	
66,000	1 1/8	1 3/8	1 3/8	1 3/8	1 5/8	1 1/8	1 3/8	1 3/8	1 5/8	1 5/8	2 1/8	1 3/8	1 5/8	1 5/8	2 1/8	2 1/8	2 1/8	1 5/8	1 5/8	2 1/8	
72,000	1 1/8	1 3/8	1 3/8	1 5/8	1 5/8	1 1/8	1 3/8	1 5/8	1 5/8	1 5/8	2 1/8	1 3/8	1 5/8	1 5/8	2 1/8	2 1/8	1 5/8	1 5/8	2 1/8	2 1/8	
78,000	1 1/8	1 3/8	1 3/8	1 5/8	1 5/8	1 3/8	1 3/8	1 5/8	1 5/8	2 1/8	2 1/8	1 3/8	1 5/8	2 1/8	2 1/8	2 1/8	2 1/8	1 5/8	1 5/8	2 1/8	
84,000	1 1/8	1 3/8	1 5/8	1 5/8	2 1/8	1 3/8	1 3/8	1 5/8	1 5/8	2 1/8	2 1/8	1 3/8	1 5/8	2 1/8	2 1/8	2 1/8	2 1/8	1 5/8	2 1/8	2 1/8	
90,000	1 3/8	1 3/8	1 5/8	1 5/8	2 1/8	1 3/8	1 5/8	1 5/8	1 5/8	2 1/8	2 1/8	1 5/8	1 5/8	2 1/8	2 1/8	2 5/8	1 5/8	2 1/8	2 1/8	2 1/8	
120,000	1 3/8	1 5/8	1 5/8	2 1/8	2 1/8	1 3/8	1 5/8	2 1/8	2 1/8	2 1/8	2 1/8	1 5/8	2 1/8	2 1/8	2 5/8	2 5/8	2 1/8	2 1/8	2 1/8	2 1/8	
150,000	1 5/8	1 5/8	2 1/8	2 1/8	2 1/8	1 5/8	2 1/8	2 1/8	2 1/8	2 5/8	2 5/8	2 1/8	2 1/8	2 1/8	2 5/8	2 5/8	2 1/8	2 1/8	2 5/8	2 5/8	
180,000	1 5/8	2 1/8	2 1/8	2 1/8	2 5/8	1 5/8	2 1/8	2 1/8	2 1/8	2 5/8	2 5/8	2 1/8	2 1/8	2 5/8	2 5/8	3 1/8	2 1/8	2 5/8	2 5/8	2 5/8	
210,000	1 5/8	2 1/8	2 1/8	2 1/8	2 5/8	2 1/8	2 1/8	2 1/8	2 5/8	2 5/8	2 5/8	2 1/8	2 5/8	2 5/8	3 1/8	3 1/8	2 1/8	2 5/8	2 5/8	2 5/8	
240,000	1 5/8	2 1/8	2 1/8	2 1/8	2 5/8	2 1/8	2 1/8	2 5/8	2 5/8	2 5/8	2 5/8	2 1/8	2 5/8	2 5/8	3 1/8	3 1/8	2 5/8	2 5/8	2 5/8	2 5/8	
300,000	2 1/8	2 1/8	2 5/8	2 5/8	3 1/8	2 1/8	2 5/8	2 5/8	2 5/8	3 1/8	3 1/8	2 5/8	2 5/8	3 1/8	3 1/8	3 5/8	2 5/8	3 1/8	3 1/8	3 1/8	
360,000	2 1/8	2 1/8	2 5/8	2 5/8	3 1/8	2 1/8	2 5/8	2 5/8	2 5/8	3 1/8	3 1/8	2 5/8	2 5/8	3 1/8	3 1/8	3 5/8	2 5/8	3 1/8	3 1/8	3 1/8	
480,000	2 1/8	2 5/8	2 5/8	3 1/8	3 5/8	2 5/8	2 5/8	3 1/8	3 1/8	3 5/8	3 5/8	2 5/8	3 1/8	3 5/8	3 5/8	4 1/8	3 1/8	3 1/8	3 1/8	3 5/8	
600,000	2 5/8	2 5/8	3 1/8	3 1/8	3 5/8	2 5/8	3 1/8	3 1/8	3 1/8	3 5/8	3 5/8	3 1/8	3 5/8	3 5/8	4 1/8	4 1/8	5 1/8	3 1/8	3 5/8	3 5/8	

* Sizes that are highlighted indicate maximum suction line sizes that should be used for risers. Riser size should not exceed horizontal size. Properly placed suction traps must also be used for adequate oil return.
 All sizes shown are for O.D. Type L copper tubing.
 # Suction line sizes selected at pressure drop equivalent to 2'F. reduce estimate of system capacity accordingly.
 If system load drops below 40% of design, consideration to installing double suction risers should be made.

Table 12B. Recommended Line Sizes for R-502 (continued) *#

SUCTION LINE SIZE														LIQUID LINE SIZE						SYSTEM CAPACITY BTU/H	
SUCTION TEMPERATURE														Receiver to Expansion Valve Equivalent Lengths							
-20°F Lengths			-30°F Equivalent Lengths						-40°F Equivalent Lengths												
100'	150'	200'	25'	50'	75'	100'	150'	200'	25'	50'	75'	100'	150'	200'	25'	50'	75'	100'	150'		200'
1/2	1/2	1/2	3/8	1/2	1/2	1/2	5/8	5/8	1/2	1/2	1/2	1/2	5/8	7/8	3/8	3/8	3/8	3/8	3/8	3/8	1,000
7/8	7/8	7/8	5/8	7/8	7/8	7/8	7/8	7/8	7/8	7/8	7/8	7/8	7/8	7/8	3/8	3/8	3/8	3/8	3/8	3/8	3,000
7/8	7/8	1 1/8	5/8	7/8	7/8	7/8	7/8	7/8	7/8	7/8	7/8	7/8	7/8	1 1/8	3/8	3/8	3/8	3/8	3/8	1/2	4,000
7/8	1 1/8	1 1/8	5/8	7/8	7/8	7/8	1 1/8	1 1/8	7/8	7/8	7/8	1 1/8	1 1/8	1 1/8	3/8	3/8	3/8	3/8	3/8	1/2	6,000
1 1/8	1 1/8	1 1/8	7/8	1 1/8	1 1/8	1 1/8	1 1/8	1 1/8	7/8	1 1/8	1 1/8	1 1/8	1 1/8	1 3/8	3/8	3/8	3/8	3/8	3/8	1/2	9,000
1 1/8	1 1/8	1 3/8	7/8	1 1/8	1 1/8	1 1/8	1 1/8	1 3/8	1 1/8	1 1/8	1 1/8	1 3/8	1 3/8	1 3/8	3/8	3/8	3/8	1/2	1/2	1/2	12,000
1 1/8	1 1/8	1 3/8	1 1/8	1 1/8	1 1/8	1 1/8	1 3/8	1 3/8	1 1/8	1 1/8	1 3/8	1 3/8	1 3/8	1 5/8	3/8	3/8	1/2	1/2	1/2	1/2	15,000
1 3/8	1 3/8	1 3/8	1 1/8	1 1/8	1 3/8	1 3/8	1 3/8	1 3/8	1 1/8	1 3/8	1 3/8	1 3/8	1 5/8	1 5/8	3/8	1/2	1/2	1/2	1/2	5/8	18,000
1 3/8	1 3/8	1 5/8	1 1/8	1 3/8	1 3/8	1 3/8	1 5/8	1 5/8	1 1/8	1 3/8	1 3/8	1 5/8	1 5/8	2 1/8	1/2	1/2	1/2	1/2	5/8	5/8	24,000
1 5/8	1 5/8	1 5/8	1 1/8	1 3/8	1 5/8	1 5/8	1 5/8	2 1/8	1 3/8	1 5/8	1 5/8	1 5/8	2 1/8	2 1/8	1/2	1/2	5/8	5/8	5/8	5/8	30,000
1 5/8	1 5/8	2 1/8	1 3/8	1 3/8	1 5/8	1 5/8	2 1/8	2 1/8	1 3/8	1 5/8	1 5/8	2 1/8	2 1/8	2 1/8	1/2	1/2	5/8	5/8	5/8	7/8	36,000
1 5/8	2 1/8	2 1/8	1 3/8	1 5/8	1 5/8	2 1/8	2 1/8	2 1/8	1 3/8	1 5/8	2 1/8	2 1/8	2 1/8	2 1/8	1/2	5/8	5/8	5/8	7/8	7/8	42,000
2 1/8	2 1/8	2 1/8	1 3/8	1 5/8	2 1/8	2 1/8	2 1/8	2 1/8	1 5/8	2 1/8	2 1/8	2 1/8	2 1/8	2 5/8	1/2	5/8	5/8	7/8	7/8	7/8	48,000
2 1/8	2 1/8	2 1/8	1 3/8	1 5/8	2 1/8	2 1/8	2 1/8	2 1/8	1 5/8	2 1/8	2 1/8	2 1/8	2 5/8	2 5/8	1/2	5/8	5/8	7/8	7/8	7/8	54,000
2 1/8	2 1/8	2 1/8	1 5/8	1 5/8	2 1/8	2 1/8	2 1/8	2 1/8	1 5/8	2 1/8	2 1/8	2 1/8	2 5/8	2 5/8	5/8	5/8	7/8	7/8	7/8	7/8	60,000
2 1/8	2 1/8	2 1/8	1 5/8	2 1/8	2 1/8	2 1/8	2 1/8	2 5/8	2 1/8	2 1/8	2 1/8	2 1/8	2 5/8	2 5/8	5/8	5/8	7/8	7/8	7/8	7/8	66,000
2 1/8	2 1/8	2 1/8	1 5/8	2 1/8	2 1/8	2 1/8	2 5/8	2 5/8	2 1/8	2 1/8	2 1/8	2 5/8	2 5/8	2 5/8	5/8	7/8	7/8	7/8	7/8	7/8	72,000
2 1/8	2 1/8	2 1/8	1 5/8	2 1/8	2 1/8	2 1/8	2 5/8	2 5/8	2 1/8	2 1/8	2 1/8	2 5/8	2 5/8	2 5/8	5/8	7/8	7/8	7/8	7/8	7/8	78,000
2 1/8	2 1/8	2 5/8	1 5/8	2 1/8	2 1/8	2 1/8	2 5/8	2 5/8	2 1/8	2 1/8	2 5/8	2 5/8	2 5/8	3 1/8	5/8	7/8	7/8	7/8	7/8	7/8	84,000
2 1/8	2 5/8	2 5/8	2 1/8	2 1/8	2 1/8	2 5/8	2 5/8	2 5/8	2 1/8	2 1/8	2 5/8	2 5/8	2 5/8	3 1/8	5/8	7/8	7/8	7/8	7/8	1 1/8	90,000
2 5/8	2 5/8	2 5/8	2 1/8	2 1/8	2 5/8	2 5/8	2 5/8	3 1/8	2 1/8	2 5/8	2 5/8	3 1/8	3 1/8	3 1/8	7/8	7/8	7/8	7/8	1 1/8	1 1/8	120,000
2 5/8	2 5/8	3 1/8	2 1/8	2 5/8	2 5/8	2 5/8	3 1/8	3 1/8	2 5/8	2 5/8	3 1/8	3 1/8	3 1/8	3 5/8	7/8	7/8	7/8	1 1/8	1 1/8	1 1/8	150,000
2 5/8	3 1/8	3 1/8	2 1/8	2 5/8	3 1/8	3 1/8	3 1/8	3 5/8	2 5/8	3 1/8	3 1/8	3 1/8	3 5/8	3 5/8	7/8	7/8	1 1/8	1 1/8	1 1/8	1 1/8	180,000
3 1/8	3 1/8	3 5/8	2 5/8	2 5/8	3 1/8	3 1/8	3 5/8	3 5/8	2 5/8	3 1/8	3 1/8	3 5/8	3 5/8	4 1/8	7/8	1 1/8	1 1/8	1 1/8	1 1/8	1 3/8	210,000
3 1/8	3 5/8	3 5/8	2 5/8	3 1/8	3 1/8	3 5/8	3 5/8	3 5/8	2 5/8	3 1/8	3 1/8	3 5/8	4 1/8	4 1/8	7/8	1 1/8	1 1/8	1 1/8	1 3/8	1 3/8	240,000
3 5/8	3 5/8	3 5/8	2 5/8	3 1/8	3 5/8	3 5/8	4 1/8	4 1/8	3 1/8	3 5/8	3 5/8	4 1/8	4 1/8	5 1/8	1 1/8	1 1/8	1 1/8	1 3/8	1 3/8	1 3/8	300,000
3 5/8	4 1/8	4 1/8	3 1/8	3 1/8	3 5/8	3 5/8	4 1/8	4 1/8	3 1/8	3 5/8	3 5/8	4 1/8	5 1/8	5 1/8	1 1/8	1 1/8	1 3/8	1 3/8	1 3/8	1 5/8	360,000
3 5/8	4 1/8	4 1/8	3 1/8	3 5/8	4 1/8	4 1/8	4 1/8	5 1/8	5 1/8	3 5/8	4 1/8	4 1/8	5 1/8	5 1/8	6 1/8	1 1/8	1 3/8	1 3/8	1 5/8	1 5/8	480,000
4 1/8	4 1/8	5 1/8	3 5/8	4 1/8	4 1/8	5 1/8	5 1/8	5 1/8	3 5/8	4 1/8	5 1/8	5 1/8	5 1/8	6 1/8	1 1/8	1 3/8	1 5/8	1 5/8	1 5/8	2 1/8	600,000

* Sizes that are highlighted indicate maximum suction line sizes that should be used for risers. Riser size should not exceed horizontal size. Properly placed suction traps must also be used for adequate oil return.
 All sizes shown are for O.D. Type L copper tubing.
 # Suction line sizes selected at pressure drop equivalent to 2°F. reduce estimate of system capacity accordingly.
 If system load drops below 40% of design, consideration to installing double suction risers should be made.

Table 13A. Recommended Line Sizes for R-404A and R507 *#

SYSTEM CAPACITY BTU/H	SUCTION LINE SIZE																				
	SUCTION TEMPERATURE																				
	+20°F						+10°F						-10°F						-20°F		
	Equivalent Lengths						Equivalent Lengths						Equivalent Lengths						Equivalent		
	25'	50'	75'	100'	150'	200'	25'	50'	75'	100'	150'	200'	25'	50'	75'	100'	150'	200'	25'	50'	75'
1,000	3/8	3/8	3/8	3/8	3/8	3/8	3/8	3/8	3/8	3/8	3/8	1/2	3/8	3/8	3/8	1/2	1/2	1/2	3/8	3/8	1/2
3,000	3/8	3/8	1/2	1/2	1/2	5/8	3/8	1/2	1/2	1/2	5/8	5/8	1/2	1/2	5/8	5/8	5/8	7/8	1/2	1/2	5/8
4,000	3/8	1/2	1/2	1/2	5/8	5/8	1/2	1/2	1/2	5/8	5/8	7/8	1/2	5/8	5/8	5/8	7/8	7/8	1/2	5/8	5/8
6,000	1/2	1/2	5/8	5/8	7/8	7/8	1/2	1/2	5/8	5/8	7/8	7/8	1/2	5/8	5/8	7/8	7/8	7/8	5/8	5/8	7/8
9,000	5/8	5/8	7/8	7/8	7/8	7/8	5/8	5/8	7/8	7/8	7/8	7/8	5/8	7/8	7/8	7/8	7/8	1 1/8	5/8	7/8	7/8
12,000	5/8	7/8	7/8	7/8	7/8	7/8	5/8	7/8	7/8	7/8	7/8	1 1/8	7/8	7/8	7/8	7/8	1 1/8	1 1/8	7/8	7/8	7/8
15,000	5/8	7/8	7/8	7/8	7/8	1 1/8	7/8	7/8	7/8	7/8	1 1/8	1 1/8	7/8	7/8	7/8	1 1/8	1 1/8	1 1/8	7/8	7/8	1 1/8
18,000	7/8	7/8	7/8	7/8	1 1/8	1 1/8	7/8	7/8	7/8	1 1/8	1 1/8	1 1/8	7/8	7/8	1 1/8	1 1/8	1 1/8	1 3/8	7/8	1 1/8	1 1/8
24,000	7/8	7/8	7/8	1 1/8	1 1/8	1 1/8	7/8	1 1/8	1 1/8	1 1/8	1 1/8	1 3/8	7/8	1 1/8	1 1/8	1 1/8	1 3/8	1 3/8	1 1/8	1 1/8	1 1/8
30,000	7/8	7/8	1 1/8	1 1/8	1 1/8	1 3/8	7/8	1 1/8	1 1/8	1 1/8	1 3/8	1 3/8	1 1/8	1 1/8	1 1/8	1 3/8	1 3/8	1 3/8	1 1/8	1 1/8	1 1/8
36,000	7/8	1 1/8	1 1/8	1 1/8	1 3/8	1 3/8	1 1/8	1 1/8	1 1/8	1 3/8	1 3/8	1 3/8	1 1/8	1 1/8	1 3/8	1 3/8	1 3/8	1 5/8	1 1/8	1 1/8	1 3/8
42,000	1 1/8	1 1/8	1 1/8	1 3/8	1 3/8	1 3/8	1 1/8	1 1/8	1 3/8	1 3/8	1 3/8	1 5/8	1 1/8	1 3/8	1 3/8	1 3/8	1 5/8	1 5/8	1 1/8	1 3/8	1 3/8
48,000	1 1/8	1 1/8	1 3/8	1 3/8	1 3/8	1 3/8	1 1/8	1 1/8	1 3/8	1 3/8	1 5/8	1 5/8	1 1/8	1 3/8	1 3/8	1 3/8	1 5/8	1 5/8	1 1/8	1 3/8	1 3/8
54,000	1 1/8	1 1/8	1 3/8	1 3/8	1 3/8	1 5/8	1 1/8	1 3/8	1 3/8	1 3/8	1 5/8	1 5/8	1 3/8	1 3/8	1 3/8	1 5/8	1 5/8	1 5/8	1 3/8	1 3/8	1 5/8
60,000	1 1/8	1 1/8	1 3/8	1 3/8	1 5/8	1 5/8	1 1/8	1 3/8	1 3/8	1 5/8	1 5/8	1 5/8	1 3/8	1 3/8	1 5/8	1 5/8	1 5/8	2 1/8	1 3/8	1 3/8	1 5/8
66,000	1 1/8	1 3/8	1 3/8	1 3/8	1 5/8	1 5/8	1 1/8	1 3/8	1 3/8	1 5/8	1 5/8	1 5/8	1 3/8	1 5/8	1 5/8	1 5/8	1 5/8	1 5/8	1 3/8	1 5/8	1 5/8
72,000	1 1/8	1 3/8	1 3/8	1 5/8	1 5/8	1 5/8	1 1/8	1 3/8	1 5/8	1 5/8	1 5/8	1 5/8	1 3/8	1 5/8	1 5/8	1 5/8	1 5/8	1 5/8	1 3/8	1 5/8	1 5/8
78,000	1 1/8	1 3/8	1 3/8	1 5/8	1 5/8	2 1/8	1 3/8	1 3/8	1 5/8	1 5/8	1 5/8	2 1/8	1 3/8	1 5/8	1 5/8	1 5/8	1 5/8	2 1/8	1 5/8	1 5/8	1 5/8
84,000	1 1/8	1 3/8	1 5/8	1 5/8	1 5/8	2 1/8	1 3/8	1 3/8	1 5/8	1 5/8	2 1/8	2 1/8	1 3/8	1 5/8	1 5/8	1 5/8	2 1/8	2 1/8	1 5/8	1 5/8	1 5/8
90,000	1 3/8	1 3/8	1 5/8	1 5/8	2 1/8	2 1/8	1 3/8	1 5/8	1 5/8	1 5/8	2 1/8	2 1/8	1 5/8	1 5/8	1 5/8	2 1/8	2 1/8	2 5/8	1 5/8	1 5/8	2 1/8
120,000	1 3/8	1 5/8	1 5/8	2 1/8	2 1/8	2 1/8	1 3/8	1 5/8	2 1/8	2 1/8	2 1/8	2 1/8	1 5/8	2 1/8	2 1/8	2 1/8	2 5/8	2 5/8	1 5/8	2 1/8	2 1/8
150,000	1 5/8	1 5/8	2 1/8	2 1/8	2 1/8	2 1/8	1 5/8	2 1/8	2 1/8	2 1/8	2 1/8	2 5/8	2 1/8	2 1/8	2 1/8	2 5/8	2 5/8	2 5/8	2 1/8	2 1/8	2 1/8
180,000	1 5/8	2 1/8	2 1/8	2 1/8	2 1/8	2 5/8	1 5/8	2 1/8	2 1/8	2 1/8	2 5/8	2 5/8	2 1/8	2 1/8	2 5/8	2 5/8	2 5/8	3 1/8	2 1/8	2 1/8	2 5/8
210,000	1 5/8	2 1/8	2 1/8	2 1/8	2 5/8	2 5/8	2 1/8	2 1/8	2 1/8	2 5/8	2 5/8	2 5/8	2 1/8	2 1/8	2 5/8	2 5/8	3 1/8	3 1/8	2 1/8	2 5/8	2 5/8
240,000	1 5/8	2 1/8	2 1/8	2 1/8	2 5/8	2 5/8	2 1/8	2 1/8	2 5/8	2 5/8	2 5/8	2 5/8	2 1/8	2 5/8	2 5/8	2 5/8	3 1/8	3 1/8	2 1/8	2 5/8	2 5/8
300,000	2 1/8	2 1/8	2 5/8	2 5/8	2 5/8	3 1/8	2 1/8	2 5/8	2 5/8	2 5/8	3 1/8	3 1/8	2 5/8	2 5/8	2 5/8	3 1/8	3 1/8	3 5/8	2 5/8	2 5/8	2 5/8
360,000	2 1/8	2 1/8	2 5/8	2 5/8	3 1/8	3 1/8	2 1/8	2 5/8	2 5/8	2 5/8	3 1/8	3 1/8	2 5/8	2 5/8	3 1/8	3 1/8	3 5/8	3 5/8	2 5/8	2 5/8	3 1/8
480,000	2 1/8	2 5/8	2 5/8	3 1/8	3 1/8	3 5/8	2 5/8	2 5/8	2 5/8	2 5/8	3 5/8	3 5/8	2 5/8	3 1/8	3 1/8	3 5/8	3 5/8	4 1/8	2 5/8	3 1/8	3 1/8
600,000	2 5/8	2 5/8	3 1/8	3 1/8	3 5/8	3 5/8	2 5/8	2 5/8	3 1/8	3 1/8	3 5/8	3 5/8	3 1/8	3 1/8	3 1/8	3 5/8	4 1/8	4 1/8	3 1/8	3 1/8	3 1/8

* Sizes that are highlighted indicate maximum suction line sizes that should be used for risers. Riser size should not exceed horizontal size. Properly placed suction traps must also be used for adequate oil return.

All sizes shown are for O.D. Type L copper tubing.

Suction line sizes selected at pressure drop equivalent to 2°F. reduce estimate of system capacity accordingly.

If system load drops below 40% of design, consideration to installing double suction risers should be made.

Table 13B. Recommended Line Sizes for R-404A and R507 (continued) *#

SUCTION LINE SIZE															LIQUID LINE SIZE						SYSTEM CAPACITY BTU/H
SUCTION TEMPERATURE															Receiver to Expansion Valve Equivalent Lengths						
-20°F Lengths			-30°F Equivalent Lengths						-40°F Equivalent Lengths												
100'	150'	200'	25'	50'	75'	100'	150'	200'	25'	50'	75'	100'	150'	200'	25'	50'	75'	100'	150'	200'	
1/2	1/2	1/2	3/8	3/8	1/2	1/2	1/2	5/8	3/8	1/2	1/2	1/2	5/8	5/8	3/8	3/8	3/8	3/8	3/8	3/8	1,000
5/8	7/8	7/8	1/2	1/2	5/8	5/8	7/8	7/8	1/2	1/2	5/8	5/8	7/8	7/8	3/8	3/8	3/8	3/8	3/8	3/8	3,000
7/8	7/8	7/8	5/8	5/8	5/8	7/8	7/8	7/8	1/2	5/8	5/8	7/8	7/8	7/8	3/8	3/8	3/8	3/8	3/8	3/8	4,000
7/8	7/8	7/8	5/8	5/8	7/8	7/8	7/8	7/8	5/8	5/8	7/8	7/8	7/8	11/8	3/8	3/8	3/8	3/8	3/8	3/8	6,000
7/8	1 1/8	1 1/8	5/8	7/8	7/8	7/8	1 1/8	1 1/8	5/8	7/8	7/8	7/8	1 1/8	1 1/8	3/8	3/8	3/8	3/8	3/8	3/8	9,000
1 1/8	1 1/8	1 1/8	7/8	7/8	7/8	1 1/8	1 1/8	1 1/8	7/8	7/8	7/8	1 1/8	1 1/8	1 1/8	3/8	3/8	3/8	3/8	3/8	1/2	12,000
1 1/8	1 1/8	1 3/8	7/8	7/8	1 1/8	1 1/8	1 1/8	1 3/8	7/8	7/8	1 1/8	1 1/8	1 1/8	1 3/8	3/8	3/8	3/8	3/8	1/2	1/2	15,000
1 1/8	1 3/8	1 3/8	7/8	1 1/8	1 1/8	1 1/8	1 3/8	1 3/8	7/8	1 1/8	1 1/8	1 1/8	1 3/8	1 3/8	3/8	3/8	3/8	1/2	1/2	1/2	18,000
1 3/8	1 3/8	1 5/8	1 1/8	1 1/8	1 1/8	1 3/8	1 3/8	1 3/8	1 1/8	1 1/8	1 1/8	1 3/8	1 3/8	1 3/8	3/8	3/8	1/2	1/2	1/2	1/2	24,000
1 3/8	1 3/8	1 5/8	1 1/8	1 1/8	1 3/8	1 3/8	1 3/8	1 5/8	1 1/8	1 1/8	1 3/8	1 3/8	1 3/8	1 5/8	3/8	1/2	1/2	1/2	1/2	1/2	30,000
1 3/8	1 5/8	1 5/8	1 1/8	1 3/8	1 3/8	1 3/8	1 3/8	1 5/8	1 1/8	1 3/8	1 3/8	1 3/8	1 5/8	1 5/8	1/2	1/2	1/2	1/2	1/2	5/8	36,000
1 5/8	1 5/8	1 5/8	1 1/8	1 3/8	1 3/8	1 3/8	1 5/8	1 5/8	1 1/8	1 3/8	1 3/8	1 3/8	1 5/8	1 5/8	1/2	1/2	1/2	1/2	5/8	5/8	42,000
1 5/8	1 5/8	1 5/8	1 1/8	1 3/8	1 3/8	1 3/8	1 5/8	1 5/8	1 1/8	1 3/8	1 3/8	1 3/8	1 5/8	1 5/8	1/2	1/2	1/2	5/8	5/8	5/8	48,000
1 5/8	1 5/8	1 5/8	1 3/8	1 3/8	1 3/8	1 5/8	1 5/8	2 1/8	1 3/8	1 3/8	1 3/8	1 5/8	1 5/8	2 1/8	1/2	1/2	1/2	5/8	5/8	5/8	54,000
1 5/8	1 5/8	2 1/8	1 3/8	1 3/8	1 5/8	1 5/8	1 5/8	2 1/8	1 3/8	1 3/8	1 5/8	1 5/8	1 5/8	2 1/8	1/2	1/2	5/8	5/8	5/8	5/8	60,000
1 5/8	1 5/8	2 1/8	1 3/8	1 5/8	1 5/8	1 5/8	1 5/8	2 1/8	1 3/8	1 5/8	1 5/8	1 5/8	1 5/8	2 1/8	1/2	1/2	5/8	5/8	5/8	5/8	66,000
1 5/8	1 5/8	2 1/8	1 3/8	1 5/8	1 5/8	1 5/8	1 5/8	2 1/8	1 3/8	1 5/8	1 5/8	1 5/8	1 5/8	2 1/8	1/2	5/8	5/8	5/8	5/8	5/8	72,000
1 5/8	2 1/8	2 1/8	1 5/8	1 5/8	1 5/8	1 5/8	2 1/8	2 1/8	1 5/8	1 5/8	1 5/8	1 5/8	2 1/8	2 1/8	5/8	5/8	5/8	5/8	5/8	7/8	78,000
2 1/8	2 1/8	2 1/8	1 5/8	1 5/8	1 5/8	2 1/8	2 1/8	2 1/8	1 5/8	1 5/8	1 5/8	2 1/8	2 1/8	2 1/8	5/8	5/8	5/8	5/8	7/8	7/8	84,000
2 1/8	2 1/8	2 5/8	1 5/8	2 1/8	2 1/8	2 1/8	2 1/8	2 5/8	1 5/8	1 5/8	2 1/8	2 1/8	2 1/8	2 5/8	5/8	5/8	5/8	7/8	7/8	7/8	90,000
2 1/8	2 5/8	2 5/8	1 5/8	2 1/8	2 1/8	2 1/8	2 5/8	2 5/8	1 5/8	2 1/8	2 1/8	2 1/8	2 5/8	2 5/8	5/8	5/8	7/8	7/8	7/8	7/8	120,000
2 5/8	2 5/8	2 5/8	2 1/8	2 1/8	2 1/8	2 5/8	2 5/8	2 5/8	2 1/8	2 1/8	2 5/8	2 5/8	2 5/8	2 5/8	5/8	7/8	7/8	7/8	7/8	1 1/8	150,000
2 5/8	2 5/8	3 1/8	2 1/8	2 1/8	2 5/8	2 5/8	2 5/8	3 1/8	2 1/8	2 1/8	2 5/8	2 5/8	2 5/8	3 1/8	7/8	7/8	7/8	7/8	1 1/8	1 1/8	180,000
2 5/8	3 1/8	3 1/8	2 1/8	2 5/8	2 5/8	2 5/8	3 1/8	3 1/8	2 1/8	2 5/8	2 5/8	2 5/8	3 1/8	3 1/8	7/8	7/8	7/8	1 1/8	1 1/8	1 1/8	210,000
2 5/8	3 1/8	3 1/8	2 5/8	2 5/8	2 5/8	3 1/8	3 1/8	3 5/8	2 5/8	2 5/8	2 5/8	3 1/8	3 1/8	3 5/8	7/8	7/8	1 1/8	1 1/8	1 1/8	1 3/8	240,000
3 1/8	3 5/8	3 5/8	2 5/8	2 5/8	3 1/8	3 1/8	3 5/8	4 1/8	2 5/8	2 5/8	3 1/8	3 5/8	3 5/8	4 1/8	7/8	1 1/8	1 1/8	1 1/8	1 3/8	1 3/8	300,000
3 5/8	3 5/8	4 1/8	2 5/8	3 1/8	3 1/8	3 5/8	3 5/8	4 1/8	2 5/8	3 1/8	3 5/8	3 5/8	4 1/8	4 1/8	1 1/8	1 1/8	1 1/8	1 3/8	1 3/8	1 5/8	360,000
3 5/8	3 5/8	4 1/8	3 1/8	3 5/8	3 5/8	4 1/8	4 1/8	4 1/8	3 1/8	3 5/8	3 5/8	4 1/8	4 1/8	4 1/8	1 1/8	1 1/8	1 3/8	1 3/8	1 5/8	1 5/8	480,000
3 5/8	3 5/8	4 1/8	3 1/8	3 5/8	3 5/8	4 1/8	4 1/8	5 1/8	3 1/8	3 5/8	3 5/8	4 1/8	4 1/8	5 1/8	1 1/8	1 3/8	1 3/8	1 5/8	1 5/8	1 5/8	600,000

* Sizes that are highlighted indicate maximum suction line sizes that should be used for risers. Riser size should not exceed horizontal size. Properly placed suction traps must also be used for adequate oil return.
 All sizes shown are for O.D. Type L copper tubing.
 # Suction line sizes selected at pressure drop equivalent to 2'F. reduce estimate of system capacity accordingly.
 If system load drops below 40% of design, consideration to installing double suction risers should be made.

Refrigerant Piping

The system as supplied by *Heatcraft*, was thoroughly cleaned and dehydrated at the factory. Foreign matter may enter the system by way of the evaporator to condensing unit piping. Therefore, care must be used during installation of the piping to prevent entrance of foreign matter.

Install all refrigeration system components in accordance with applicable local and national codes and in conformance with good practice required for the proper operation of the system.

The refrigerant pipe size should be selected from the tables on pages 13-21. The interconnecting pipe size is not necessarily the same size as the stub-out on the condensing unit or the evaporator.

The following procedures should be followed:

- (a) Do not leave dehydrated compressors or filter-driers on condensing units open to the atmosphere any longer than is absolutely necessary.
- (b) Use only refrigeration grade copper tubing, properly sealed against contamination.
- (c) Suction lines should slope 1/4" per 10 feet towards the compressor.
- (d) Suitable P-type oil traps should be located at the base of each suction riser of four (4) feet or more to enhance oil return to the compressor.
- (e) For desired method of superheat measurement, a pressure tap should be installed in each evaporator suction line in the proximity of the expansion valve bulb.
- (f) **When brazing refrigerant lines, an inert gas should be passed through the line at low pressure to prevent scaling and oxidation inside the tubing. Dry nitrogen is preferred.**
- (g) Use only a suitable silver solder alloy on suction and liquid lines.
- (h) Limit the soldering paste or flux to the minimum required to prevent contamination of the solder joint internally. Flux only the male portion of the connection, never the female. After brazing, remove excess flux.
- (i) See Table 9 on page 13 for discharge and liquid drain line sizes for remote condenser connections.
- (j) If isolation valves are installed at the evaporator, full port ball valves should be used.

Figure 14. Example of Pipe Support

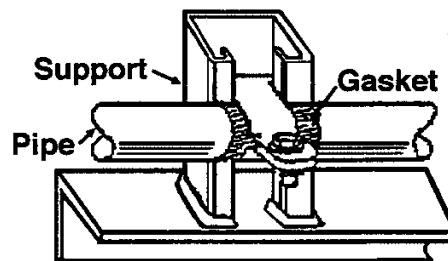

Refrigerant Pipe Support

1. Normally, any straight run of tubing must be supported in at least two locations near each end of the run. Long runs require additional supports. The refrigerant lines should be supported and fastened properly. As a guide, 3/8 to 7/8 should be supported every 5 feet; 1-1/8 and 1-3/8 every 7 feet; and 1-5/8 and 2-1/8 every 9 to 10 feet.
2. When changing directions in a run of tubing, no corner should be left unsupported. Supports should be placed a maximum of 2 feet in each direction from the corner.
3. Piping attached to a vibrating object (such as a compressor or compressor base) must be supported in such a manner that will not restrict the movement of the vibrating object. Rigid mounting will fatigue the copper tubing.
4. Do not use short radius ells. Short radius elbows have points of excessive stress concentration and are subject to breakage at these points.
5. Thoroughly inspect all piping after the equipment is in operation and add supports wherever line vibration is significantly greater than most of the other piping. Extra supports are relatively inexpensive as compared to refrigerant loss.

Figure 15. Condensing Unit/Compressor to Wall Support.

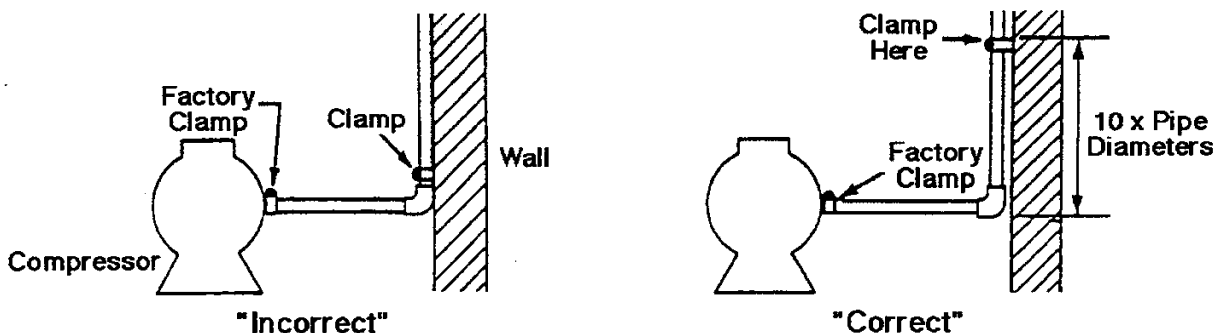

Suction Lines

NOTE: If the suction line must rise to a point higher than the suction connection on the evaporator, a suction line trap at the outlet of the evaporator must be provided.

Horizontal suction lines should slope away from the evaporator toward the compressor at the rate of 1/4 inch per 10 feet for good oil return. When multiple evaporators are connected in series using a common suction line, the branch suction lines must enter the top of the common suction line.

For dual or multiple evaporator systems, the branch lines to each evaporator should be sized for the evaporator capacity. The main common line should be sized for the total system capacity.

Suction lines that are outside of refrigerated space must be insulated. See **Leak Testing** section, item 2 on page 24 for more information.

Suction Line Risers

NOTE: To provide proper oil return, a suction trap must be provided at the base of all suction risers of four (4) feet or more.

Prefabricated wrought copper traps are available, or a trap can be made by using two street ells and one regular ell. The suction trap must be the same size as the suction line. For long vertical risers, additional traps may be necessary. Generally, one trap is recommended for each length of pipe (approximately 20 feet) to insure proper oil movement. See Figure 16 below for methods of constructing proper suction line P-traps.

Figure 16. Suction P-Traps.

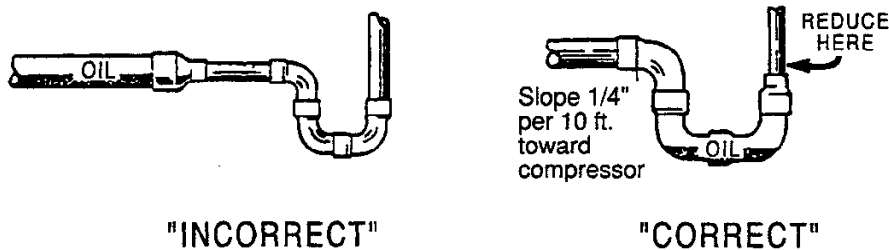
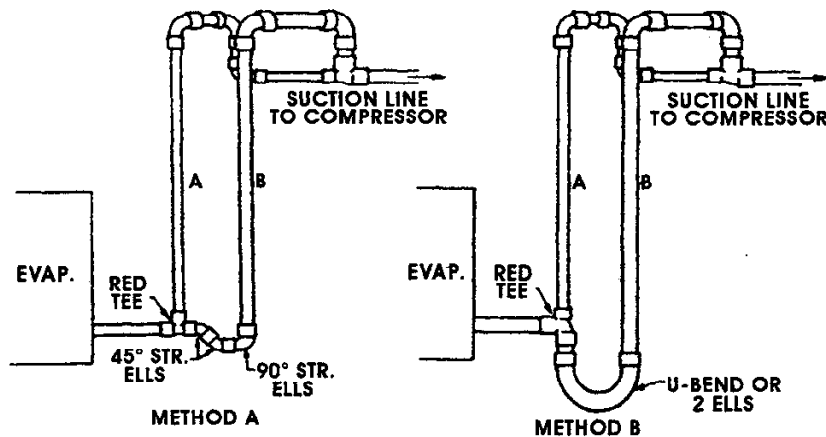

Figure 17. Double Suction Riser Construction



Liquid Lines

Liquid lines should be sized for a minimum pressure drop to prevent "flashing". Flashing in the liquid lines would create additional pressure drop and poor expansion valve operation. If a system requires long liquid lines from the receiver to the evaporator or if the liquid has to rise vertically upward any distance, the losses should be calculated to determine whether or not a heat exchanger is required. The use of a suction to liquid heat exchanger may be used to subcool the liquid to prevent flashing. This method of subcooling will normally provide no more than 20°F subcooling on high pressure

systems. The amount of subcooling will depend on the design and size of the heat exchanger and on the operating suction and discharge pressures. An additional benefit from the use of the suction to liquid type heat exchanger is that it can help raise the superheat in the suction line to prevent liquid return to the compressor via the suction line. Generally, heat exchangers are not recommended on R-22 low temperature systems. However, they have proved necessary on short, well insulated suction line runs to provide superheat at the compressor.

City / Tower Connections

In the refrigeration industry "City" and "Tower" are designations of temperature and flow conditions, not applications. The term "City" refers to operating conditions where incoming water is 75°F, and condensing temperature is 105°F. "Tower" refers to a higher temperature relationship which is normally 85°F, incoming water and 105°F condensing temperature.

Water circuits in some condenser models provide a center, or Tower, outlet connection to allow divided inlet water flow. This extra water port reduces water velocity, water pressure drop, and condenser wear in applications such as cooling towers where higher inlet temperatures and water flows occur.

Evacuation and Leak Detection

Due to the smaller molecule size of HFC's, they will tend to leak more readily than CFC. Consequently, it is of the utmost importance that proper system evacuation and leak detection procedures be employed.

Copeland recommends a minimum evacuation to 500 microns. In addition, a vacuum decay test is strongly recommended to assure there is not a large pressure differential between the system and vacuum pump. Good evacuation processes include frequent vacuum pump oil changes and large diameter, short hose connections to both high and low sides of the system preferably using bronze braided hose.

Leak detection can be carried out in the conventional manner. If HCFC or CFC tracer gas is used, care must be taken to completely remove all traces of the gas prior to introducing HFC's.

Electronic leak detectors are now available that will sense HFC's. This is considered preferable since it removes the possibility of chlorine remaining in the system after leak testing with HCFC's and/or CFC's. There is a view that even small quantities of chlorine may act as a catalyst encouraging copper plating and/or corrosion and should therefore be avoided.

Leak Testing

1. After all lines are connected, the entire system must be leak tested. The complete system should be pressurized to not more than 150 psig with refrigerant and dry nitrogen (or dry CO₂). The use of an electronic type leak detector is highly recommended because of its greater sensitivity to small leaks. As a further check it is recommended that this pressure be held for a minimum of 12 hours and then rechecked. For a satisfactory installation, the system must be leak tight.
2. After the final leak test, refrigerant lines exposed to high ambient conditions should be insulated to reduce heat pick-up and prevent the formation of flash gas in the liquid lines. Suction lines should be insulated with 3/4" wall Armstrong "Armaflex" or equal. Liquid lines should be insulated with 1/2 inch wall insulation or better. The insulation located in outdoor environments should be protected from UV exposure to prevent deterioration of insulating value.

Evacuation

CAUTION: Do not use the refrigeration compressor to evacuate the system. Do not start the compressor while it is in a vacuum.

A good, deep vacuum pump should be connected to both the low and high side evacuation valves with copper tube or high vacuum hoses (1/4" ID minimum). If the compressor has service valves, they should remain closed. A deep vacuum gauge capable of registering pressure in microns should be attached to the system for pressure readings.

A shut off valve between the gauge connection and vacuum pump should be provided to allow the system pressure to be checked after evacuation. Do not turn off vacuum pump when connected to an evacuated system before closing shut off valve.

Water Connections for City

For City water (open system) high pressure applications, the Tower connections is plugged.

Water Connections for Tower

For Tower usage and low pressure applications, both normal water connections will be used as inlets and the tower connection as an outlet.

Figure 18. Tower Connections

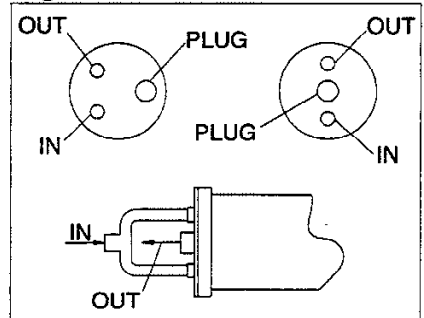

WARNING: HFC-134a has been shown to be combustible at pressure as low as 5.5 psig (at 350°F) when mixed with air at concentrations more than 60% air by volume. At lower temperature, higher pressures are required to support combustion. Therefore, air should never be mixed with HFC-134a for leak detection.

Within the last several years, manufacturers have developed fluorescent dye leak detection systems for use with refrigerants. These dyes mix with the lubricant and, when exposed to an ultraviolet light "fluoresce," indicates the location of leaks. Copeland has tested and approved the Rigid "System Safe" dye and found it to be compatible with the compressor materials in systems using mineral oil and HCFC-22. Testing has not been conducted by Copeland with HFC and POE; however, the suppliers of these dyes claim to have appropriate materials for the new refrigerants. If you intend on using this technique in a Copeland system, please consult Heatcraft Application Engineering for the status regarding approval of the dyes.

The vacuum pump should be operated until a pressure of 1,500 microns absolute pressure is reached — at which time the vacuum should be broken with the refrigerant to be used in the system through a drier until the system pressure rises above "0" psig.

NOTE: EPA regulations are constantly being updated to ensure your procedure follow correct regulations.

Repeat this operation a second time.

Open the compressor service valves and evacuate the entire system to 500 microns absolute pressure. Raise the pressure to 2 psig with the refrigerant and remove the vacuum pump.

Refrigerant Charging Instructions

1. Install a liquid line drier in the refrigerant supply line between the service gauge and the liquid service port of the receiver. This extra drier will insure that all refrigerant supplied to the system is clean and dry.
2. When initially charging a system that is in a vacuum, liquid refrigerant can be added directly into the receiver tank.
3. Check serial data tag attached to the unit for refrigerant capacity. System refrigerant capacity is 90% of receiver capacity. Do not add more refrigerant than the data tag indicates. Weigh the refrigerant drum before charging so an accurate record can be kept of the weight of refrigerant put in the system.
4. Start the system and finish charging until the sight glass indicates a full charge and the proper amount has been weighed in. If the refrigerant must be added to the system

through the suction side of the compressor, charge in vapor form only. Liquid charging must be done in the high side only or with liquid metering devices to protect the compressor.

Low Head Pressure Systems

If you are charging the system by using a clear sight glass as an indication of proper charge the following must be considered.

Check the condensing temperature. It must be above 105°F. If not, it will be necessary to reduce the amount of air going through the condenser from fans still running. Simply reduce the effective condenser face area to raise the discharge pressure above the equivalent 105°F condensing temperature and then proceed to charge to clear the sightglass. Adjust evaporator superheat at this time. Return to full condenser face area and allow the system to balance.

Field Wiring

WARNING: All wiring must be done in accordance with applicable codes and local ordinances.

The field wiring should enter the areas as provided on the unit. The wiring diagram for each unit is located on the inside of the electrical panel door. All field wiring should be done in a professional manner and in accordance with all governing codes. Before operating unit, double check all wiring connections, including the factory terminals. Factory connections can vibrate loose during shipment.

1. The nameplate on the unit is marked with the electrical characteristic for wiring the unit.
2. Consult the wiring diagram in the unit cooler and in the condensing unit for proper connections.

3. Wire type should be of copper conductor only and of the proper size to handle the connected load.
4. The unit must be grounded.
5. For multiple evaporator systems, the defrost termination controls should be wired in series. Follow the wiring diagrams for multiple evaporator systems carefully. This will assure complete defrost of all evaporators in the system.
6. If a remote defrost Timer is to be used, the Timer should be located outside the refrigerated space.
7. Air cooled condensers - due to multiple low amp motors, we recommend time delay fuse protection instead of circuit breakers.

Check-Out and Start-Up

After the installation has been completed, the following points should be covered before the system is placed in operation:

- (a) Check all electrical and refrigerant connections. Be sure they are all tight.
- (b) Observe compressor oil level before start-up. The oil level should be at or slightly above the 1/4 level of the sight glass. Refer to Table 16 on page 31 for proper compressor oil.
- (c) Remove upper mounting nuts on the compressor feet. Remove the shipping spacers. Install the neoprene washers onto the compressor feet. Replace the upper mounting nuts and washers, allowing 1/16" space between the mounting nut and the neoprene spacer.
- (d) Check high and low pressure controls, pressure regulating valves, oil pressure safety controls, and all other safety controls, and adjust if necessary.
- (e) Check the room thermostat for normal operation and adjust.
- (f) Wiring diagrams, instruction bulletins, etc. attached to the condensing units should be read and filed for future reference.
- (g) All fan motors on air cooled condensers, evaporators, etc. should be checked for proper rotation. Fan motor mounts should be carefully checked for tightness and proper alignment.
- (h) Electric and hot gas evaporator fan motors should be temporarily wired for continuous operation until the room temperature has stabilized.

- (i) Observe system pressures during charging and initial operation. Do not add oil while the system is short of refrigerant unless oil level is dangerously low.
- (j) Continue charging until system has sufficient refrigerant for proper operation. Do not overcharge. Remember that bubbles in a sight glass may be caused by a restriction as well as a shortage of refrigerant.
- (k) Do not leave unit unattended until the system has reached normal operating conditions and the oil charge has been properly adjusted to maintain the oil level at the center of the sight glass.

CAUTION: Extreme care must be taken in starting compressors for the first time after system charging. At this time all, of the oil and most of the refrigerant might be in the compressor, creating a condition which could cause compressor damage due to slugging. Activating the crankcase heater for 24 hours prior to start-up is recommended. If no crankcase heater is present, then directing a 500 watt heat lamp or other safe heat source on the lower shell of the compressor for approximately thirty minutes will be beneficial in eliminating this condition which might never reoccur.

WARNING: Scroll compressor is directional dependant. If noisy, change phase of input wiring.

Operational Check-Out

After the system has been charged and has operated for at least two hours at normal operating conditions without any indication of malfunction, it should be allowed to operate overnight on automatic controls. Then a thorough recheck of the entire system operation should be made as follows:

- (a) Check compressor discharge and suction pressures. If not within system design limits, determine why and take corrective action.
- (b) Check liquid line sight glass and expansion valve operation. If there are indications that more refrigerant is required, leak test all connections and system components and repair any leaks before adding refrigerant.
- (c) Observe oil level in compressor crankcase sight glass. Add oil as necessary to bring level to bottom 1/4 of the sight glass.
- (d) Thermostatic expansion valves must be checked for proper superheat settings. Feeler bulbs must be in positive contact with the suction line and should be insulated. Valves with high superheat causes low refrigeration capacity. Low superheat promotes liquid slugging and compressor bearing washout.
- (e) Using suitable instruments, carefully check line voltage and amperage at the compressor terminals.
- (f) The maximum approved settings for high pressure controls on Heatcraft air cooled condensing equipment is 400 psig. On air cooled systems, check as follows: Disconnect the fan motors or block the condenser inlet air. Watch high pressure gauge for cutout point. Recheck all safety and operating controls for proper operation and adjust if necessary.
- (g) Check defrost controls for initiation and termination settings, and length of defrost period. Set fail safe at length of defrost + 25%.
Example: 20 minute defrost + 5 minutes
= 25 minute fail safe
- (h) Check winter head pressure controls for pressure setting.
- (i) Check crankcase heater operation if used.
- (j) Install instruction card and control system diagram for use of building manager or owner.

System Balancing - Compressor Superheat

IMPORTANT: In order to obtain the maximum capacity from a system, and to ensure trouble-free operation, it is necessary to balance each and every system.

This is extremely important with any refrigeration system.

The critical value which must be checked is suction superheat.

Suction superheat should be checked **at the compressor** as follows:

1. Measure the suction pressure at the suction service valve of the compressor and determine the saturation temperature corresponding to this pressure from a "Temperature-Pressure" chart.
2. Measure the suction temperature of the suction line about one foot back from the compressor using an accurate thermometer.
3. Subtract the saturated temperature from the actual suction line temperature. The difference is superheat.

Phase Loss Monitor

The combination phase sequence and loss monitor relay protects the system against phase loss (single phasing), phase reversal (improper sequence) and low voltage (brownout). When phase sequence is correct and full line voltage is present on all three phases, the relay is energized as the red indicator light glows.

NOTE: If compressor fails to operate and the red indicator light on the phase monitor does not glow, then the supplied electrical current is not in phase with the monitor. This problem is easily corrected by the following steps:

Too low a suction superheat can result in liquid being returned to the compressor. This will cause dilution of the oil and eventual failure of the bearings and rings or in the extreme case, valve failure.

Too high a suction superheat will result in excessive discharge temperatures which cause a break down of the oil and results in piston ring wear, piston and cylinder wall damage.

It should also be remembered that the system capacity decreases as the suction superheat increases. For maximum system capacity, suction superheat should be kept as low as is practical. Copeland mandates a **minimum** superheat of 20°F **at the compressor**. *Heatcraft* recommends that the superheat **at the compressor** be between 30°F and 45°F.

If adjustments to the suction superheat need to be made, the expansion valve at the evaporator should be adjusted. See instructions on page 27.

1. Turn power off at disconnect switch.
2. Remove orange relay monitor from the socket.
3. Swap any two of the three power input wires (terminals 3, 4 and 5).
4. Replace orange relay monitor into the socket.
5. Turn power on. Red indicator light should glow and compressor should start.

Evaporator Superheat

Check Your Superheat. After the box temperature has reached or is close to reaching the desired temperature, the evaporator superheat should be checked and adjustments made if necessary. Generally, systems with a design TD of 10°F should have a superheat value of 6' to 10°F for maximum efficiency. For systems operating at higher TD's, the superheat can be adjusted to 12' to 15' °F as required.

NOTE: Minimum compressor suction superheat of 20°F may override these recommendations on some systems with short line runs.

To properly determine the superheat of the evaporator, the following procedure is the method Heatcraft recommends:

WARNING: If the condensing unit has no flooded condenser head pressure control, the condensing unit must have the discharge pressure above the equivalent 105°F condensing pressure. See refrigerant charging instructions on page 25.

1. Measure the temperature of the suction line at the point the bulb is clamped.
2. Obtain the suction pressure that exists in the suction line at the bulb location by either of the following methods:
 - a. A gauge in the external equalized line will indicate the pressure directly and accurately.

Defrost

Many types of control arrangements can be used. In some applications, it may not be necessary to have scheduled defrost periods. The normal "off cycle" of the compressor may be adequate to keep the evaporator coil clear of frost. In other applications, a defrost timer may be necessary to help assure a clear coil. In a medium temperature environment, "air defrost" is initiated by the timer, but the evaporator fans continue to operate to facilitate the melting of frost on the fin surface. Other types of defrost schemes

Defrost Thermostat

Adjustable (F25-209 Series)

The defrost duration is determined by the setting of the defrost termination thermostat. Initially, the thermostat should be set at mid-range. This will terminate the defrost at about a 60°F bulb temperature which will be satisfactory for most applications. A somewhat longer or shorter defrost can be obtained by adjusting the control clockwise for a shorter defrost and counterclockwise for a longer defrost. The fan delay temperature setting of the thermostat is factory set at 25°F. It can be adjusted upward by turning the adjusting screw next to the duration adjustment with a small screwdriver. Each complete clockwise rotation of this screw raises the setting approximately 3°F. This screw should not be adjusted more than four turns. Making this adjustment also raises the defrost termination temperature setting of the thermostat by a similar amount. For example, with the duration setting at mid-range, the termination temperature would be approximately 60°F. Turning the adjusting screw one turn would raise the fan delay temperature to about 28°F as well as changing the termination temperature from 60°F to 63°F. On medium temperature applications it may be necessary to raise the setting to assure that the thermostat will reset after a defrost.

Note: Defrost controls are positioned as determined by engineering test. Job conditions may require the sensing device to be relocated for optimal defrosting.

- b. A gauge directly in the suction line near the evaporator or directly in the suction header of the evaporator will yield the same reading as 2a above.
3. Convert the pressure obtained in 2a or 2b above to saturated evaporator temperature by using a temperature-pressure chart.
4. Subtract the saturated temperature from the actual suction line temperature. The difference is Superheat.

Alternative Superheat Method

The most accurate method of measuring superheat is found by following the previous procedure, Temperature/Pressure method. However, that method may not always be practical. An alternative method which will yield fairly accurate results is the temperature / temperature method:

1. Measure the temperature of the suction line at the point the bulb is clamped (outlet).
2. Measure the temperature of one of the distributor tubes close to the evaporator coil (inlet).
3. Subtract the inlet temperature from the outlet temperature. The difference is Superheat.

This method will yield fairly accurate results as long as the pressure drop through the evaporator coil is low.

require that the fans on the evaporator shut off during the defrost period.

For most applications, two to four defrost cycles per day should be adequate. The defrost requirements will vary on each installation so the defrost settings should be determined by observing the system operation.

Bimetal Disc

A bimetal disc type thermostat is wired to the control circuit to terminate the defrost cycle when the coil temperature reaches approximately 50°F. The bimetal disc thermostat provides a fan delay to allow moisture on the coil to freeze after defrost termination.

NOTE: On systems where the suction temperature is above approximately 25°F, the fans may not start for an extended period of time.

This can be corrected by jumping the fan switch contacts. This will allow the fans to start immediately after defrost termination. This will disable the fan delay.

If moisture blow-off is encountered without the fan delay, a higher temperature defrost thermostat can be ordered. This thermostat terminates defrost at 60°F and prevents the fans from running when the coil temperature is above 40°F. Refer to the replacement parts list for the correct number to order.

Sequence of Operation

Refrigeration Cycle

1. Power is supplied to the timer at terminals "1" and "N".
2. The fan delay and the defrost termination thermostat is closed in the fan delay position and open in the defrost termination position. The unit cooler fans run continuously.
3. The defrost heaters are off.
4. The room thermostat closes when the temperature rises above the desired setting.
5. The liquid line solenoid is energized and opens, which allows liquid refrigerant to flow through the unit cooler.
6. The low pressure control closes when the suction pressure rises above the cutin setting of the control.
7. On systems with oil pumps, the oil safety control is closed. If the net oil pressure is less than 9 PSIG for more than 120 seconds, the oil safety opens, thus breaking the circuit to the compressor contactor holding coil. The compressor will not operate. This control is reset manually and must be reset before the compressor can be restarted.
8. The compressor contactor closes. The compressor and condenser fan start simultaneously.
9. The room temperature gradually decreases to the desired temperature.
10. Once the desired temperature is reached, the thermostat opens and the liquid line solenoid closes, stopping refrigerant flow through the evaporator.
11. Suction pressure decreases and the compressor contactor opens when the pressure drops below the cutout setting on the low pressure control. The compressor and condenser fan stop running.
12. This cycle is repeated as many times as necessary to satisfy the room thermostat.

13. Frost starts to form on the evaporator coil and continues to form until the defrost cycle is initiated.

Defrost Cycle

1. The defrost cycle starts automatically by the timer at predetermined times. Typical settings are two to four defrost cycles per day for freezers. For heavier frost loads additional settings may be required.
2. Switch "2" to "4" opens in the time clock which breaks the circuit to the room thermostat, liquid line solenoid, and evaporator fan motors, allowing the compressor to pump down and shut off. Simultaneously switch "1" to "3" closes in the timer allowing current to flow to one side of the defrost heater contactor. When the compressor shuts off, an auxiliary contact will send power to the contactor holding coil; thus, energizing the defrost heaters.
3. The heaters raise the temperature of the coil to 32°F causing the frost to melt off the coil.
4. When the coil warms to 45°F to 55°F, the defrost termination thermostat closes, which allows current to the switching solenoid in the timer allowing the refrigeration cycle to begin again.
5. The evaporator heaters are off. If the termination thermostat fails to close, the fail-safe set on the timer will terminate defrost.
6. The low pressure control closes and the compressor will start.
7. When the coil temperature reaches 23°F to 30°F, the fan delay closes. This allows the current to flow to the fan motors. The fan motors start running.
8. The system will now operate in the refrigeration cycle until another defrost period is initiated by the timer.

NOTES:

1. Lockout relays or normally closed switch of auxiliary contact on the compressor contactor may be wired to defrost contactor. Its purpose is to prevent energizing of the defrost heaters until the compressor has pumped down and stopped, thus keeping power demand to a minimum.
2. If the control voltage is to remain energized for any period of time with the compressor disabled, remove the defrost clock pins to prevent the defrost heaters from energizing.
3. A Preventative Maintenance schedule should be set up as soon as possible after start-up to maintain equipment integrity.

Head Pressure Control*

Several types of head pressure control systems are available on condensing units:

- A. Dual Valve System. (See section on operation and adjustment.)
- B. Single Valve system. No adjustments are necessary. (See section on operation.)
- C. Ambient Fan Cycle Control. (See section on operation and adjustment.)
- D. No Control.

* If applicable, refer to supplemental installation manual

A. Dual Valve System

This is an energy efficient low ambient control. The system employs an ORI (open on rise of inlet pressure) valve and an ORD (open on rise of differential pressure) valve. The high pressure discharge gas is introduced above the liquid in the receiver tank. The receiver discharge is regulated by the ORI valve.

The discharge pressure of the ORI valve must be adjusted to regulate the unit for proper operating conditions. Adjust the ORI valve shown on the following diagram to maintain a discharge pressure of 160 to 180 PSIG.

Figure 19. Dual Valve Piping Arrangement

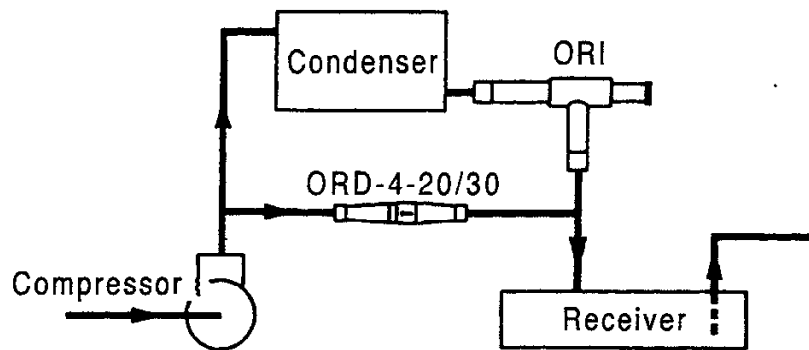

Operation and Adjustment

Condensing units with dual valves require sufficient charge to partially flood the condenser during low ambient conditions.

Valve adjustment should be made with gauges connected to the discharge port of the compressor. Adjustments should be made during mild or low ambient conditions. Turning the valve stem "clockwise" on the ORI valve will increase the discharge pressure, while turning the valve stem "counterclockwise" will decrease the discharge pressure.

If adjustments are made during warm ambient conditions, it may not be possible to adjust the regulator valve as low as desired. Readjustment may be necessary once cooler conditions prevail.

B. Single Valve System

The standard valve used on high pressure refrigerant systems controls the discharge pressure at approximately 180 PSIG.

There is no adjustment for this valve. On low pressure refrigerant systems the valve controls pressure at approximately 100 PSIG. For energy efficiency, the 100 PSIG valve is sometimes used on high pressure refrigerant systems. When this is done, refer to Table 1 on page 4 for expansion valve selections.

At condensing pressures above the valve setting, flow enters Port C and leaves Port R. When the condensing pressure falls below the valve setting, the valve modulates to permit discharge gas to enter Port D. Metering discharge gas into the refrigerant flow leaving the condenser produces a higher pressure at the condenser outlet, reduces the flow, and causes the level of liquid refrigerant to rise in the condenser. This "flooding" of the condenser with liquid refrigerant reduces the available condensing surface, holding the condensing pressure at the valve setting.

Figure 20. Single Valve Flooding Valve Piping Arrangement

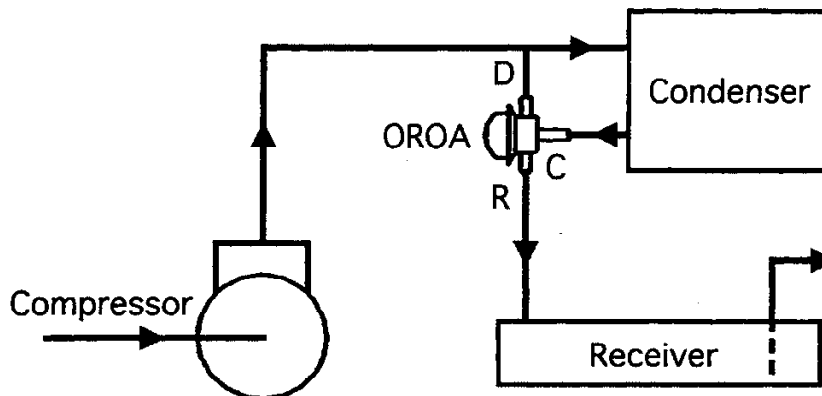

C. Ambient Fan Cycle Control

This is an automatic winter control method which will maintain a condensing pressure within reasonable limits by cycling fan motors in response to outside air temperature. The thermostat(s) should be field adjusted to shut off the fan when the condensing temperature is reduced to approximately 90°F. Table 15 on page 30 lists approximate settings for several system T.D.'s. These settings are approximate as they do not take into account variations in load.

CAUTION: Under no circumstance should all condenser motors be allowed to cycle off on one control. At least one motor shall be wired to operate at all times. Under most circumstances, the condenser motor nearest the inlet header should remain on whenever the compressor is operating.

Suction Filters, Driers, Sight Glasses

There are two types of suction and liquid filter/driers used on **Heatcraft** units. Replaceable core and/or sealed units are used, dependent upon the option package ordered.

Suction filters, regardless of type, are always installed upstream of the compressor suction service valve, and any accumulators or other options that may be installed. Suction filters are equipped with "Schrader" type access valves to allow field measurement of pressure drop across the device. This allows plugged filters and elements to be identified very quickly and easily so they can be replaced when the pressure drop is excessive. Refer to the specific manufacturers' recommendation on servicing these units by make and model.

Liquid filter/driers, regardless of type, are always installed downstream of the receiver outlet service valve, and upstream of the liquid line solenoid valve (if supplied). Liquid line driers

may or may not have an access valve, dependent on the size and application. The basic servicing of these units is similar to suction filters. Liquid line driers should be replaced whenever there is evidence of excessive pressure drop across the filter, or the system becomes contaminated due to system leaks, compressor burnouts, acid formation, or moisture accumulation as indicated by the liquid line sight glass.

The sight glass is installed in the main liquid line assembly, downstream from the receiver outlet service valve, and immediately after the liquid line drier. The sight glass is designed to give a visual indication of moisture content in the system. Generally, it requires no field service. However, in cases of extreme acid formation in a system after a compressor burnout, the acid may damage the sensing element or etch the glass. This would require that the sight glass be replaced, along with the liquid line drier after any compressor motor burnout.

Table 14. Recommended Low Pressure Control Settings for Outdoor Air Cooled Condensing Units

*Minimum Temp. °F	R-22		R-502		R-404A/R-507		R-134a/R-12	
	Cut-In PSI	Cut-Out PSI	Cut-In PSI	Cut-Out PSI	Cut-In PSI	Cut-Out PSI	Cut-In PSI	Cut-Out PSI
50	70	20	80	30	90	35	45	15
40	55	20	65	30	70	35	35	10
30	40	20	50	30	55	35	25	10
10	30	10	40	20	45	25	13	0
0	15	0	20	5	25	7	8	0
-10	15	0	15	0	20	1	---	---
-20	10	0	10	0	12	1	---	---
-30	6	0	6	3" Hg.	8	1"Hg.	---	---

* Minimum ambient or box temperature anticipated, Hi pressure control setting: R-22 & R-502, 360 PSI; R-404A, R-507, 400 PSI; R-134, R-12, 225 PSI.

Table 15. Thermostat Settings

Models	Design T.D.	Thermostat Settings		
		T1	T2	T3
2-fan units:	30	60		
	25	65		
	20	70		
4-fan units:	15	75		
	30	60	40	
3-fan units:	25	65	55	
	20	70	60	
	15	75	65	
6-fan units:	30	60	50	30
	25	65	55	40
	20	70	65	50
	15	75	70	60

NOTE: Cycle pairs of fans on double wide units.

CAUTION: Fans closest to the headers should not be cycled on standard temperature or pressure controls. Dramatic temperature and pressure changes at the headers as a result of fan action can result in possible tube failure. Fan motors are designed for continuous duty operation.

Fan cycling controls should be adjusted to

maintain a minimum of (5) minutes on and (5) minutes off. Short cycling of fans may result in a premature failure of motor and/or fan blade.

Compressors operating below +18°F SST must have air flowing over the compressor at all times when the compressor is running.

Refrigeration Oils*

With the changes that have taken place in our industry due to the CFC issue, we have reevaluated our lubricants to ensure compatibility with the new HFC refrigerants and HCFC interim blends offered by several chemical producers. As a secondary criteria, it is also desirable that any new lubricant be compatible with the traditional refrigerants such as CFC-12, HCFC-22 or R502. This "backward compatibility" has been achieved with the introduction of the Polyol ester lubricants.

Table 16 below summarizes which oils/lubricants are approved for use in Copeland compressors:

Polyol Ester Lubricants

Hygroscopicity

Ester lubricants (POE) have the characteristic of quickly absorbing moisture from the ambient surroundings. This is shown graphically in Figure 21 where it can be seen that such lubricants absorb moisture faster and in greater quantity than conventional mineral oils. Since moisture levels greater than 100 ppm will result in system corrosion and ultimate failure, it is imperative that compressors, components, containers and the entire system be kept sealed as much as possible. Lubricants will be packaged in specially designed, sealed containers. After opening, all the lubricant in a container should be used at once since it will readily absorb moisture if left exposed to the ambient. Any unused lubricant should be properly disposed of. Similarly, work on systems and compressors must be carried out with the open time as short as possible. Leaving the system or compressor open during breaks or overnight **MUST BE AVOIDED!**

Color

As received, the POE lubricant will be clear or straw colored. After use, it may acquire a darker color. This does not indicate a problem as the darker color merely reflects the activity of the lubricant's protective additive.

Oil Level

During Copeland's testing of Polyol ester oil, it was found that this lubricant exhibits a greater tendency to introduce oil into the cylinder during flooded start conditions. If allowed to continue, this condition will cause mechanical failure of the compressor.

A crankcase heater is required with condensing units and it must be turned on several hours before start-up.

Oil level must not exceed 1/4 sight glass.

Figure 21. Hygroscopicity

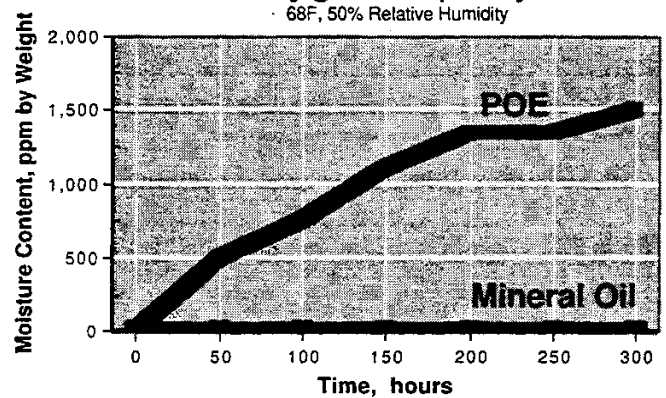

Table 16. Refrigeration Oils

Refrigeration Oils		Traditional Refrigerants CFC-12, HCFC-22, R502	Interims R401A, R401B, R402A (MP-39, MP-66, HP-80)	HFC's HFC-134a, R404A
POE's	Mobil EAL ARCTIC 22 CC	A	A	P
	ICI (Virginia KMP) EMKARATE RL 32CF	A	A	P
Mineral Oils	Suniso 3GS	P	PM	NOT ACCEPTABLE
	Texaco WF32	P	PM	
	Calumet R015 (Witco)	P	PM	
	Sontex 200-LT (White Oil)	(BR & Scroll Only)		
	Witco LP-200	P		
A/B	Zerol 200TD	AM	PM	NOT ACCEPTABLE
	Soltex Type AB-200		PM	

P = Preferred Lubricant Choice

A = Acceptable Alternative

M = Mixture of Mineral Oil and Alkyl Benzene (AB) with minimum 50% AB.

* (Reprinted from Copeland)

Mineral Oils

The BR and Scroll compressors use Sontex 200, a "white oil". This oil is not suitable for low temperature applications nor is it available through the normal refrigeration wholesalers. For field "top-off" the use of 3GS or equivalent, or Zerol 200TD is permissible, as long as at least 50% of the total oil charge remains Sontex 200.

Suniso 3GS, Texaco WF32 and Calumet R015 (yellow oils) are available through normal refrigeration wholesalers. These oils are compatible if mixed and can be used on both high and low temperature systems.

Polyol Ester Lubricants

The Mobil EAL ARCTIC 22 CC is the preferred Polyol ester due to unique additives included in this lubricant. ICI Emkarate RL 32S is an acceptable Polyol ester lubricant approved for use when Mobil is not available. These POE's **must** be used if HFC refrigerants are used in the system. They are also acceptable for use with any

of the traditional refrigerants or interim blends and are compatible with mineral oils. They can therefore be mixed with mineral oils when used in systems with CFC or HCFC refrigerants. These lubricants are compatible with one another and can be mixed.

Alkyl Benzenes

Zerol 200TD is an alkyl benzene (AB) lubricant. Copeland recommends this lubricant for use as a mixture with mineral oil (MO) when using the interim blends such as R-401A, R-401B and R-402A (MP39, MP66 and HP80). A minimum of 50% AB is required in these mixtures to assure proper oil return.

Shell MS 2212 is a 70/30 mixture of AB/MO. If this lubricant is used in a retrofit situation virtually all of the existing MO must be drained prior to refilling with the MS 2212 to assure a minimum 50% AB content.

Table 17. System Troubleshooting Chart

PROBLEM	POSSIBLE CAUSES	POSSIBLE CORRECTIVE STEPS
Compressor will not run	<ol style="list-style-type: none"> 1. Main switch open. 2. Fuse blown. 3. Thermal overloads tripped. 4. Defective contactor or coil. 5. System shut down by safety devices. 6. No cooling required. 7. Liquid line solenoid will not open. 8. Motor electrical trouble. 9. Loose wiring. 10. Phase loss monitor inoperative. 	<ol style="list-style-type: none"> 1. Close switch. 2. Check electrical circuits and motor winding for shorts or grounds. Investigate for possible overloading. Replace fuse after fault is corrected. 3. Overloads are automatically reset. Check unit closely when unit comes back on line. 4. Repair or replace. 5. Determine type and cause of shutdown and correct it before resetting safety switch. 6. None. Wait until calls for cooling. 7. Repair or replace coil. 8. Check motor for open windings, short circuit or burn out. 9. Check all wire junctions. Tighten all terminal screws. 10. Refer to page 26.
Compressor noisy or vibrating	<ol style="list-style-type: none"> 1. Flooding of refrigerant into crankcase. 2. Improper piping support on suction or liquid line. 3. Worn compressor. 4. Scroll compressor rotation reversed. 	<ol style="list-style-type: none"> 1. Check setting of expansion valves. 2. Relocate, add or remove hangers. 3. Replace. 4. Rewire for phase change.
High discharge pressure	<ol style="list-style-type: none"> 1. Non-condensables in system. 2. System overcharges with refrigerant. 3. Discharge shutoff valve partially closed. 4. Fan not running. 5. Head pressure control setting. 6. Dirty condenser coil. 	<ol style="list-style-type: none"> 1. Remove the non-condensables. 2. Remove excess. 3. Open valve. 4. Check electrical circuit. 5. Adjust. 6. Clean.
Low discharge pressure	<ol style="list-style-type: none"> 1. Faulty condenser temperature regulation. 2. Suction shutoff valve partially closed. 3. Insufficient refrigerant in system. 4. Low suction pressure. 5. Variable head pressure valve. 	<ol style="list-style-type: none"> 1. Check condenser control operation. 2. Open valve. 3. Check for leaks. Repair and add charge. 4. See corrective steps for low suction pressure. 5. Check valve setting.
High suction pressure	<ol style="list-style-type: none"> 1. Excessive load. 2. Expansion valve overfeeding. 	<ol style="list-style-type: none"> 1. Reduce load or add additional equipment. 2. Check remote bulb. Regulate superheat.
Low suction pressure	<ol style="list-style-type: none"> 1. Lack of refrigerant. 2. Evaporator dirty or iced. 3. Clogged liquid line filter drier. 4. Clogged suction line or compressor suction gas strainers. 5. Expansion valve malfunctioning. 6. Condensing temperature too low. 7. Improper TXV. 	<ol style="list-style-type: none"> 1. Check for leaks. Repair and add charge. 2. Clean. 3. Replace cartridge(s). 4. Clean strainers. 5. Check and reset for proper superheat. 6. Check means for regulating condensing temperature. 7. Check for proper sizing.
Little or no oil pressure	<ol style="list-style-type: none"> 1. Clogged suction oil strainer. 2. Excessive liquid in crankcase. 3. Low oil pressure safety switch defective. 4. Worn oil pump. 5. Oil pump reversing gear stuck in wrong position. 6. Worn bearings. 7. Low oil level. 8. Loose fitting on oil lines. 9. Pump housing gasket leaks. 	<ol style="list-style-type: none"> 1. Clean. 2. Check crankcase heater. Reset expansion valve for higher superheat. Check liquid line solenoid valve operation. 3. Replace. 4. Replace. 5. Reverse direction of compressor rotation. 6. Replace compressor. 7. Add oil and/or through defrost. 8. Check and tighten system. 9. Replace gasket.
Compressor loses oil	<ol style="list-style-type: none"> 1. Lack of refrigerant. 2. Excessive compression ring blowby. 3. Refrigerant flood back. 4. Improper piping or traps. 	<ol style="list-style-type: none"> 1. Check for leaks and repair. Add refrigerant. 2. Replace compressor. 3. Maintain proper superheat at compressor. 4. Correct piping.
Compressor thermal protector switch open.	<ol style="list-style-type: none"> 1. Operating beyond design conditions. 2. Discharge valve partially shut. 3. Blown valve plate gasket. 4. Dirty condenser coil. 5. Overcharged system. 	<ol style="list-style-type: none"> 1. Add facilities so that conditions are within allowable limits. 2. Open valve. 3. Replace gasket. 4. Clean coil. 5. Reduce charge.

Maintenance

Evaporators

All evaporator units should be checked once a month or more often for proper defrosting because the amount and pattern of frosting can vary greatly. It is dependent on the temperature of the room, the type of product being stored, how often new product is brought into the room and percentage of time the door to the room is open. It may be necessary to periodically change the number of defrost cycles or adjust the duration of defrost.

Condensing Units / Evaporators

Under normal usage conditions, maintenance should cover the following items at least once every six months.

1. Check and Tighten **ALL** electrical connections.
2. Check all wiring and insulators.

3. Check contactors for proper operation and for worn contact points.
4. Check all fan motors. Tighten motor mount bolts/nuts and tighten fan set screws.
5. Clean the condenser coil surface.
6. Check the refrigerant and oil level in the system.
7. Check the operation of the control system. Make certain all safety controls are operating properly.
8. Check that all defrost controls are functioning properly.
9. Clean the evaporator coil surface.
10. Clean the drain pan and check the drain pan and drain line for proper drainage.
11. Check the drain line heater for proper operation, cuts and abrasions.
12. Check and tighten all flare connections.

Table 18. Evaporator Troubleshooting Chart

SYMPTOMS	POSSIBLE CAUSES	POSSIBLE CORRECTIVE STEPS
Fan(s) will not operate.	<ol style="list-style-type: none"> 1. Main switch open. 2. Blown fuses. 3. Defective motor. 4. Defective Timer or defrost thermostat. 5. Unit in defrost cycle. 6. Coil does not get cold enough to reset thermostat. 	<ol style="list-style-type: none"> 1. Close switch. 2. Replace fuses. Check for short circuits or overload conditions. 3. Replace motor. 4. Replace defective component. 5. Wait for completion of cycle. 6. Adjust fan delay setting of thermostat. See Defrost Thermostat Section of this bulletin.
Room temperature too high.	<ol style="list-style-type: none"> 1. Room thermostat set too high. 2. Superheat too high. 3. System low on refrigerant. 4. Coil iced-up. 	<ol style="list-style-type: none"> 1. Adjust thermostat. 2. Adjust thermal expansion valve. 3. Add refrigerant. 4. Manually defrost coil. Check defrost controls for malfunction.
Ice accumulating on ceiling around evaporator and/or on fan guards venturi or blades.	<ol style="list-style-type: none"> 1. Defrost duration is too long. 2. Fan delay not delaying fans after defrost period. 3. Defective defrost thermostat or Timer. 4. Too many defrosts. 	<ol style="list-style-type: none"> 1. Adjust defrost termination thermostat. 2. Defective defrost thermostat or not adjusted properly. 3. Replace defective component. 4. Reduce number of defrosts.
Coil not clearing of frost during defrost cycle.	<ol style="list-style-type: none"> 1. Coil temperature not getting above freezing point during defrost. 2. Not enough defrost cycles per day. 3. Defrost cycle too short. 4. Defective Timer or defrost thermostat. 	<ol style="list-style-type: none"> 1. Check heater operation. 2. Adjust Timer for more defrost cycles. 3. Adjust defrost thermostat or Timer for longer cycle. 4. Replace defective component.
Ice accumulating in drain pan	<ol style="list-style-type: none"> 1. Defective heater. 2. Unit not pitched properly. 3. Drain line plugged. 4. Defective drain line heater. 5. Defective Timer or thermostat. 	<ol style="list-style-type: none"> 1. Replace heater. 2. Check and adjust if necessary. 3. Clean drain line. 4. Replace heater. 5. Replace defective component.

Diagram 1. Typical Wiring Diagram for Multiple Evaporators with Heater Limit Defrost and Evaporator Fan Contactors.

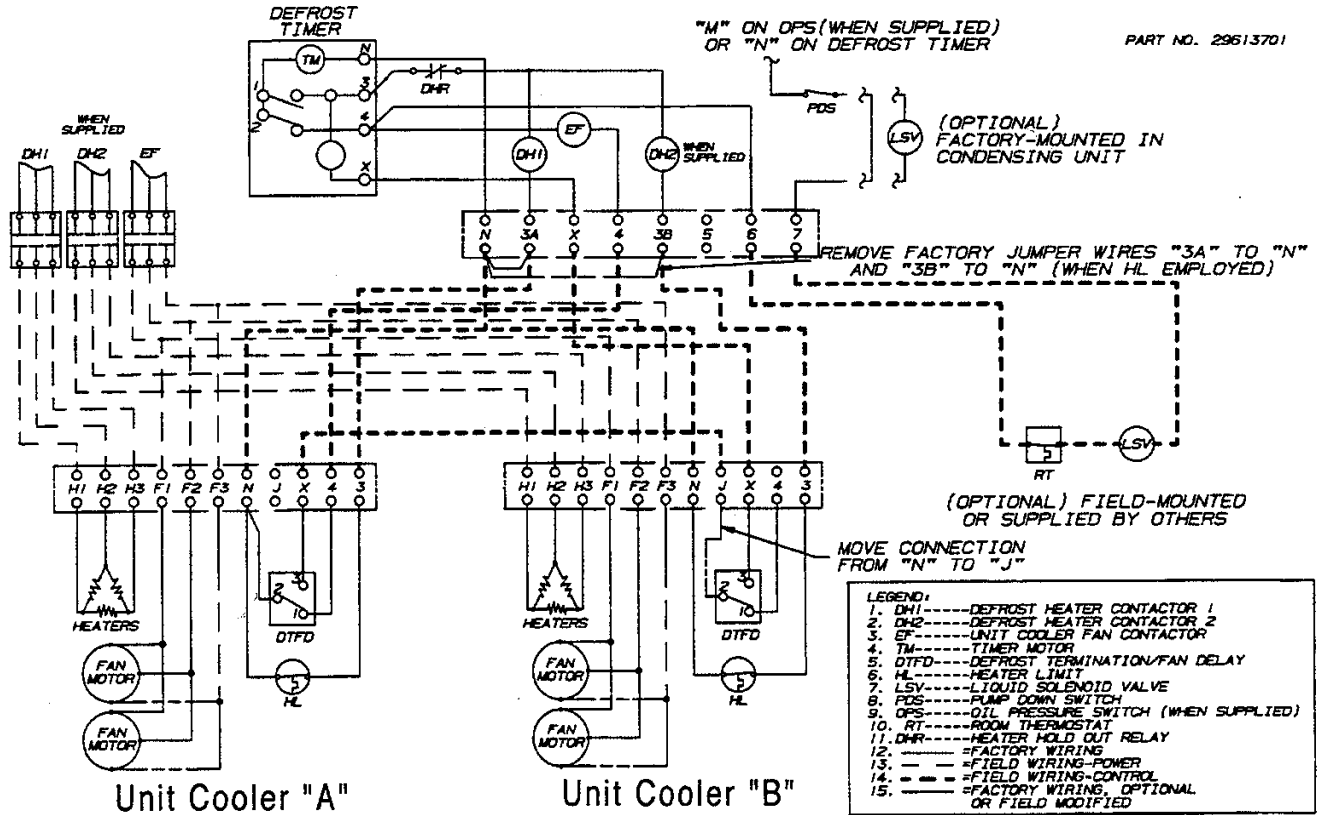

Diagram 2. Typical Wiring Diagram for Multiple Evaporators without Heater Limit Defrost and Evaporator Fan Contactors.

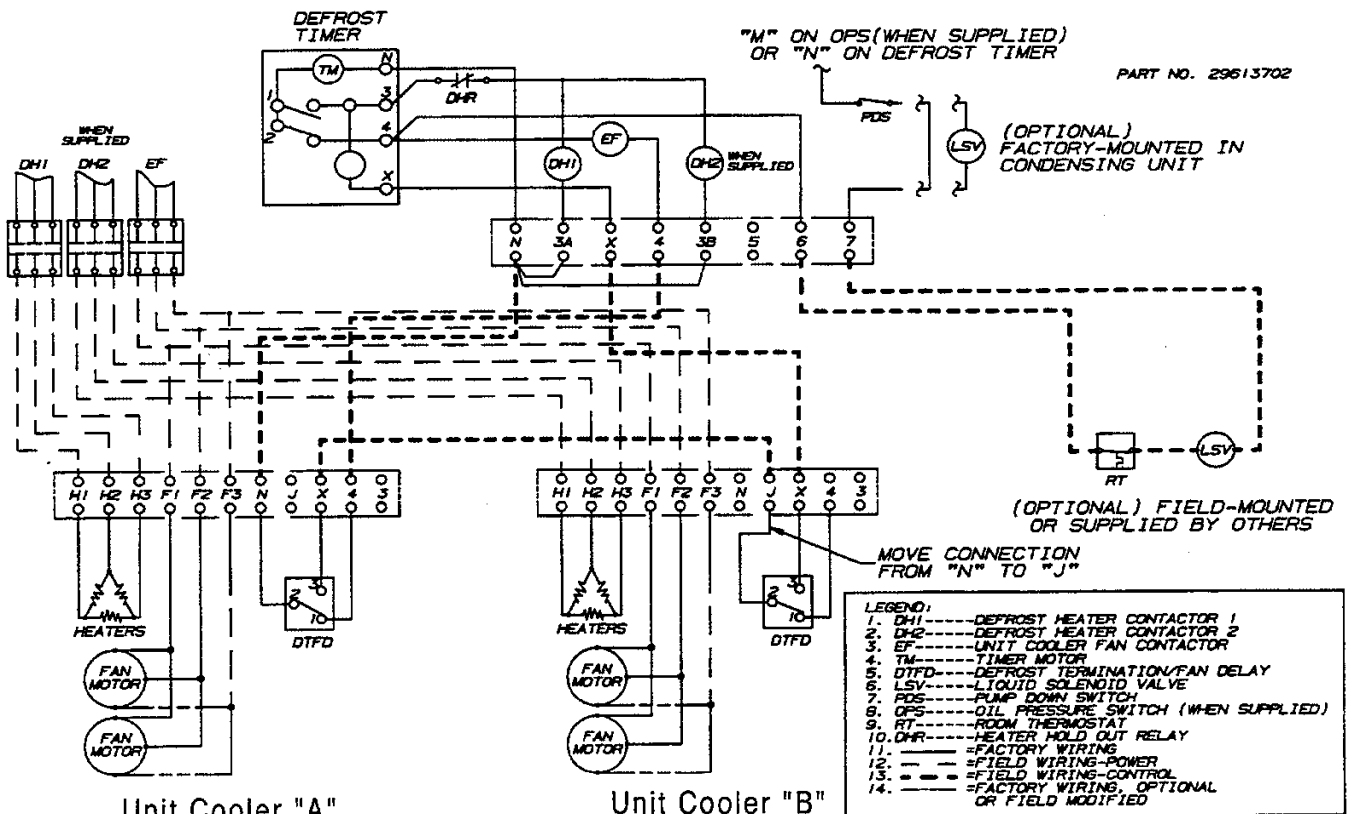

Diagram 3. Typical Wiring Diagram for Single Evaporator / Single Phase Voltage Defrost and Evaporator Fan Contactors.

PART NO. 29613715

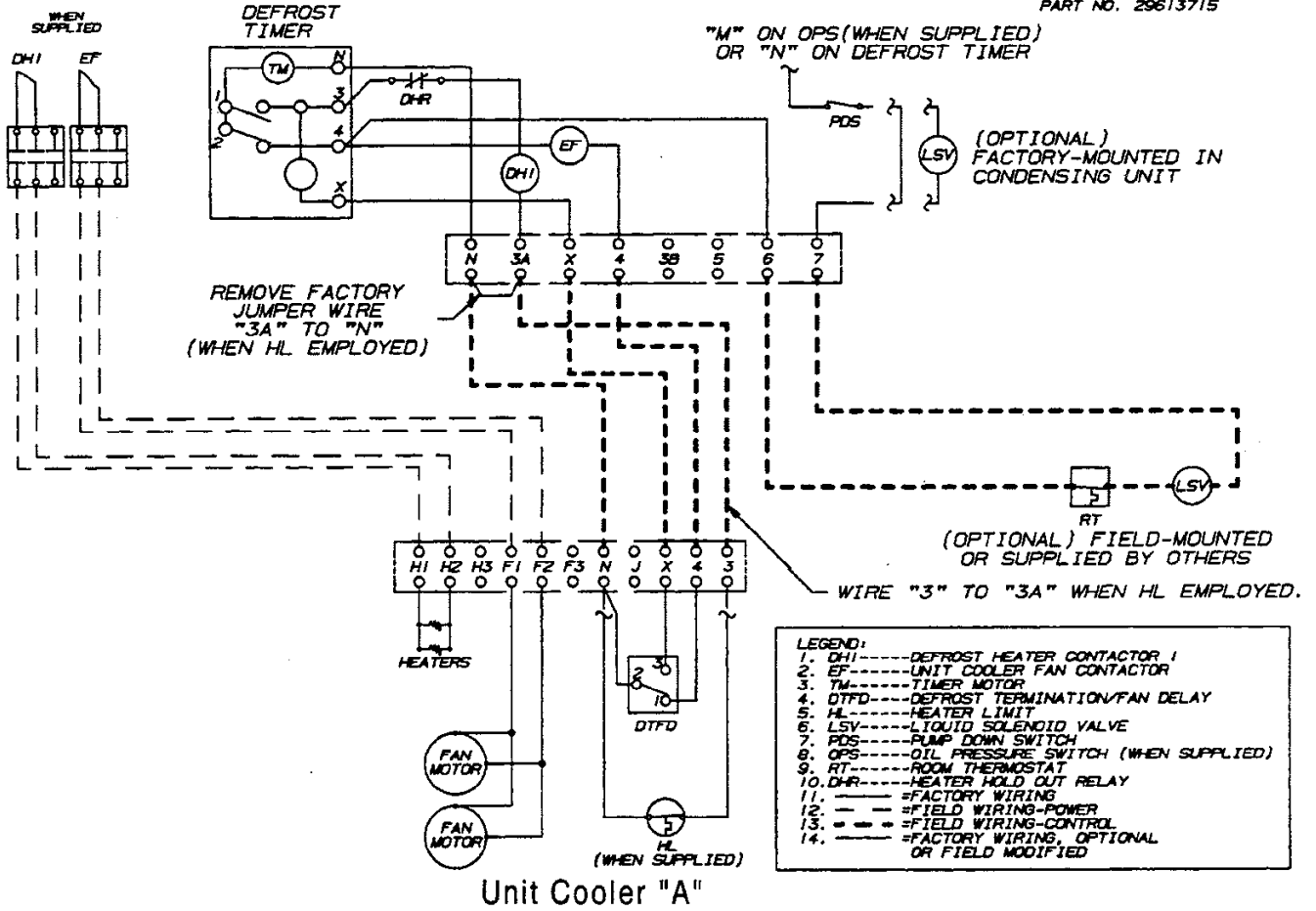

Diagram 4. Typical Wiring Diagram for Single Evaporator Defrost and Evaporator Fan Contactors.

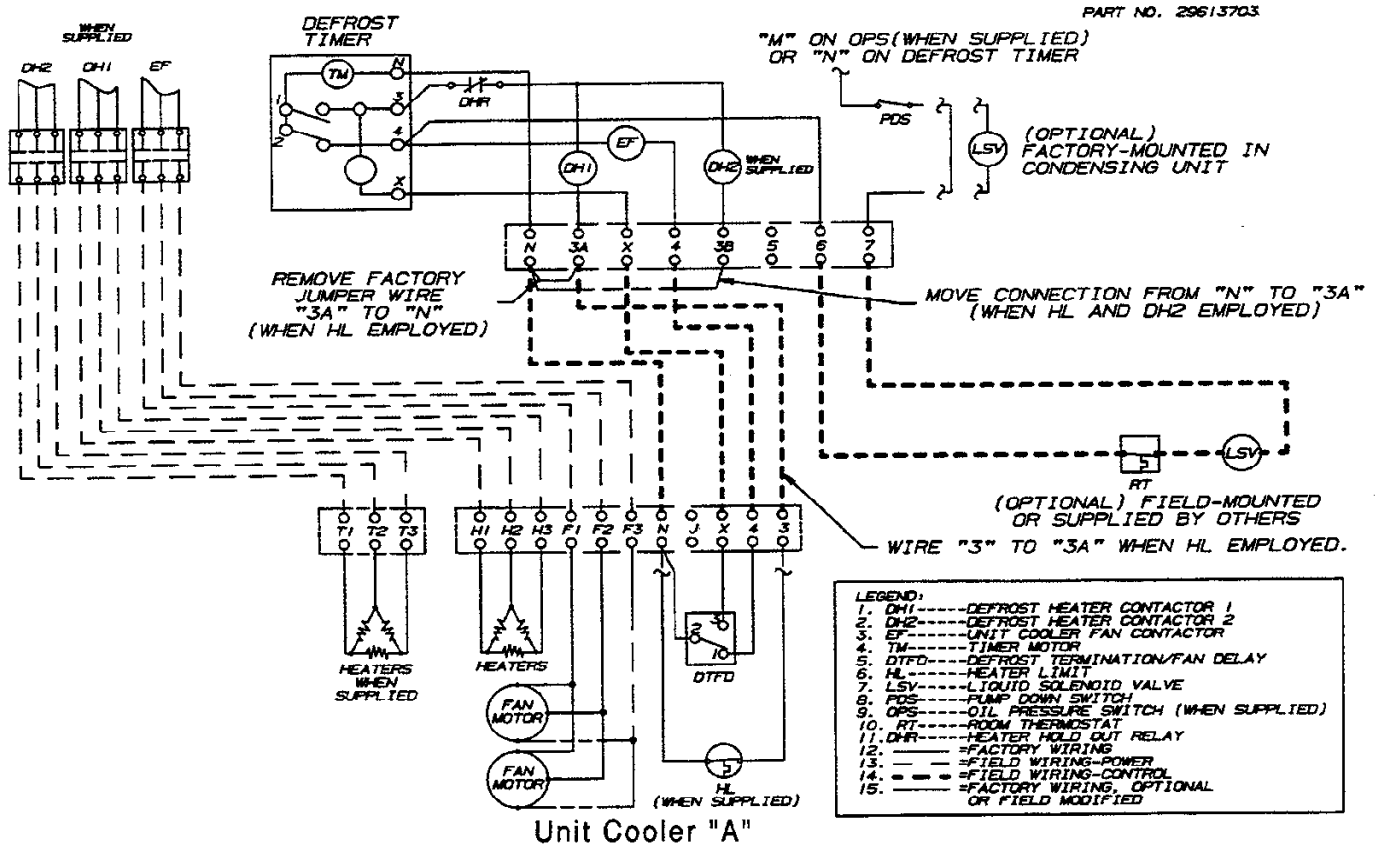

Diagram 5. Typical Wiring Diagram for Multiple Evaporators with Defrost Timer Only.

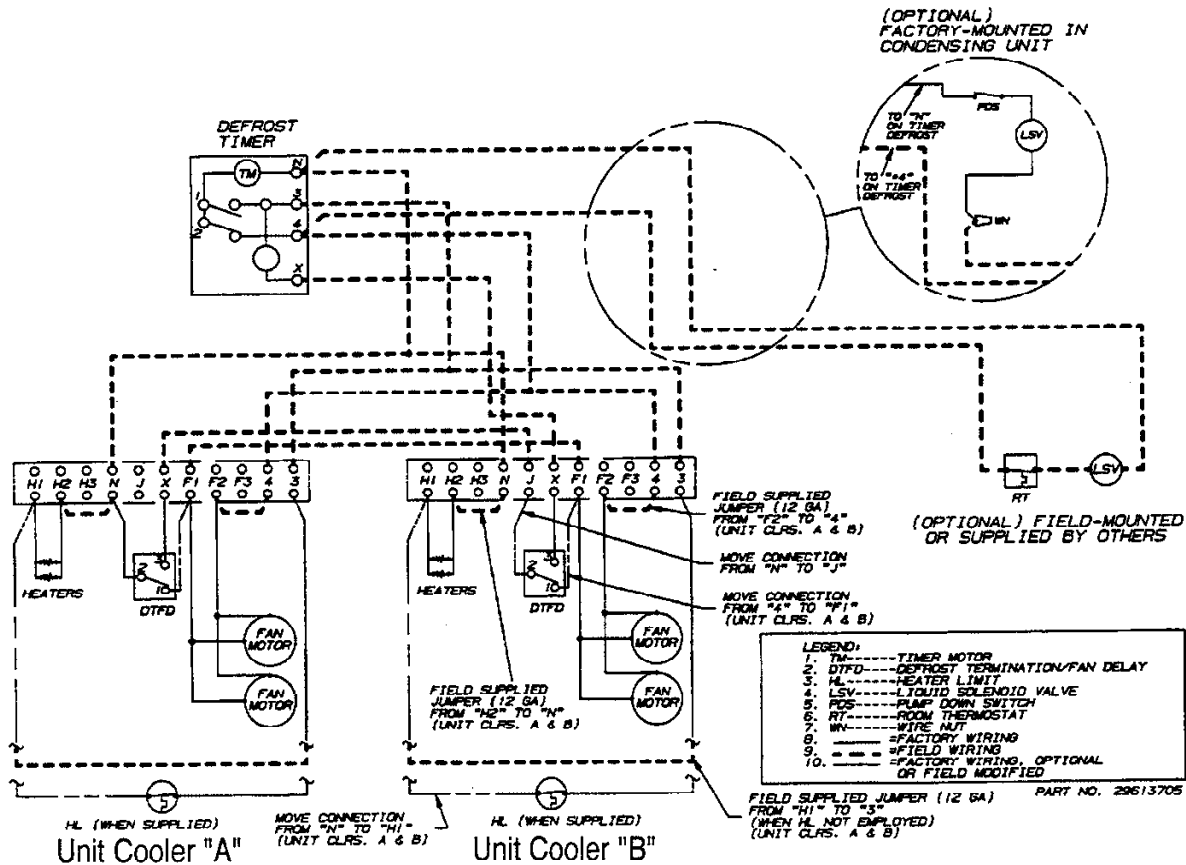

Diagram 6. Typical Wiring Diagram for Single Evaporator with Defrost Timer Only.

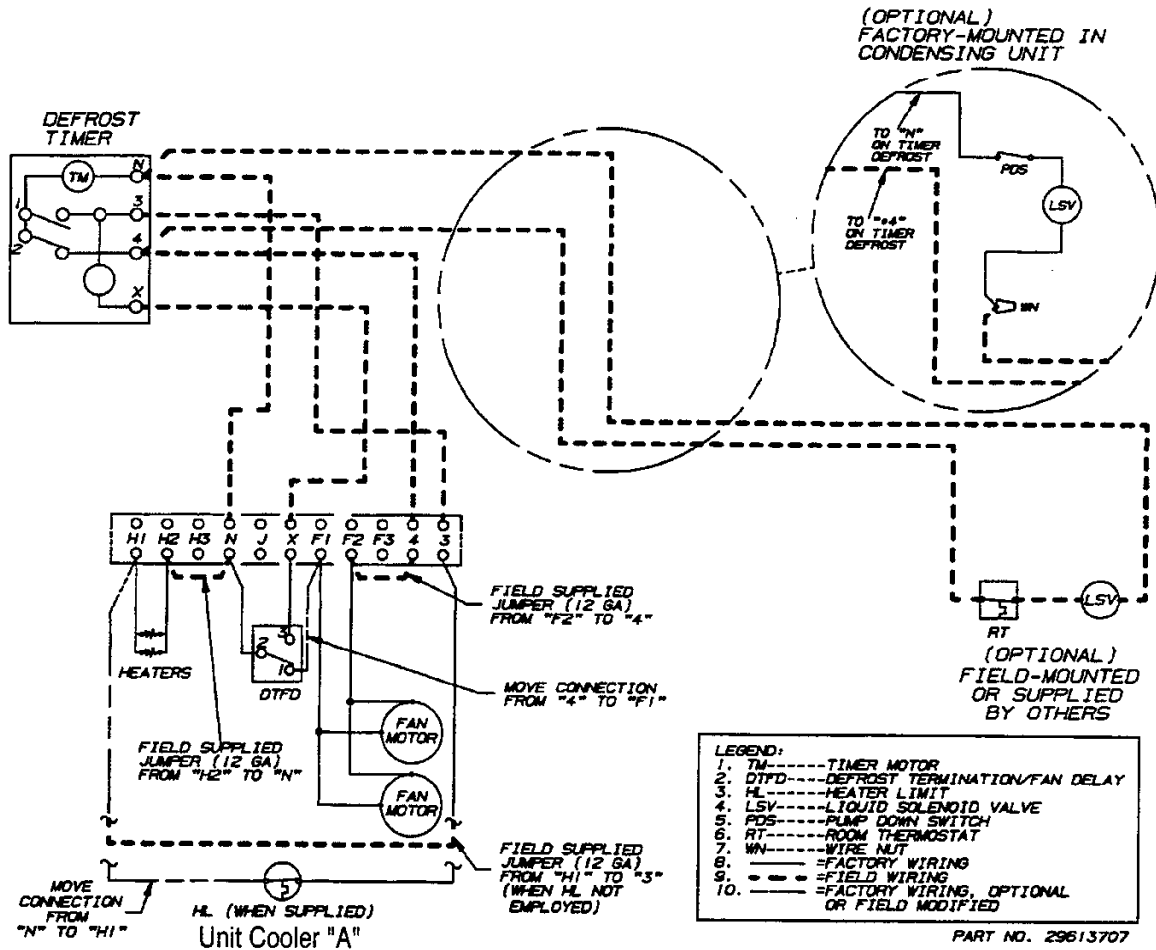

Diagram 7. Typical Wiring Diagram for Multiple Evaporators Defrost and Evaporator Fan Contactors with Unit Cooler Holdout Relay.

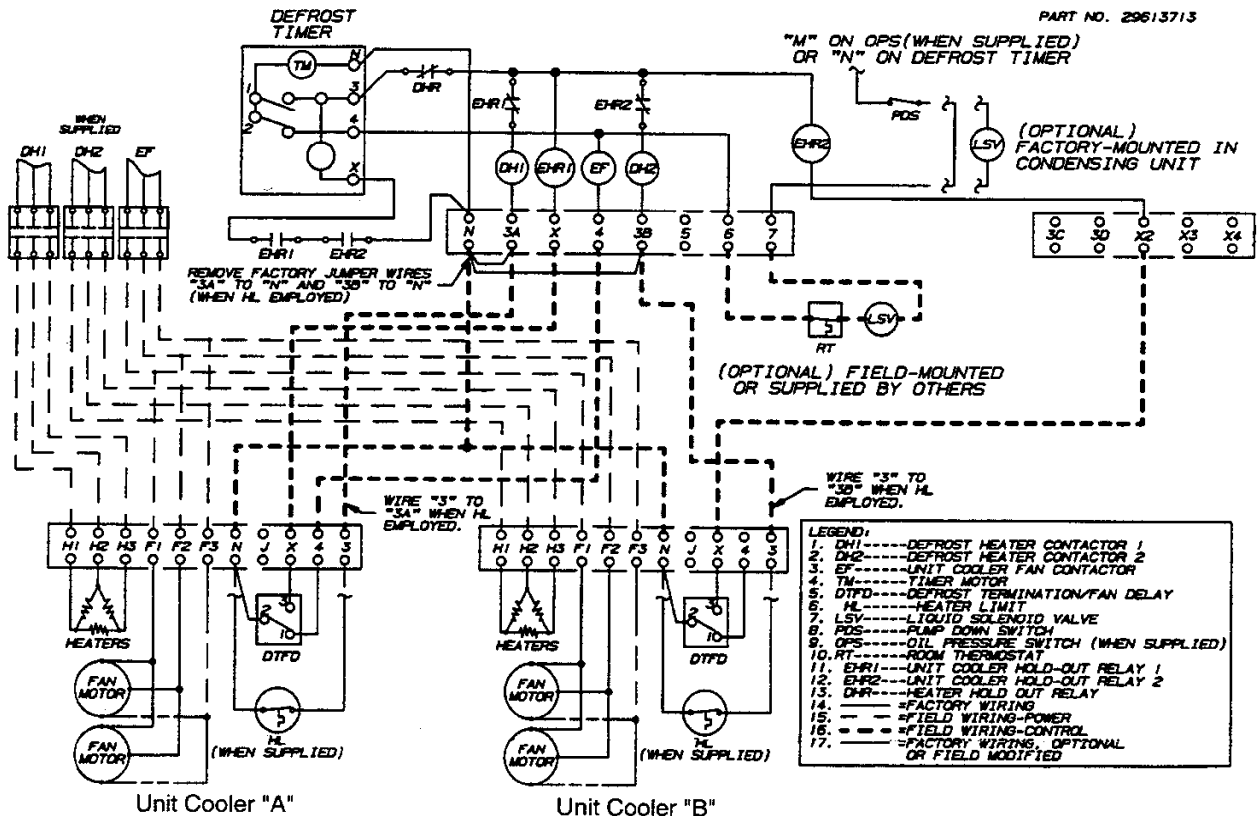
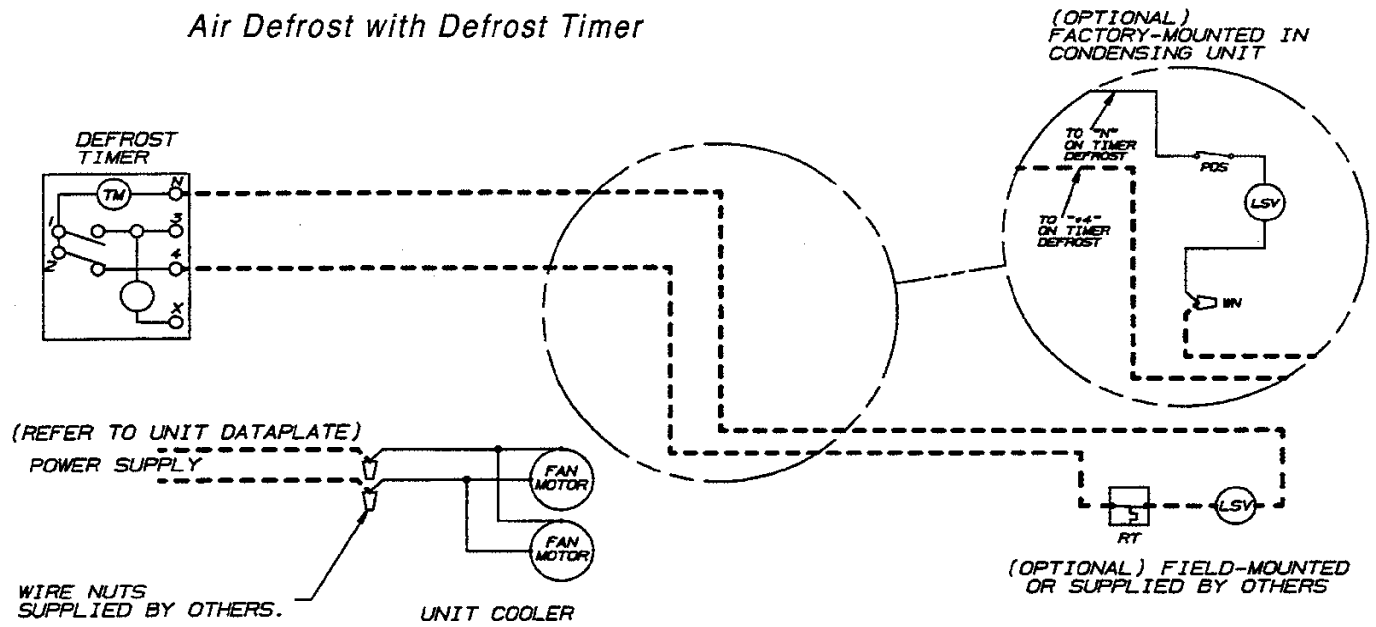
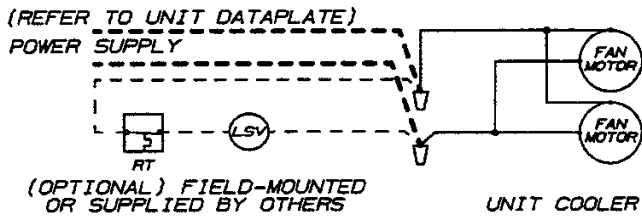

Diagram 8. Typical Wiring Diagram for Single Evaporator with and without Defrost Timer.

Air Defrost with Defrost Timer



Air Defrost without Defrost Timer



- LEGEND:
- 1. TM-----TIMER MOTOR
 - 2. LSV-----LIQUID SOLENOID VALVE
 - 3. PDS-----PUMP DOWN SWITCH
 - 4. RT-----ROOM THERMOSTAT
 - 5. WN-----WIRE NUT
 - 6. -----FACTORY WIRING
 - 7. - - - - -FIELD WIRING

PART NO. 29613714

Notes

Service Record

A permanent data sheet should be prepared on each installing contractor's files. If another firm is to handle service and installation, with a copy for the owner and the original for the maintenance, additional copies should be prepared as necessary.

System Reference Data

The following information should be filled out and signed by Refrigeration Installation Contractor.

Date System Installed: _____
 Installer and Address: _____

Condensing Unit

Unit Model#: _____
 Unit Serial #: _____

Compressor Model #: _____ Compressor Model #: _____
 Compressor Serial #: _____ Compressor Serial #: _____

Electrical _____ Volts _____ Phase _____
 Voltage at Compressor L1 _____ L2 _____ L3 _____
 Amperage at Compressor L1 _____ L2 _____ L3 _____

Evaporator(s)

Quantity _____

Evaporator Model #: _____ Evaporator Model #: _____
 Evaporator Serial #: _____ Evaporator Serial #: _____
 Electrical _____ Volts _____ Phase _____

Expansion Valve Manufacturer/Model _____

Ambient at Start-Up _____ °F

Design Box Temperature _____ °F _____ °F

Operating Box Temperature _____ °F _____ °F

Thermostat Setting _____ °F _____ °F

Defrost Setting _____ / day _____ minutes fail-safe _____ / day _____ minutes fail-safe

Compressor Discharge Pressure _____ °F _____ °F

Compressor Suction Pressure _____ °F _____ °F

Suction Line Temperature @ Comp. _____ °F _____ °F

Discharge Line Temperature @ Comp. _____ °F _____ °F

Superheat at Compressor _____ °F _____ °F

Suction Line Temperature @ Evaporator _____ °F _____ °F

Superheat at Evaporator _____ °F _____ °F

Evacuation: # times _____ Final Micron _____ # Times _____ Final Micron _____

Evaporator Drain Line Trapped Outside of Box: yes no

Since product improvement is a continuing effort at Heatcraft, we reserve the right to make changes in specifications without notice.

HEATCRAFT®

Refrigeration Products

2175 West Park Place Blvd. • Stone Mountain, GA 30087 • (770) 939-4450 • FAX: (770) 908-5480